

A SUSTAINABLE ENERGY MANAGEMENT FOR HYBRID PHOTOVOLTAIC/WIND/GRID POWER GENERATION SYSTEM

R.SELVAM

Assistant Professor, Department of Electrical and Electronics Engineering, Shreenivasa Engineering College, Dharmapuri, Tamilnadu ,India, Anna University, +91-8098978052, selvamr37@gmail.com

Dr.R.VELAVAN

Professor, Department of Mechanical Engineering, PSG College of Technology, Coimbatore,Tamilnadu, India, Anna University,+91-9443059745, velavan.r@gmail.com

Dr.R.SOUNDARRAJAN

Associate Professor, Department of Electrical and Electronics Engineering, PSG College of Technology Coimbatore,Tamilnadu, India, Anna University, +91-9942069911,asr.psg@gmail.com

Abstract: *Recently, renewable energy sources became more attractive, due to increasing energy needs and factors like limited reserves, increasing energy costs and environmental pollution. As these sources don't cause any environmental pollution and have an unlimited supply, it is extensively utilized day by day. Solar and wind are the two renewable sources considered in this paper. In renewable energy system, a smart power management system is essential to maintain sustainability of this energy. Since solar and wind are the renewable sources which required a better power management system, thereby they fulfill the raising power demand, but their reliability in terms of power quality and sustainability are doubtful. In the renewable energy system, the generated power is collected on a common DC bus which is used for supplying to load. This DC power bus is operated in an extensive manner that, there is a base power available for permanent loads for ever. Then, depending upon the availability of those power sources, the extra power demand is provided from either PV or wind source. The whole system is operated by a smart management system with the help of the fuzzy logic method. The fuzzy based smart management system which determines the amount of power to be supplied based on the power information from a solar / wind system. The smart power management system will measure and track the availability of the maximum generated power from wind system that increases the installed unit's efficiency. The result obtained will prove in an effective manner power management system.*

Key words: Wind System, PV system, Power management system, MPPT, Sustainability.

1. Introduction

As the fossil fuel reserves get closer to depletion, renewable energy sources gain momentum as an important part of power generation system. Of all the renewable energy sources, solar and wind energy sources are the most promising power generation system, as they are freely available, omnipresent, omnipotent and environmental friendly [1-3]. Many advantages are there in using PV solar panels and wind turbine together [4,

5]. The main objective is to attain maximum power in varying environmental condition. Similar to PV solar panels and wind turbine, several studies were there related to power flow and energy management in electrical power systems [6-8]. Energy sources such as wind turbines, solar panels, diesel generator and fuel cell can be used both as hybrid or stand alone. Various hybrid power generations were implemented such as wind/fuel, wind/PV, PV/wind/fuel cell, PV/grid and PV/wind/battery [9]-[12], [23]. These studies tend to increase energy sustainability, power quality and stabilize the frequency and amplitude of the voltage on a definite value on load side.

Apart from energy management a very important part of the studies associated with renewable energy utilization schemes also, [13]. In renewable energy systems, energy management deals with each source and user side control problems to keep the operation of the overall system efficiently [14, 15], [24-26]. Maximum Power Point Tracking (MPPT) is an important part of the work, because the smart power management system calculates the maximum power of a wind energy conversion system. There are numerous strategies which produce MPPT to obtain maximum power from renewable energy systems. An MPPT implemented in renewable system is defined with more effective controls of converters to run the system continuously. Overall the wind system will work with maximum efficiency [16-22]. This study suggests that, there is a MPPT designed in a different way, which constantly and accurately calculates the maximum power from wind turbines. Thus MPPT is an important part of the smart power management system.

Smart power management system is different from other methods which is much simpler and cheaper. In this method, loads are fed by a power management

system from the hybrid system consist of wind energy system, PV panels and grid. Wind energy system consists of a new method to a common DC bus which is considered too called MPPT method. The hybrid system is connected, to have power sustainability. When additional power is needed, the backup battery unit which is connected to PV system is charged for emergency usage. This system, in addition to the source side, load side management system is also more important, so as to considered in this method. Further, energy management system will continuously and quickly respond without being bounded to environmental conditions, which keeps some quantity of power, in reserve and during instantaneous load shed dings and the proposed system efficiently control the system. The proposed smart power management system is cheaper, simpler and it is clearly an efficient approach.

2. Proposed power management system

The sustainable smart power management system consists of wind and PV power generating units with a utility grid as hybrid sources as shown in Fig.1. Over the desired converters, these three generating units are connected to a DC power pool. A backup battery cluster is additionally connected to Photovoltaic system, in order to store the extra power generated by solar system, when the power generated from the Photovoltaic system is not delivered to the load. In the system AC load types are considered, which is connected to the AC power bus that is fed from the common DC power pool. The collected data from load side and source side is transferred to the PC and it is to be estimated for decision making procedure of the power management system.

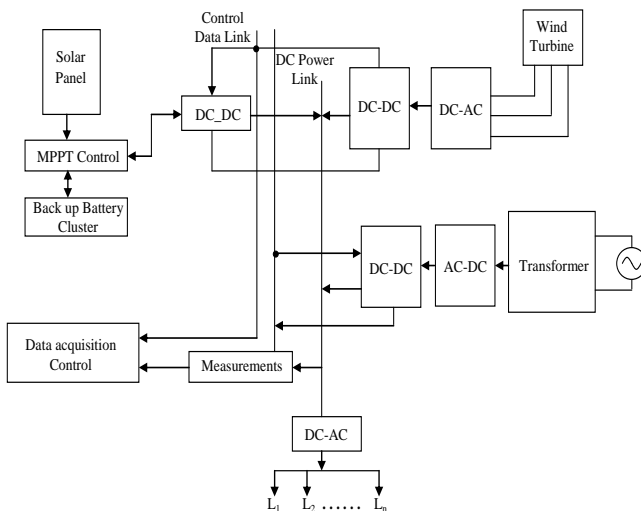

Fig.1.Smart power management system

The management of power algorithm is developed to operate both in wind energy system and photovoltaic energy system with utmost. The maximum power can generate under varied environmental conditions that maintains the load side power supply demand at required amount. Thus the power management includes MPPT of wind energy system, photovoltaic energy system, utility connection energy storage and load switching. Besides, the quality of power problems like voltage sags, harmonic elimination, frequency deviations, voltage magnitude and voltage increments are included within the proposed management system. For the multi-objective and multi input system we developed a simple fuzzy logic based decision making algorithms.

2.1. Wind Energy System

The mechanical energy which is produced by the wind is converted into electrical energy by the wind turbines from potential to kinetic. The wind turbine model is developed to assess the power characteristics in principle by the steadiness of the turbine. By coupling 2 squirrel cage asynchronous machines together the emulator of wind energy system is set up. The power of the prime mover is selected as 5KW and the generator is 3KW. Therefore the generator can also be performed, yielding at overpower conditions to extend the analysis of the operating cases. The prime mover which is placed on the left side of machine represents the wind turbine and it is regulated with a voltage/frequency speed controller. The generator output voltage changes between 320V and 400V according to the wind speed. By using a step down transformer, a 3 phase voltage magnitudes acquired, from the generator is reduced to a lower level. So, the transformer output voltage changes up to 38V and the output of full bridge rectifier changes up to 50V. The variable voltage is converted to a constant voltage with a help of DC chopper, which is to be connected to a DC bus.

The reactive power to generate energy at this point is supplied, rectified and the three-phase voltage is sent across a chopper and it is brought to 48V and coupled to a common DC bus. Another inverter is used to convert this 48V to 230V AC. The voltage and current information on the copper input voltage, the loads and output current is calculated and transferred to the system.

2.2. Photovoltaic System

The PV cell and the PVES are modeled in such a way to assess their characteristic features. The PV cell

voltage-current equation is based upon photocurrent of a P-N junction. The photocurrent is a function of changes with the sunlight and solar irradiation. The function of photocurrent the P-N device connection terminal voltage varies at the point.

The external current maximum value is the short circuit current and it is assumed to be equal to the photocurrent generated. It is noticed that the cell gets heated which results in decreased terminal voltage, as the cell current increased. In commercial application the PV panels are joined together in parallel and serial combinations and fabricated such as PV modules, to be used efficiently. The PV module current is decided by a number of series branches and PV module voltage is decided by series connected PV cells. To acquire the needed load power, the PV modules are connected in series and the PV arrays are yielded in parallel.

2.3. Grid Connection

Two types of operating conditions are used in the proposed renewable energy scheme. The first condition depicted is the one which source power to the individual loads in which the grid utility is not connected or not available. Therefore power produced from each power generation unit is collected in the direct current bus. The utility voltage is converted to DC constant value, which is to be connected to a common DC bus like PV and wind system, as shown in Fig. 4. The composed data from the system is moves to the computer which is utilized for decision making and control process.

2.4. Sustainability

Thus the renewable sources such as solar and wind power is used to generate the electrical power. These renewable sources are affected by environmental conditions resulting in load problems. The amount of power generated by solar energy changes, when the weather is cloudy or without sunlight. Consequently, all the time the wind does not blow at the same speed and it's not continuous. So, the amount of energy to be generated by these kinds of sources are not constant.

In low powered applications, for example, while supplying energy to a house, power failure will create a very embarrassing situation. To ward of such problems the power sources should be operated efficiently. To avoid problems such as discontinuities and voltage sags, which occur resulting, from sudden load changes or weather changes, this decision making process and proposed method is developed.

The total power generated from the wind is used as the primary supply source which in turn augment to the supply power to base load. As long as there is adequate wind power, extra power generated is stored and the secondary power system is kept off. In the secondary power system, which is a solar or utility grid is triggered, when the wind power is less than the needed load power.

2.5 Smart power management design

The power transfer to load from the renewable sources should be controlled in an appropriate way, to solve the power quality and sustainability. For this reason a proposed power management system has been intended to stop, under and over voltage operations and power discontinuity so that the loads operate appropriately. In an effective way the power management system is automated, by switching ON/OFF the sources and backup units. There is no need for secondary sources like backup batteries and PV, if the wind power is adequate enough to supply the load. If there is a decreased wind power, the gap is occupied by PV first, followed by batteries, and then the utility. The excess power generated is reserved and utilized only when required. Fig.2. shows the overall energy generation system.

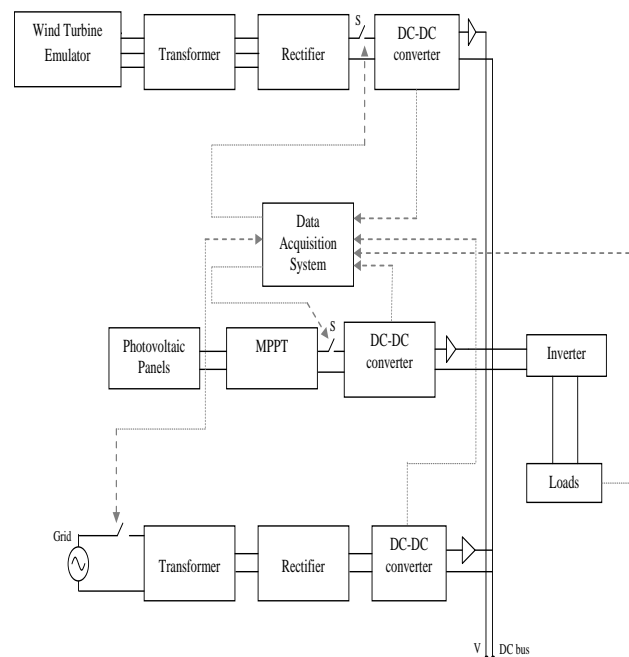

Fig.2. Overall system of the proposed Energy management System.

The electrical power is generated by PV solar panels and wind generator in this system. The utility is kept as an additional source which can be used when required. The power generated from the PV system is utilized to feed

power to the load when there is inadequate wind power, and to charge the batteries when sun and wind is sufficient. It is to be analyzed that the collected data from the various parts of the overall system is transferred to the computer.

In power systems, the key objective of implementing a power management algorithm is to have the power ready to be utilized and feed load constantly. Therefore, it is necessary to calculate the peak power value of PV solar panels and Wind energy system. The MPPT device which is used for solar panels manages on its own accord. Thus, the peak power calculation in PV solar panels is done. Nevertheless, the value of peak power should be defined from wind system. In this system, the wind is the primary supply. At the same time, the amount of energy to be produced is affected by the changing environmental conditions. So, the power management system, leaving the base power in the system to ignore this effect and a base power should be provided without any interruption for the loads. In the proposed system, the base power is defined is that; it is able to change easily inside the software whenever it is required. If environmental conditions are good enough, this means that if there is adequate wind and sun, the PV solar panel generation system and wind energy generation system will yield the maximum power. The main principle of the operational system is under.

- (a) At first the system starts equipped with both wind and solar energy
- (b) According to load condition the PV solar panel system or wind system will be kept working, after the transients are over and measurements are done. If there is an unsuitable environmental condition for Wind system or PV solar panels to operate one by one, they will operate together. The grid will operate when the power is not up to the load energy requirements.
- (c) The Wind system will operate if it is able to handle the load power requirement and only to charge the batteries of PV solar panels that are in use.
- (d) Suppose the Wind system could not generate adequate power, both PV solar panels and Wind system will operate together. The grid will engage if both are inadequate.
- (e) Solar panels will supply the load, when there is no wind.
- (f) The grid will start to operate, if there is no sun and the batteries are empty or the battery cannot supply the loads with its real amount of power.

2.6. Fuzzy Logic

Fuzzy logic algorithms are normally used in fuzzy

decision makers that discover applications in systems which need a conclusion from indefinite input data. The power produced by the wind energy system becomes indefinite including the maximum generated power, this is because the wind conditions are not easily predictable and are not definite. So a fuzzy reasoning algorithm is developed to decide the maximum power produced by Wind system. A fuzzy decision maker generally estimate them in the rule base system and obtains an input that is established earlier, representing the input and output relations of the indefinite system in terms of fuzzy rules and fuzzy membership functions. The fuzzy rule is the estimation of the rules to produce fuzzy conclusions from its interactions. Therefore, to utilize by the controller, these values can be included in a value range and then it can be expressed. Additionally, it becomes a group member which has clear boundaries and they are fuzzified to fuzzy values. Correspondingly, by the process called defuzzification, the fuzzy outputs concluded and converted to crisp values, if the output is needed as crisp value.

To decide the value of power demand, which is supplied from the wind/PV sources, the online data collected and transferred to computer is used. Fuzzy decision maker uses the Wind system quantities to determine the maximum generated power by wind system. In power management system, the maximum power values of both PV panels and wind system are used. In the system are could easily notice the current and voltage values are varying. It is noticed that the wind speed lower limit is to be equal to voltage lower limit. The needed energy conversion is not adequate, which is below the voltage lower limit. Fuzzy decision making output is the output power space which estimates the maximum power value supplied by the wind energy system. The power produced by the Wind system varies as its functions. Thus relying on the wind speed levels, the maximum power was gained from the wind system changes, and should be decided for distinct speed levels.

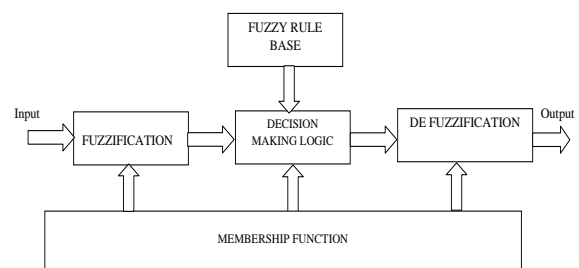

Fig.3.Fuzzy Decision Maker

- Fuzzy reasoning algorithm is utilized to attain the maximum wind generation power under varying environmental condition.
- The voltage and current from wind system are the inputs to the fuzzy decision maker. The calculation of maximum power is determined by voltage and current. The power produced is directly proportionate to the wind speed. As a result if wind speed changes its corresponding voltage and current also changes.
- The voltage and current are converted into fuzzy values in which triangular membership function is used.

4. Results

This system comprises of solar panels and wind energy without any control system; it has no control mechanism or management system, which completely operates in open mode. The system is analyzed, when PV panels and wind are on without any control management system.

It is to be noted that when a load power is on, both PV and wind system cannot supply the loads at certain duration, so the system cannot operate appropriately. The result of this state 1 is shown in Fig.4&5. Discontinuation of the power occurs even after the system has generated enough power. This can be eliminated by utilizing both solar and wind applying appropriate power management system. The power discontinuity can be avoided on loads by introducing decision making system. The proposed energy management system can achieve this control system in an efficient manner.

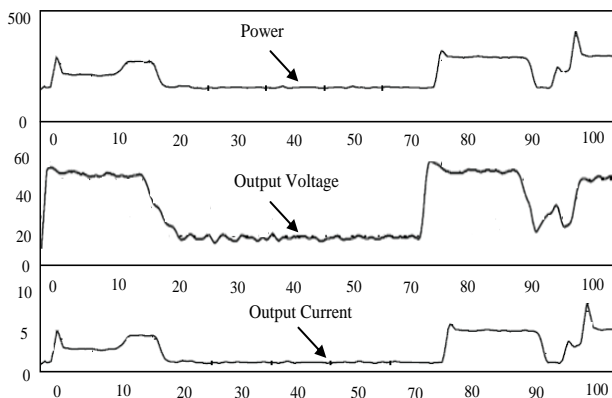

Fig.4. Output Voltage, Output Current & power variations of

wind system in state 1.

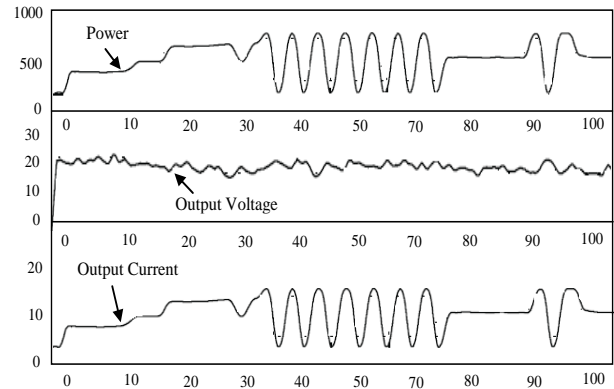

Fig.5. Output Voltage, Output Current & power variations of solar system in state 2.

The voltage, current and power changes of wind energy system is shown in Fig.6, in which power of the load is changed randomly in varying time period which results in changes of quantities of wind energy system. It is due to power extraction of wind speed, the wind energy system is always active, and the amount of power transferred to the system changes obviously. PV system voltage, current and power changes in state 2 is shown in Fig. 7.

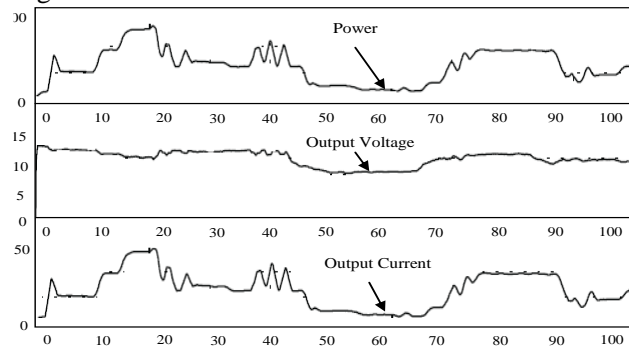

Fig.6. Output Voltage, Output Current & power of wind system in state 2.

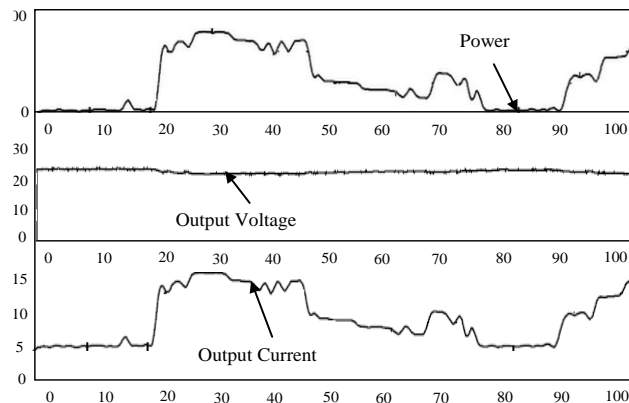

Fig.7. Output Voltage, Output Current & variations power variations of solar system in state 2.

Depending upon the sudden changes, both wind and PV system operate for short period. The load voltage changes. Since data is taken from voltage detector, distortions are observed. Hence by adding inductive load and resistive load to the system, the system behavior under different load conditions was observed. Fig.8. shows the value changes in voltage, current and power in wind system. Due to high wind speed reduction, the generated voltage magnitude is very low in certain levels. Fig.9. shows the PV system time variations of current, voltage and power. Since wind system is not adequate, PV system is inactive to generate essential load power. A current, voltage and power variations of the utility grid is shown in Fig.10. The utility grid supplies power for a period, when both PV and wind system were switched off condition, and they do not generate adequate power. The changes in voltage, current and power on the load is shown in Fig.11. According to the load conditions, the load current varies and the load voltage is set aside as 220V. When there is a higher wind speed, power generated by wind system is high and it is lower when there is low wind speed correspondingly.

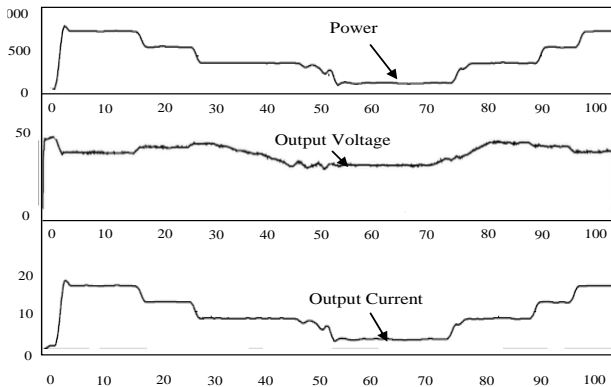

Fig.8. Voltage, Current & power variations of wind system.

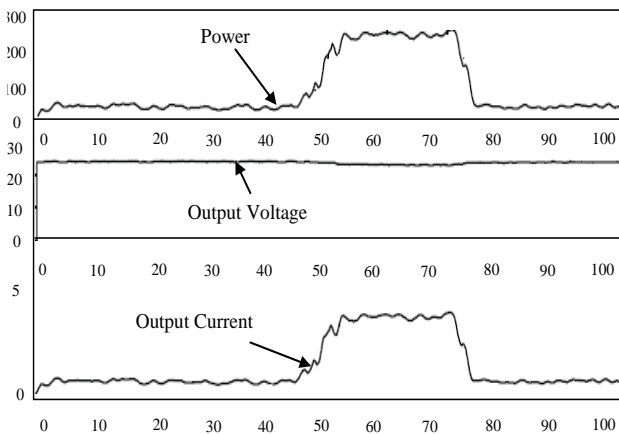

Fig.9. Voltage, Current & power variations

of solar system

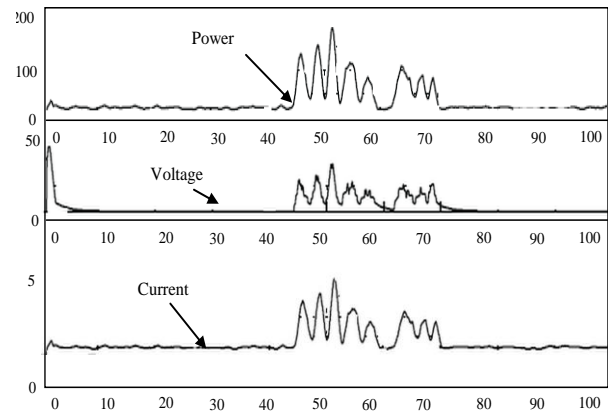

Fig.10. Output Voltage, Output Current & power variations of grid system.

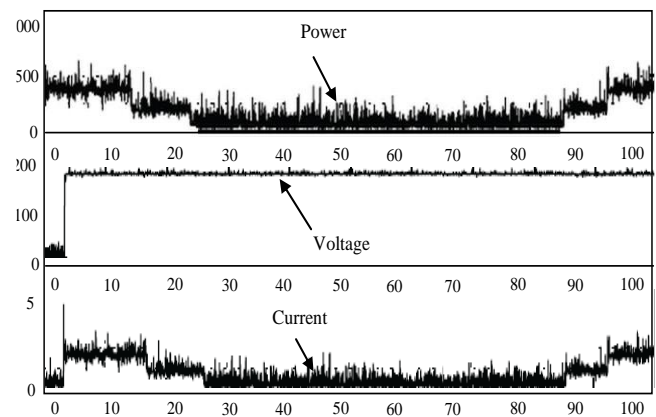

Fig.11. Output Voltage, Output Current & power variation on the load.

The power variations from PV, wind and load are shown in Fig.12. as an example without any control system. The load tries to source the power from PV panels and backup system, since power management system was not implemented, has inadequate power to feed the load. As a result, load cannot operate properly without adequate power. Fig.13. shows the power variations from PV panel, Wind system and utility grid with power of the load and maximum available wind power value. To overcome this, proposed power management system has been introduced, which supply the sufficient and adequate load power. If the environment or load condition changes, power to the load is supplied from the sources to prioritize the use of PV, wind and grid. If the wind power is sufficient enough for the load, the PV power generated is stored in batteries. The PV panel comes into act when there is an insufficient power to drive the load. Hence the utility grid is utilized when both PV and wind system do not

generate required power.

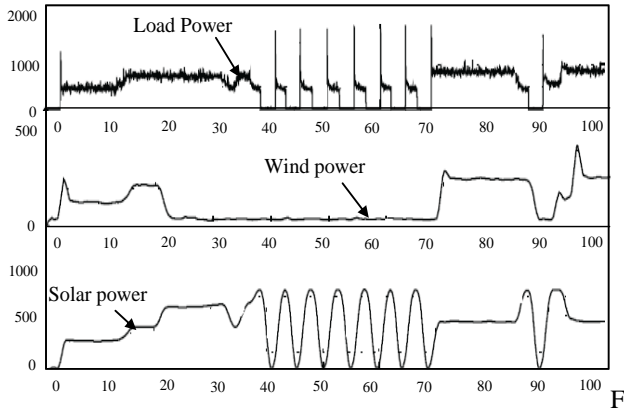

Fig.12. Power variations without any management system

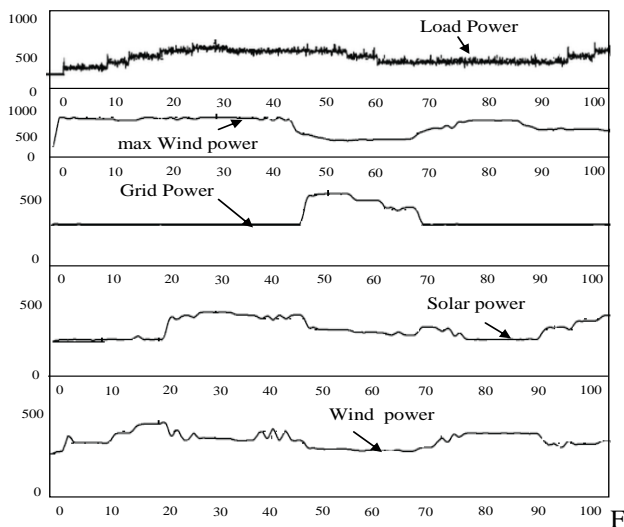

Fig.13. Power variations under proposed smart power management system

5. Conclusion

In this paper, focused on photovoltaic and wind production of electrical energy optimization. A smart power management system is introduced in the renewable energy system with its energy sustainability. The smart power management system is evaluated with the help of renewable system comprising of PV panels and wind system. Hence the system of management is essential for its sustainability of PV and wind systems which are not reliable on the load side. In this system, the power from PV, Wind and utility grid are collected at common DC bus and loads are fed without any interruption. The effects of renewable energy changes are handled by the smart power management by operating PV, Wind and utility grid consequently. And also it is utilized to measure and track the available and generated maximum power from wind system, which increases the installed unit's efficiency. The required and generated power information from PV and solar system

were utilized to control the overall system with the help of fuzzy logic reasoning. The proposed smart power management method will provide a feasible solution to meet out the power demand and considered as a smart operator in renewable energy applications.

References

- [1] F. Blaabjerg, K. Ma and Y. Yang, "Power electronics - The key technology for Renewable Energy Systems," *Ecological Vehicles and Renewable Energies (EVER)*, 2014 Ninth International Conference on, Monte-Carlo, 2014, pp. 1-11
- [2] V. Quasching, *Understanding Renewable Energy Systems*, Earthscan, London, UK, 2005.
- [3] M. J. Laly, E. P. Cheriyan and A. T. Mathew, "Soft computing optimization based optimal operation of powergrid with renewable energy sources and storage systems," 2016 IEEE International Conference on Industrial Technology (ICIT), Taipei, 2016, pp. 564-569.
- [4] Rojas, Juan M. Lujano, Rodolfo Dufo-López, and José L. Bernal-Agustín. "Optimal design of PV/Wind/Battery systems by genetic algorithms considering the effect of charge regulation." *Advances in Mechanical and Electronic Engineering*. Springer Berlin Heidelberg, 2012. 241-247.
- [5] Camacho, Eduardo F., et al. "Control for renewable energy and smart grids." *The Impact of Control Technology*, Control Systems Society (2011): 69-88.
- [6] K. Rahbar, J. Xu and R. Zhang, "Real-Time Energy Storage Management for Renewable Integration in Microgrid: An Off-Line Optimization Approach," in *IEEE Transactions on Smart Grid*, vol. 6, no. 1, pp. 124-134, Jan. 2015.
- [7] Jeong, Gwi-Seong, Won-Yong Lee, and Chang-Su Kim. "Energy management strategies of a fuel cell/battery hybrid system using fuzzy logics." *Transactions of the Korean hydrogen and new energy society* 15.1 (2004): 12-22.
- [8] Bocklisch, Thilo. "Hybrid energy storage systems for renewable energy applications." *Energy Procedia* 73 (2015): 103-111.
- [9] Nayeripour, M., Hoseintabar, M., Niknam, T., & Adabi, J. (2012). Power management, dynamic modeling and control of wind/FC/battery-bank based hybrid power generation system for stand-alone application. *European Transactions on Electrical Power*, 22(3), 271-293.

- [10] Lagorse, J., Simoes, M. G., Miraoui, A., & Costerg, P. (2008). Energy cost analysis of a solar-hydrogen hybrid energy system for stand-alone applications. *International journal of hydrogen energy*, 33(12), 2871-2879.
- [11] Elbaset, A.A., 2011. Design, modeling and control strategy of PV/FC hybrid power system. *J. Electrical Systems*.
- [12] Qiang, M., Wei-yang, W., & Zhen-lin, X. (2006, August). A multi-directional power converter for a hybrid renewable energy distributed generation system with battery storage. In *Power Electronics and Motion Control Conference, 2006. IPEMC 2006. CES/IEEE 5th International (Vol. 3, pp. 1-5)*. IEEE.
- [13] G. Li, Y. Chen and T. Li, "The realization of control subsystem in the energy management of wind/solar hybrid power system," *Power Electronics Systems and Applications, 2009. PESA 2009. 3rd International Conference on, Hong Kong, 2009*, pp. 1-4.
- [14] Petković D, Shamshirband S, Anuar NB, Saboohi H, Wahab AW, Protić M, Zalnezhad E, Mirhashemi SM. An appraisal of wind speed distribution prediction by soft computing methodologies: a comparative study. *Energy conversion and Management*. 2014 Aug 31;84:133-9.
- [15] Olatomiwa, L., Mekhilef, S., Ismail, M. S., & Moghavvemi, M. (2016). Energy management strategies in hybrid renewable energy systems: A review. *Renewable and Sustainable Energy Reviews*, 62, 821-835.
- [16] Munteanu, I., Bratcu, A. I., & Ceangă, E. (2009). Wind turbulence used as searching signal for MPPT in variable-speed wind energy conversion systems. *Renewable Energy*, 34(1), 322-327.
- [17] Galdi, V., Piccolo, A. and Siano, P., 2008. Designing an adaptive fuzzy controller for maximum wind energy extraction. *Energy Conversion, IEEE Transactions on*, 23(2), pp.559-569.
- [18] Abo-Khalil, A. G., & Lee, D. C. (2008). Maximum Power Point Tracking Based on Sensorless Wind Speed Using Support Vector Regression. *IEEE Transactions on Industrial Electronics*, 55(3).
- [19] Ni, L., Patterson, D. J., & Hudgins, J. L. (2009, June). Maximum power extraction from a small wind turbine using 4-phase interleaved boost converter. In *Power Electronics and Machines in Wind Applications, 2009. PEMWA 2009. IEEE (pp. 1-5)*. IEEE.
- [20] Calderaro, V., Galdi, V., Piccolo, A., & Siano, P. (2008). A fuzzy controller for maximum energy extraction from variable speed wind power generation systems. *Electric Power Systems Research*, 78(6), 1109-1118.
- [21] Zhu, Y., Cheng, M., Hua, W., & Wang, W. (2012). A novel maximum power point tracking control for permanent magnet direct drive wind energy conversion systems. *Energies*, 5(5), 1398-1412.
- [22] Agarwal, V., Aggarwal, R. K., Patidar, P., & Patki, C. (2010). A novel scheme for rapid tracking of maximum power point in wind energy generation systems. *Energy Conversion, IEEE Transactions on*, 25(1), 228-236.
- [23] S. Surender Reddy (2017) Optimization of Renewable Energy Resources in Hybrid Energy Systems. *Journal of Green Engineering*, Vol. 7, 43–60.
- [24] Mohammad Sarvi and Isa Nasiri Avanaki, "An optimized Fuzzy Logic Controller by Water Cycle Algorithm for power management of Stand-alone Hybrid Green Power generation", *Energy Conversion and Management, Elsevier*, Vol. 106, pp.: 118–126, 2015.
- [25] Onur Ozdal Mengi and Ismail Hakki Atlas, "A new energy management technique for PV/Wind/Grid Renewable Energy system", *International journal of Photo energy* 2015.
- [26] Ismail H. Atlas, "Energy management and fuzzy decision-making", *Institution of Engineering and Technology*, 2017.