

DSP BASED IMPLEMENTATION OF HIGH PERFORMANCE CONTROL FOR INDUCTION MOTOR DRIVE

Vivek V. PURANIK

SVPM's College of Engineering, Malegaon (Bk), Baramati, Maharashtra 413115., India
+917798324545, Email: vivekpuranik9@gmail.com

Vijay N. GOHOKAR

Marathwada Mitra Mandal's College of Engineering, Pune, Maharashtra-411052, India.
+919422884443, Email: vngohokar@rediffmail.com

Abstract: *Amongst many control techniques developed and used for induction motor drives, Flux or Field oriented control is probably the most popular control method used for high-performance induction motor applications. The field oriented control algorithm involves heavy mathematical computations and therefore its implementation requires a high execution speed processor/controller to meet all practical system demands. However, the inherent computational power of the Digital Signal Processors (DSP) permits very fast computations. It provides user an easy way to implement various control techniques of induction motor drives for real time simulink model.*

In this paper, a simulation model of a current controlled, voltage source inverter fed, rotor flux based indirect field oriented drive system for an induction motor is developed in MATLAB environment with simulink and its performance is tested by implementing it on a tailor made experimental setup of 1 HP induction motor and DSP controller board-DS1202. The test results of the induction motor drive are studied for various operating conditions.

Key words: *Digital Signal Processor, dSPACE DS 1202, Field Oriented Control, Induction Motor Drive, Matlab/Simulink.*

1. Introduction

High performance control of a.c. induction motors depends on the principle of Flux Oriented Control (FOC). In flux oriented control, a rotating reference frame has to be aligned either to the stator, air gap or rotor flux vector. When the control is performed in a reference frame aligned to the rotor flux space vector, it is called as Rotor flux orientation control [1-3]. Field oriented controllers mainly aim to maintain the flux producing, i.e. the direct component of the stator current space vector in phase with the rotor flux space vector under all operating conditions. The quadrature axis current component, which then lies in quadrature with the rotor flux vector, directly controls the torque developed by the machine. When correctly implemented, field oriented control permits the independent control of the torque and flux of the a.c. machines, in a manner identical to that of the

separately excited d.c. motor. Most often there is no direct measurement of either the produced torque or flux, so the control is implemented by a closed loop current control structure known as the Indirect Rotor Field Oriented Control. [4-5].

A significant amount of work has been done on simulation of induction motor drive using digital signal processor dSPACE DS1103, dSPACE DS1104 and dSPACE 1105 controller boards. However, the detailed design and development methodology of real time implementation for control of induction motor drive using dSPACE DS 1202 is not available to the author's knowledge in the existing literatures as the real challenge of hardware implementation lies in selecting appropriate hardware equipment and perfect configuration of the equipment with controller board.

Hence the objective of this paper is neither to review the field oriented control technique nor to make any improvements in it.

But the aim of the research presented in this paper is to help graduates, post graduates and budding researchers in understanding the real time implementation of induction motor drive control using dSPACE's MicroLab Box DS1202 controller board. DS1202 base board can compute models up to 6 times faster than the DS1103 or DS1105, making it fastest processor yet [6]. It uses the latest FPGA technology to provide fast and efficient testing.

The main contribution of this paper is the realization of a non real-time indirect rotor flux oriented induction motor model in Matlab/Simulink and investigation of its validity for real-time applications using dSPACE DS1202 controller board.

2. Proposed Control Technique

Field oriented control works on the principle of decoupling the stator current components used for producing the flux and torque. Fig. 1 shows the

phasor diagram that explains the FOC scheme. The field oriented control suggests transforming the coordinates from the fixed reference stator frame to the rotating synchronous frame. This transformation makes possible the decoupling of the stator current into two components, which are responsible for the flux and the torque generation. Thus the decoupling allows the induction motor to be controlled as a separately excited DC motor. Figure 1 shows the phasor diagram that explains the FOC scheme.

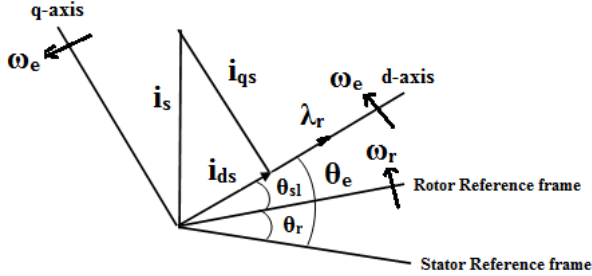

Fig. 1. Phasor diagram of FOC scheme

The basic procedure to implement a Field control algorithm is that the measured three-phase currents are converted into a complex space vector by Clarke Transformation. This conversion provides the variables i_α and i_β from the measured i_a , i_b and i_c values. The rotor flux is then calculated by estimation. The controller generates the slip speed ω_{sl} signal that is added with electrical speed to give synchronous speed ω_s . It is then integrated that yields the rotor flux orientation, θ_e . The space vector is then transformed from the $\alpha\beta$ -system to the dq -system by a Park Transformation. A reference flux is used to compute the i_{ds}^* . A PI controller is used to generate the reference torque, T_e^* . i_{qs}^* is generated using the reference torque value and the estimated flux reference torque value and the estimated flux value. i_{ds}^* and i_{qs}^* are converted back to a set of three phase currents to produce i_a^* , i_b^* and i_c^* using inverse Park and Clarke transformation. These currents are then compared with i_a , i_b and i_c using hysteresis comparator that generate inverter gate signals.

From the Fig. 1, following relationships can be established [7]-[8]

$$\lambda_{qr} = 0; \Rightarrow \frac{d\lambda_{qr}}{dt} = 0 \quad (1)$$

$$\lambda_{dr} = \lambda_r \quad (2)$$

Hence the flux equation becomes-

$$\lambda_r = \frac{L_m}{1 + \tau_r s} i_{ds} \quad (3)$$

Where $\tau_r = L_r/R_r$, is a rotor time constant.

Torque can be expressed as-

$$T_e = \frac{3}{2} \frac{P}{2} \frac{L_m}{L_r} (i_{qs} \lambda_{dr} - i_{ds} \lambda_{qr}) \quad (4)$$

By substituting from equation (1) and (2), equation (4) reduces to-

$$T_e = \frac{3}{2} \frac{P}{2} \frac{L_m}{L_r} (i_{qs} \lambda_{dr}) \quad (5)$$

This can also be expressed as-

$$T_e = K_T i_{qs} \quad (6)$$

This shows that the torque can be controlled only by q-axis component of the stator current. The quadrature-axis reference current (i_{qs}^*) can be computed from reference torque T_e^* using the following equation-

$$i_{qs}^* = \frac{2}{3} \frac{2}{P} \frac{L_r}{L_m} \frac{T_e^*}{\lambda_r - est} \quad (7)$$

Rotor flux angle, θ_e , necessary for coordinate transformation, is obtained from the calculation of the speed of rotation of the rotor speed ω_m and slip ω_{sl} , as follows-

$$\theta_e = \int (\omega_m + \omega_{sl}) dt \quad (8)$$

The slip frequency is obtained as –

$$\omega_{sl} = \frac{L_m}{\lambda_r} \frac{R_r}{L_r} i_{qs}^* \quad (9)$$

Figure.2 shows the block diagram of the indirect rotor flux oriented control algorithm.

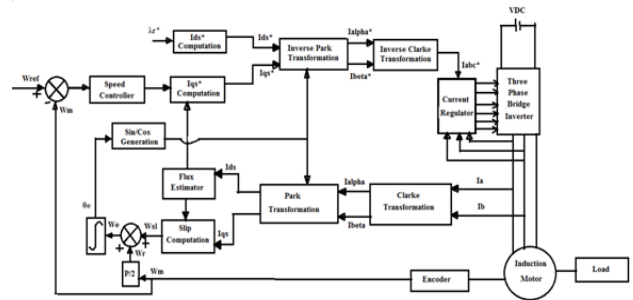

Fig. 2. Block diagram of Indirect Rotor Field Oriented Control Algorithm.

3. Realization of Proposed Control Technique

Based on equations in section 2 and using various tool boxes available in the SIMULINK library, indirect rotor field oriented control algorithm is realized in Matlab/Simulink [9]-[12] as shown in Fig. 3.

4. System Description

The proposed control algorithm for the control of IM drive is digitally implemented using dSPACE DS-1202 through both hardware and software [13]-[18].

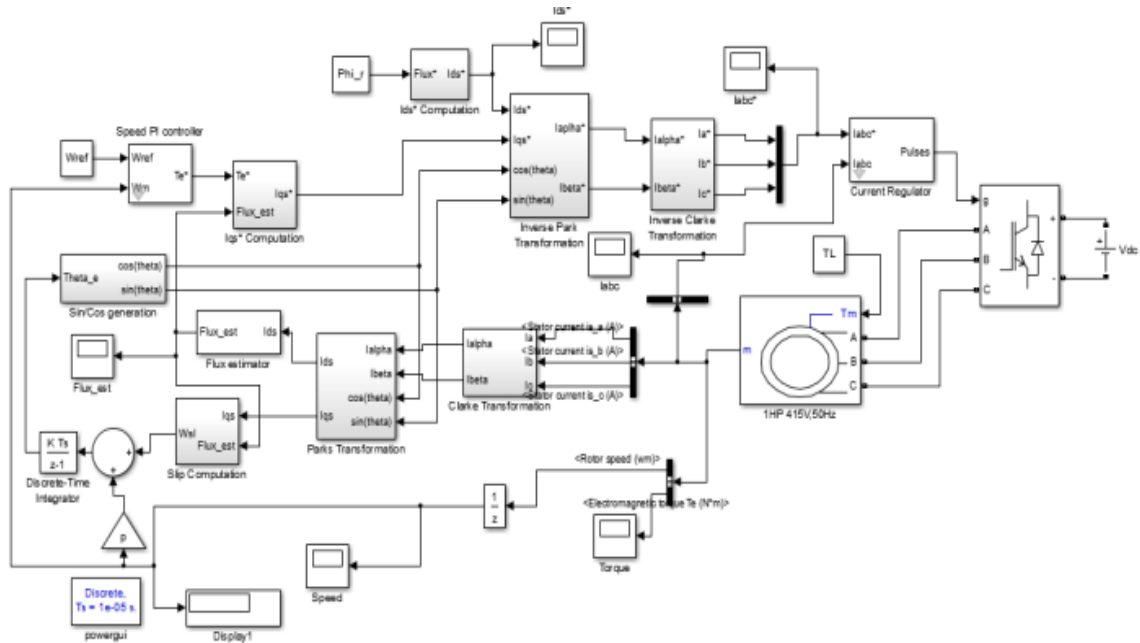

Fig.3. Realization of Indirect Rotor Field Oriented Control algorithm using Matlab/Simulink

The hardware configuration for this work is depicted in Figure 4. It consists of hardware components as an induction motor, a bridge rectifier, a three phase inverter, a speed sensor, current sensor, DC Voltage sensor, FPGA Board, DSP DS1202 controller board, a load arrangement and DC regulated power supplies for isolation circuit, driver circuit etc. while the software components are MATLAB, Real Time Interface (RTI) and Control Desk software.

The inverter used is made up of 6 IGBT's having ratings of 15 A, 1200V. Each IGBT in the upper and lower arm has a driver IC's as TLP-250. A gate driver circuit provides a gate voltage and current to IGBTs by amplifying these signals to required level for switching the IGBTs. A DC voltage applied to this 3-phase bridge Inverter is achieved through a standard 1-phase uncontrolled bridge rectifier having a rating of 1000V, 15A and two capacitors with a rating of 2200 μ f, 250V each are used in series as a filter to eliminate voltage ripples in DC link.

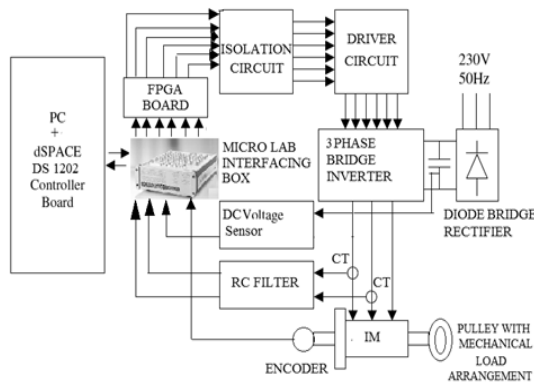

Fig.4. Hardware Configuration

The aim of the isolation circuit is to provide isolation between the Inverter and the FPGA board. The isolation is realized by using opto-coupler ICs.viz 4N35. The isolation circuit also provides isolation between the output signals from the FPGA board and the inputs to the driver circuit.

The isolation circuit receives 6 signals from the FPGA board and generates 6 output signals as H1, H2, H3, L1, L2 and L3. These signals are given to the driver circuit. The FPGA development board provides a dead time delay between the upper and lower IGBTs of the inverter. It also indicates the fault messages, which are generated by the inverter circuit using LEDs on the board. The output signals of the DSP board are entered to the FPGA board. These output signals of the DSP board are first inverted and delayed to trigger the lower and upper IGBTs of the inverter. These output signals are used to obtain H1, H2, H3, L1, L2, L3 signals which are isolated from the inverter by the isolation circuit.

The DC supply required for driver circuit, isolation circuit and speed sensor is derived from regulated voltage power supply. For this, voltage regulated IC's LM7805/7812 are used.

Table 1

Name Plate Data of Induction Motor

Quantity	Symbol	Rating
Nominal Power	P _n	750 Watts
Nominal Voltage	V _n	415 Volts
Nominal Frequency	f _n	50 Hertz
Moment of Inertia	J	0.005Kg/m ²
Frictional Coefficient	B	0.003N-m-s
Pole Pairs	p	2

The motor used in the application is a 0.75 kW, three phase, squirrel cage type, star connected

induction motor. The nameplate data of the induction motor is as shown in Table 1.

The parameters of the induction motor have been found by performing no-load and blocked rotor test and the obtained parameters of the induction motor are as listed in Table 2.

Table 2

Parameters of Induction Motor

Parameter	Symbol	Value
Stator Resistance	R_s	9.395 Ω
Rotor Resistance	R_r	10.444 Ω
Stator Leakage Inductance	L_{ls}	0.0350 H
Rotor Leakage Inductance	L_{lr}	0.0525 H
Mutual Inductance	L_m	0.5492 H

The input currents of the induction motor are measured using CT's of 10:01A with well designed low pass RC filter having good frequency response to eliminate DC offset. The outputs from current sensors i.e. Phase A and Phase B are connected to any two ADC channels of DS-1202 with proper scaling.

Incremental type Rotary Encoder having 1000 PPR is used to measure the speed of the Induction motor.

In order to measure DC voltage VDC, voltage to voltage sensor having input voltage of 0- 600V DC and output voltage of 0-10V DC is connected to any one of the ADC channels of DS-1202 with proper scaling.

12V & 5V DC power supplies required for driver circuit, Isolation circuit and for encoder are obtained using Voltage regulators IC's viz. LM7812/LM7805.

FPGA board provides a dead time delay between the upper and lower IGBTs of the inverter. It also indicates the fault messages, which are generated by the inverter circuit using LEDs on the board. The output signals of the DSP board are entered to the FPGA board. These output signals of the DSP board are first inverted and delayed to trigger the lower and upper IGBTs of the inverter. These output signals are used to obtain H1, H2, H3, L1, L2, L3 signals which are isolated from the inverter by the isolation circuit.

dSPACE is a software/hardware platform for interfacing between Simulink models and hardware devices in real-time.

The DS-1202 controller board is a platform to run a real-time simulation, just as Matlab is also a platform to run non-real-time simulations.

Simulink is an interactive environment integrated

in MATLAB which is used for the purposes of modelling, analysing and simulating the whole systems. This is usually the first step in designing systems where the user can test the model off line by analyzing the theoretical version of the model. It provides designers a graphical user interface for constructing block diagrams.

Real Time Interface (RTI) is the link between dSPACE's real-time systems and the development software, MATLAB /Simulink.

Control Desk is dSPACE's well-established experiment software which allows the designer to control and monitor the operation of the overall systems. It allows the designers to look at the variables, display their behavior and modify the simulation parameters by interacting directly with the dSPACE board. By controlling the variables through control desk, there is no need to waste time in recompiling the whole model. As the variables are changed along, the designer can observe these changes straight away on control desk. If these modifications were to be done in Simulink, repetitive compilation will be required to execute the changes that have been made to the algorithm. It is similar to a digital oscilloscope where the user can observe any changes that occur, thus, helping in designing better systems. It is used to communicate with the controller and the DSP. Thus Control Desk is a user-interface used to interface both the simulation platforms.

5. Digital Implementation

For digital implementation of the proposed control algorithm, the induction motor block in MATLAB Simulink is replaced with real motor and the rectifier-inverter block with actual power converter-inverter. Here the supply voltage to the inverter is 360 V DC, so the maximum peak line to line voltage to the motor is 360 V and the maximum peak phase voltage is nearly 210 V. The switching frequency of the inverter for this experiment is 10 KHz. The control algorithm implemented in MATLAB/Simulink is downloaded in the dSpace DS-1202 control board. The rotor flux reference, Φ_{r} , required for this experiment, is set to 0.51 Wb. A .m file in Matlab is created containing all the data related to the Induction motor. Before starting the simulation, a .m file prepared earlier is executed at the Matlab prompt so that all the values of the variables in the Simulink model will be assigned to them. Through Control desk, motor is controlled and the data is recorded. Fig. 5 shows the photograph of the actual experimental set up of the proposed

control algorithm for its digital implementation.

6. Results and Discussions

Some tests such as constant speed and torque are performed to evaluate the performance of the proposed control algorithm.

The speed-control loop of the drive is designed and experimentally implemented with the PI controller. Its gains are tuned on line at rated conditions. The responses of all the parameters are observed under different operating conditions. Some sample results are presented in the following sections-

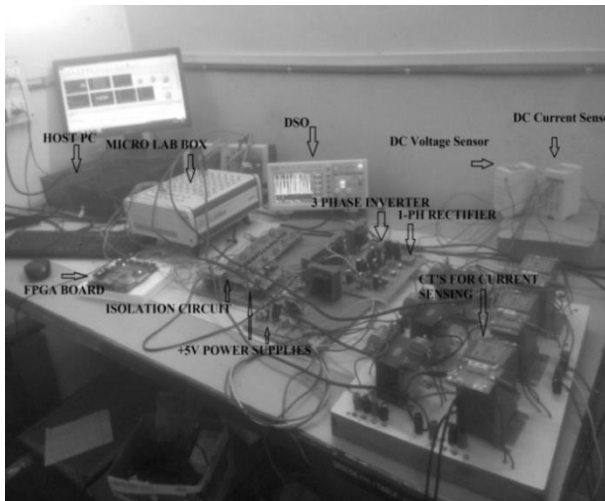

Fig.5. Experimental Set up

6.1 Experiment No.1

In this experiment the motor is run from standstill at different reference speeds with no load applied. The reference speeds considered are, 30, 50, 60 and 80, 100 and 120 rad/sec. The reference speed is given from the Control Desk. The flux reference is set to 0.51 Wb.

Fig. 6 to Fig. 9 shows the experimental responses for set speed of 50 rad/sec and its associate stator currents I_{abc} , stator reference currents I_{abc}^* , the reference flux and torque stator current components I_{ds}^* and I_{qs}^* , the estimated flux, electromagnetic torque T_e^* .

From the Fig. 6, it can be seen that a good tracking performance is achieved, the rotor speed track the commanded speed with small overshoot. The motor torque is maximum ($1.5 \times$ Rated torque) at initial and decreases when steady state is reached.

At the start the motor draws high current because a high torque is required to increase the speed.

In this experiment the flux reference is set to 0.51 Wb. From Fig. 7, it can be seen that the estimated flux increases from zero and follows the reference flux.

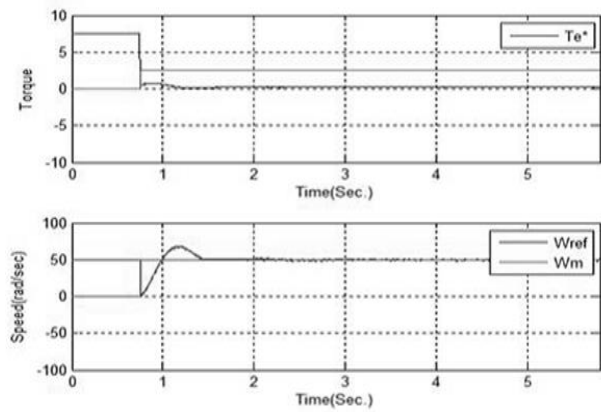

Fig.6. Speed and Torque vs Time

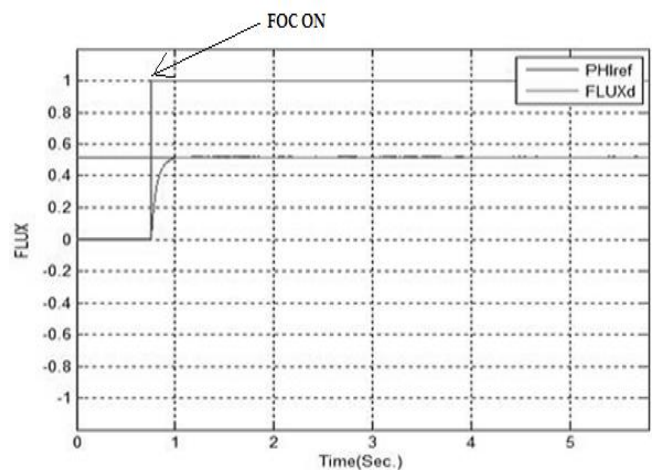

Fig. 7. Reference and Estimated Flux vs Time

This results in a step in the d-current reference according to $i_{ds}^* = L_m / \lambda_r^*$. From this it can be said that the d-current, should remain constant during the experiment, since the flux reference and L_m are constant. From Fig. 8, it can be noticed that the estimated d-axis current follows reference d-axis current.

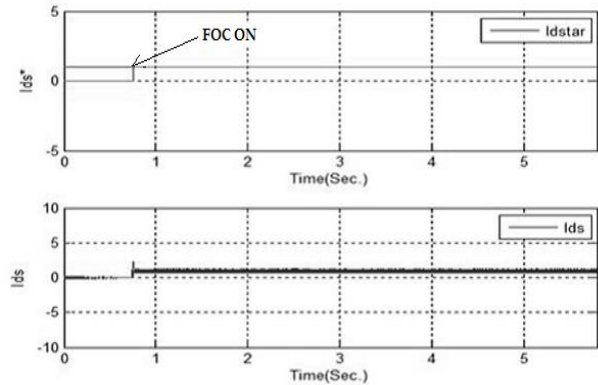

Fig. 8. Reference and Estimated dq-axis currents vs Time

From the three phase stator current waveform shown in Fig.9, it is found that the shapes of the waveforms are sinusoidal with a 120 degree phase shift apart.

The expanded view of these currents is shown in Fig. 10 from which it can be noticed that there are some disturbances in the current measurement, which are due to noise which originates from the switching of the IGBTs in the inverter.

6.2 Experiment No.2

This experiment is to observe the performance of the drive when a load torque of 4.75 N-m is applied from standstill to the motor for set speed of 50 rad/sec.

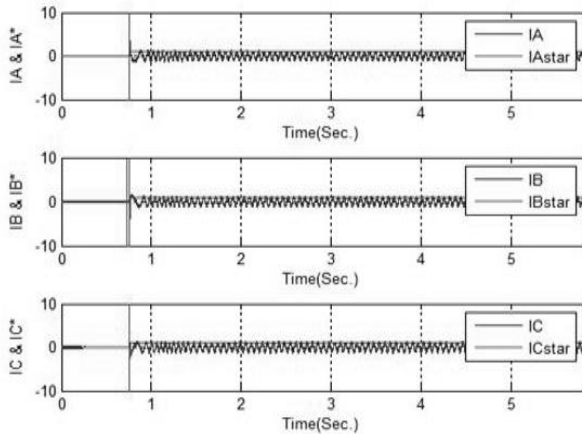

Fig. 9. Iabc and Iabc* vs Time

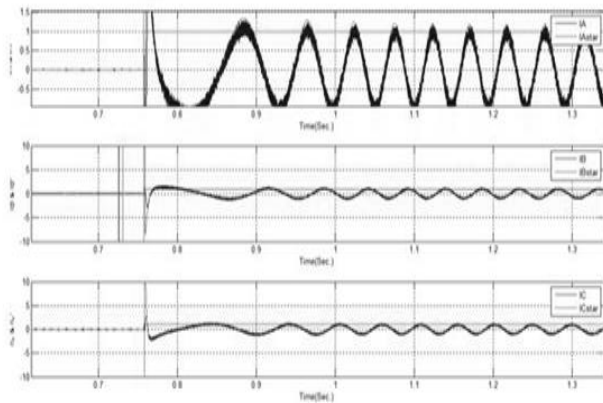

Fig. 10. Expanded view of Iabc and Iabc* vs Time

The stator phase 'a' current reference is significantly increased as the load applied is increased and the q-axis stator current has high value at initial when load is applied which can be observed in Fig. 11 and Fig. 12.

From the Fig. 13, it can be seen that a good tracking performance is achieved, the rotor speed track the commanded speed with small overshoot. The motor torque is maximum (1.5 x Rated torque) at initial and decreases when steady state is reached.

In this experiment the flux reference is set to 0.51 Wb. From Fig. 14, it can be seen that the estimated

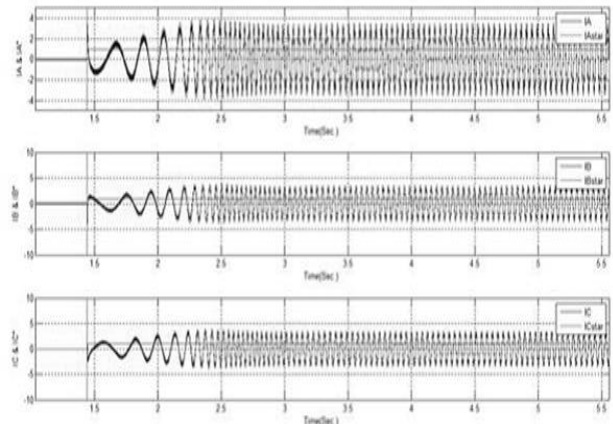

Fig. 11. Iabc and Iabc* vs Time

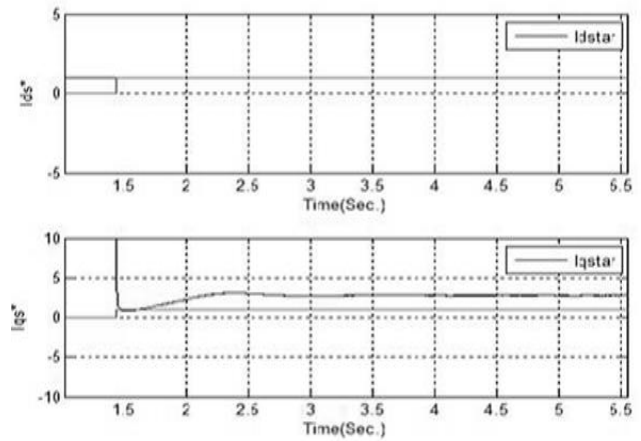

Fig. 12. Reference and Estimated dq-axis current vs Time

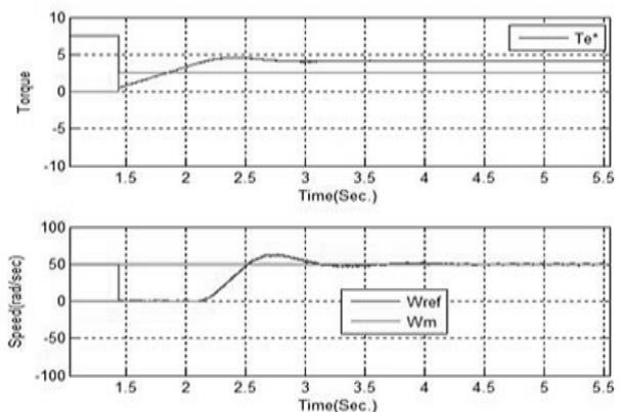

Fig. 13. Reference and Estimated Speed, Torque vs Time

flux increases from zero and follows the reference flux This results in a step in the d-current reference according to $i_{ds}^* = L_m / \lambda_r^*$. From this it can be said that the d-current should remain constant during the experiment, since the flux reference and L_m are constant.

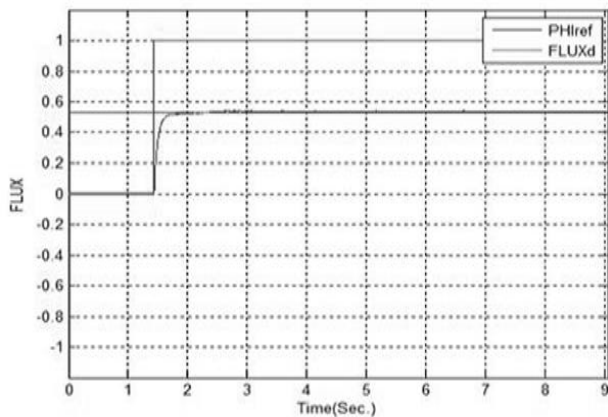

Fig. 14. Reference and Estimated Flux vs Time

6.3 Experiment No.3

The last experiment is to test reversal of rotation of the motor. As the reference speed is set to -20 rad/sec, the phase sequence gets reversed to rotate the motor in reverse direction.

The response when load of $4.75\text{N}\cdot\text{m}$ was applied from standstill for very low speed of -20 rad/sec is shown in Fig. 15 and Fig. 16.

Reference and the estimated flux and d-axis stator current, responses are same as in earlier experiment.

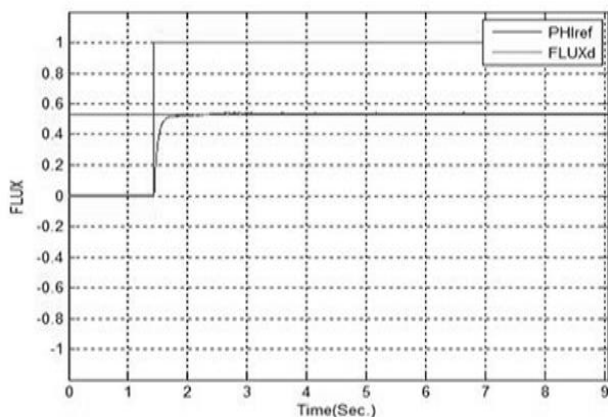

Fig.15. Reference and Estimated Flux vs Time

However, the reference torque, speed and q-axis stator current reverses due to reversal of rotation of motor.

The set speed is very low and hence significant disturbances in the speed and reference torque response were clearly observed.

7. Conclusion

This paper explains the theoretical and practical aspects used in the implementation of indirect rotor field oriented control for current controlled voltage source inverter fed induction motor drive incorporating conventional PI controller. The proposed control strategy is successfully

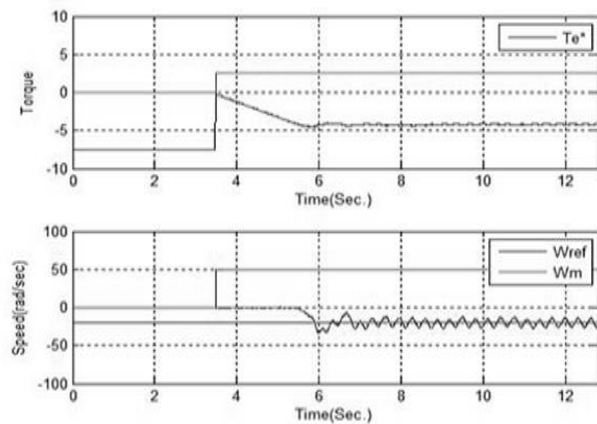

Fig. 16. Reference and Estimated Speed, Torque vs Time

implemented using a digital signal processor board DS 1202 on 0.75 KW induction motor. The experimental results presented in this paper shows that the motor speed, torque, stator currents and flux follows the references closely.

References

1. Sharjil Rahman and Aidil Azwin Bin Zainal Abidin, A Review on Induction Motor Speed Control Methods, In: International Journal Of Core Engineering & Management (IJCEM), Volume 3, Issue 5, August 2016.
2. Field Orientated Control of 3-Phase AC-Motors, In: Literature Number: BPRA073 Texas Instruments, Europe, February 1998.
3. Hamid Khan, Field Oriented Control, In: Application Note, Polytech'Clermont-Ferrand 2008.
4. Ms. Rucha Sardar and Prof. A.R. Soman, Field Oriented Control Technique for Speed Controlling of Induction Motor, In: International Journal of Control Theory and Applications, 9(10), 2016, pp. 4485-4491.
5. Ashish Chourasia, Vishal Srivastava, Abhishek Choudhary and Sakshi Praliya, Comparison study of Vector Control of Induction Motor Using Rotor Flux Estimation by Two Different Methods, In: International Journal of Electronic and Electrical Engineering, Volume 7, Number 3 (2014), pp. 201-206.
6. dSPACE MicroLabBox – Compact Power in the Lab, In: https://www.dspace.com/en/inc/home/news/dspace_pressroom/press/1502001.cfm.
7. P.M. Palpankar, R.U. Ghanmare, & N.Makade, A Generalized Dynamic Model of Induction Motor using Simulink, In: ITSI Transactions on Electrical and Electronics, Volume -1, Issue -5, 2013
8. Raj Irudayaraj, Mathematical Modeling and Analysis of Different Vector Controlled CSI Fed 3-Phase Induction Motor Drive, In : Journal of Applied Mathematics, Volume Engineering, Volume -1, Issue 5, 2013.

9. Aleck W. Leedy, *Simulink / MATLAB Dynamic Induction Motor Model for Use as a Teaching and Research Tool*, In: International Journal of Soft Computing and Engineering (IJSCE), Volume-3, Issue-4, September, 2013, pp 102-107.
10. V. Dhanunjanaidu, K. Chakradhar, K. Madhuri, D. Nalini and B. Koormarao, *Simulink Implementation of Indirect Vector Control of Induction Machine Model*, In: International Journal of Engineering Research and Applications, Vol.4, Issue 4 (Version 1), April 2014, pp.402-410.
11. Vivek V. Puranik, Vijay N. Gohokar, *Simulation of an Indirect Rotor Flux Oriented Induction Motor Drive using Matlab/Simulink*, In: International Journal of Power Electronics and Drive Systems(IJPEDS), vol.8, No.4,Dec 2017, pp 1693-1704.
12. Ali Saghafinia, Hew W. Ping, M. Nasir Uddin and Atefeh Amindoust, *Teaching of Simulation an Adjustable Speed Drive of Inducing Motor Using MATLAB/ Simulink in Advanced Electrical Machine* In:13th International Educational Technology Conference, Procedia - Social and Behavioral Sciences,Vol.103(2013), pp 912-921.
13. Marizan Sulaiman, Fizatul Aini Patakor and ZulkifilieIbrahim, *DSP BASED IMPLEMENTATION OF FIELD ORIENTED CONTROL OF THREE PHASE INDUCTION MOTOR DRIVE*, In: International Journal of Research in Engineering and Technology, Volume: 02 Issue: 09, Sep-2013,
14. Karim Negadi, Abdellah Mansouri and Rabeh Kourek, *Hardware Implementation of Vector Control of Induction Motor Drive without Speed Encoder Using an Adaptive Luenberger Based MRAS Observer*, In: Leonardo Electronic Journal of Practices and Technologies, Issue 20, January-June 2012, p. 99-114
15. T. Gallah, R. Trabelsi, R. Abdelati, A. Ben Ali and A. Khedher, *dSpace DS-1104 implementation of Field Oriented Control for Induction Motor*, In: 10th International conference on Sciences and Techniques of Automatic control & computer engineering, December 20-22, 2009, Hammamet, Tunisia
16. A. Abbou, T. Nasser, H. Mahmoudi, M. Akherraz, A.Essadki, *Induction Motor controls and Implementation using dSPACE*, In: WSEAS TRANSACTIONS on SYSTEMS and CONTROL, Issue 1, Volume 7, January 2012
17. Osama Mohammed, Nagy Abed, *REAL-TIME SIMULATION OF ELECTRIC MACHINE DRIVES WITH HARDWARE-IN-THE-LOOP*, In: American Society for Engineering Education, 2008, page 13,1026,1-12
18. Y.Chintu Sagar, Dr.K.Sri Gowri and G. Kumaraswamy, *Implementation of dSPACE Controlled CSVPWM Based Induction Motor Drive*, In: International Journal of Engineering Research & Technology (IJERT), Vol. 2 Issue 11, November – 2013.

AUTHORS BIOGRAPHIES



Vivek V. Puranik was born in Miraj, Maharashtra, India in 1962. He received his Bachelor's degree in electronics and power engineering from Nagpur University, Nagpur, Maharashtra, India in 1985 and master degrees in electrical control systems engineering from Shivaji University

Kolhapur, Maharashtra, India in 2007. Presently he is pursuing PhD from Sant Gadge Baba Amravati University, Amravati, Maharashtra, India.

He is having rich teaching and industrial experience. His research interest includes automatic control, Power Electronics and drives and Artificial Intelligence.



Dr. V.N.Gohokar, has obtained his Doctorate Degree from Amaravati University, India in 2005. He has 30 years, teaching experience in Electrical Engineering Program. He has wide experience in the field of Administration and Research.

He has published more than 40 papers in National and International Journals and Conferences. His area of research is Power System Protection and Distribution Automation. Presently he is working as a Professor in the Department of Electrical Engineering at MMCOE, Pune, India.

