

Design of a Hybrid Accumulator Architecture for Harvesting and Storing of Power in WSN using an Adaptive Power Organizing Algorithm

Senthilkumar.R¹, Dr.G.M.Tamilselvan²

¹Research Scholar, Anna University, Chennai

²Professor, Dept.of Electronics and Communication Engineering, Bannari Amman

Institute of Technology, Sathyamangalam.

¹rajsen1985@gmail.com,²tamiltamil@rediffmail.com

Abstract: *Converting the harnessed energy from the environment or other energy sources to electrical energy is referred to as energy harvesting. The need of energy harvesting in wireless sensor networks is an essential issue to be handled to allow adequacy of the innovation in a wide range of utilizations. The maximum energy should be harvested from the solar panels and it should be stored and managed effectively to power the nodes in the wireless network. For this purpose a solution proposed in this paper utilizes a hybrid accumulator architecture that combines the advantages of an effectively controlled "Battery and Ultracapacitors" where the power stream from a li-ion battery is combined with an Ultracapacitors for power upgrade and conveyance to the stack proficiently and using a new adaptive power organising algorithm management of power in the battery and capacitor can be performed. The proposed design is implemented in Simulink and the results show the effect of the hybrid design.*

Keywords: *Energy harvesting, Adaptive power organising algorithm, Li-ion battery, Ultracapacitor.*

1. Introduction

High attention is gained from both the research community and actual users by the wireless sensor networks (WSNs). Wireless sensors can enable a variety of applications including interactive environments for medicine, military target tracking, environmental monitoring networks and detection of chemical and biological weapons [Akyildiz,Su, et al., (2002)]. One of the advantage of wireless sensors networks(WSNs) is the ability to function unattended in harsh environments in which contemporary human-in-the-loop monitoring patterns are inefficient, risky and sometimes infeasible [Amitand,Chandrakasan, et al., (2001)].

Sensor nodes present in WSNs are generally battery-powered devices, the critical aspects is to reduce the energy consumption of nodes, to facilitate that the network lifetime can be prolonged to reasonable times [Anastasi,Conti, et al., (2007)]. A greater number of sensors allows for detecting over higher geographical regions with better accuracy [Min,Bhardwaj, et al., (2001)]. Typically, a sensor node is a tiny device that includes three basic major components: (i) processing subsystem for local data processing and storage(ii) wireless communication subsystem for data transmission (iii) sensing

subsystem for data acquisition from physical encompassing environment [Beatrys,Nogueira, et al., (2003)]. In addition, to perform the programmed task a power source supplies the energy needed by the device. This power source frequently comprises of a battery with a fewer energy budget and the battery provides the average power demand [Vijay, et al., (2002)] [Rahul, et al., (2003)].

Li-ion batteries are one of the efficient battery power system used in WSN. These batteries have to work with long life time [Jamal,Kamal, (2004)]. A few arrangement methods have been proposed to boost the lifetime of battery-powered sensor nodes. To ensure coverage guarantees some of these include storage, routing and data dissemination protocols, adaptive sensing rate, redundant placement of nodes and tiered system architectures [Jennifer,Mukherjee, et al., (2008)].The lifetime remains bounded and finite while all the above techniques optimize and adapt energy usage to make best use of the lifetime of a sensor node. The above techniques do not help to discard energy-related inhibitions but between batteries replacements it helps to prolong the application lifetime and/or the time interval [Qin,Yang, et al., (2007)]. One of the solution is solar energy harvesting. Solar energy harvesting have been proposed to extend the lifetime of wireless networks beyond the limitations which have been previously imposed by batteries [Yasser, et al., (2005)].Depending on the aptness of the environment where the sensor will be deployed from the environment such as solar panels secondary power supply may harvest power that may be added to the node [Caisheng,Nehrir (2008)]. Chemical double layer capacitors also support this energy harvesting [Akyildiz,Ian, et al., (2004)].

Depending on a diode connecting the cell with the rechargeable battery most of the solar energy harvesting solutions for wireless sensor nodes presents a simple on/off-threshold charge mechanism [Chris,Wagner, et al., (2003)]. Unfortunately, a diode-based solution is extremely low cost, but the working point of the cell is set by the battery voltage and it cannot be adjusted to maximize the energy transfer in changing environment. This problem is addressed by substituting the diode-based solution with a Maximum Power Point Tracker (MPPT) system [Guilar,Kleeburg, et al., (2009)]. This approach requires the development of adaptive systems to

transfer the energy generated by the solar cell into storage elements, such as batteries or supercapacitors, while maintaining the working point of the PV cell around the optimal one [Abbasi,Ahmed, et al., (2007)]. Instead of supercapacitors due to their high specific power the emerging application of wireless sensor networks continues to drive the need for ultracapacitors (UC) [Alippi,Galperti (2008)]. The normalized voltage swing system therefore reduces the strain on the battery at open circuit for batteries and the UC absorbs and supplies the large current pulses, while the UC voltage swing is 0.2 and is limited by the battery [Lukicet, et al., (2006)].

Light striking a silicon semiconductor causes electrons to flow, creating electricity. Solar power generating system takes the advantage of this property to convert light energy directly into electrical energy. Solar powered Photovoltaic panel (or solar module) converts the sun's rays into electricity by exciting electrons in silicon cells using the photons of light from the sun. PV module, which contains series connected identical cells, is exposed to irradiance and temperature. Based on this, it will be expected to generate the same amount of power. The solar power produces direct current, which is then fed into the inverter to convert into alternating current for homes [Akinyele,Rayudu].

A hybrid accumulator is designed to extract maximum energy from solar panels and to store the energy, then the stored energy is provided to a wireless sensor network and managed by using adaptive power organising algorithm. The rest of the paper is organized as follows: Section 2 discusses the related work to our proposed method. The proposed method is present in section 3. Section 4 introduces the simulation results of our proposed method and the comparison with the other existing methods. In section 5, the overall conclusion of this paper is presented.

2. Related Work

Some of the recent works related to solar energy harvesting and power management in WSN is explained below:-

To achieve good energy efficiency and system performance in energy harvesting real-time systems Liu, Shaobo, *et al.* [Liu,Lu, et al., (2012)] have proposed a harvesting-aware power management algorithm. Static and adaptive scheduling methods combined with dynamic voltage and frequency selection is utilized by the proposed algorithm to achieve good system performance under timing and energy constraints. In this approach, the scheduling and optimization problem was simplified by separating constraints in timing and energy domains. By exploiting task slack with frequency selection and dynamic voltage and minimizing the waste on harvested energy that algorithm achieved improved system performance.

For ME energy harvesting Li, Ping, et al. [Li,Jia, et al., (2011)] have proposed a Ferro-nickel (Fe-Ni)/PZT

H-type fork magneto electric (ME) composite structure and an energy management circuit. Compared with the conventional rectangular composite structure the resonant fork composite structure with a high Q value confirmed a higher ME voltage coefficient and a more robust power coefficient. The resonant fork composite structure can acquire an output power of 61.64 μ W at an ac magnetic field of 0.2 Oe. The fork structure of the ME sensitivity attains 11 V/Oe. For producing an ac magnetic field of 0.2–1 Oe at a distance of 25–50m, an active magnetic generator and a magnetic coil antenna are used for fragile magnetic field environment. For weak electromagnetic energy harvesting a management circuit of the power supply with matching circuit, instantaneous-discharge circuit and energy-storage circuit was developed appropriately. The management circuit can constantly collect feeble energy from the fork composite structure for a prolonged period and furnish an excessive-power output in a very quick cycle. At the same time the voltage across the storage supercapacitor used to be over 0.36V, a wireless sensor network node driven by the instantaneous-discharge circuit with an output power of 75mW at a distance of over 60m.

A control method that minimized the usage of storage was proposed by Levron, Yoashet.al. [Yoash,Shmilovitz, et al., (2011)].The power storage potential can be decreased by the technique of comparing data transmission rate as close as to the accessibility of harvested power. Wireless transmission techniques fed by ambient harvested energy sources can function continually, with no requirement of battery replacement. Such methods are perfect for applications with restricted or intricate accessibility. Ambient power sources showcase a stochastic nature, so a power storage device must save the harvested power. An audio recording sensor was planned and simulated making use of SPICE to authenticate the proposed controller. For this method, the dimensions of storage gadget used to be diminished by a factor of 24.

Suryadevara, Nagender Kumaret.al, [Suryadevara,Mukhopadhyay, et al., (2015)] have proposed the design and development of a smart monitoring and controlling method for household electrical appliances. The system mainly monitors electrical parameters of household appliances such as current and voltage and therefore computes the consumed power. The novelty of that approach was the application of the controlling mechanism of appliances in specific ways. The developed approach was of less expensive and flexible in operation and thus can store electricity expenditure of the consumers. The prototype has been widely established in real-life instances and experimental outcome are very inspiring.

Erol-Kantarci and Hussein T. Mouftah [Melike,Mouftah,et al., (2011)] have proposed an approach to assess the performance of an in-home

energy management (iHEM) application. The performance of iHEM used to be in comparison with an optimization-based residential energy management (OREM) scheme whose goal was to diminish the energy costs of the customers. It was shown that iHEM reduced the following: energy expenditures, contribution of the customers to the peak load, carbon emissions of the household. Its savings are adjacent to OREM. Alternatively, iHEM application was more malleable as it permitted communication between the controller and the purchaser making use of the wireless sensor home area network (WSHAN). Under the presence of local energy generation capacity, prioritized appliances and for actual-time pricing they have assessed the efficiency of iHEM. Efficiency of iHEM demonstrates that diminished the expenditures of the buyers for every case. Moreover, packet delivery ratio, delay and jitter of the WSHAN were enhanced because of the packet dimension of the monitoring purposes.

3. Energy Harvesting and Power Management

Energy harvesting source are basically diverse from that in using a battery as the harvested energy from photo voltaic cells typically varies with time in a non-deterministic manner. A wide variety of energy harvesting is now available. Through photovoltaic (PV) conversion solar energy harvesting provides the highest power density. The extraction of energy from solar cells is difficult due to its strong nonlinear characteristics and variable operating conditions due to weather change. Also the energy transfer from the solar cells is influenced by illumination conditions vary along the day. A simple and low cost way to extract and store the energy from PV source is, to connect the solar panel directly to the battery with diode. For that we propose, a design of hybrid accumulator architecture with the advantages of ultra-capacitors, in terms of charge/discharge cycle process, the Li-ion batteries for their energy density and costs. The power between this ultra-capacitor and the battery is managed efficiently using a new adaptive power organising algorithm which manages the energy flow in the storage unit and supplies the power to the sensor nodes when there is a demand on the network. The schematic diagram of our proposed method is shown in figure 1.

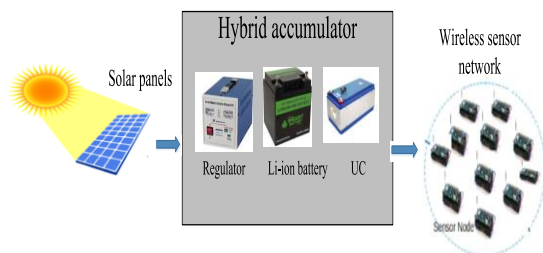

Figure 1: Schematic diagram of our proposed method

From figure 1 it is visible that the solar panels get the energy directly from the natural source of energy. The solar panels are directly connected to a hybrid accumulator. The proposed hybrid accumulator architecture consists of two units namely harvesting unit and storage unit. Harvesting unit is the core of this design. The harvesting unit consists of a voltage regulator and a number of solar cells connected in series and parallel. The storage unit consist of a li-ion battery with an ultra-capacitor. The ultra-capacitor has the main responsibility to store and control the power delivered from the harvesting unit. The ultra-capacitor charges when the power level exceeds than the need or discharges when there is a need for power. The storage unit supplies the stored power to the nodes in the wireless sensor networks.

In our proposed method the design of a hybrid accumulator is a predominant endeavour. This hybrid accumulator design is accountable for storage, control, manage and supply the power extracted from the solar panels. This accumulator design consists of designing two units such as harvesting unit and storage unit. Figure 2 shows the architecture of our proposed system.

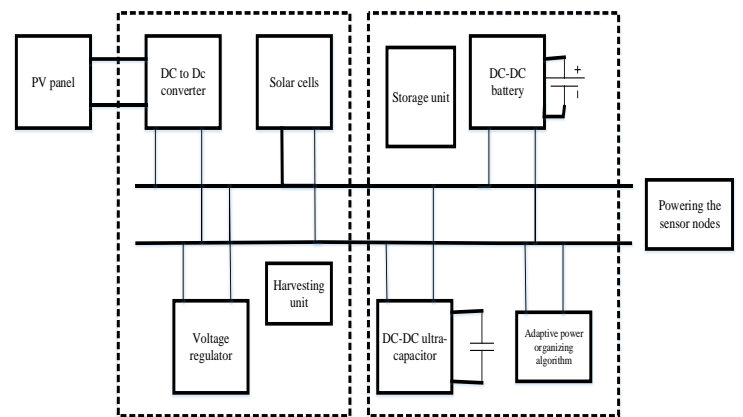

Figure 2: Proposed system architecture

From figure 2 it is visible that in our proposed system architecture to the dc power bus three dc-dc converters are connected in parallel. The power bus is the power line that connects the devices for transmitting the produced power. The first converter is “DC-DCPV converter”, where the PV panel is interfaced to the dc power bus, the second converter “DC-DC battery converter” connects the dc bus to the battery and the third is “DC-DC ultra-capacitor converter”, in which the ultracapacitor is connected to the dc bus. The internal power bus is the main power supply of the electronic system utilized by sensor node. The power range of the proposed photovoltaic scavenger is in the range of 5W. The average power obtained by this source during a day is about 150mW that is sufficient for our application where the average load power is 100mW. The harvesting unit contains the solar panel, which is connected to the dc-dc converter and the output from

the solar panel is regulated using voltage regulator to regulate the voltage level required for the power storage. The storage unit consists of battery to store the energy and the battery can be protected from overcharging and discharging stresses in order to prolong its lifetime. The extra power required by the load or generated by the fluctuating source is smoothed by the ultra-capacitors elements

Moreover, the energy stored in the battery is designed in order to supply the load for the whole day. The architecture reported in Figure 2 is aimed to the maximization of the power conversion efficiency from the PV source to the load. In fact, when the power source is available, the energy flows directly from the source to the load through the dc-dc PV converter. Moreover, with the power architecture of Figure 2, it is possible to parallel different power sources. In fact, other energy sources can be connected by a converter to the same bus without changing the system architecture or the power management control. Thus, by including a hybrid accumulator system, the battery can be protected from overcharging and discharging stresses in order to prolong its lifetime. The extra power required by the load or generated by the fluctuating source is smoothed by the ultra-capacitors elements. In our case of study the dc bus is at 3.3V (V_{BusDC}), the solar panel has a voltage about 6V (V_{VPV}), the maximum voltage utilizable by the super capacitor is of 2.5V and the lithium battery has minimal voltage of 3.7V (V_{Battery}).

3.1 Energy harvesting unit

Converting energy from one form to the other or scavenging energy is referred to as energy harvesting. To power the sensor node energy is harvested from external sources and in turn, expands their lifetime and capability. Provided the energy-usage profile of a node, energy harvesting approaches would see fractional or all of its energy requirements. A popular and widespread method of energy harvesting is converting solar energy to electrical energy. Solar energy is overwhelming the intensity of direct sunlight can't be managed; however it is a expectable energy source with daily and periodic patterns. A usual energy harvesting system has three constituents, the Harvesting architecture, the Energy source, and the Load. The ambient source of energy to be harvested is referred to as energy source. Harvesting architecture includes mechanisms to harness and convert the input ambient energy to electrical energy. Load denotes to activity that consumes energy and performs as a sink for the harvested energy.

3.1.1 DC-DC power converter

The input of dc-dc converter is an unregulated dc voltage. The dc-dc converter converts the unregulated voltage into regulated voltage which is required. The ideal dc-dc converter exhibits 100% efficiency; in practice, efficiency from 70% to 95% is

typically obtained. This can be achieved by using switched-mode (chopper) circuits, whose elements dissipate negligible power. Pulse-width modulation (PWM) allows, to control and regulation of total output voltage. This approach is also employed in applications like alternate current, which includes high efficiency of, dc-ac power converters (like inverters and power amplifiers), ac-ac power converters and ac-dc power converters. The dc-dc PV converter is shown in Figure 3.

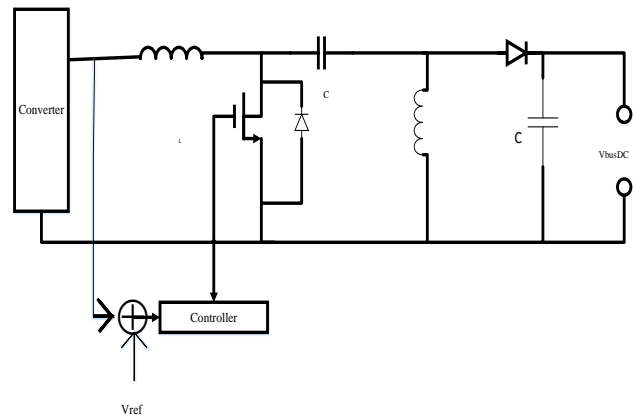

Figure: 3 Photovoltaic conversions with input voltage controller

The conversion ratio can be stepped down to the bus voltage as

$$\frac{V_{BUSDC}}{V_{Battery}} = \frac{D_C}{1 - D_C} \quad (1)$$

where, D_C is the converter duty-cycle, V_{BUSDC} is the dc bus voltage and $V_{Battery}$ is the battery voltage. In the implementation, a coupled inductor was used, thus reducing the magnetic element to one, as shown in Figure 3. The input voltage of the converter is controlled by a feedback loop and the reference is decided either by the control on the ultra-capacitor voltage or by the source MPPT, depending on the state of the adaptive power organising algorithm.

3.1.2 Regulator

The solar power charge regulator guarantees that this battery is commonly logging in appropriate conditions. The extracted power from the solar panels is used in a maximum range utilising with the aid of regulator. Moreover to this the regulator sustains knowledge of a state of charge (SoC) of any battery, to guarantee suitable charging, discharging of the battery, The SoC will be estimated on the basis of the actual voltage of the battery. By measuring the battery voltage being programmed in the storage technology used from the battery, one's regulator will more commonly realize ones exact common steps where the battery would become overcharged as well as excessively discharged. The

regulator will compare the low voltage from solar panel V_{in} and regulate the voltage level for the battery storage. Figure 4 displays the basic regulator circuit.

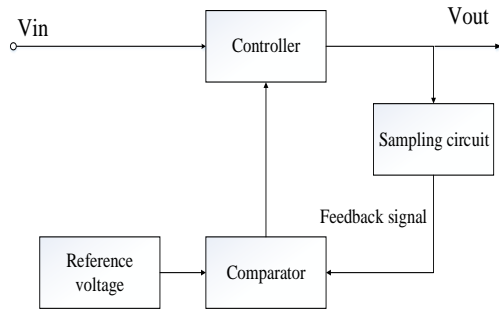

Figure 4: Voltage regulator

3.2 Power control and management unit

In wireless sensor network, each node may have different environmental harvesting opportunity, so appropriate power management strategies should be used to minimize the power consumption. Instead of just minimizing the total energy consumption, it turns out to be essential to acclimate the power management scheme to account for these spatial temporal variations. When the load current is small, the converter in power management circuit is controlled such that irrespective of the battery voltage variation the battery discharges at a constant rate and it charges the ultra-capacitor. By the average load demand, the discharge rate of the battery is determined and is controlled via an appropriate feedback mechanism. The current is controlled so as to not exceed the safety limit to protect the battery. At this time, the ultra-capacitor is charged at a constant current. Secondly, when the load current is high, both the battery and the ultra-capacitor supply current to the load. By controlling the battery current at a constant value throughout the operating cycle, the battery can be kept in extremely steady state; it is therefore electrically and thermally preferred for the sake of a safe and long lifetime. Most importantly, the hybrid provides much higher power without drawing excessive current from the battery.

3.2.1 DC-DC battery converter

The li-ion battery utilised on this storage unit is merely utilised as a backup energy source. The storage unit is accountable for store and manage the energy and provides it to the sensor nodes in the wireless networks. With this form of architecture the optimal technique for energy harvesting is acquired with increasing lifetime of the batteries. The dc-dc battery converter is a bidirectional Buck- Boost converter, as proven in figure 5, to charge and to make use of the battery whilst at the same time based on the working stipulations.

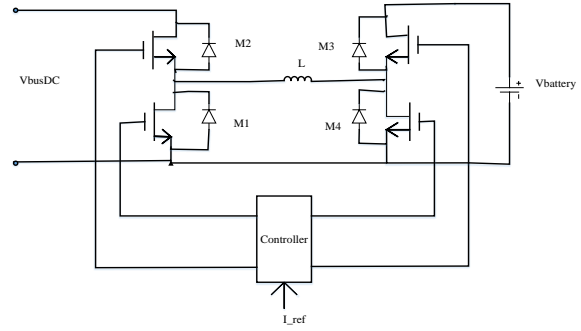

Figure 5: Bidirectional Buck-Boost converters connected to the Battery

This choice is dictated by the required voltage level of the battery with respect to the dc power bus; in fact, the lithium battery has a nominal voltage of 3.7V and the dc bus voltage is 3.3V. This converter operates like a Buck-Boost by turning on the switch M2 and M3 during the “on phase” and by turning on the switch M1 and M4 during the “off phase”. In CCM operation the conversion ratio is given by

$$\frac{V_{busDC}}{V_{Battery}} = \frac{D_c}{1 - D_c} \quad (2)$$

This type of converter has a current controlled loop and the power organising algorithm decides the current reference value, which is either positive or negative depending on the working conditions of the battery (charge or discharge).

The power delivering capability of a battery is given by

$$P_{DISCHARGE\ BATT}(SoC) = V_{min} \cdot ((V_{OC}(SoC) - V_{min}) / R_{DISCHARGE\ BATT}(SoC)) \quad (3)$$

$$P_{CHARGE\ BATT}(SoC) = V_{max} \cdot ((V_{max} - V_{OC}(SoC)) / R_{CHARGE\ BATT}(SoC)) \quad (4)$$

Where $P_{DISCHARGE\ BATT}(SoC)$ is the maximum amount of power that can be released from a source, V_{min} is the minimum voltage allowed on the source during discharge. V_{max} is the maximum voltage allowed on the source during charge. $R_{(DIS)CHARGE}$ is the equivalent (dis)charge source resistance. Resistors are rated by the value of their resistance and the electrical power given in watts, that they can safely dissipate based mainly upon their size. Every resistor has a maximum power rating which is determined by its physical size as generally, the greater its surface area the more power it can dissipate safely into the ambient air or into a heatsink. Resistors are devices used in electronic circuits to provide a known resistance to the flow of electrical current. They are used to scale and limit the signal that is passing through them to help achieve the desired performance of the circuit. $V_{OC}(SoC)$ is the open circuit voltage of the source at SoC.

3.2.2 DC-DC ultracap converter

The dc-dc ultracap converter is a bidirectional converter based on the synchronous buck topology, as reported in Figure6.

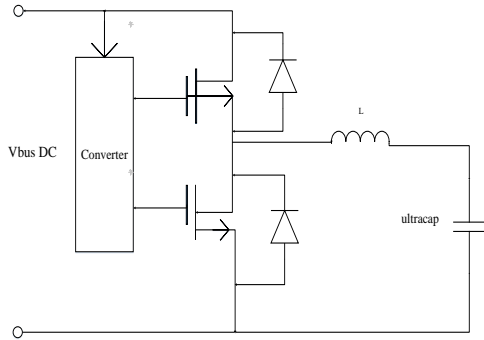

Figure 6: Bidirectional Buck converters connected to the ultra-capacitor

It operates in step-down mode when the power flows from the dc bus to the ultra-capacitor, and operates in step-up mode when the power flows in the opposite direction. The converter controls the dc bus voltage and it behaves as a sink or a source depending on the instantaneous power conditions. By utilizing the dc-dc converter, the ultra-capacitors are connected in parallel without requiring an overvoltage protection system on each element that is needed in the serial connection. If the consumption of the wireless node is high during the period of time without irradiation, a lithium battery is used decreasing the size of the energy storage unit. During the charge of the battery the system works as in the previous description, and the ultra-capacitor system allows a stable charge process. When irradiation is not present and the ultra-capacitor system is almost discharged, the operation of the battery converter must be inverted by the power manager. In this case the energy required for the super-capacitor is the energy utilized to compensate the input energy variations with respect to the load requirement and the battery charge profile. The power delivery capability of ultra-capacitor is determined by the following equation:

$$P_{DISCHARGE UC}(SOC) = V_{MIN} \left[\frac{V_{OC}(SOC) - V_{MIN}}{R_{DISCHARGE UC}(SOC)} \right] \quad (5)$$

where

$$R_{DISCHARGE UC}(SOC) = \frac{V_{OC INITIAL}(SOC) - V_{FINAL}(SOC)}{I_{LOAD}} \quad (6)$$

$$V_{FINAL}(SOC) = V_{OC FINAL}(SOC) - IR_{OHMIC} \quad (7)$$

$$V_{OC} = Q/C$$

The discharge resistance of UC is a function of both the IR losses as well as during the discharge the fact that the state of charge of the battery decreases radically. The equations for charge are given as follows:

$$P_{CHARGE}(SOC) = V_{MAX} \left[\frac{V_{MAX} - V_{OC}(SOC)}{R_{CHARGE UC}(SOC)} \right] \quad (8)$$

$$R_{CHARGE UC}(SOC) = \frac{V_{FINAL}(SOC) - V_{OC INITIAL}(SOC)}{I_{LOAD}} \quad (9)$$

$$V_{FINAL}(SOC) = V_{OC FINAL}(SOC) + IR_{OHMIC} \quad (10)$$

3.2.2.1 Working principle

Ultra-capacitors also called as electric double layer capacitor, where the electrical charge stored at a metal/electrolyte interface is exploited to build a storage device. The high content of energy stored by ultra-capacitors came from activated carbon electrode material consuming the enormously high surface area and the short distance of charge separation produced by the opposite charges in the interface between electrode and electrolyte. Randomly distributed ions in electrolyte, when charged under electric field move toward the electrode surface of opposite polarity. Rather than a chemical reaction it is purely physical phenomena and hence highly reversible process, which result in high cycle life long shelf life, high power, and maintenance-free product. Figure 7 shows the working principle of our proposed ultra-capacitor. This shows when the voltage potential applied to the UC cell, the applied voltage potential on the positive electrode attracts the negative ions in the electrolyte, while the potential on the negative electrode attracts the positive ions. It defines the potential before charging and after charging. It stores the electricity by physically separating positive and negative charges so that it provides super-fast rate for charging and discharging. Figure 8 shows the charging and discharging mechanism of UC.

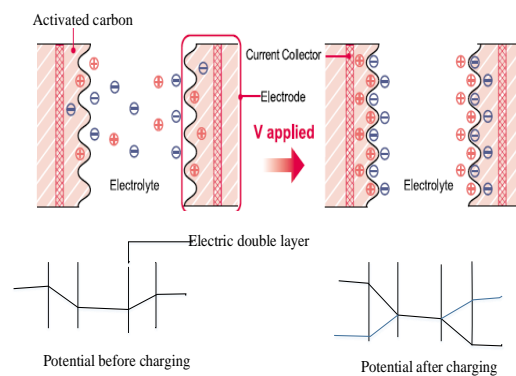

Figure 7: working principle of ultra-capacitor

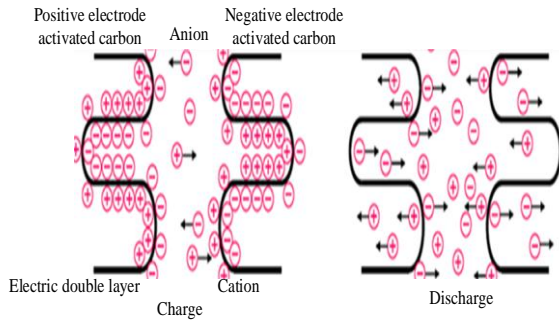

Figure 8: charging and discharging mechanism of ultra-capacitor

3.2.2.2 Energy Equation for Ultra capacitor

Different units between ultra-capacitor (Farad) and battery (Ampere hour) can bring compatibility issues when adopting ultra-capacitor in their system. The amount of energy stored in ultra-capacitor can be easily calculated by using following equation.

$$Energy(J) = 1/2 \times Capacitance(F) \times Voltage^2 (V) \quad (11)$$

It can be converted from Farad for Ultra capacitor to Watt-hour unit, which is normally used in conventional rechargeable battery.

$$Energy(Wh) = Energy(J) / 3600(s) \quad (12)$$

From activated carbon electrode material the high content of energy stored by ultra-capacitor is compared to conventional electrolytic capacitor, which is having the high surface area and the short distance of charge separation produced by the opposite charges in the interface between electrode and electrolyte. Compared with rechargeable battery Ultra-capacitors have different charge & discharge characteristics. Battery has voltage plateau region but during charge and discharge ultra-capacitors displays only linear relationship with voltage. The linear relationship with voltage can alter to constant voltage by merely connecting DC-DC converter. The amount of energy stored in Ultra capacitor can be easily calculated by measuring voltage.

3.3 Adaptive Power Organising Algorithm

The proposed power management algorithm for the complete hybrid storage system is based on different control states defined by the charge state of the ultra-capacitor. The ultra-capacitor energy is used to switch from a state to another one because it inherently monitors the power balance of the system.

Initially the system will be turned off. From this stage the system wakes up only if some sources can deliver the energy required to start up the control electronic consequently, the system can proceed to the normal state. During this stage the energy comes from the source and it is directed to the ultra-capacitor and to the battery in order to maintain the bus voltage normal-stage. In this stage the control strategies are based on the MPPT of the sources and on the dc bus

voltage regulation. The state diagram switches from the normal state to charge the battery, when the dc bus voltage has reached its nominal values and the energy of the ultra-capacitor exceeds the reference energy.

In these conditions, the dc bus voltage is controlled by voltage loop using the dc-dc ultra-cap converter and the voltage, thus the energy in the capacitor is regulated by changing the charging current of the battery, if it is less than the maximum input current of the charge profile of the battery. When the battery charging current reaches the maximum value, the ultra-capacitor voltage becomes the degree of freedom during this stage. When the ultra-capacitor voltage increases, the algorithm moves towards the over power stage. In this case the source of MPPT is switched to a control loop on the ultra-capacitor voltage that regulates the maximum energy, thus reducing the input power. When the input power decreases and it is lower than the load power, the ultra-capacitor voltage decreases, so the system moves to the battery help stage.

In this stage the control maintains the voltage stable for the dc bus, the MPPT for the source and it uses the battery as a source in order to maintain the voltage of the ultra-capacitor by modulating the battery current level. At the same time the maximum current output level of the battery is limited by the control in order to prolong the battery lifetime. Moreover in order to avoid extra discharge of the battery, the output current limit falls to zero if the voltage of the battery is lower than a threshold value. Finally if the input power is lower than the output power required by the load and the battery is discharged the voltage across the ultra-capacitor decreases until it reaches the threshold voltage associated with the energy and the system goes to the turn off stage.

Pseudo code for adaptive power organising algorithm

- 1) Initially $P_{SC} = 0, P_B = 0$.
- 2) When $E_{gen} < E_{ref}$ the battery starts charging linearly.
- 3) When the battery power $P_B > E_{th}$ it indicates an overvoltage and the ultra-capacitor starts charging and battery discharges.
- 4) The capacitor charges linearly until it exceeds E_{th} .
- 5) When $P_{SC} > E_{th}$ the capacitor needs the help of battery
- 6) Else
- 7) The system goes to initial step (turn off).

The value of the ultra-capacitor is based on the study of the instantaneous power variation of the source or the load in two main states of the algorithm: battery help and battery charge. If the system is correctly designed these two states switch during the day and night. By neglecting the converter losses, the instantaneous power on the ultra-capacitor in the battery charge state can be expressed as follows:

$$P_{UC}(t) = P_{Source}(t) - P_{Load}(t) - P_{Charge}(t) \quad (13)$$

And in the battery help state

$$P_{SC}(t) = P_{Source}(t) + P_{Battery}(t) - P_{Load}(t) \quad (14)$$

If there is a load power increase or an input power reduction during the battery charge state, the battery charging current is reduced in order to regulate the voltage across the ultra-capacitor and under the worst case, it is reduced to zero. Under these conditions equation (13) becomes:

$$P_{SC}(t) = P_{Source}(t) - P_{Load}(t) \quad (15)$$

In the battery help stage when the battery generates the maximum power available for a given current limit I_{max} , the power can be expressed as follows:

$$P_{SC}(t) = P_{Source}(t) + I_{max} V_{battery} - P_{Load}(t) \quad (16)$$

The following analysis is based on the hypothesis, in which the instantaneous power generated or accumulated on the ultra-capacitor can be considered as an uncorrelated random variable for event with the distance of T_{sample} . This interval depends on the fluctuation of the load and source power. Based on a statistical approach, the power generated or accumulated by the ultra-capacitor is described by a probability density function f_{PC} that is different depending on the state of the power controller. Using f_{PC} it is possible to express the probability of extracting power from the ultra-capacitor at a given time t as

$$P(P_{SC}(t) < 0) = \int_{-\infty}^0 f_{PSC}(p) dp \quad (17)$$

Let's denote $P_{SCgen}(t)$ the power generated by ultra-capacitor

$$P_{SCgen}(t) = -P_{SC}(t) \quad (18)$$

Thus the probability that $P_{SCgen}(t)$ is greater than power P at a given time t is

$$P(P_{SCgen}(t) > P | P_{SC}(t) < 0) = \frac{\int_P^{\infty} f_{PSC}(p) dp}{P(P_{SC}(t) < 0)} \quad (19)$$

The extracted energy E_{SCgen} is defined from the extracted power P_{SCgen}

$$E_{SCgen} = \sum_{n=1}^N P_{SCgen}(t + nT_{sample}) T_{sample} \quad (20)$$

where N is the number of subsequent events where $P_{SC}(t) < 0$. From (14), the probability density function of E_{SCgen} is

$$P(E_{SCgen} > E | P_{SC}(t) < 0) = \frac{\sum P(P_{SC}(t) < 0)^n \int_{-\infty}^{E/T_{sample}} \int_{k=1}^n f_{PSC}(p) dp}{P(P_{SC}(t) < 0)} (1 - P(P_{SC}(t) < 0)) \quad (21)$$

Where $f_{\sum_{k=1}^n P_{SC}}$ is the probability density function of the extracted energy E_{SCgen} , is derived by differentiating (21)

$$f_{Esc}(e) = [1 - P(P_{SC}(t) < 0)] \sum P(P_{SC}(t) < 0)^{n-1} f_{\sum_{k=1}^n P_{SC}} \left(\frac{e}{T_{sample}} \right) \quad (22)$$

For example let's consider the case where the input power is constant, the system is working in battery charge mode and when the load is active the power load is at a random variable with an uniform distribution from 0 to 4 W with a sample time of $T_{sample}=10s$. Using (22) the probability density function is calculated and it is noted that in 90% of the cases the energy supplied by the ultra-capacitor is less than 25 J, thus in order to avoid the use of battery during the day. To avoid the battery help we impose

$$E_{RefBC} - E_{Th2} > 25J \quad (23)$$

Assuming $E_{refBC}=2V$ and $E_{Th2}=1V$, the ultra-capacitor value C should be greater than 16.67 F.

The same reasoning should be applied during the night taking into account that the battery is able to supply a maximum current $I_{max}=600mA$. In these conditions the input source is zero and the maximum power supplied by the battery is 2.2 W. Moreover when the load is active the power load $P_{Load}(t)$ is assumed to be a random variable with an uniform distribution from 0 to 2.5W with a sample time of $T_{sample}=10s$. Using (13) we found that in 90 % of the cases the energy supplied by the ultra-capacitor is less than 3J. Thus in order to avoid the turn-off stage we impose:

$$E_{RefBH} - E_{Th1} > 3J \quad (24)$$

Assuming $E_{refBH}=1V$ and $E_{Th1}=0.2V$, the ultra-capacitor value C should be greater than 6.25F.

4. Results and Discussion

The proposed energy management uses the adaptive power organising algorithm to manage power between the battery and capacitor and it also responsible to provide energy to the sensor nodes when there is a demand in the wireless network. The results for the proposed system design are explained in this section. The proposed System configuration is given below:

Operating System: Windows 8

Processor: Intel Core i3

RAM: 4 GB

Converter efficiency:80%

Ultracap leakage current:1mA

Capacity of the battery:20%

Charge current:300 mA

Discharge current:150 mA

Platform: Simulink

4.1 Experimental results

The initial process of our research work is the extraction of energy from the solar panels and harvesting the energy to provide supply to the WSN. The voltage obtained by the solar panels is shown in figure 8.

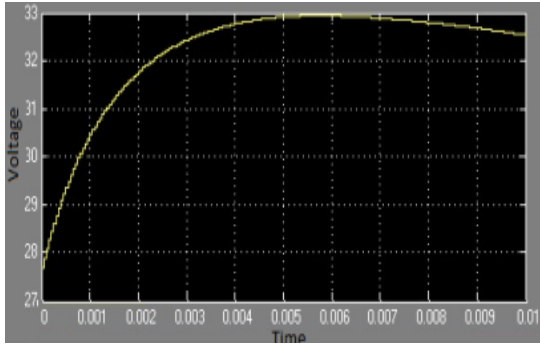

Figure 8: Voltage obtained by the solar panel

The harvested solar energy is interfaced with our hybrid accumulator by the use of a converter placed between the solar panels and the accumulator. The current and voltage signals obtained by the converter are shown in figure 9 and 10.

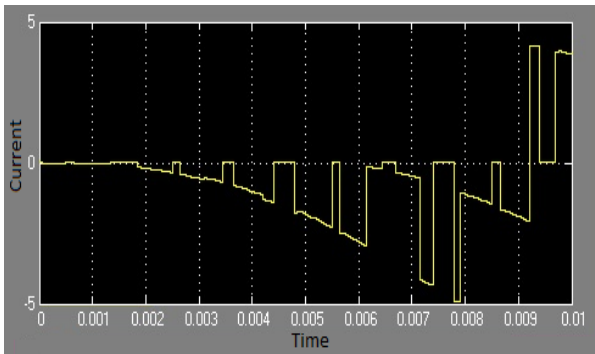

Figure 9: Current obtained by Boost converter

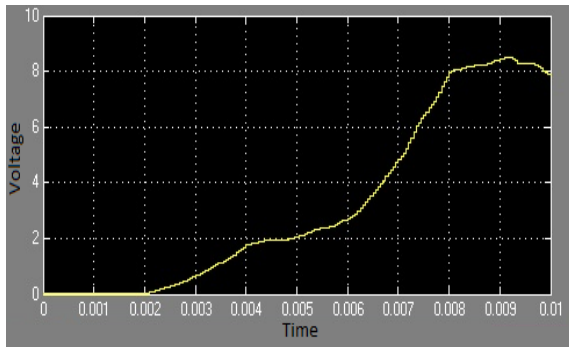

Figure 10: Voltage of Boost converter

The maximum energy from the solar panels is harvested using a voltage regulator which comprises the harvesting unit of our proposed hybrid accumulator design. The voltage obtained by the regulator is shown in figure 11.

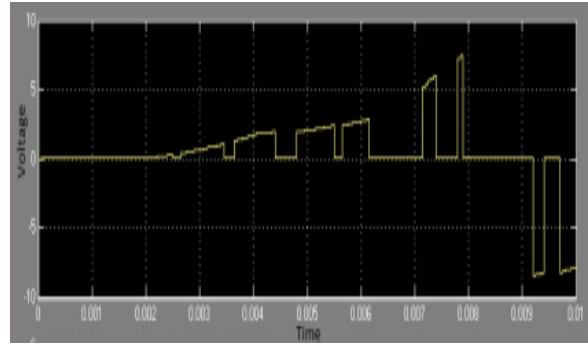

Figure 11: Regulator voltage

The energy from the harvesting unit reaches the storage unit which is the combination of both the battery and an ultra capacitor. The charging mode output of the storage unit is shown in figure 12.

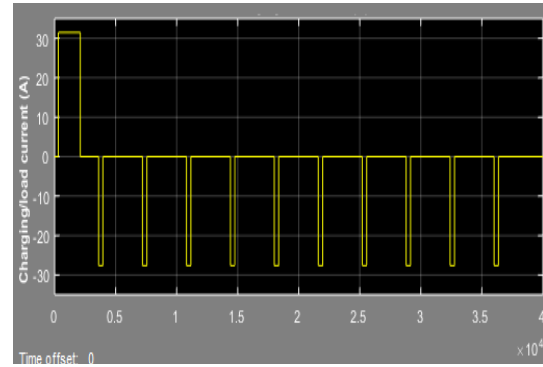

Figure 12: Charging of storage unit

The terminal voltage obtained by the storage unit indicates both the combination of the capacitor and battery voltage. The terminal voltage obtained by the storage unit is shown in figure 13.

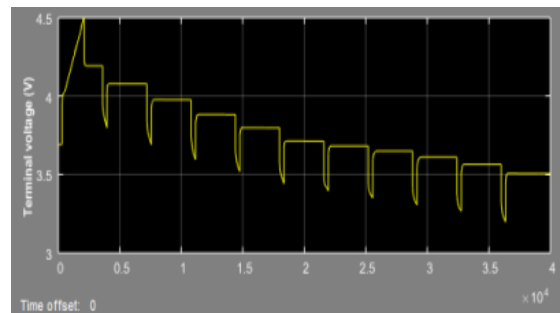

Figure 13: Terminal voltage of the storage unit

SOC is normally used when discussing the current state of a battery in use. An alternate form of the same measure is the depth of discharge (DoD), the inverse of SOC. The state of charge of the battery used in our proposed architecture is shown in figure 14.

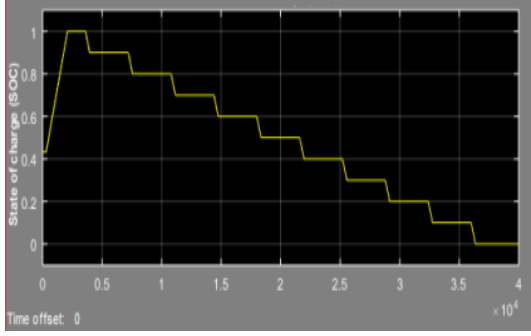

Figure 14:State of charge of the battery

By the above specifications our proposed Simulink model is designed and simulated. The simulation output obtained by our proposed architecture with a solar power as source and an ultracapacitor and battery as a storage unit is given in figure 15.

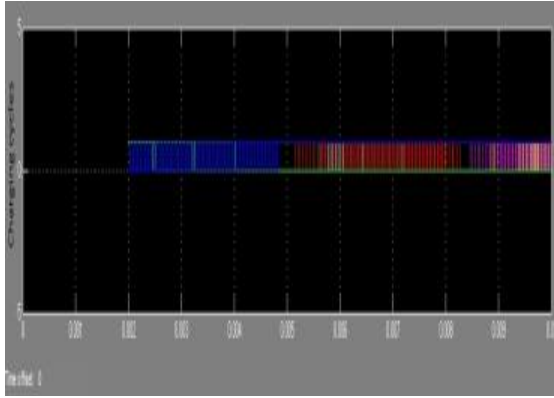

Figure 15: Simulation output of our proposed architecture

From the simulation output it has been seen that by using a capacitor battery combined storage unit with an equivalent number of charge and discharge cycles of 15, average load of 37 mW and the operating time of 88.32%. The power consumption of wireless sensor nodes is 0.25 W with duty cycle of 5 min/h.

4.2 Performance evaluation

The performance of the ultracapacitor in our proposed system can be evaluated, in terms of charge current, energy density, power density and efficiency of the capacitor.

4.2.1 Charge current

The charging current of the capacitor is measured by the following equation is given as:

$$I = Cr \quad (25)$$

where C is the capacitance, r is the scan rate.

4.2.2 Energy density

The energy density of a capacitor can be measured by the following equation given as:

$$\text{Energy density} = \frac{V \times I \times t}{m} \quad (26)$$

Where V is the voltage in volts, I denote electric current in mA, t is the time in seconds, m is the mass in kg.

4.2.3 Power density

The power density of a capacitor can be measured by the following equation is given as:

$$\text{Power density} = \frac{V \times I}{m} \quad (27)$$

4.2.4 Efficiency

The efficiency of a capacitor is the ratio of the discharging capacity of the battery to the charging capacity of the battery which is given by the following equation as

$$\text{Efficiency} = \frac{\text{Discharging capacity}}{\text{Charging capacity}} \quad (28)$$

Table 1 shows the calculated values for our proposed ultracapacitor with some specific scan rates.

Table 1: Calculated values of our proposed ultracapacitor

Input voltage (V)	Capacitance (F/g)	Charge current (mA)	Energy density (Wh/Kg)	Power density (W/Kg)
1	10.1	0.35	0.774	3.68
5	8.35	0.88	0.606	8.51
10	5.77	1.77	0.338	13.3
20	2.58	3.55	0.064	15.2

Table 2 shows the efficiency of our proposed ultracapacitor with different charging and discharging rates.

Table 2 Efficiency of our proposed ultracapacitor

Discharge capacity(C)	Charge capacity(C)	Efficiency (%)
9.02	9.09	99.22
7.60	7.91	96.08
6.23	6.36	97.95
5.38	5.42	99.26
4.51	4.57	98.68
3.18	3.19	99.68

Figure 16 and 17 shows the efficiency of the ultracapacitor for various charging and discharging rate.

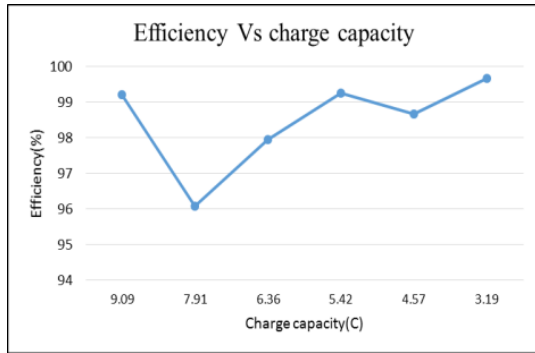

Figure 16: Efficiency Vs charge capacity

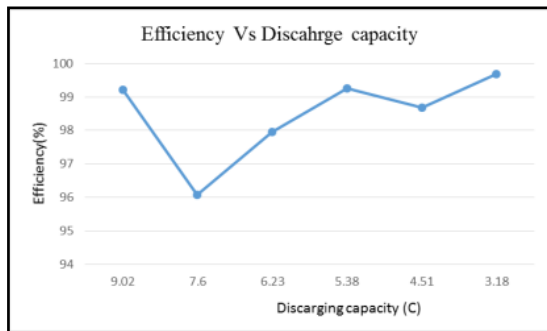

Figure 17: Efficiency vs discharging capacity

Below table 3 shows the comparison of our proposed hybrid energy storage system with the existing energy storage devices.

Table 3: Comparison of proposed energy Storage device with the existing

	Battery	SMES	Flywheel	SC	NaS	Hybrid ESS (proposed)
Efficiency (%)	60-80	95-98	95	95	70	98-99.9
Energy density (Wh/Kg)	20-200	30-100	5-50	50	120	30-200
Power density (W/Kg)	25-1000	10-1000	2000	4000	120	4500
Response time (ms)	30	5	5	5	100	3
Cycle life (time)	200-2000	1000	20000	50000	2000	50000
Cost (\$/kWh)	150-1300	2000	380-2500	250-350	450	100-150

The comparison graph between HESS and other existing energy storage devices regarding the above table is shown in figure 18.

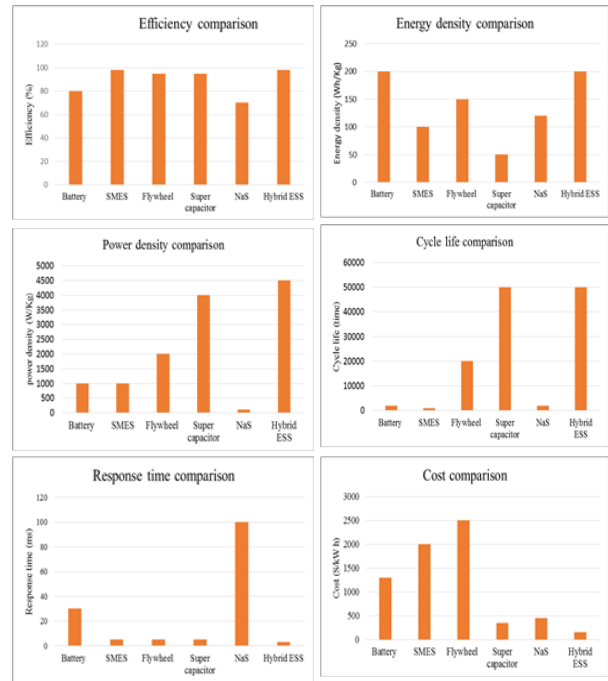

Figure 18: Comparison Results 5(a) Efficiency 5(b) Energy density 5(c) Power density 5(d) Response time 5(e) Cycle life time 5(f) Cost

From the above comparison graph shown in figure 5 we can conclude that the use of HESS in our proposed routing is a better solution to improve the overall performance of the network.

4.3 Discussion

A simulation analysis has been carried out to study the performance of a hybrid energy storage system with ultracapacitor and battery. In this configuration, the UC is connected to the load and interfaced with the battery through a bidirectional dc-dc converter that will control the power fed to the capacitor and also the power delivered from the capacitor. The main purpose of having an energy buffer in the form of UC is that the battery should not be unduly stressed with frequent charging and discharging which will affect the battery life. However, the simulation results shown that, having the capacitor directly across the load without proper control strategy will not provide favourable condition for the battery. The favourable condition is when the battery supplies constant load and the capacitor takes care of load variation such as sudden acceleration and braking action. From the above results and comparisons the efficiency of our proposed method can be evaluated.

5. Conclusion

A trial solar energy harvesting frameworks to power sensor hubs basically makes the wireless sensor organize uncertainly self-managing. The powerful

thickness without more accessibility of solar harvesting framework makes it more favoured than its closest energy harvesting elective. A low-power hybrid accumulator plan proposed in this paper to augment the energy harvesting from solar panels and deal with the repeated power to power the wireless sensor hubs. The general design of the whole work depends on the power converter to expressly make for low power operations, self-sufficiently by the specific way of the solar board and also the battery sort and the power management between li-ion battery and ultracapacitors based on adaptive power organising algorithm. The simulation results and comparison between our proposed and existing method shows, that our hybrid design extracts more power from solar panel and effectively controls it to power the sensor nodes.

References

- [1] kyildiz, I.F., Su, W., Sankarasubramaniam, Y., Cayirci, E. (2002) 'Wireless sensor networks: a survey', *Computer networks*, pp.393-422.
- [2] Amitand, S., Chandrakasan, A. (2001) 'Dynamic power management in wireless sensor networks', *Design & Test of Computers*, pp.62-74.
- [3] Anastasi, G., Conti, M., Francesco, M.D., and Passarella, A. (2007) 'Energy conservation in wireless sensor networks: A survey', *Ad hoc networks*, pp.537-568.
- [4] Min, R., Bhardwaj, M., Cho, S.H., Shih, E., Sinha, A., Wang, A., Chandrakasan, A. (2001) 'Low-power wireless sensor networks', *VLSI Design*, pp.205-210.
- [5] Beatrys, R.L., Nogueira, J.M. and Loureiro, A.A.F. (2003) 'Manna: A management architecture for wireless sensor networks', *Communications Magazine, IEEE*, pp.116-125.
- [6] Vijay, R., et al. (2002) 'Energy-aware wireless microsensor networks', *Signal Processing Magazine*, pp.40-50.
- [7] Rahul, S.C., et al. (2003) 'Data mules: Modeling and analysis of a three-tier architecture for sparse sensor networks', *Ad Hoc Networks*, pp.215-233.
- [8] Yang, Y., Krishnamachari, B., and Prasanna, V.K. (2004) 'Issues in designing middleware for wireless sensor networks', *IEEE Network*, pp.15-21.
- [9] Kevin, K., et al. (2007) 'A component-based architecture for power-efficient media access control in wireless sensor networks', *Embedded networked sensor systems*.
- [10] Jamal, A.K.N., and Kamal, A.E. (2004) 'Routing techniques in wireless sensor networks: a survey', *Wireless communications*, pp.6-28.
- [11] Jennifer, Y., Mukherjee, B., and Ghosal, D. (2008) 'Wireless sensor network survey', *Computer networks*, pp.2292-2330.
- [12] Qin, W., and Yang, W. (2007) 'Energy consumption model for power management in wireless sensor networks, Sensor', *Mesh and Ad Hoc Communications and Networks*.
- [13] Chris, K., and Wagner, D. (2003) 'Secure routing in wireless sensor networks: Attacks and countermeasures', *Ad hoc networks*, pp.293-315.
- [14] Guilar, N.J., Kleeburg, T.J., Chen, A., Yankelevich, D. R., and Amirtharajah, R. (2009) 'Integrated Solar Energy Harvesting and Storage', *IEEE Transactions on Very Large Scale Integration Systems*, Vol.17, No.5, pp.627-637.
- [15] Abbasi, Ahmed, A., and Younis, M. (2007) 'A survey on clustering algorithms for wireless sensor networks', *Computer communications*, pp.2826-2841.
- [16] Yasser, A., et al. (2005) 'Wireless sensor network node with asynchronous architecture and vibration harvesting micro power generator', *Smart objects and ambient intelligence: innovative context-aware services: usages and technologies*.
- [17] Caisheng, W., and Nehrir, M.H. (2008) 'Power management of a stand-alone wind/photovoltaic/fuel cell energy system', *IEEE Transactions on Energy Conversion*, pp.957-967.
- [18] Akyildiz, Ian, F., and Kasimoglu, I.H. (2004) 'Wireless sensor and actor networks: research challenges', *Ad hoc networks*, pp.351-367.
- [19] Alippi, C., and Galperti, C. (2008) 'An Adaptive System for Optimal Solar Energy Harvesting in Wireless Sensor Network Nodes', *IEEE transactions on circuits and systems*, Vol.55, No.6.
- [19] Saggini, S., et al. (2010) 'Supercapacitor-based hybrid storage systems for energy harvesting in wireless sensor networks', *Applied Power Electronics Conference and Exposition (APEC)*, pp.2281-2287.
- [20] Lukicet, S.M., et al. (2006) 'Power management of an ultracapacitor/battery hybrid energy storage system in an HEV', *Vehicle Power and Propulsion Conference*.
- [21] Akinyele, D.O., Rayudu, R.K., Nair, N.K.C. 'Global progress in photovoltaic technologies and the scenario of development of solar panel plant and module performance estimation – Application in Nigeria', *Renewable & Sustainable Energy Reviews*, Vol. 48, pp. 112-139.
- [22] Liu, S., Lu, J., Wu, Q., and Qiu, Q. (2012) 'Harvesting-aware power management for real-time systems with renewable energy', *IEEE Transactions on Very Large Scale Integration (VLSI) Systems*, pp.1473-1486.
- [23] Li, P., Wen, Y., Jia, C., and Li, X. (2011) 'A magnetoelectric composite energy harvester and power management circuit', *IEEE Transactions on Industrial Electronics*, pp.2944-2951.
- [24] Yoash, L., Shmilovitz, D., and Martínez-Salamero, L. (2011) 'A power management strategy for minimization of energy storage reservoirs in wireless systems with energy harvesting', *IEEE Transactions on Circuits and Systems I: Regular Papers*, pp.633-643.

- [25] Suryadevara, N.K., Mukhopadhyay, S.C., Tebje Kelly, S.D. and Gill, S.P.S. (2015) 'WSN-Based Smart Sensors and Actuator for Power Management in Intelligent Buildings', *IEEE/ASME Transactions on Mechatronics*, pp.564-571.
- [26] Melike, E.K., and Mouftah, H.T. (2011) 'Wireless sensor networks for cost-efficient residential energy management in the smart grid', *IEEE Transactions on Smart Grid*, pp.314-325.