

Power Quality Improvement in Wind Integrated Distribution System using Hybrid Fuzzy Genetic Controller

A. Subanth Williams*, Dr. R. Suja Mani Malar¹, Dr. T. Ahilan²

*Assistant Professor, PET Engineering College, Vallioor, Tamil Nadu, India
E-mail: subanthcalls@gmail.com

¹ Professor, DMI College of Engineering, Palanchur, Chennai, Tamil Nadu.

²Principal, St. Joseph College of Engineering, Sriperumbudur, Chennai, Tamil Nadu

Abstract: The distribution systems are transitioning from passive to active with the adaptation of storage, smart-grid, and distribution generation technologies. The reliability of the system can be improved due to the novel controllers, switches, and communication equipment. The common power quality issues are harmonics, signalling voltages, voltage fluctuations, voltage dips, voltage unbalance, power frequency variation, and induced low frequency voltages. These problems can degrade the output power level. To overcome the above problems through the power quality devices like Dynamic voltage restorer (DVR), distribution static compensator (DSTATCOM), and unified power quality conditioner (UPQC). The power quality mitigation technique includes the controller placement and it is named by Hybrid term of fuzzy-genetic controller (FG). Voltage sag, swell, and harmonics, such kind of problems have been analysed in this paper. The results are compared with the existing controllers. The proposed results are load voltage, injected voltage, and generated voltages are taken out. The performance of power quality is analysed through the multi compensating devices, and it is implemented in MMATLAB/SIMULINK. Thus the proposed system can yield the better results instead of the harmonic which is appeared in DVR, DSTATCOM, and UPQC are 0.008231%, 0.0831%, and 0.004308% respectively.

Keywords:Dynamic Voltage Restorer; Distribution static compensator; Fuzzy Genetic Algorithm; Voltage Sag/Swell; Power Quality Improvement; Harmonic Reduction.

1. Introduction

The electricity is the essential need of today's automatic and innovative world. The electric power distribution system supplies electricity, the ultimate aim of the distribution system is to satisfy the power requirement of the consumers for their changing needs [1-2]. The supply interruption is caused ultimately by the ever increasing needs of customers. Hence the aim of perfect power system is to satisfy the customer needs up to their requirement settlement for long duration [3]. This drawback is overcoming with the ultimate aid of renewable energy resources integrated with power system, which enhances the efficiency of supply to the needed consumer. The commonly used renewable energy resources are geothermal, biomass, hydropower, solar resource, wind power and tidal power [4]. The solar and wind power are the recent trend in distribution system [5-7].

The simple way of maintenance and reduced amount of accession makes the wind resource system most wanted renewable source [8]. The challenges in terms of technical needs associated with the integration of renewable resources. The major issues technically related with this integration are instability in voltage, power factor mislead, harmonic distortion and so on [9]. The power quality is

considered in all areas such as wind generation, transmission, and distribution of power to needed customer.

The proper control scheme is adapted for the integration of wind power system for satisfactory and protective operation of power system. The error is measured at the common coupling point and which is eliminated through a suitable compensator device, which can technically manage the power level connect with commercial wind turbine [10]. The compensator device used for power quality enhancement is the Flexible Alternating Current Transmission Systems or flexible alternating current transmission system devices [11- 12].

The reactive power compensation and harmonic reduction are established with Distributed Static Compensator (DSTATCOM) device assistance [13]. The voltage regulation, swell and sag mitigation are the common problems reduced with the help of Dynamic Voltage Restorer (DVR) [14]. Unified Power Quality Conditioner (UPQC) designed by combination of series and shunt active filter. It provides the power quality improvement by mitigating voltage regulation problems, harmonics and power related issues [15].

The power quality mitigation is performed by compensation device with proper controlling techniques. The compensation device activeness based on control

signal. The conventional controllers are used to generate the control signal. The drawback in conventional controller is, instability in withstand the transient. Recent trends uses artificial intelligence technique such as artificial neural network, fuzzy control and many optimization techniques are used as controller.

In the proposed work there are three different compensation devices named DVR, DSTATCOM and UPQC are used for power quality improvement in wind power distribution system. The devices are controlled by FGA controller. The performance of the proposed three devices is investigated and proves UPQC yields better compensation by means of better controller. The layout of the work is organized as below, in section 1, the historical details of power quality, and the devices are mentioned, in section 2, the recent works are described, the contribution of the work is organized in section 3, the problem formulation is defined in section 4, the proposed methodology has been evolved in section 5, and in 6 the results are appeared.

2. Related works

The works recently developed with the objective of power quality improvement and it is given below,

Raj Kumar *et al.* [16] had developed a control algorithm based on Dual Tree-Complex Wavelet Transform (DT-CWT) used for enhanced the power quality in distribution static compensator. Harmonics and unbalancing of phase load currents was decreased by using this algorithm. The reference active power elements were calculated by excerpt the particular line frequency element. Different load situations were presented in the simulation performance of DSTATCOM.

Karthikrajan Senthilnathan *et al.* [17] had discussed the power quality disturbance mitigation in three feeder system. The mitigation was obtained through the unified power quality conditioner designed with multilevel converter. The controlling of converter was given by the Levenberg-Marquardt back-propagation algorithm based artificial neural network. The power quality issues were analysed. The issues considered are voltage instability and distortion problems.

Bhim Singh *et al.* [18] had implemented a three-phase Distribution Static Compensator used for enhanced the power quality by utilizing Self Tuning Filter (STF) and it was based on Instantaneous Reactive Power Theory (IRPT). The loads were balanced at the Point of Common Coupling and harmonics were removed by using this technique. The overshoot and undershoot of Proportional-Integral was reduced and the response was enhanced by using an adaptive fuzzy logic controller. Digital Signal Processor was utilized in the real time execution of DSTATCOM.

The dynamic voltage restorer (DVR) was used in the enhancement of voltage quality and sensitive loads from voltage sags. But, the cost and size of dc link energy storing structure was increased by using the high active power in the compensating device. Abdul Mannan Rauf *et al.* [19] had developed a sag compensation technique used for diminished the phase jump in the load voltage. The DVR sag support time was increased and dc link capacitor size was reduced by using this technique.

For the power quality improvement the FACTS devices usage is a most wanted thing. The usage of these devices it is necessary to identify the location and size. It was discussed in [20] by A. RezaeeJordehi *et al.* by using brainstorm optimization algorithm to find optimal location and setting of FACTS device. The compensator used here were static var compensator and thyristors series controlled device. The power controller device allocation problem was formulated as multi objective problem whose objectives were voltage profile enhancement, minimization of overload and minimization of loss.

3. Contribution

- Modelling of multi type compensating devices such as dynamic voltage restorer (DVR), unified power quality conditioner (UPQC), and Distributed Static Compensator (DSTATCOM).
- Avoid the problems of voltage sag, swell, and harmonics.
- Design the novel fuzzy-genetic controller (FG) to avoid those kind of problems.

4. Problem formulation

Now a days power quality issues are of most concern due to the widespread usage of electronic equipment such as controllers, variable loads. The loads are the victim of causing the power quality issues. Due to its nonlinearity, the voltage waveform is affected by some harmonics presence. The major problems in this paper is mentioned in abstract itself and the corresponding equations are mentioned below, based on this the problems are rectified.

Constraints

The constraints which affect the power quality is mentioned below,

- Voltage Sag
- Voltage Swell
- Harmonics

Voltage sag:

One of the most significant PQ interruptions is voltage sag, from the minimal voltage level the value is unexpectedly decreased this is generally known as voltage sag. The consistency of power distribution system is affected with voltage deviation.

Voltage Swell:

The sudden increase in minimal voltage to an unexpected magnitude level is point out as voltage swell. The fault arise in the distribution lines and the unexpected device faults are produces the voltage swell.

Harmonics:

The values of voltage and current is distorted because of the unwanted disturbances in the power distribution system. The total harmonic distortion (THD) is calculated as:

$$THD_v = \frac{\sqrt{v_{2,rms}^2 + v_{3,rms}^2 + v_{4,rms}^2 + \dots + v_{n,rms}^2}}{v_{1,rms}} * 100\% \quad (1)$$

The THD diminish the efficiency of load voltage at the point of common coupling.

4.1 Dynamic Voltage Restorer (DVR)

The device coupled in series with the supply line voltage is known as DVR. It is regarded as controlled voltage deviations on load side. The voltage injection of main phase with respect to load current denotes the efficiency of active power transfer [21].

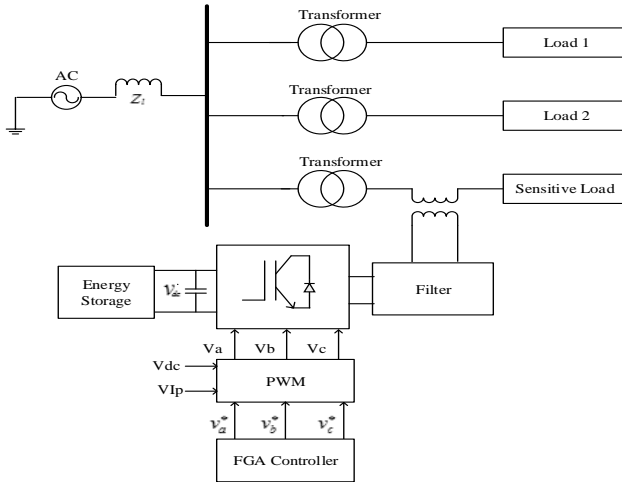

Fig 1: Configuration of DVR

Fig 1, demonstrate the model of power system with DVR connection. The fault is measured at the point of common coupling. The DVR connected in this model is load side connected shunt converter. With this composition the input voltage to the shunt converter is controlled and the DC link voltage can be sustained constant by inserting sufficient voltage and it is mentioned in equatrion (2).

$$v_{dc} = v_{load} = \alpha + v_{dvr} \quad (2)$$

$$v_{shunt} = 1 \text{ and } v_{series} = 1 - \alpha \quad (3)$$

The DVR can be functioned with variable dc-link voltage. The stored energy is related to the square of the rated dc-link voltage and it is in equation (4).

$$E_{st} = \frac{1}{2} c_{dc} v_{dc}^2 \quad (4)$$

The system impedance (z_{th}) depends on the fault level of load bus. During the system voltage (v_{th}) drops, the DVR insert a series voltage (v_{dvr}) via injection transformer. Therefore the desired load voltage magnitude v_l is maintained. The series injected voltage of DVR is represented as,

$$v_{dvr} = v_l + z_{th} i_l - v_{th} \quad (5)$$

In equation (5), v_l - desired load voltage magnitude; z_{th} - load impedance; i_l - load current; v_{th} - system voltage during fault condition. The DVR complex power injection can be represented as,

$$S_{dvr} = v_{dvr} i_l^* \quad (6)$$

The load connected to the distribution system decides the compensation technique of dynamic voltage restorer. The DVR injected voltage in the pre-sag compensation mode can be described as below,

$$v_{dvr} = \sqrt{(v_l^2 + v_s^2 - 2v_l v_s \cos \delta)} \quad (7)$$

The required injection voltage θ_{inj} is described based on the below relation.

$$\theta_{inj} = \tan^{-1} \frac{v_s \sin \theta}{v_s \cos \theta - v_l} \quad (8)$$

The phase angles of the pre-sag and load voltage are varied but the most significant criteria for power quality is the constant magnitude of load voltage satisfaction.

$$v_l = v_{l \text{ pre}fault} \quad (9)$$

4.2 Distributed Static Compensator (DSTATCOM)

The distributed static compensator is power quality enhancement equipment which consists of VSC and a DC link capacitor connected in shunt which is able to generating and absorbing reactive power. The below figure is the representation of distributed static compensator connected with distribution system.

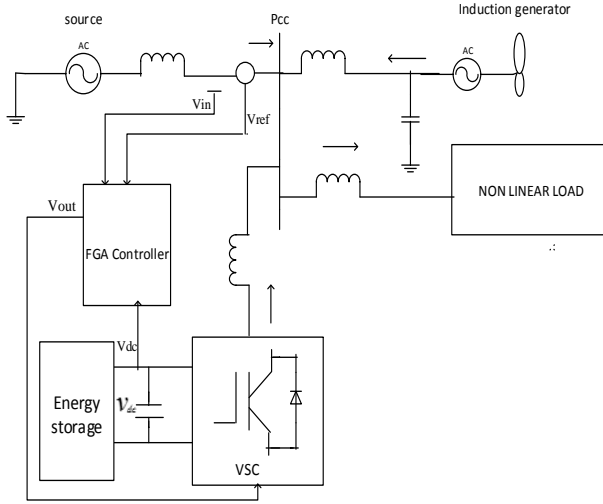

Fig 2 Configuration of DSTATCOM

4.2.1. Filtering of active harmonics

The current which flow in the distribution system is measured at segregate into fundamental and harmonic component [22]. DSTATCOM inserts current into the system which removes the harmonic element.

4.2.2. Compensator (Reactive power)

In the two different operation modes the distributed static compensator inserts step to reduced reactive power. This injection provides reactive power compensation.

4.2.3. Active power transfer

Energy storage devices connected to the dc link capacitor allow energy to be transferred in to the network. The output current will correct the voltage sags by modify the voltage drop across the system impedance.

$$i_o = i_l - i_s = i_l - \frac{v_{th} - v_l}{z_{th}} \quad (10)$$

$$i_o \angle \mu = i_l \angle (-\theta) - \frac{v_{th}}{z_{th}} \angle (\delta - \beta) + \frac{v_l}{z_{th}} \angle (-\beta) \quad (11)$$

4.3. Unified Power Quality Conditioner (UPQC)

Unified power quality conditioner is the combined form of shunt and series compensator connected by means of common DC link capacitor [23].

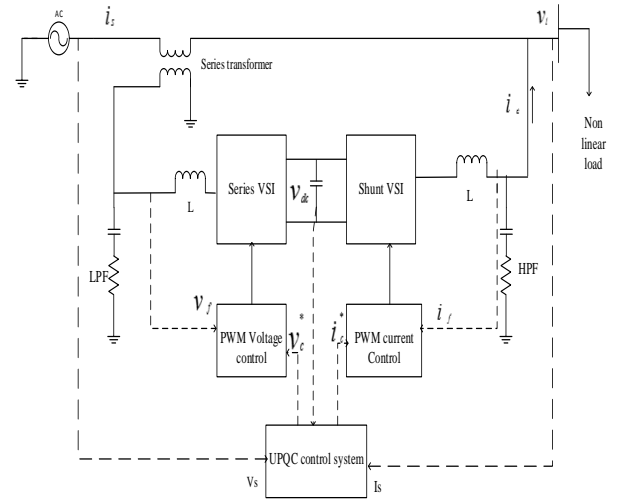

Fig 3 Configuration of UPQC

4.3.1. Conversion process

The inverter circuits convert AC to DC power .The most common types of inverter are voltage and current source inverter. The proposed model utilize the voltage source inverter.

4.3.2. Filtering process

The harmonics can be eliminating by using inverter side and line side filter. Inverter side filter prevents the flow of harmonic current to penetrate through injection transformer. The difficulties of inverter side filter is, it cause voltage drop and phase angle shift in output of inverter. In line side filtering harmonic current penetrates through injection transformer but voltage drop and phase shift does not interrupt the system. The system utilize inverter side filtering for quality efficiency.

4.3.3. Injection unit

The series voltage source inverter of UPQC is in standby mode for most of time and conduction loss is high during operation. During this mode the series injection transformer act as secondary winding shorted current transformer using bypass switches delivering utility power to the load.

4.3.4. Control unit

The control unit is the head of UPQC system. The control unit utilized in the system is series and shunt inverter control. The series inverter control contains sag/swell detection, voltage reference generation, voltage injection strategies, and gate signal generation techniques. The shunt inverter control includes current reference generation, method of generating gate signal and capacitor voltage control.

4.3.5. Mathematical modelling of UPQC

The unified power quality controller possesses two voltage source converters they are shunt and series converter. In order to remove the harmonics commenced by non-linear load the shunt inverter injects the current,

$$i_{sh}(dt) = i_s^*(dt) - i_l(dt) \quad (12)$$

Where $i_{sh}(dt), i_s^*(dt), i_l(dt)$ represents shunt voltage source converter current, reference supply current, and load current respectively.

The series inverter of UPQC is working in voltage control mode as it supplies and injects voltage in series with line to realize a sinusoidal, pure voltage at the load terminal. The injected voltage by series is depicted as:

$$v_{sr}(dt) = v_l^*(dt) - v_s(dt) \quad (13)$$

Where $v_{sr}(dt), v_l^*(dt), v_s(dt)$ represents the series inverter injected voltage, reference load voltage and actual supply voltage respectively. The functionality of UPQC is to mitigate voltage and current related problems.

5. Proposed control strategy

The controllers such as DVR, UPQC, and DSTATCOM are developed to generate control signal and it is converted into pulses through the PWM generators, for that reason several controllers are proposed. Then the control signal to be tuned to the gate signal of the inverter. The input of the controllers are taken as error of voltage or current, here the reference voltage is taken as v_{lp} , and the actual voltage to be v_{dc} , The optimum signals are generated randomly with the hybrid FG controllers. The controller uses hybrid fuzzy-genetic to select the optimum signal randomly. The optimization process is executing in the controller and the reference voltage is attained as output from controller. The compensation signal is fed to the power system for mitigating power quality difficulties.

To enhance the power supply quality the integration of renewable energy resources such as wind source is essential in today's technical world, which stimulates the PQ interruptions in the power system. The ultimate objective of this proposed literature is to diminish the power quality disturbances. Dynamic voltage restorer, distributed static compensator and unified power quality conditioner are the compensation devices taken for power quality improvement. In order to attain the power quality efficiency the controlling unit Hybrid FGA (Fuzzy Genetic Algorithm) is utilized.

The proposed work possess power grid which is interrelated with Doubly Fed Induction Generator based wind turbine which synchronised in term of frequency and voltage. For power quality enhancement the compensators are designed and control strategy is done by fuzzy genetic algorithm. By means of this algorithm the reference voltage for series inverter and reference current for shunt inverter is achieved, which is utilized to mitigate both supply and load side voltage. The effectiveness of the proposed system with fuzzy genetic algorithm is correlated with normal fuzzy logic controller.

5.1. Fuzzy-Genetic controller[25, 26]

The controller system utilized in this model is combined fuzzy genetic algorithm. The hybridisation is done in the decision making part of fuzzy logic. There the decision making is evaluated through the genetic optimization. The objective function of genetic algorithm is to select the minimized error value for optimization of fuzzy controller.

Step 1: Input to controller

The changes between load voltage and reference voltage (error in voltage) and error rate (the rate of change of error in voltage) is used as input to fuzzy logic controller error. The error rate is described as,

$$v_s - v_{sref} = v_c^* \quad (14)$$

$$i_s - i_{sref} = i_c^* \quad (15)$$

$$ROE = \frac{d}{dt}(v_{cn}^*) - \frac{d}{dt}(v_{c(n-1)}^*) \quad (16)$$

Step 2: Fuzzification of inputs

In the course of fuzzification the error and error rate are represented in the form of linguistic variables. The membership function utilized here is the triangular one.

Step 3: Decision making by genetic algorithm

Genetic algorithm is a global heuristic algorithm. Genetic algorithm is one type of evolutionary algorithm based on Darwin's theory that is "the strongest species that survives" affected the subsistence of an organism. The genetic algorithm holds three processes 1) Reproduction, 2) Crossover, 3) Mutation. In this paper the genetic algorithm is utilized for the selection of minimized error signal which fed for Defuzzification.

Step 4: Initialization

The first step of the genetic algorithm is initialization. Here the parameters are going to be initialized are number of chromosomes in the population and genes. The genes in every chromosome hold some values based on the objective function.

Step 5: Evaluation

The objective function is evaluated in the second step. Eqn. (17) describes the objective function,

$$objective = optimum\ of\ Error \quad (17)$$

The objective function value for each chromosome is estimated. If the best objective is attained in the evaluation process is stopped otherwise the process is continued with selection process.

Step 6: Selection

Generally in the selection of the best chromosome the roulette wheel technique is utilized. The chromosome with the higher probability has been selected for the next

generation. The fitness of the chromosome is finding out by the below,

$$fitness = \frac{1}{1 + objective} \quad (18)$$

After the estimation of fitness for each chromosome the values are summed. From the summed value of fitness the probability is calculated.

Step 7: Crossover

The process of generation of new chromosome is generally described as crossover. Crossover doesn't always occur. The probability of crossover occurring is usually about 60% to 70%.

Step 8: Mutation

After the process of selection and crossover the new chromosomes are produced. These individuals are not exactly same is determined by the mutation. The number of chromosomes is undergone crossover and mutation is generally controlled by crossover and mutation rate. After many iterations the chromosomes are converges to a certain value this is the minimised error value.

Step 9: Defuzzification

Defuzzification is the way of changing the controller output in linguistic labels represented by fuzzy set to real control signals. By using the genetic algorithm the optimized control signal is selected randomly for defuzzification. The error voltage and error rate concern in order to generate the control signal.

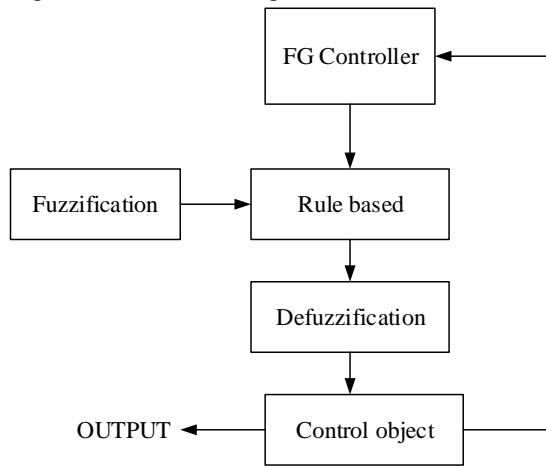

Fig 4: FUZZY-GENETIC Controller

6. Result and discussion

The power quality enhancement is taken as the main part of the work. The design parameters of the proposed system are described below,

Table 1: Design Parameters

Parameters	Values used in simulation
Series transformer Ratio	- 1:1
Shunt APF	Filter Inductance L=6mH Filter Capacitance C=20uF
DC link capacitance	2200uF
Inverter	IGBT based, arms, 6 pulse carrier frequency =10000Hz

6.1. Existing System

The power quality enhancement is verified by using conventional PI controller. The simulation diagram comprises of UPQC with PI controller for power system compensation. The performance of this system with only PI controller is shown the figure 5.

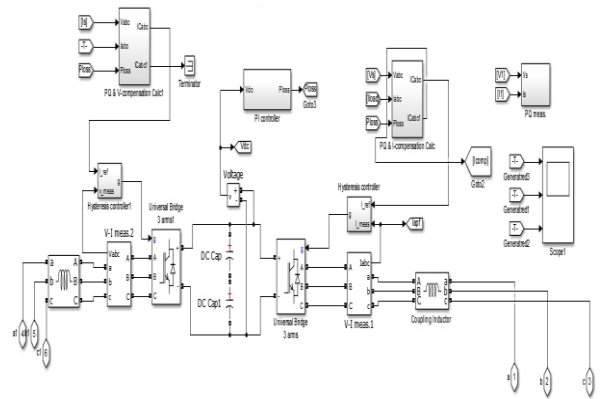

Fig 5: Simulink model for UPQC with PI controller

The generated voltage by

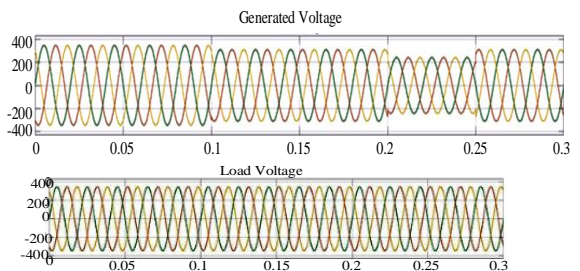

Fig 6: Output waveform for UPQC with PI controller

The simulation results showed the mitigation of voltage sag and swell to a considerable level. The total harmonic distortion obtained by utilizing the conventional PI controller is 0.004535%.

6.2. DSTATCOM and DVR based Compensation

The tuning of DVR and DSTATCOM is finished by FGA algorithm. From the successive figures the

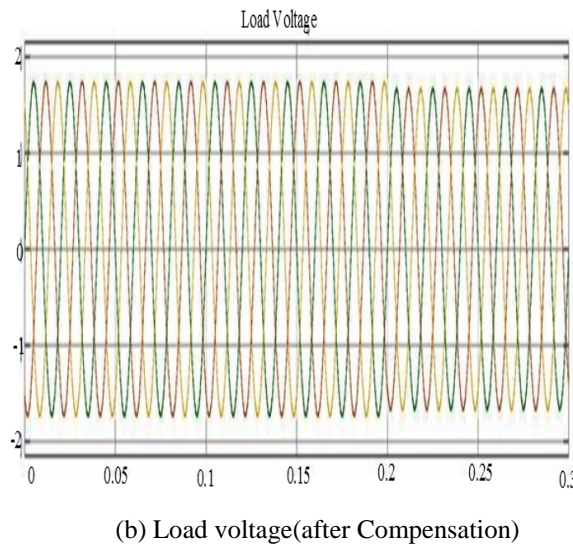
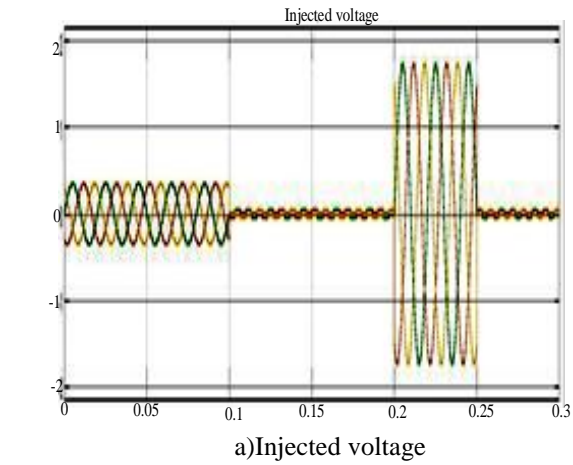

Fig 7: Performance of DSTATCOM

Fig 7, pinpoints the performance of DSTATCOM. During the occurrence of voltage distortion the DSTATCOM injection voltage is fed to the system for compensation. The generated voltage possess voltage swell at time period of 0 to 0.1 sec. The injection of DSTATCOM voltage during the same time period mitigates the voltage swell. The final load output voltage is presented at the Fig 8 (b).

performance of the DVR and DSTATCOM for power quality improvement is analysed.

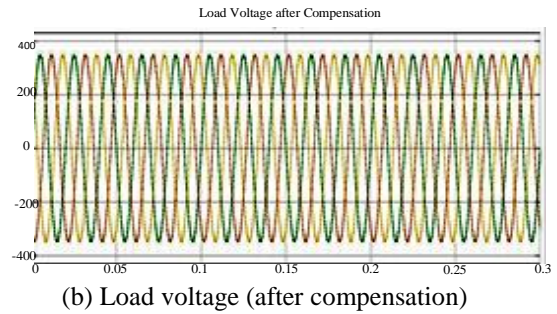
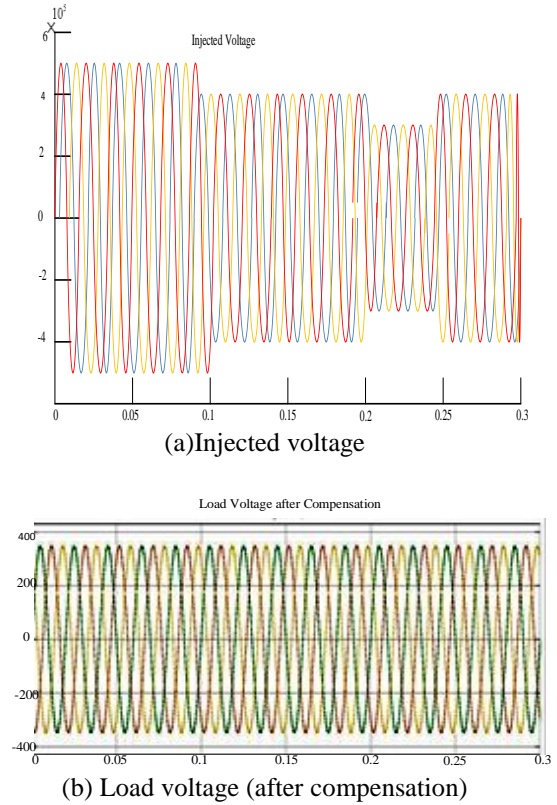

Fig 8: Performance of DVR

From Fig 8, the performance of DVR is evaluated. The injection voltage is bolstering to the power system in order to compensate the voltage deterioration.

6.3 Proposed System

The proposed technique significantly diminish the power quality problems in the wind integrated distribution system. The performance enrichment in the proposed system is achieved through the defined controller system named fuzzy hybridised with genetic optimization algorithm named FG controller.

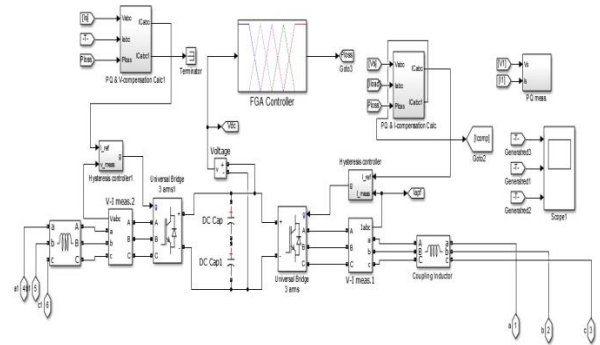

Fig 9:Simulation model for UPQC with FG controller

Fig 9, indicates the simulink model for UPQC with FG controller. The system is associated with wind turbine. The output waveforms of simulation is indicated below.

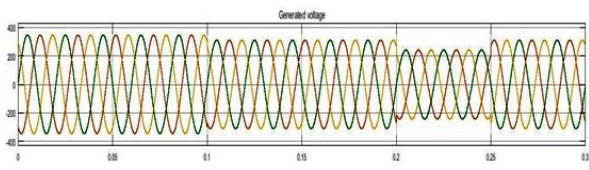

Fig 10: Generated voltage

Fig 10, indicates the generated signal of power system. The generated signal consists of voltage sag, swell and interruption. The voltage sag occurs in the time period 0.2 to 0.25 sec. The voltage swell occurs from 0 to 0.1sec. The voltage interruption occurs at the time interval of 0.2 sec.

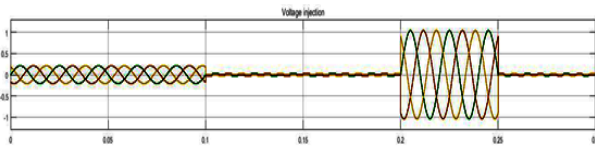

Fig 11: Injected voltage UPQC

Fig 11, reveals the injection voltage of UPQC. Based on voltage sag and swell condition, the UPQC injection voltage is used in the power system for compensation.

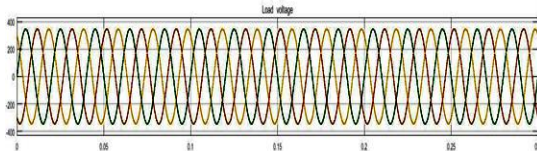

Fig 12: Load voltage after compensation (UPQC)

The above fig 12, simulation results indicate the compensated load voltage after using the compensation device UPQC. The power quality enhancement devices perform the mitigation in effective way. Among the three, UPQC provides an effective mitigation and makes the power system more reliable.

Table 2: Performance Comparison

System	Load current THD	
	PI controller	FG controller
DSTATCOM	0.4692%	0.008231%
DVR	0.08748%	0.0831%
UPQC	0.004535%	0.004308%

Table 2, shows the comparison table for using UPQC using PI controller and FG controller. The table reveals that the UPQC with conventional controller has total harmonic distortion of 0.004535%.The proposed system with FG controller eliminate the total harmonic distortion up to considerable level. The total harmonic distortion obtained by using the FG controller is 0.004308%.

7. Conclusion

The power quality is the important aspect of a power distribution system. It is varied because of the integration of renewable energy resources into the distribution system. This paper discusses the power quality enhancement in a wind integrated distribution system. The hindrances of PQ are voltage sag, voltage swell and harmonics are discussed in the paper. The elimination of these issues is done by using the compensating devices DVR, DSTATCOM and UPQC with hybrid fuzzy genetic algorithm controller. In the result and discussion part the separate performances of compensators are analysed. Among the analysis the Hybrid FGA tuned UPQC mitigates power quality issues significantly. The performance of the three compensation devices are evaluated and compared with an existing system controlled by a PI controller. In addition, the harmonics are mitigated in a superior way by keeping THD level within acceptable bounds. Thus the proposed Fuzzy Genetic Algorithm controlled UPQC is successfully proven as efficient device through its outstanding performance for improving PQ in a wind source added system.

References

- [1]. M.K. Gray, W.G. Morsi. "Power quality assessment in distribution systems embedded with plug-in hybrid and battery electric vehicles". *IEEE Transactions on Power Systems*, vol.30, pp.663-671,2015.
- [2]. P.S. Georgilakis, N.D. Hatziargyriou. "A review of power distribution planning in the modern power systems era, Models, methods and future research". *Electric Power Systems Research*, vol.121 ,pp.89-100, 2015.
- [3]. O.P. Mahela, A.G. Shaik, N.Gupta, "A critical review of detection and classification of power quality events". *Renewable and Sustainable Energy Reviews* vol.41, pp.495-505, 2015.
- [4]. S.R.Dubey. "Energy Crisis in India: A Commentary on India's Electricity Sector", *Partridge Publishing*, 2015.
- [5]. A.N. Esen, Z.Duzgit, A.Ö. Toy, M.E. Günay, "An Overview of Energy Technologies for a Sustainable Future", *In Energy Systems and Management*, pp1-16, 2015.

- [6]. P.Gevorkian, "Large-scale Solar Power Systems: Construction and Economics", *Cambridge University Press* 2012.
- [7]. V.C. Nelson, K.L. Starcher, "Introduction to renewable energy", *CRC press*, 2015.
- [8]. S.Sumathi, L.Ashok Kumar, P.Surekha. "Solar PV and Wind Energy Conversion Systems: An Introduction to Theory, Modeling with MATLAB/SIMULINK, and the Role of Soft Computing Techniques", *Springer* 2015.
- [9]. S.L.B Pereira. "Strategic planning of electricity systems", *Integrating renewable energies*.
- [10]. V.Yuvaraj, E.Pratheep Raj, A.Mowlidharan, L.Thirugnanamoorthy. "Power quality improvement for grid connected wind energy system using FACTS device". In *Proceedings of IEEE Joint 3rd Int'l Workshop on Nonlinear Dynamics and Synchronization & 16th International Symposium on Theoretical Electrical Engineering* vol.3, pp.1-7, 2011.
- [11]. M.A. Saqib, A.Z. Saleem. "Power-quality issues and the need for reactive-power compensation in the grid integration of wind power", *Renewable and Sustainable Energy Reviews*, vol.43, pp. 51-64, 2015.
- [12]. P.K. Mani, K.S. Naidu, "Improvement of Power Quality using custom power devices", *ARPJ Journal of Engineering and Applied Sciences*, vol.10, pp. 3555-3560, 2015.
- [13]. K.Murugesan, R.Muthu, S.Vijayenthira, J.B.Mervin. "Prototype hardware realization of the DSTATCOM for reactive power compensation", *International Journal of Electrical Power & Energy Systems* vol.65, pp.169-178, 2015.
- [14]. G.S. Sarode, D.P.J. Shah, D.R. Saxena. "Overview of Interline Dynamic Voltage Restorer for Power Quality Improvement", *Australian Journal of Information Technology and Communication*, vol.2, pp.16-20, 2015.
- [15]. P.K. Mani, D.K.S. Naidu. "Unified Power Quality Conditioner (UPQC) with Hysteresis Controller for Power Quality Improvement in Distribution System", *International Journal of Applied Engineering Research* vol.10, pp. 9124-9130, 2015.
- [16]. R.Kumar, B.Singh, D.T. Shahani, C.Jain, "Dual-Tree Complex Wavelet Transform Based Control Algorithm for Power Quality Improvement in a Distribution System", *IEEE Transactions on Industrial Electronics*.
- [17]. K.Senthilnathan, K.I. Annapoorani. "Artificial Neural Network Control Strategy for Multi-Converter Unified Power Quality Conditioner for Power Quality Improvements in 3-Feeder System", *Artificial Intelligence and Evolutionary Computations in Engineering Systems*, pp.1105-1111, 2016.
- [18]. B.Singh, S.K. Dube, S.R. Arya. "An improved control algorithm of DSTATCOM for power quality improvement", *International Journal of Electrical Power & Energy Systems* vol.64, pp 493-504, 2015.
- [19]. A.M. Rauf, V.Khadkikar, "An enhanced voltage sag compensation scheme for dynamic voltage restorer", *IEEE Transactions on Industrial Electronics*, vol.62, pp.2683-2692, 2015.
- [20]. A.R.Jordehi, "Brainstorm optimisation algorithm (BSOA): An efficient algorithm for finding optimal location and setting of FACTS devices in electric power systems", *International Journal of Electrical Power & Energy Systems*, vol.69, pp.48-57, 2015.
- [21]. Y.Prakash, S.Sankar. "Power quality improvement using DVR in power system". *IEEE Power and Energy Systems Conference, Towards Sustainable Energy* pp.1-6, 2014.
- [22]. B.Singh, S.R. Arya. "Back-propagation control algorithm for power quality improvement using DSTATCOM". *IEEE transactions on industrial electronics*, vol. 61, pp.1204-1212, 2014.
- [23]. O.P. Mahela, A.G. Shai. "Topological aspects of power quality improvement techniques: A comprehensive overview", *Renewable and Sustainable Energy Reviews*, vol.58, pp.1129-1142, 2016.
- [24]. R.Bhavani, N.R. Prabha, C.Kanmani, "Fuzzy controlled UPQC for power quality enhancement in a DFIG based grid connected wind power system". *IEEE International Conference on Circuit, Power and Computing Technologies (ICCPCT)*, pp.1-7, 2015.
- [25]. S.M. Odeh, A.M. Mora, M.N. Moreno, J.J. Merelo. "A hybrid fuzzy genetic algorithm for an adaptive traffic signal system", *Advances in Fuzzy Systems*, vol.11, pp.1, 2014.
- [26]. C.Changdar, G.S. Mahapatra, R.K. Pal. "An improved genetic algorithm based approach to solve constrained knapsack problem in fuzzy environment", *Expert Systems with Applications* vol.42, pp 2276-2286, 2015.