

Induction Motor Stator Inter-turn Short Circuit Fault Detection in Accordance with Line Current Sequence Components Using Artificial Neural Network

Gayatri Devi R
Research Scholar,
Hindustan Institute of Technology and Science.
Assistant Professor, Dept. of EEE
KCG College of Technology
Chennai, India.
gayatri Devi.eee@kcgcollege.com

Dr. S. Sekar
Professor,
Dept. of EEE,
Hindustan Institute of Technology and Science
Chennai, India.
ssekar.pt@hindustanuniv.ac.in

Abstract — The intention of fault detection is to detect the fault at beginning stage and shutoff the machine immediately to avoid motor failure due to the large fault current. In this work, an online fault diagnosis of stator inter- turn fault of three phase induction motor based on the concept of symmetrical components is presented. Mathematical model of induction motor with turn fault is developed to interpret machine performance under fault. Using this Simulink model of three phase induction motor with stator inter turn fault is created for extraction of sequence components of current and voltage. The negative sequence current can provide a decisive and rapid monitoring technique to detect stator inter turn short circuit fault of induction motor. The per unit change in negative sequence current with positive sequence current is the main fault indicator which is imported to neural network architecture. The output of the feed forward back propagation neural network classifies the short circuit fault level of the stator winding.

Keywords — Stator winding, Induction motor, Simulink, Inter-turn short circuiting, per unit change in sequence components, Artificial neural network.

I. INTRODUCTION

INDUCTION MOTORS overpower the field of electro-mechanical energy conversion. Its reliability, low cost and high performance make them the most popular alternating current motors. The motors have the flexibility of application fields; from household appliances to high power industrial motors. In recent years, the problems of failure in large induction motors have become more significant. For the fault diagnosis problem, it is important to detect if the system has a fault and find its origin. [1]. If motor failure is unattended at early stage, it may become detrimental and damage the motor. This will cause industry production cessation.

In [2] many fault situations are mentioned. One among them is a case in which a disintegrated rotor bar had erupted from the slot and it created damage in stator winding. Faults in

induction motor can be either mechanical or electrical. Major mechanical faults are bearing fault [3-5] and broken rotor bar [6-10]. Electrical fault is influenced by power quality that supplied by AC grid, frequency variations and voltage disturbances. Another fault is short circuits stator winding [3,11-13]. Among total fault occurring in induction motor, more than one third is that of stator winding fault. Short circuit in stator winding takes very short time to evolve and can totally damage motor. Normally, the inter turn short circuit fault progresses to an inter coil fault, phase winding fault, single line ground fault, resulting in breakdown of the motor. Detection of winding fault in the starting stage increases the practicability of repairing the machine by rewinding it or, in large motors, displacing short circuited coils.

Traditional ways of fault monitoring were based on leakage flux sensing [15], partial discharge [16], harmonics in stator current and voltage [17] etc. Ensuing studies however, demonstrated that many of these traditional techniques are liable to oddity due to supply voltage distortions [18], built in machine asymmetries [19], coincidental effects of stator and rotor faults, etc. Motor current signature analysis (MCSA) is an important technique adopted for condition monitoring. Induction motor faults like bearing problems, broken rotor bar, eccentricity abnormalities, stator winding faults cause variation in amplitude and frequency of motor current signature [3-5,6-9,11-13]. Motor current signature analysis can not identify stator inter-turn fault when it coincides with other faults.

Insulation testing method, an off-line method is traditionally used to find out and detect the various faults like turn to turn, in stator winding but it is inconvenient to test them frequently. The past of error detection and error segregation began with utilizing of electromechanical relays [14] to defend the IM the motor from failure due to various faults. But these electromechanical relays require periodic maintenance, slow in operation and consume power. The establishment of semiconductor technology had a good impact on the protection field, solid state relays replaced the electromechanical relays because of their faster operating speed, less power consumption and more reliability. Evolution of microprocessor technology in

early 1970's authorized their application in the protective relays. In these relays software programming is inbuilt to implement the protection logic.

Breakthrough in signal conditioning techniques and advances in computer software has taken machine fault detection to newer heights. Most of the demonstrated works in stator winding fault detection are from frequency analysis domain. Signal transforming methods like Fast Fourier transform (FFT), S-transform, Short time Fourier transform (STFT), wavelet transform, and Hilbert transforms have been adopted in combination with various classification techniques such as expert systems, Artificial Neural network, fuzzy logic and support vector machine [20-26] for the motor degradation. Most of the works done in this area are either based on modeling of induction motor or need an elaborate arrangement of costly and complex equipment for frequency domain analysis.

Eminent interest has been shown in [27-29] for artificial neural network in fault detection of induction motor. The necessary condition to contrivance a successful ANN classifier is the selection of appropriate inputs about each case of fault. In [27-28], stator inter turn fault location detection by ANN is described considering frequency domain parameters as selected input.

Time domain analysis avoids sophisticated techniques like FFT, DFT and usage of spectral analyzer. There is a demand to detect the hardness level of stator winding shorting as minor shorting in stator winding can repaired and reduce maintenance cost. Commercially available motor protection units like REM 610 (ABB) and Multilin 469 (GE) are enhanced with an optional add-on card with thermistors or RTD sensors that are used for temperature measurement of bearings and windings. Fault detection at earlier phase gives the viability of repairing the motor and a nip in the bud avoids electrical spark and explosion. Advancement in the stator winding fault detection area is required by introducing a classification technique like artificial neural network.

Most of the research works in induction motor stator winding fault detection are from the analysis of frequency domain. Author work in [29], ANN is applied for detecting severity of inter coil fault with selected parameter from time domain. The work in [30-32] focus on negative sequence current which is caused due to unbalanced windings.

In the research work [33] the authors have done the analysis of faulty three phase induction motor by investigating the analytical method of winding functions. This method neglects the influence of harmonics at the fault instant and neglects the non-linearity of the magnetic materials. Airgap flux density distribution and the harmonics of flux were examined in [34], in which they used ANSYS finite element software of high computational accuracy to extract the contents of harmonic amplitude and to perform asynchronous motor simulation. Time-domain Finite Element method is adopted in the research work[35] for the analysis of the eddy current of a rotating disc in a time-variant field, since there is no general analytical method for solving

Comparing the computational complexity of finite element analysis with that of Simulink modeling, simulink model can be easily constructed using mathematical model which describes a system.

Author in this work try to identify a fault indicating parameter from time domain to avoid signal processing techniques thereby simplify the existing fault detection method. Author attempts to find a detection technique for stator winding fault by using artificial neural network based on per unit value of sequence components of current. Here network has been trained with full range of input vector obtained from a Simulink model. Fault detection in the initial stage increases the viability of repairing the machine and a nip in the bud avoids electrical spark and explosion.

II. MATHEMATICAL MODELLING OF STATOR WINDING TURN FAULT

A three-phase induction motor with turn fault in one phase stator winding is considered, where β is the fraction of shorted turns. Winding in this phase has two parts -shorted turns and un-faulted turns. Machine equations in abc variables for a symmetrical motor with turn fault in one winding can be expressed as [36-38].

$$\mathbf{v}_s = \mathbf{R}_s \mathbf{i}_s + \frac{d\lambda_s}{dt} \quad (1)$$

$$0 = \mathbf{R}_r \mathbf{i}_r + \frac{d\lambda_r}{dt} \quad (2)$$

where

$$\mathbf{v}_s = [v_{as1} \ v_{as2} \ v_{bs} \ v_{cs}]^T \quad (3)$$

$$\mathbf{i}_s = [i_{as} \ (i_{as} - i_f) \ i_{bs} \ i_{cs}] \quad (4)$$

$$\mathbf{i}_r = [i_{ar} \ i_{br} \ i_{cr}]^T \quad (5)$$

$$\begin{aligned} \lambda_s &= [\lambda_{as1} \ \lambda_{as2} \ \lambda_{bs} \ \lambda_{cs}]^T \\ &= \mathbf{L}_{ss} \mathbf{i}_s + \mathbf{L}_{sr} \mathbf{i}_r \end{aligned} \quad (6)$$

$$\begin{aligned} \lambda_r &= [\lambda_{ar} \ \lambda_{br} \ \lambda_{cr}]^T \\ &= \mathbf{L}_{sr}^T \mathbf{i}_s + \mathbf{L}_{rr} \mathbf{i}_r \end{aligned} \quad (7)$$

The resistance matrices of equation (1) are given below

$$\mathbf{R}_s = R_s \text{diag}[1 - \beta \ \beta \ 0 \ 0] \quad (8)$$

$$\mathbf{R}_r = R_r \mathbf{I}_{3 \times 3}$$

Adding the first two rows of equation (1)

$$v'_s = R_s i_s + \frac{d\lambda'_s}{dt} + \beta \mathbf{A}_1 i_f \quad (9)$$

$$0 = R_\gamma i_\gamma + \frac{d\lambda_\gamma}{dt} \quad (10)$$

Where

$$\mathbf{v}'_s = [v_{as} \ v_{bs} \ v_{cs}]^T \quad (11)$$

$$\mathbf{i}'_s = [i_{as} \ i_{bs} \ i_{cs}]^T \quad (12)$$

$$\begin{aligned} \lambda'_s &= [(\lambda_{as1} + \lambda_{as2}) \ \lambda_{bs} \ \lambda_{cs}]^T \\ &= \mathbf{L}'_{ss} \mathbf{i}'_s + \mathbf{L}'_{sr} \mathbf{i}_r + \beta \mathbf{A}_2 \mathbf{i}_f \end{aligned} \quad (13)$$

$$\lambda_\gamma = \mathbf{L}'_{srT} \mathbf{i}'_s + \mathbf{L}_{\gamma\gamma} \mathbf{i}_\gamma + \beta \mathbf{A}_3 \mathbf{i}_f \quad (14)$$

$$\mathbf{A}_1 = -[R_s \ 0 \ 0]^T \quad (15)$$

$$\mathbf{A}_2 = [-(L_{ls} + L_{ms}) \ L_{ms}/2 \ L_{ms} / 2]^T \quad (16)$$

$$\mathbf{A}_3 = -L_{ms} [\cos \theta_\gamma \ \cos(\theta_r + 2\pi/3) \ \cos(\theta_\gamma - 2\pi/3)]^T \quad (17)$$

Inductance matrices are modified as

$$\mathbf{L}'_{ss} = \begin{bmatrix} L_{ls} + L_{ms} & -L_{ms}/2 & -L_{ms}/2 \\ -L_{ms}/2 & L_{ls} + L_{ms} & -L_{ms}/2 \\ -L_{ms}/2 & -L_{ms}/2 & L_{ls} + L_{ms} \end{bmatrix} \quad (18)$$

$$\mathbf{L}'_{sr} = L_{ms} \begin{bmatrix} \cos \theta_r & \cos(\theta_r + 2\pi/3) & \cos(\theta_r - 2\pi/3) \\ \cos(\theta_r - 2\pi/3) & \cos \theta_r & \cos(\theta_r + 2\pi/3) \\ \cos(\theta_r + 2\pi/3) & \cos(\theta_r - 2\pi/3) & \cos \theta_r \end{bmatrix} \quad (19)$$

The voltage and flux linkage equations for the shorted turns(βs_2) are

$$V_{as2} = \beta R_s (i_{as} - i_f) + \frac{d\lambda_{as2}}{dt} = R_f i_f \quad (20)$$

$$\lambda_{as2} = -\beta \mathbf{A}_2^T \mathbf{i}'_s - \beta \mathbf{A}_3^T \mathbf{i}_\gamma - \beta (L_{ls} + \beta L_{ms}) i_f \quad (21)$$

The expression of electromagnetic torque can be in machine abc variables is

$$T = \frac{P}{2} \mathbf{i}_s^T \frac{\partial \mathbf{L}_{sr}}{\partial \theta_\gamma} \mathbf{i}_\gamma \quad (22)$$

The inductance matrices are given by (23)-(25)

$$\begin{aligned} \mathbf{L}_{ss} &= L_{ls} \text{diag}[1 - \beta \ \beta \ 0 \ 0] + \\ &\begin{bmatrix} (1-\beta)^2 & \beta(1-\beta) & -(1-\beta)/2 & -(1-\beta)/2 \\ \beta(1-\beta) & \beta^2 & -\beta/2 & -\beta/2 \\ -(1-\beta)/2 & -\beta/2 & 1 & -1/2 \\ -(1-\beta)/2 & -\beta/2 & -1/2 & 1 \end{bmatrix} \end{aligned} \quad (23)$$

$$\mathbf{L}_{sr} = L_{ms} \begin{bmatrix} (1-\beta) \cos \theta_\gamma & (1-\beta) \cos(\theta_\gamma + 2\pi/3) & (1-\beta) \cos(\theta_\gamma - 2\pi/3) \\ \beta \cos \theta_\gamma & \beta \cos(\theta_r + 2\pi/3) & \beta \cos(\theta_r - 2\pi/3) \\ \cos(\theta_r - 2\pi/3) & \cos(\theta_r) & \cos(\theta_r + 2\pi/3) \\ \cos(\theta_r + 2\pi/3) & \cos(\theta_r - 2\pi/3) & \cos(\theta_r) \end{bmatrix} \quad (24)$$

$$\mathbf{L}_{rr} = \begin{bmatrix} L_{lr} + L_{ms} & \frac{-L_{ms}}{2} & \frac{-L_{ms}}{2} \\ \frac{-L_{ms}}{2} & L_{lr} + L_{ms} & \frac{-L_{ms}}{2} \\ \frac{-L_{ms}}{2} & \frac{-L_{ms}}{2} & L_{lr} + L_{ms} \end{bmatrix} \quad (25)$$

III. SEQUENCE COMPONENT ANALYSIS AND PARAMETER EXTRACTION

The symmetrical components are solid tool for analyzing and solving the problems of any unbalanced system. The symmetrical components are found reliable indicators of stator turn faults. By principle symmetrical (without fault) motors supplied with symmetrical three phase voltage sources will not produce negative sequence currents. When a turn fault occurs, symmetry will disturb and generate negative and zero sequence currents. In reference to the symmetrical components practice three sets of symmetrical balanced phases are derived from any set of unbalanced parameters. They are recognized as positive, negative and zero sequence components. Using Fortescue's transformation given by equation (26), symmetrical components (I_1, I_2, I_0) are calculated from unbalanced phase currents (I_a, I_b, I_c).

$$\begin{bmatrix} I_1 \\ I_2 \\ I_0 \end{bmatrix} = 1/3 \begin{bmatrix} 1 & a & a^2 \\ 1 & a^2 & a \\ 1 & 1 & 1 \end{bmatrix} \begin{bmatrix} I_a \\ I_b \\ I_c \end{bmatrix} \quad (26)$$

$$\text{Where } a = e^{j\frac{2\pi}{3}} \quad (27)$$

Fundamentally, the three-phase induction motor is a symmetrical system in healthy conditions and produces only positive sequence currents. It generates positive, negative and zero sequence when symmetry disturbs during a fault situation.

MATLAB software is used for creating simulation model of three phase motor with turn fault in one of the phase winding. Due to the difficulty in creating the fault and measuring the phase currents experimentally for high value of percentage shorting we are forced to create the Simulink model. Simulink of induction motor with stator winding shorting is constructed based on the fundamental equations mentioned in section II. Simulink model of motor with interturn short is shown in Figure.1.

During the simulation phase current values are get stored in the workspace of MATLAB. From these values, negative sequence current, positive sequence current and zero sequence currents are calculated. Phase currents and sequence currents for different shorting levels are tabulated in Table.I. Here simulation is carried out by introducing short circuiting in one phase at a time. Short circuiting level has been increased from zero percentage to 20 percentage gradually. Negative sequence component of current is found to be increasing gradually with increase in short circuit level.

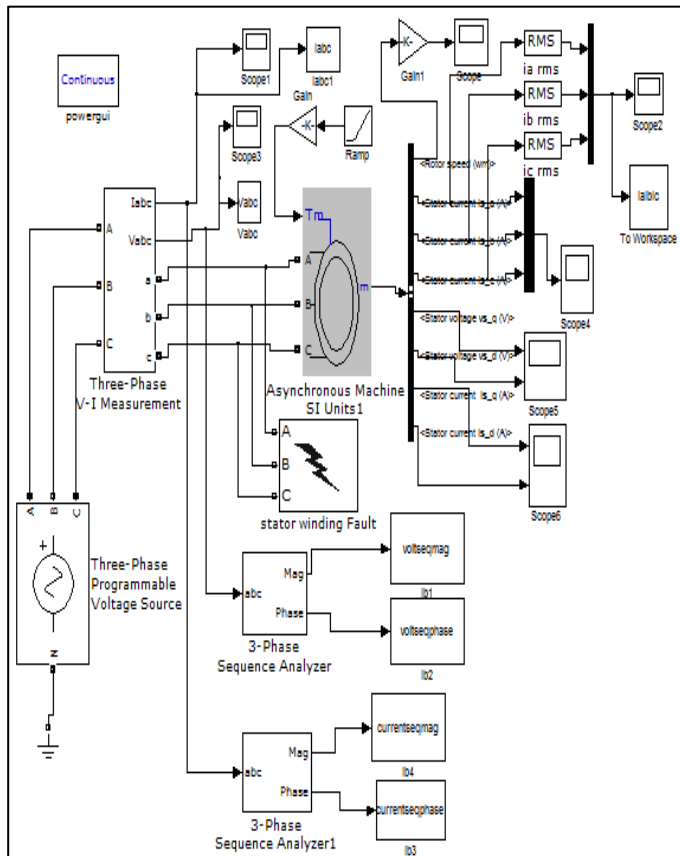

Figure.1 Simulink model for extraction of sequence components of current and voltage.

TABLE.I
MAGNITUDE OF PHASE CURRENTS AND SEQUENCE COMPONENTS OF PHASE CURRENTS

% shorting in phase-A winding	Phase current values			Sequence component of current values		
	Ia	Ib	Ic	I positive	I negative	I zero
0	10.1651	10.162	10.165	10.0248	0	0
0.233	10.252	10.17	10.1705	10.0289	0.0042	0.0043
0.467	10.339	10.17	10.1705	10.0329	0.0085	0.0085
0.7	10.4259	10.17	10.1705	10.037	0.0127	0.0127
0.933	10.5129	10.17	10.1705	10.0411	0.0169	0.0169
1.167	10.5998	10.17	10.1705	10.0452	0.0212	0.0212
1.4	10.6867	10.17	10.1705	10.0493	0.0254	0.0254
1.633	10.7737	10.17	10.1703	10.0534	0.0296	0.0296
1.867	10.8606	10.17	10.1703	10.0574	0.0338	0.0339
2.1	10.9476	10.17	10.1703	10.0615	0.0381	0.0381

2.333	11.0345	10.17	10.1705	10.0656	0.0423	0.0423
3.5	11.1932	10.17	10.1704	10.1074	0.0862	0.0862
4.667	11.3508	10.17	10.1704	10.1498	0.1309	0.1309
5.833	11.5174	10.17	10.1704	10.1951	0.1784	0.1784
7	11.6899	10.17	10.1704	10.2406	0.2255	0.2255
8.167	11.8631	10.17	10.1704	10.2859	0.2737	0.2737
9.333	12.0455	10.17	10.1702	10.3337	0.3238	0.3238
10.5	12.2366	10.17	10.1702	10.3825	0.3755	0.3755
11.667	12.4291	10.17	10.1702	10.4301	0.4274	0.4274
13.333	12.6072	10.17	10.1702	10.4777	0.4768	0.4768
15	12.6254	10.17	10.1697	10.4803	0.4809	0.4809

This data is verified by conducting experiments on two motors rated 5HP and 1HP three phase induction motor. Three phase induction motor of Kirloskar electric company having specification 3.728kW, 1430rpm, 415V, 10A and a digital oscilloscope-DS 1150 are used for experiment.



Figure.2 Experimental setup of three phase IM with shorting in one phase

TABLE.II
COMPARISON OF PHASE CURRENT VALUES OBTAINED FROM SIMULATION AND EXPERIMENT

Sl. No	Shorting percentage in phase-A winding	Phase current values obtained from		Error percentage
		Experiment	Simulation	
1	0	10.2	10.1651	0.0034216
2	0.7	10.4	10.4259	-0.0024904
3	1.4	10.7	10.6867	0.00124299
4	2.1	10.9	10.9476	-0.00436697
5	3.5	11.2	11.1932	0.000607142
6	7	11.7	11.6899	0.000901785
7	10.5	12.2	12.2366	-0.00300

8	15	12.6	12.6254	-0.00201587
---	----	------	---------	-------------

The experimental setup of stator inter-turn fault is shown in Figure.2. Inter turn short circuit is created by taking out tapings from one of the phase winding. Table. II gives the comparison of phase current values of winding with shorted turns from experiment setup and that from Simulink model. Experimental values and simulated values are comparable since error percentage of both values is very low, thus proves the authenticity of the Simulink model.

For 5HP motor, current values obtained practically is compared with those obtained from Mathematical model, described under section II. The details of winding parameters used for calculation are

Stator resistance, $R_s=0.2777\Omega$
Rotor resistance, $R_r=0.183\Omega$
Stator inductance, $L_s=0.0553H$
Rotor inductance, $L_r=0.056H$
Mutual inductance, $L_m=0.0538H$

TABLE.III
COMPARISON OF PHASE CURRENT VALUES OBTAINED FROM EXPERIMENT AND MATHEMATICAL MODEL

Sl.No	β (fraction of shorted turns)	Phase current values obtained from		Error percentage
		Mathematical model	Simulation	
1	0.007	10.386	10.4259	-0.00384171
2	0.014	10.695	10.6867	0.007760636
3	0.021	10.921	10.9476	-0.002435674
4	0.035	11.193	11.1932	-0.001786831
5	0.07	11.684	11.6899	-0.00504964
6	0.105	12.243	12.2366	0.0005227477
7	0.15	12.630	12.6254	0.0036421219
8	0.18	12.828	12.832	-0.00311817

Percentage error between simulation values and mathematical model values listed in Table III are very low. Comparison output shows compliance or proves the validity of Simulink model.

The per unit change in negative sequence current with positive sequence current is considered as the main input parameter for classification of shorting level in phase windings.

$$X = \frac{[Positive\ sequence\ current - Negative\ sequence\ current]}{Positive\ sequence\ current}$$

$$X = (I_p - I_N) / I_p$$

Case1: with zero percentage shorting (healthy)

$$I(\text{negative}) = 0$$

$$I(\text{positive}) = 10.0248$$

so $X=1$

Case.2: Turn fault of 1.4 percentage

$$I(\text{negative}) = 0.0254$$

$$I(\text{positive}) = 10.0493$$

$$X = (10.0493 - 0.0254) / 10.0493 = 0.997472461$$

The value of X for various levels of short circuiting is tabulated in Table. IV. Selection of effective parameter is very important in fault detection along with the selection of classifier.

TABLE.IV
CALCULATED PARAMETER VALUES

Sl.no	Percentage shorting in phase-winding	$X = [I(\text{positive}) - I(\text{negative})] / I(\text{positive})$
1	0	1
2	0.233	0.99958121
3	0.467	0.999152787
4	0.7	0.998734682
5	0.933	0.998316917
6	1.167	0.997889539
7	1.4	0.997472461
8	1.633	0.997055722
9	1.867	0.99663929
10	2.1	0.996213288
11	2.333	0.995797568
12	3.5	0.991471595
13	4.667	0.987103194
14	5.833	0.982501398
15	7	0.977979806
16	8.167	0.973390758
17	9.333	0.968665628
18	10.5	0.963833373
19	11.667	0.959022445
20	13.333	0.95449383

Generalization capacity of fault Indicator parameter (X) has been checked for five motors. The specifications of motors (I to V) considered for analysis are

- M I- 1.1KW, 400V, 50Hz, 1447rpm, 2.7A
- M II- 5.5KW, 400V, 50Hz, 1457rpm, 11.6A
- M III- 55KW, 400V, 50Hz, 1480rpm, 102A
- M IV- 110KW, 400V, 50Hz, 1487rpm, 194A
- M V- 250KW, 400V, 50Hz, 1488rpm, 445A

The value of X varies from 1 to 0.954 for short circuit levels 0% to 15%. In this case the input vector to NN or fault indicator

values (X) are identical for all motors for a specific fault level. Figure.3 shows the variation of X values at different inter -turn fault levels for motors under analysis.

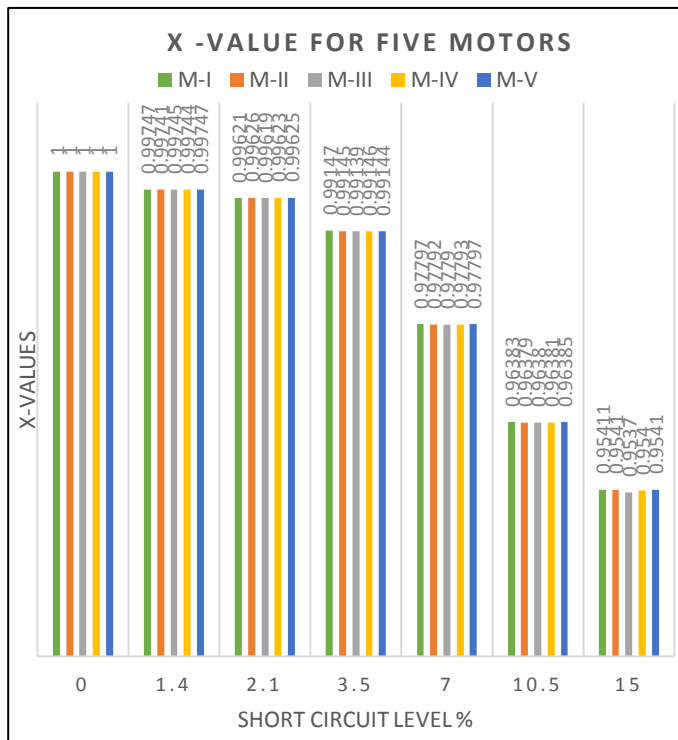

Figure.3 Variation of X values for motors (M-I to M-V) at different inter -turn fault levels

IV. NEURAL NETWORK FOR CLASSIFICATION

The Artificial neural network consists of several interconnected neurons. Since ANNs are indulgent to noise and responds quickly, it can be employed in real time fault detection [27-29]. Since it is not possible to create a look -up table storing data for all conditions, a feed forward neural network is used for classifying the fault. Anticipating maximum accuracy from the trained neural network, input vector is created using possible experimental values and Simulink values for high percentage shorting. The various processes involved in the work of detection of severity level of shorting in stator winding is described in the block diagram, Figure.4.

The design and development of neural networks comprises of preparation of input data set for the neural network, selection of a network structure, training of the network, testing and evaluation of the classifier.

Backpropagation (BP), which is the most popular supervised learning method is adopted for this process. This learning algorithm increases the efficiency of the network by minimizing the error and so the gradient of the error curve slopes down. The input data to NN are array of value of X. Target value is fixed for each value of input, X. Both input data and target values are displayed in Table.V.

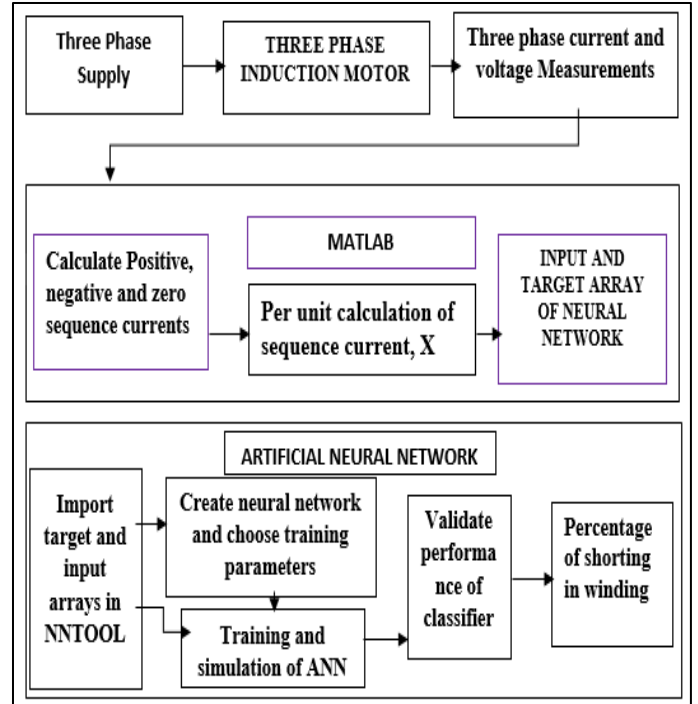

Figure.4 Block diagram of processes

TABLE V
INPUT AND TARGET VALUES OF ANN

$X = [I(\text{positive}) - I(\text{negative})] / I(\text{positive})$	ANN classifier Target value	% shorting/ severity level
1	10000	0
0.99958121	10023	0.233
0.999152787	10046	0.467
0.998734682	10070	0.7
0.998316917	10093	0.933
0.997889539	10116	1.167
0.997472461	10140	1.4
0.997055722	10163	1.633
0.99663929	10186	1.867
0.996213288	10210	2.1
0.995797568	10233	2.333
0.991471595	10350	3.5
0.987103194	10466	4.667
0.982501398	10583	5.833
0.977979806	10700	7
0.973390758	10816	8.167
0.968665628	10933	9.333
0.963833373	11050	10.5
0.959022445	11166	11.667
0.954493883	11333	13.333
0.954113909	11500	15
0.954000839	11667	16.667
0.948959154	11800	18
0.943823196	11916	19.167
0.938604651	12033	20.334

Target value [10000] represents healthy condition of winding. Target [10023] for 0.233% of shorting, [10233] for 2.333% of shorting, [11500] for 15% of shorting, there by clearly classifies the severity level of fault.

The performance of the algorithm is sensitive to the setting of the learning rate. A very small learning rate will lead to longer converging time and a very high learning rate can lead to oscillating and unstable algorithm. Backpropagation training with an adaptive learning rate is implemented with Gradient Descent function

Hyperbolic tangent sigmoid transfer function is used, which calculates a layer's output from its net input. Mean squared normalized error performance function measures the network performance according to the mean of squared errors, when incorporated into the training process enhances the efficiency of the synaptic weight adjustment. A very low MSE reflects that the desired output and the ANNs outputs are close to each other, and thereby the network is well trained.

V. RESULT AND PERFORMANCE VALIDATION

The Proposed networks were subjected to training with input signals as described in neural network development section. While analysing the performance and regression plot of networks it has been found that neural network reacted well with training and validation samples. Validation performance of network gave 100% accuracy (with 50 samples). So, accuracy percentage is calculated with error between target value and actual output vector. The level of accuracy obtained is 99.05%. The performance plot of neural network is given in Figure.5. Stopping criterion is established with means squared error of $1.02e-005$.

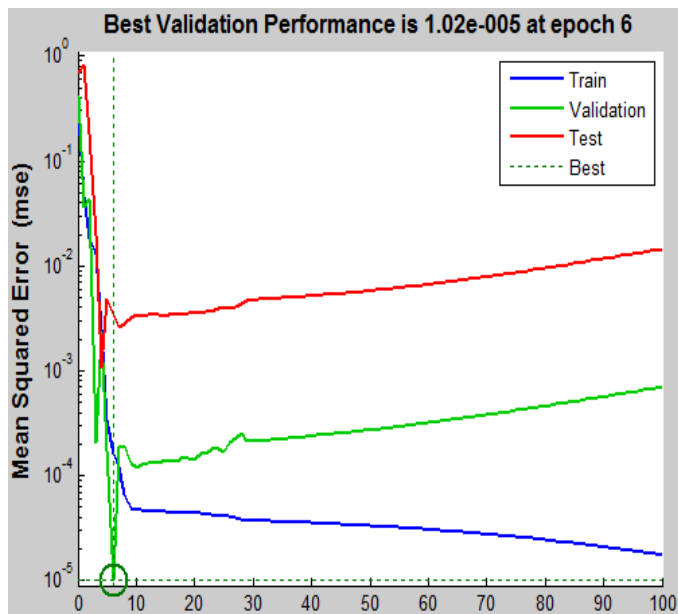

Figure.5 Performance plot of trained network

VI. CONCLUSION

This research focus is to make progress as well as simplify the field of condition monitoring and fault detection in induction motor. Negative sequence current monitoring is one of simplest but solid and substantial technique for stator short circuit detection. In this work per unit change in negative sequence current with positive sequence current is considered as the fault indicator and so found to be more generalized technique for inter turn stator winding fault detection. It is relevant to specify that selection of fault indicating parameter is as critical as selection of classification method. The work presents application of neural network to classify the stator inter turn fault. The network is trained with full range of input vector using experimental values (for small level of shorting) as well as Simulink values (for high level of shorting). The performance of the NN is found to be accurate and fast. Since there is no hard and fast rule in deciding the structure of neural network, extensive experiments were conducted to determine the optimized structure. Fault detection in the beginning stage increases the feasibility of repairing the machine and avoids the risk of fire and explosion. Future extension of NN is possible to account detection of other electrical and mechanical faults possible with induction motor.

VII. ACKNOWLEDGEMENT

This work is carried out at state-of-the-art Power System Protection Lab, Department of Electrical and Electronics Department, KCG College of Technology, Chennai, India, under the Scheme "Fund for Improvement of S&T Infrastructure (FIST)" supported by Department of Science and Technology (DST), Government of India.

VIII. REFERENCES

- [1] M.-Y.Chow, "Guest editorial special section on motor fault detection and diagnosis", IEEE Transactions on Industrial Electronics, vol.47, no.5, pp.982-983, October 2000.
- [2] William T. Thomson and Ronald J.Gilmore, "Motor current signature analysis to detect faults in induction motor drives", Proc. Thirty second turbo machinery symposium, Texas, pp 145-156, 2003.
- [3] P.J.Travner, "Review of condition monitoring of rotating electrical machines, IET Electrical Power Application", Vol.2, No.4, pp.215-247, 2008.
- [4] T.W.Chua, W.W.Tan,Z-X.Wang and C.S.Chang, "Hybrid time frequency domain for inverter fed induction motor fault detection", IEEE International Symposium on Industrial Electronic(ISIE), pp.1633-1638,4-7 July 2010.
- [5] A. Widodo, Bo-suk Yang, Dong-Sik Gu and Byeong-Keun Choi, "Intelligent fault diagnosis system of induction motor based on transient current signal", Mechatronics, Vol.19, Issue.5, pp.680-689, Aug. 2009.
- [6] F. Karami, J.Poshtan and M.Poshtan, "Detection of broken rotor bars in induction motor faults in inverter drives using inverter input current analysis", IEEE Transactions on Industrial Electronics, Vol.55, No.9, pp.4365-4373, September 2011.
- [7] D.Matic, F.Kulic, I.Kamenko, V.Bugariski and P. Nikolic, "Design of Support Vector Machine Classifier for Broken bar detection", IEEE International Conference on Control Applications, Croatia, pp-1670-1673, 3-5 October 2012.

- [8] Mahdi Gordi Armaki and Reza Roshanfekar, "A new approach for fault detection of Broken rotor bars in induction motor based on support vector machine", Proc. of 18th Iranian conference on Electrical Engg(ICEE), July 2010.
- [9] A.M. Trzynadlowski, R.Ritchie, "Comparative investigation of diagnostic media for induction motors: a case of rotor cage faults", IEEE Transactions on Industrial Electronics, Vol.47, No.5, pp 1092-1099, 2000.
- [10] Jafar Zarei, Mohammad Mehdi Arefi and Hossein Hassani, "Bearing fault detection based on interval type-2 fuzzy logic systems for support vector machines", 6th international conference on modelling, simulation and applied optimization(ICMSAO), Turkey, May 2015.
- [11] V.N. Ghate and S.V. Dudul, "Optimal MLP neural network classifier for fault detection of three phase induction motor", Expert System with Applications, 37, pp.3468-3481, 2010.
- [12] R. Sharif and M. Ebrahimi, "Detection of stator winding faults in induction motors using three phase current monitoring", ISA Transactions, 50, pp. 14-20, 2011.
- [13] A. Cakir, H.Calis, E.U.Kucuksille, "Data mining approach for supply unbalance detection in induction motor", Expert System with Applications, 36, pp. 11808-11813, 2009.
- [14] Elmore, W. A. "Protective Relaying theory and applications". New York, NY: Marcel Dekker, Inc. 2004
- [15] J.Penman, H.G.Sedding, B.A.Lloyd and W.T.Fink, "Detection and location of inter turn short circuits in the stator windings of operating motors", IEEE Trans. Energy Conversion, vol.9, no.4, pp 652-658, 1994.
- [16] G.C.Stone and H.G. Shedding, "In-Service evaluation of motor and generator stator windings under partial discharge tests", IEEE Trans.Ind. Appli. vol31, no.2, pp229-303,1995.
- [17] R.Natarajan, "Failure identification of induction motors by sensing unbalanced stator currents", IEEE Trans.Energy conversion, vol.4, no.4, pp.585-590, 1989.
- [18] A.H. Bonnett and G.C.Soukup, "Cause and analysis of stator and rotor failures in three phase squirrel cage induction motors", IEEE Trans. Industry Applications, Vol.28, no.4, pp.921-937, 1992.
- [19] G.B.Kliman, W.J.Premelani and R.A.Koeg, "A new approach to online turn fault detection in AC motors", in Proc. IEEE-IAS annual meeting, New York, vol.1,pp.687-693, 1996.
- [20] J.Burriel-Valencia, M.Pineda-Sanchez, J.Martinez-Roman, R.Puche-Panadero, A.Sapena-Bano, "Study of performance of several techniques of fault diagnosis for induction motors in steady-state with SVM learning algorithms", second International Conference on Artificial Intelligence, modeling and simulation, Spain, Nov 2014.
- [21] A.P. Mittal, Hasmat Malik, Saarang Rastogi, Vihan Talur, "External fault identification by 3-phase induction motor using PSVM", Power India international Conference (PIICON), Delhi, India June 2015.
- [22] Zhengkai Zhang, Lichen Gu, Yongsheng Zhu, "Intelligent fault diagnosis of rotating machine based on SVMs and EMD method", The open automation and control systems journal, 7(1), 219-230, June 2015.
- [23] Yamuna K.Moorthy, Pournami S.Chandran and Rishidas S, "Motor current signature analysis by multi resolution methods using support vector machine", Recent Advances in intelligent computational systems(RAICS), IEEE, November 2011.
- [24] Claude DELPHA, Hao CHEN and Demba DIALLO, "SVM based diagnosis of inverter fed induction machine drive: a new challenge", 38th Annual conference on IEEE Industrial Electronics Society [IECON], Montreal, QC, Canada, October 2012.
- [25] D.R.Sawitri, D.A.Asfani, M.H.purnomo, I.K.E.Purnama, M.Ashari, "Early detection of unbalance voltage in three phase induction motor based on SVM", 9th IEEE international Symposium on diagnostics for Electric machines, power electronics and drives(SDEMPED), Valencia, Spain October 2013.
- [26] Jose D. Martinez-Morales, E.palacios, D.U.Campos-Delgado, "Data fusion for multiple mechanical fault diagnosis in induction motors at variable operating conditions", 7th international conference on electrical engineering, computing science and automatic control(CCE 2010) Chiapas, Mexico, September 8-10, 2010.
- [27] M. Bouzid, G. Champenois, N.Bellaj, L.Signac, K.Jelassi, "An effective neural approach for the automatic location of stator inter turn faults in induction motor", IEEE Trans. Industr.Electron., vol.55, no.12, pp.4277-4289, December 2008.
- [28] M. Bouzid, N. Bellaj, K.Jelassi, G. Champenois, I. Signac, "Location of an inter turn short circuit fault in the stator windings of induction motor by neural network", IEE, IET, The institute of engineering and technology, Colloquium on reliability in electromagnetis systems, Paris, France 24-25 May 2007.
- [29] Gayatri Devi Rajamany, Sekar Srinivasan, "An artificial neural networks application for the automatic detection of severity of stator inter coil fault in three phase induction motor", Journal of electrical engineering and technology, vol.12, no.6, pp 2219-2226, November 2017.
- [30] Rangarajan M. Tallam, Gerald B.Kliman and Ronald G.Harley, "A survey of methods for detection of stator-related faults in induction machines", IEEE Transactions on Industry Applications, vol.43, No.4, PP 920-928, August 2007.
- [31] Pero Ostojic, Arjit Banerjee and Dhaval Patel, "Advanced motor monitoring and diagnostics", IEEE Transactions on Industry Applications, vol.50, Issue.5, pp 3120-3127, October 2014.
- [32] S.Samanta, J.N.Bera and G.Sarkar, "Inter turn fault diagnosis of three phase induction motor using SST and KNN", Michael Faraday IET International Summit, MFIS-Kolkata, India September 2015
- [33] Elhajja-Abu, W. S., Jawad Fiaz & Bashir Mahdi Ebrahimi "Analytical Prediction of Instantaneous torque and speed for induction motors with Mixed-Eccentricity fault using magnetic-Field equations" Electromagnetics., 25(6):525-540, 2010.
- [34] Yu Mingxing, Jiazheng Zhu, and Xing Wang, "Numerical analysis of Finite element combined simulation model for Three phase squirrel-cage Induction motor" DOI: 10.23919/ChiCC. 2017.8028983. 2017
- [35] M.Talaat and N. H. Mostafa, "Use of Finite element method for the Numerical Analysis of eddy current brake". IEEE 15th International Workshop on Research and Education in Mechatronics, (REM 2014), pp. 1-7, 2014.
- [36] AVJS Praneeth, K.S.Sindhu and Nagendra Bhaskar, "Abberant analysis of three phase induction machine with stator inter turn faults on windings", Biennial International Conference on Power and energy systems: Towards Sustainable Energy(PESTSE), Bangalore, India, January 2016
- [37] Maciej Wieczorek and Eugeniusz Rosolowski, "Modelling of induction motor for simulation of internal fault", Proceedings of the International Symposium on Modern electric power systems(MEPS), Wroclaw, Poland, September 2010.
- [38] D.A.Asfani, Pressa Pradana Surya Saputra and I.M.Yulistya Negara, "Simulation analysis on high impedance temporary short circuit in Induction motor winding", International conference on quality in research, Yogyakarta, Indonesia, June 2013.