

A NOVEL CONTROL STRATEGY FOR DAMPING FURNACE PRESSURE OSCILLATIONS OF A THERMAL POWER PLANT IN VIETNAM

Dr. Ngockhoat NGUYEN

Faculty of Automation Technology, Electric Power University
235 Hoang Quoc Viet Str, Hanoi, Vietnam, Email: khoatnn@epu.edu.vn

Abstract:

It is the fact that oscillation phenomenon of furnace pressure of a unit in a thermal power plant can negatively affect the normal operation of the power station. If this phenomenon is not damped fast enough, it may cause the furnace shutdown. This paper presents a newly practical control strategy regarding the design and improvement of the control part of an oil burner system for a thermal power plant in Vietnam. The control scheme aims to avoid the shutdown of the furnace flame when the furnace pressure oscillates. The control solution proposed in this paper includes two parts: a decrease of the duration of oil burner start sequence and an automatic start-up of the oil burner when the furnace pressure oscillates. The solution has been successfully and efficiently applied for a 330MW unit of the thermal power station in Vietnam. Applying the proposed control strategy, the stability, reliability and high efficiency of the unit of the thermal power station can be guaranteed. Practical results during the operation of the unit present superior achievements of the proposed control solution over those of an operating unit with gas and air control system in manual control mode.

Key words: furnace pressure, oscillation, furnace flame, oil burner system, automatic start-up, oil valve logic improvement.

1. Introduction.

The Uong Bi Thermal Power Plant Project involves the construction of a 330 MW generating unit located in Uong Bi City, Quang Ninh province, Vietnam. This project actually included the design, fabrication, supply, construction, installation, commissioning and testing for operation and maintenance of the 330 MW power station. The project started in May, 2008 and finished in March, 2013; thereafter it is transferred to and executed in the Uong Bi thermal power plant.

During the trial run of the equipment and test run of the unit's operating modes, main equipment experienced a long over-repair period which slowed down the unit's progress. Then the unit was always operated in instability and unreliability states, regularly occurring faults of equipment and systems. Therefore, the unit might be turned off. Some faults such as the hydraulic coupling fail of the induced draft fan (IDF), sticky slags on the furnace wall and in the bottom ash handling system, and especially the oscillation of furnace pressure causing the shutdown of the furnace flame need to be fixed as soon as possible [1-5].

Figure 1 is an interface part of a supervisory control

and data acquisition (SCADA) system embedded in the power station, showing the effect of the furnace pressure fluctuation. The SCADA is one of the most important parts of the control system for the plant [6-10]. As shown in Fig. 1, when the furnace pressure signals (lines 2 and 3) fluctuate, the furnace pressure control system in manual mode does not take part in the regulation process. Therefore, two hydraulic coupling position signals of the IDF A and B do not make any change, increasing an ability to turn off the furnace flame and shutdown the boiler. In Fig. 1, at an instant when the pressures oscillate strongly enough, both of the furnace flame sensor signal and the MW power signal are immediately dropped to zeros (see lines 1 and 6 in Fig. 1). This is a bad problem which needs to be solved fast enough in order to ensure the stability of the thermal power plant [11, 12].

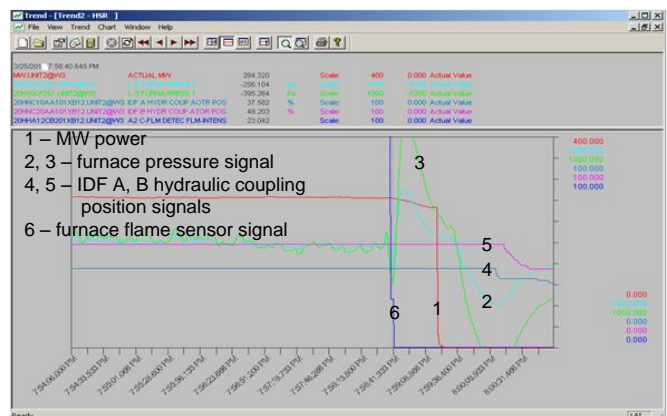

Fig. 1. Effects of the furnace pressure oscillation

There are a number of solutions in dealing with the above problem as follows:

- 1) The solution of changing fuel gas and air system control mode to auto mode. It is the fact that in this control solution, logic design for furnace pressure control loop and combustion air flow control loop is incomplete, commissioning process for fuel gas and air control system in auto mode is not performed and the induced draft fans respond slowly in control process.
- 2) The solution of unit combustion adjustment. Actually, the fuel gas and air control systems cannot operate in auto mode, hence these devices were not

calibrated to ensure a necessary accuracy and many actuators respond slowly.

- 3) The solution of improving the oil burner system which should be in automatic start mode, namely an automatic oil burner start-up, when the furnace pressure oscillates. It means that when the furnace pressure oscillates, the oil burner starts automatically to stabilize the furnace pressure, then forcing the oil burner to stop.

Among the above solutions, the automatic oil burner start-up is the best choice since it is the most effective and easiest solution to execute. Normally, the oil burner operates in manual control mode and oil burner start-up sequence takes a long time. Therefore, it is needed to improve the oil burner start process for reducing the duration of the oil gun start sequence and automatic start-up when the furnace pressure oscillates, thereby the stability of the system can be assured.

2. Analysis of the oil burner.

The components of oil burner consist of an oil gun, an igniter, an oil angle valve, an atomizing valve and a purge valve (see Fig. 2).

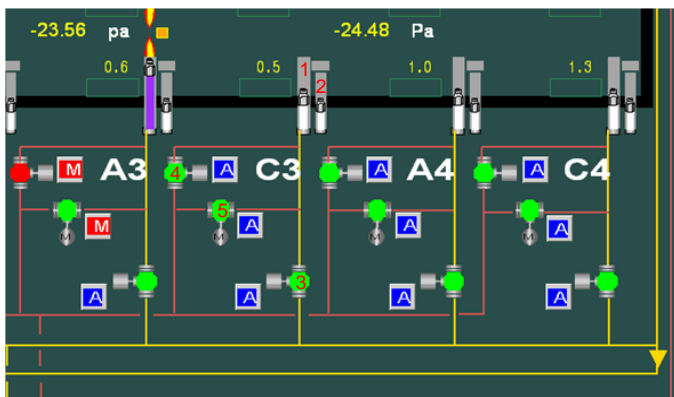

Fig. 2: The oil burner start sequence

As shown in Fig. 2, the oil burner start-up sequence is started with a step to push the oil gun in. After the oil gun has been taken in a right position, an igniter is pushed in. Thereafter, the atomizing valve must be opened properly. Then, the igniter begins sparking in a three-second delay, opening a corresponding oil angle valve. After the oil angle valve opened, if there is a 12-second detection of flame, an ignition is successful so that the oil burner start sequence was completed.

During the operation process of the plant, there are many times for a turning-off furnace flame due to the

oscillation of furnace pressure, and thus the boiler seems to be ceased. Several reasons causing the oscillation of the furnace pressure are as follows:

- a) The furnace combustion mode is unstable and has many slag deposits on the boiler wall.
- b) Fuel gas and air control system cannot be operated in the automatic mode, instead it must operate in manual mode so the fuel/air ratio requirements will not be satisfied.
- c) Pulverised coal feeder system for burners is unstable and the quality of coal seems to be not good enough.

The above reasons make the oscillations of the furnace pressure, requiring an optimal start-up of the oil burner system for stabilizing the furnace pressure. Therefore, it is necessary to improve the oil burner system in order to start the oil burner faster, thereby it might early stabilize the furnace pressure.

3. Proposed control solution and practical results.

The oil burner system start-up sequence takes a long time so it slowly responds when occurring the oscillation of furnace pressure. Therefore it should be needed to improve the system to reduce the duration of the oil burner start-up sequence and automatically start the oil burner when the furnace pressure oscillates. A procedure to deal with this problem is proposed as presented below:

Step 1: Change the oil burner control mode from automatic mode to manual mode after pushing the oil gun in and opening the atomizing valve for testing the oil burner start. Because the current temperature in the furnace is very high so it might be necessary to only open a corresponding oil angle valve, then oil shall be burnt. Therefore, when appearing the oscillation of furnace pressure, the technical solution is to only open the oil angle valve by manual, oil shall burn and the oil burner start process is not slow by the oil burner start-up sequence (see Fig. 3 in the next page).

As shown, Fig. 3 displays that oil guns are taken in right positions and the atomizing valves are in open position of oil burners: A2, A3, B3 and D2. The system should wait for an instant of the oscillation of furnace pressure, then immediately perform a task to open the oil angle valve by manual method and inspect the result.

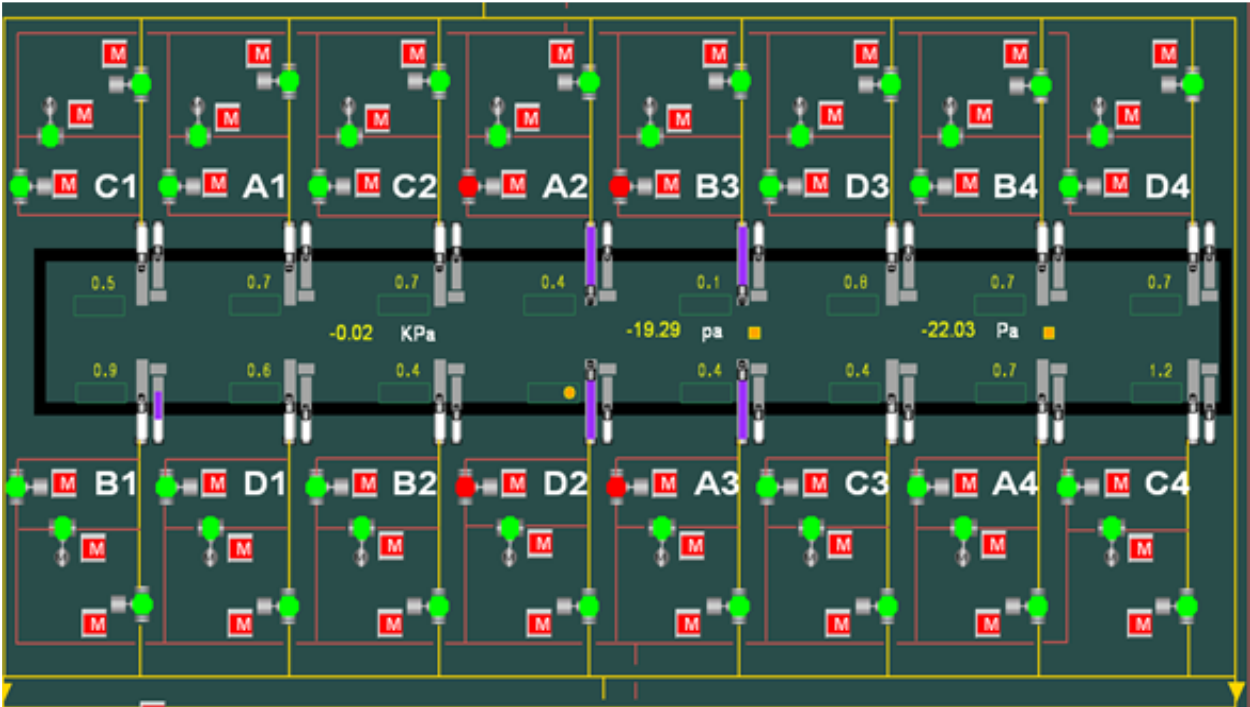

Fig. 3. Test of the oil burner start sequence by manual mode

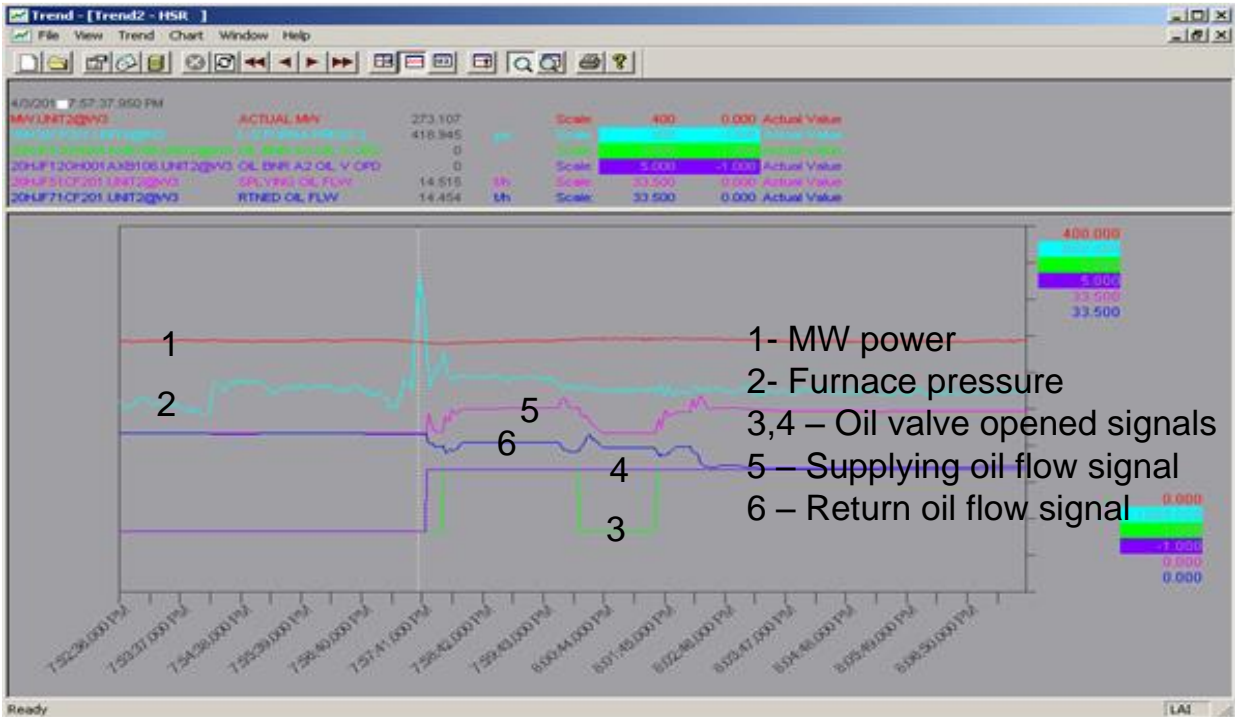

Fig. 4. Results for opening of the oil angle valve by manual mode

In Fig. 4, when the furnace pressure (line 2) oscillates, the operator should open the A2 and A3 oil valves by manual method, after the furnace pressure is stable (line 2). The results reveal that the duration of the oil burner start sequence is reduced and the furnace pressure is stable.

Step 2: Improve logic for the oil valves in order to make sure that the oscillations of furnace pressure appears, the oil valve automatically opens. To give a

high limit and a low limit of the furnace pressure for the oil valve to automatically open based on the times of the oscillations of furnace pressure to shutdown the boiler. Using trend history for the times of the oscillations of furnace pressure to shutdown the boiler, let us propose two high limit of +336pa and +308pa, and a low limit of -319pa. Therefore, it is reasonable to set a high limit and a low limit of the oil valve to automatically open the oil valve. These values must be

less than the above limits. In this practical control method, we set a high limit of the oil valve is +250pa and a low limit of the oil valve is -250pa.

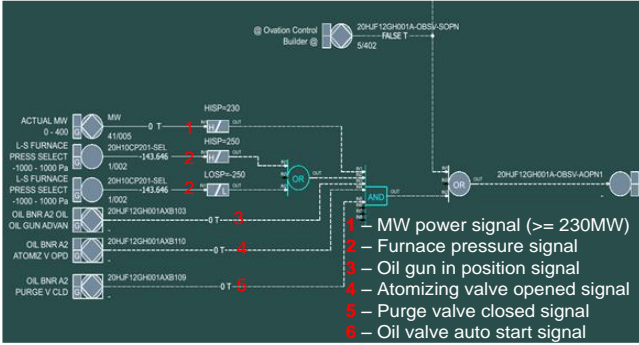

Fig. 5. Improvement of the oil valve logic for the oil valve in automatic opening

In Fig. 5, the oil valve logic is improved. It is automatically opened when all signals are satisfied through out a control signal (see line 6 in Fig. 5). Next, the oil valves A2, A3, B3 and D2 are changed into automatical mode, then the working results should be tested later.

Figure 6 shows that the oil guns are taken in correct positions, the atomizing valves are in open positions. Meanwhile, the oil valves in AUTO mode are A2, A3, B3 and D2, waiting for the oscillations of furnace pressure and inspection of results to automatically open the oil valves.

Figure 7 depicts the response of the plant which is working with a 289 MW load and the oscillation of the furnace pressure is -372pa, satisfying the required conditions to automatically open A2 and A3 oil valves. After A2 and A3 oil valves have been opened, the A2 and A3 oil burners are burned to make the furnace pressure stable (see line 2).

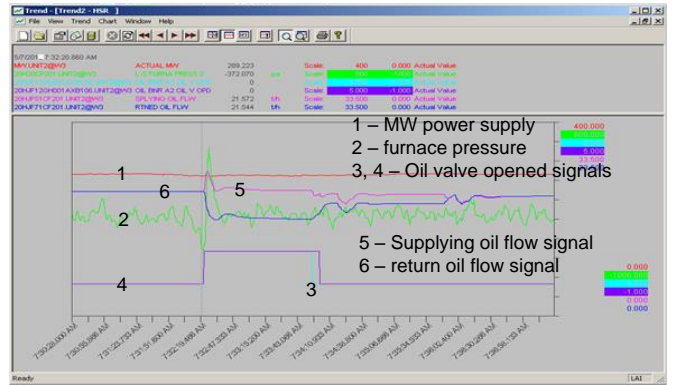

Fig. 7. Automatical opening of the oil valves when the furnace pressure is less than -250pa

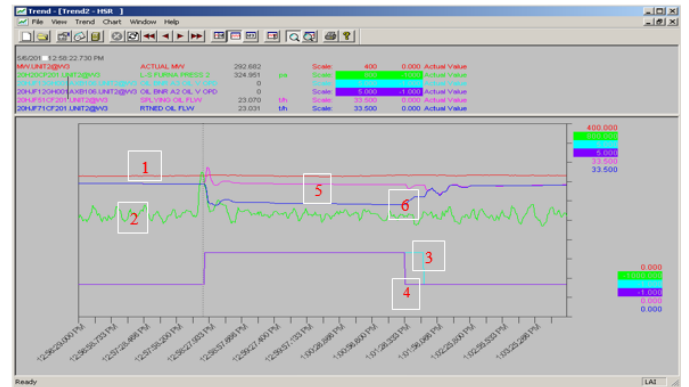

Fig. 8. Automatical opening of the oil valves when the furnace pressure more than +250pa

Figure 8 shows the unit load is 292 MW and the oscillations of furnace pressure is +324pa, satisfying the required conditions to automatically open two oil valves: A2 and A3. Thereafter, the corresponding A2 and A3 oil burners are burned to make the furnace pressure stable (line 2).

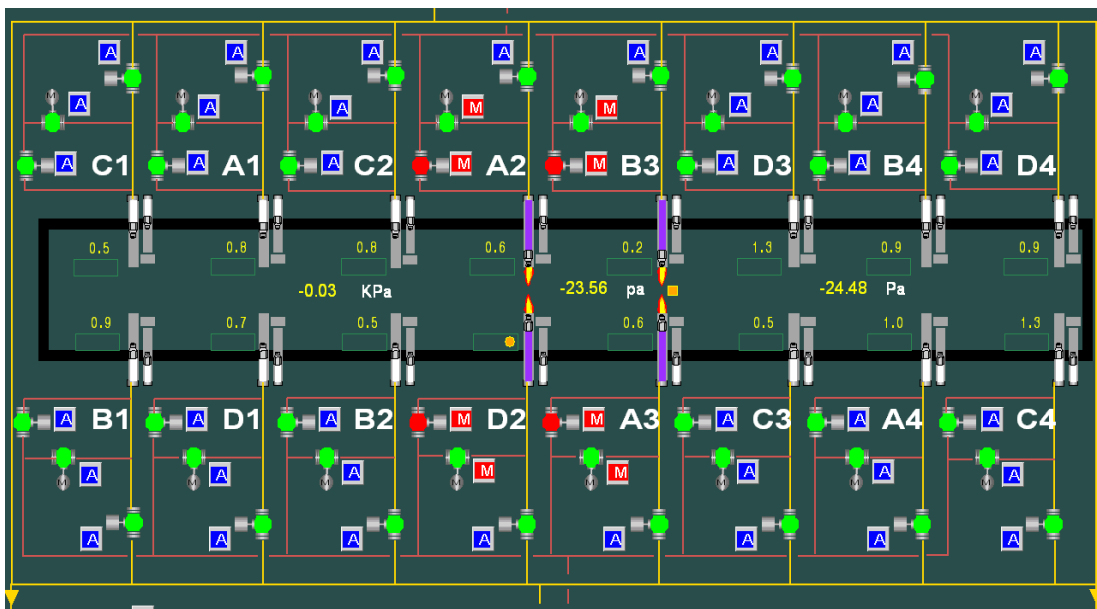

Fig. 6. Oil valves are taken into automatical mode

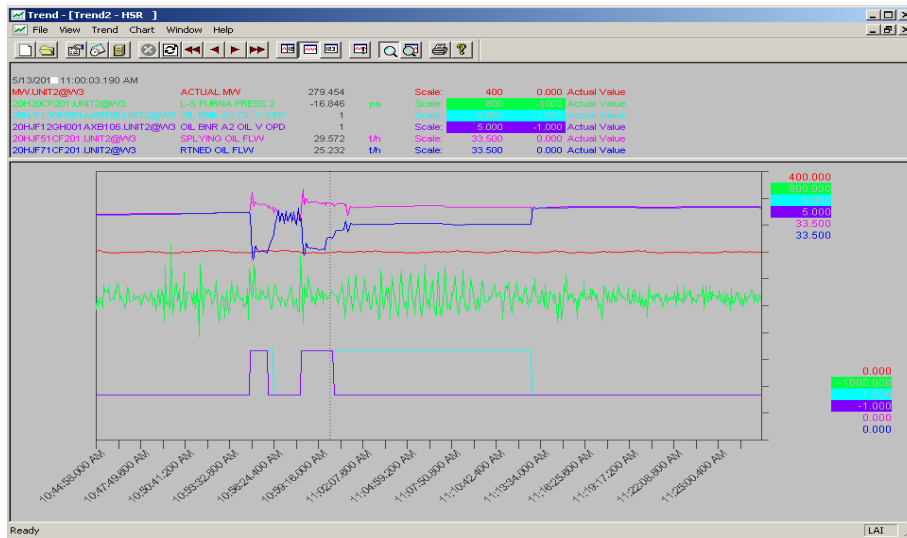

Fig. 9. Automatical opening of the oil valves when the the furnace pressure fluctuates

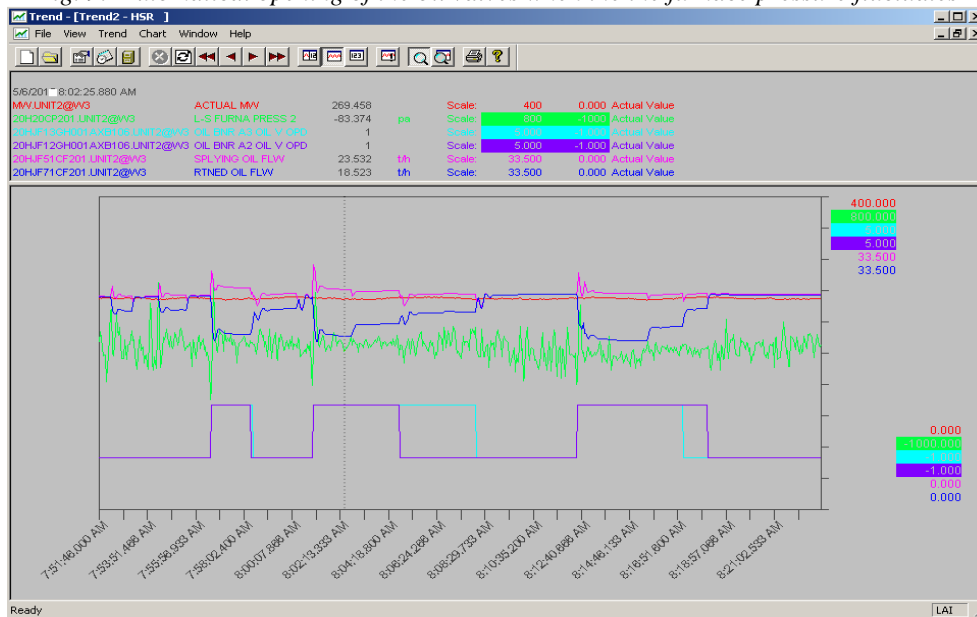

Fig. 10. Automatical opening of the oil valves auto open when the oscillations of furnace pressure (continued)

In the next two figures (Fig. 9 and Fig. 10), the control results are clearly presented. It is obvious from these figures, the oil valves are automatically opened when presenting the furnace pressure oscillations, and shortly the furnace pressures return to stability. Therefore, it can be said that the proposed control strategy regarding the improvement of the oil burner system for solving the problem of the furnace pressure oscillation is successful. The duration of the oil burner start-up sequence has been significantly reduced and the oil burner is automatically started for this phenomenon. The results obtained are good to ensure the stability of the plant (see Figs. 9 and 10).

4. Conclusion.

The practical control solution proposed in this paper in dealing with the oscillation problem of the furnace pressure has been successfully applied for a real thermal power plant in Vietnam. This kind of the pressure oscillation affects on the stability of the power plant since it is able to cause the shutdown of the burner. Therefore, an efficient control solution should be created to respond to this emergency. The proposed control scheme is to improve the oil burner system by means of an automatical start-up of the oil burners whenever the furnace pressures fluctuate over a high limit or under a low limit. The effectiveness of this control solution is to make the operation of the boiler

more stable and reliable, improving economic efficiency of the thermal power plant.

The proposed technical solution is an optimal control method, bringing a high efficiency for the control system embedded in the plant. The effectiveness of the method has been tested through actual operating process in the thermal power station. The results obtained are displayed directly on the monitor system for operating parameters of the unit. They verified an efficiently practical application of the proposed control strategy.

References

- [1] Oosthuizen, D.J., Craig, I.K., Pistorius, P.C.: Economic evaluation and design of an electric arc furnace controller based on economic objectives, *Control Engineering Practice*, Vol. 12, Iss. 3, p. 253-265, 2004.
- [2] Eremia, M. and Shahidehpour, M.: *Handbook of electrical power system dynamics: modeling, stability and control*, John Wiley & Sons, 2013.
- [3] Ali, A., Antonio, G. E.: *Power system state estimation: Theory and Implementation*, CRC Press, Mar 24, 2004.
- [4] Damian, F.: *Thermal Power Plant Simulation and Control*, IET, 2003.
- [5] Mania, P., Damien, E., and Daniel, R. V.: *Transient Stability of Power Systems: A Unified Approach to Assessment and Control*, Springer Science & Business Media, Dec 6, 2012.
- [6] Dipak, S.: *Thermal Power Plant: Design and Operation*, Elsevier, Aug 20, 2015.
- [7] Robin, A. C.: *Thermal Power Plants – Volume II*, EOLSS Publications, Nov 30, 2009.
- [8] Seikan, I.: *Steam Power Engineering: Thermal and Hydraulic Design Principles*, Cambridge University Press, 1999.
- [9] Shrikant, B.: *Condition Monitoring in Large Thermal Power Plants: Power Plant Condition Monitoring*, Notion Press, Sep 15, 2017.
- [10] Sadik, K.: *Boilers, Evaporators, and Condensers*, John Wiley & Sons, 1991.
- [11] Heimo, W., Bernd, E.: *Numerical Simulation of Power Plants and Firing Systems*, Springer, Apr. 18, 2017.
- [12] Alexander, S. K.; Rigkhat R. K.; Vitaly, V. G.; Maria S. G.; Ekaterina A. K.: Automated control of fuel burning in multi-port boiler of thermal power station, 2016 13th International Scientific-Technical Conference on Actual Problems of Electronics Instrument Engineering (APEIE), Vol. 3, p. 187-191, 2016.