

ROLE OF DUAL INPUT FUZZY CONTROLLER FOR THE BETTER PRODUCTION OF REAL POWER IN WIND SYSTEM

M. Rajvikram

Department of Electrical and Electronics Engineering,
Sri Venkateswara College of Engineering, Chennai, Tamilnadu - 602117, India
rajvikram@svce.ac.in

Abstract: *As non-renewable resources such as coal and tar are not only on the verge of depletion but also environmentally damaging, the world is looking towards alternative sources of energy that are environmentally and economically sustainable. Wind energy production has been growing at a rapid rate and has a promising outlook. It has come to play a vital part in supplying future energy needs. The work reported in this paper is about implementing the power maximization control technique towards the rectifier side. In order to attain this, grid-connected PMSG based WECS is scrutinized with one input fuzzy logic controller and modified fuzzy logic controller. The main focus of the research is to boost the power produced by the fuzzy one input controller applied towards the side of rectifier in tracking the uttermost power, where the uttermost power produced at several speeds of the wind is relatively low. A novel modified fuzzy logic controller towards the side of rectifier is implemented to bring out the uttermost power produced at several speeds of wind turbine. The analysis carried out in this work will help in the surge of power production routine of the PMSG using modified fuzzy logic controller compared to fuzzy one input MPPT controller. The simulation results are obtained by MATLAB software.*

Keywords: *Maximum Power Point Tracking (MPPT), Permanent Magnet Synchronous Generator, Wind Energy Conversion System (WECS), Modified Fuzzy Logic Controller, Wind turbine, DC link capacitor, Fuzzy Logic (One Input) Controller, Three phase grid.*

1. Introduction

The extraction of uttermost power in the wind system has been a major criteria to be taken in terms of design perspective. The design of the wind system to track the maximum power is completely dependent on the controller implementation. This section will bring out the effectiveness of the controllers in the process of maximum power tracking and also it will highlight the contributions of other researchers in this field.

The complete system Controller, Wind turbine, DC link capacitor, Fuzzy Logic (One Input) Controller, three phase grid that involves in conversion of the wind energy to electrical energy is called wind energy conversion system. A wind turbine generates the uttermost energy from the wind when it is running at favorable rotor speed. The best rotor speed varies due to varying nature

of wind speed.

The following paragraphs will elucidate the need for a MPPT controller in the grid connected WECS.

A nonlinear predictive control (NLPC) is used to adjust amplitude of rectifier voltage and stator current of PMSG in a wind energy conversion system. The control was implemented using Dspace DS1104 card and also the system was controlled in real time [1]. Several steps have been taken to eliminate the common traditional control techniques like DC link control, decoupled control of reactive power and converter complexities. A novel method has been analyzed and designed for distributing the real power uniformly to the grid-connected system; and stability considerations have also been mathematically modeled [2]. Maximum power point tracking using Fuzzy one input controller is designed to get the best real power output at the fixed speed of 12m/s is tested and the real power has the presence of more oscillations [3]. The synchronization of the wind system with respect to the grid is attained by means of PWM control technique [4].

Thorough evaluation has been made pertaining to the predictive model control and duty cycle modulation ratio of the rectifier side of the wind system. The field programmable gate array based programmable controller has been designed so as to improve the real power producing capability of the grid-connected wind system. There are several techniques implemented which have eliminated the need for a direct control of nonlinear system [5].

Superconducting Fault Current Limiter (SFCL) plays a vital role in suppressing the DC link voltage oscillations when the connection to grid through PMSG based wind system is subjected to fault. The severity of fault can be differentiated based on fault duration. If the fault cycle is more than 5, the system certainly needs a protective circuit. The wind system has the DC link capacitor which acts as a coupler between rectifier and inverter. Since the system is connected in series, when fault appears there is a high shoot up in the level of DC link voltage which affects the grid side converter. Hence, the peak shoot up is mitigated by means of SFCL [6].

The controller which reduces the resistance losses by keeping the generator quadrature axis current is discussed [7].

Grid voltage measurement methods have been put forward with respect to control of watt less power. The author has brought out the stability analysis methods with respect to the control of real power and reactive power. It emphasizes that when the frequency variations are reduced, real power is generated at an optimal rate to the grid. When the bus voltage magnitude is maintained constant, reactive power is maintained and supplied at an optimal rate.

The importance of PF and QV control loop is clearly explained [8].

The wind system performance is analyzed even under transient conditions. Authors have explained the protection methods to bring the system back to normal conditions from the abnormal grid fault conditions. In order to carry out this analysis, the grid side converter is implemented with sliding mode PI controller to protect the system from fault condition. The proofs were obtained by substantiating the sliding mode PI to be the best compared to the normal PI controller [9].

The direct power control technique has been applied in the rectifier side to improve the maximization of power and that the short circuit faults are predominant. Hence it is solved by means of the PI control technique [10].

The effect of fault current while extracting the power from the system is discussed [11].

The converter topologies design with respect to the matrix controller is thoroughly discussed [12].

The technique to mitigate the power oscillations is discussed [13].

Distribution function for wind scenario generation and compared the profit of renewable resources for coordinated operation and uncoordinated operation is proposed [14].

Wind turbine placement in a distribution market environment using PSO, considering social welfare as an objective for the first time is suggested [15].

Combined optimal allocation of solar plant and wind turbine by using PSO for the first time is suggested [16].

Amalgamation of economic and reliability considerations in placing DG units is proposed [17].

Hybrid optimization technique using Fuzzy-GA implemented for DG unit allocation that reduced the search space considerably is developed [18].

Various surveys have been made pertaining to the grid connected wind system with the focus more on the maximum power point tracking at various wind turbine speeds. In this research paper the traditional existing fuzzy one input MPPT controller is replaced by means of Modified two input fuzzy logic controller. The

simulated results will prove that the proposed modified fuzzy logic controller will produce more real power compared to the existing one input fuzzy logic controller.

2. Conceptual Method Representation

The conceptual representation of the methodology applied in the research is as shown in the Fig.1. In the rectifier side of the system, Modified fuzzy logic controller is applied to track the uttermost power at various speeds of wind turbine. It will also take care of generating the controlled quadrature axis current pulses to the IGBT switches used in the rectifier topology.

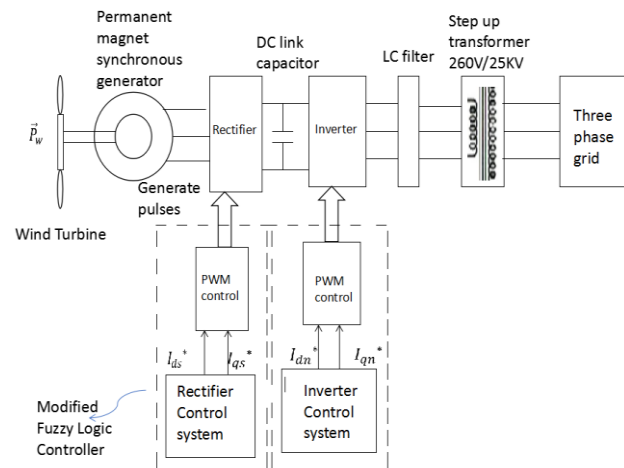

Fig.1. Representation of the Proposed Model

2.1 Design parameters of the PMSG based WECS

Table 1 and Table 2 describe the parameters involved in the design of wind turbine and the modeling of PMSG and other devices.

Table 1
Parameters of Wind turbine

Rating	1.5 MW
Blade radius	38m
Number of Blades	3
Air density	0.55kg/m ³
Rated wind speed	12 m/sec.

Table 2

Parameters of Wind Parameters of PMSG and other devices

Rating	1.75MVA
Rating of step up transformer	100kVA,260V/25Kv
Capacitive filter	10kVAr
Inductance(RL branch)	2.5000x10 ⁻⁴ H
Resistance(RL branch)	0.0019Ω

2.2. Rectifier side control system

Rectifier side controller system is divided into three sections as follows,

1. MPPT CONTROLLER
2. PID Controller for Comparison
3. Modified Fuzzy Logic Controller for setting the speed reference value.

3. Modeling of controller design

Fig.2 illustrates the block diagram and the control logic of the offered rectifier control system where ω_{rm} represents mechanical angular velocity of generator, I_{qs} represents quadrature axis stator current, P_m represents power produced mechanically by the wind turbine, Ψ_r represents rotor flux linkage, I_{ds} represents direct axis stator current and T_e represents electromagnetic torque. The generator's optimal speed is found by the proposed MPPT controller. Neglecting the effect of direct axis current which will pay way for the reduction in the ohmic losses. Unlike induction generator, there is no need of flux linkage estimation in permanent magnet synchronous generator.

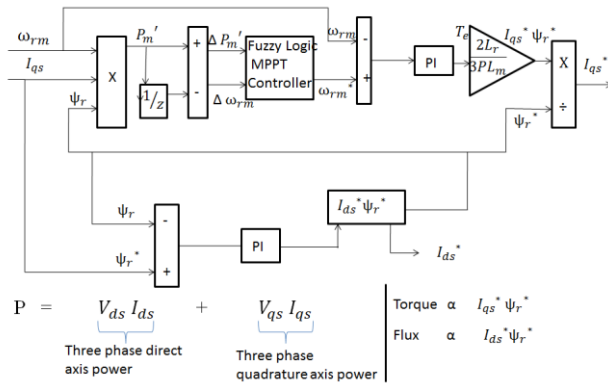

Fig. 2. Rectifier side torque control conceptual circuit of Modified Fuzzy logic controller

4. Methodology

Before entering into the main core area of grid integration and controller design aspects, all the basic analysis involved in designing each block and step by step realization are demonstrated in this section, including the controller design concept. Here the controller implemented towards the rectifier side is MPPT Controller. MPPT controller method is implemented by means of modified fuzzy logic controller.

4.1 Structure of Fuzzy controller Design

The design is implemented towards the rectifier side during ordinary running conditions of the grid to set the generator at an optimal speed. The fuzzy logic controller output generates the speed reference by means of change in mechanical power and different wind speed of the turbine as inputs. The controller is designed to extract the uttermost power during various wind turbine speeds.

Number of Inputs: 2

Number of Output: 1

Input 1: Change in wind turbine speed

Input 2: Change in mechanical power

Output: Speed Reference of the generator

5. Results and discussions

This section describes the simulation results of PMSG based wind system with the proposed modified fuzzy MPPT controller towards the rectifier side.

5.1 Power maximization control-analysis of PMSG based wind system throughout ordinary running conditions of the grid

The simulation outputs and waveforms obtained from Fig.4 to Fig.6 by the PMSG based wind energy conversion system with the proposed controller at the wind speed of 12m/s are shown. Fig.8 to Fig.9 explains the standard synchronized voltage and current waveforms at the wind speed of 12m/s, 15m/s and 18m/s. Fig.10 to Fig.12 explains the comparison graph showing the real power generated to the grid with the offered modified fuzzy logic controller at the wind speed of 12m/s, 15m/s and 18m/s respectively. Table 4 shows that the power generation is high when the wind turbine speed increases after the implementation of modified fuzzy based MPPT controller compared to the fuzzy one input controller and the significant results obtained by means of the proposed controller at the wind speed of 12, 15 and 18m/s are highlighted.

The graph shown in Fig.13, Reveals the power produced due to the PMSG without MPPT controller, with fuzzy one input MPPT controller and with modified fuzzy MPPT controller for each wind turbine speed and the variations are denoted.

5.2 Simulation conceptual diagram of grid-connected PMSG based WECS

The simulation diagram, as shown in Fig 3, is the main conceptual circuit where the wind system is coupled to the grid and the MPPT control strategy with the help of modified fuzzy controller implemented in the rectifier side and closed loop PWM control implemented in the inverter side.

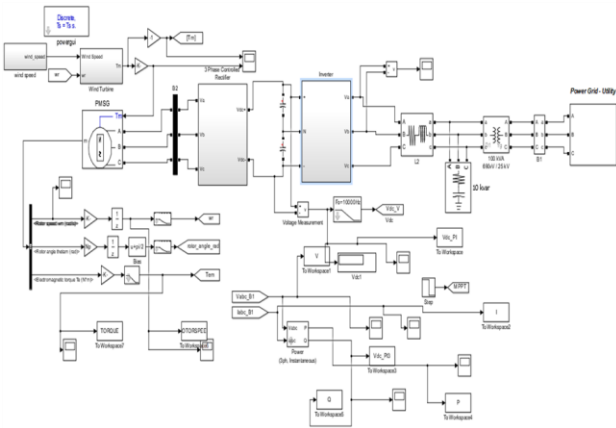

Fig. 3. Grid connected WECS simulation diagram

5.2.1 Rectifier control subsystem

Fig.3 is the most important circuit which gives the detailed explanation about the theme of the research pertaining to the grid-connected wind system since MPPT control is implemented on the rectifier control system with the help of fuzzy controller and PID controller. Two types of control are carried out:

1. Torque control
2. Current control

In Torque control, fuzzy logic controller compares the change in speed of wind turbine with the change in power and produces the speed reference to set the generator at an optimal speed to pursue the uttermost power; the PID controller compares the generator speed with the real speed and produces the speed error. The speed error decides what value of torque is to be given to the machine. In Current control, torque is converted into current, thereby after the desired parks transformation it is converted into voltage and the controlled firing pulses are sent through PWM generator to all the six MOSFETs.

5.3 Simulation outputs obtained by the PMSG based grid connected WECS

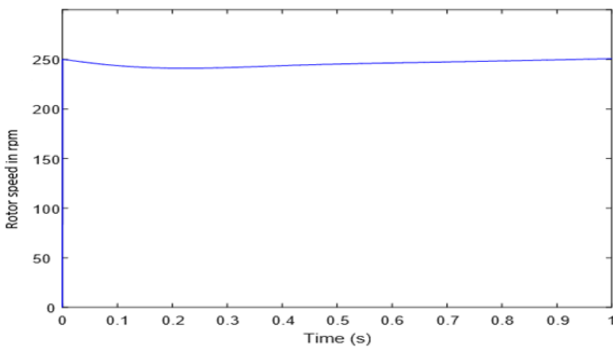

Fig. 4. Rotor speed

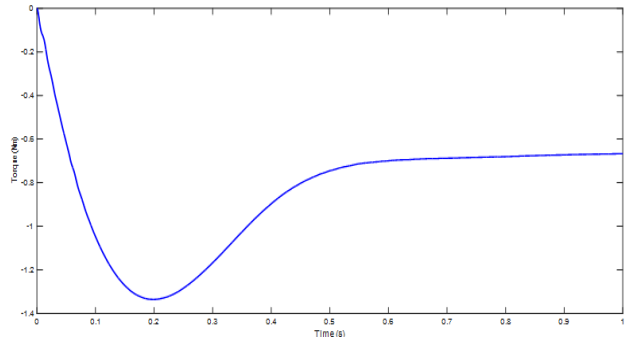

Fig. 5. Electromagnetic torque

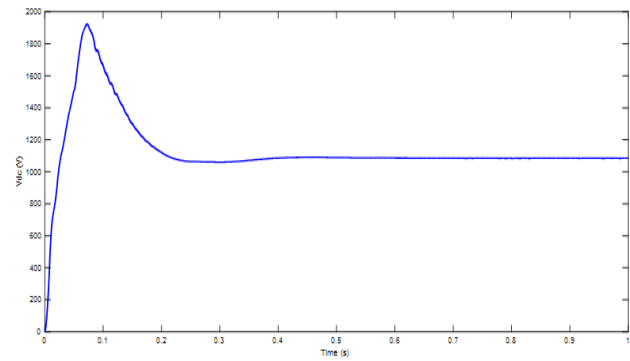

Fig. 6. Voltage across Dc link capacitor with modified fuzzy logic controller

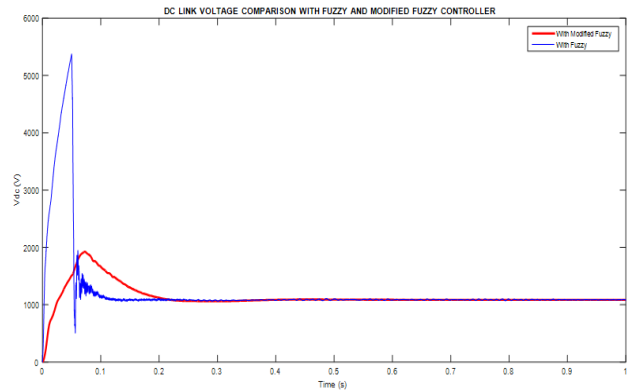

Fig. 7. DC link capacitor voltage obtained with Fuzzy and Modified Fuzzy based MPPT Controller

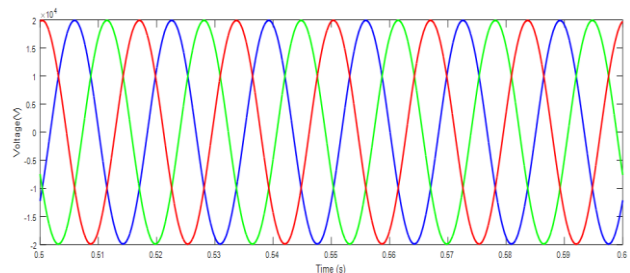

Fig. 8. Step up transformer output voltage waveform

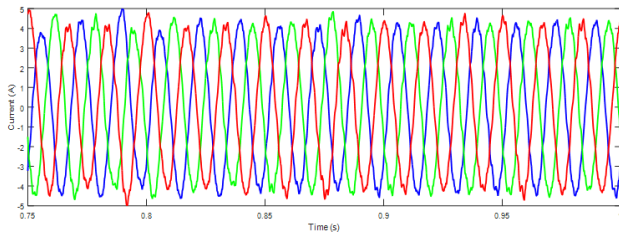

Fig. 9. Step up transformer output current waveform obtained at the speed of wind of 12m/s, 15m/s and 18m/s.

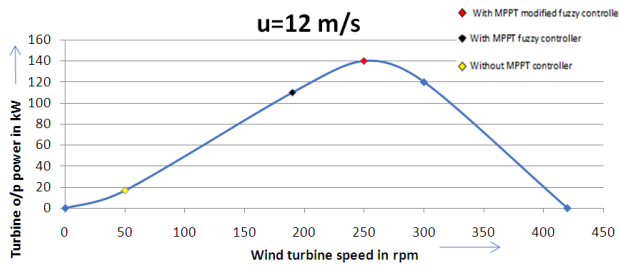

Fig. 10. Comparison Graph showing the Real power generated to the grid

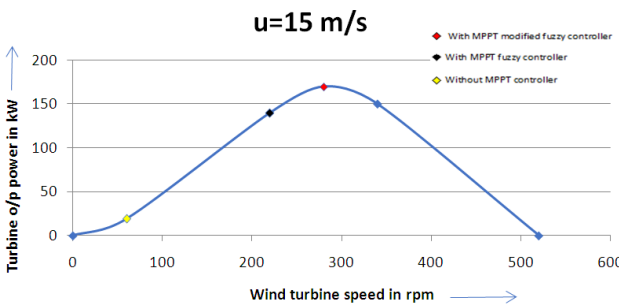

Fig. 11. Comparison Graph showing the Real power generated to the grid

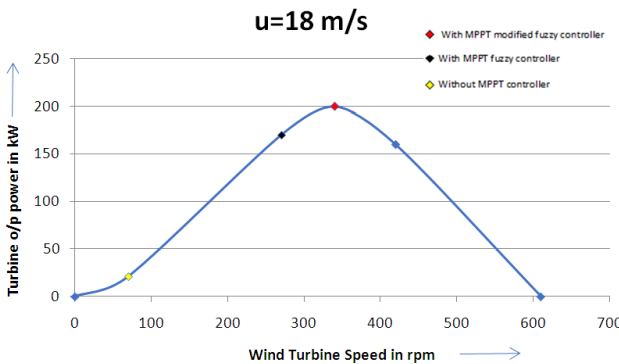

Fig.12. Comparison Graph showing the Real power generated to the grid

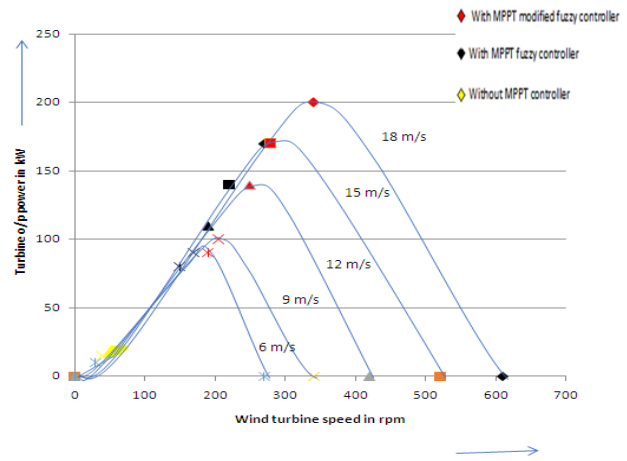

Fig. 13. Results of Maximum power point tracking with proposed modified fuzzy logic controller

Table 3
Results of proposed model PMSG based WECS

WIND SPEED (m/s)	WITHOUT MPPT CONTROLLER (Power in kW)	WITH FUZZY MPPT (ONE INPUT) CONTROLLER (Power in kW)	WITH MODIFIED FUZZY MPPT (TWO INPUT) CONTROLLER (Power in kW)
6	10	80	90
9	15	90	100
12	17	110	140
15	19	140	170
18	21	170	200

From Fig. 4, it can be inferred that the speed of rotor is around 1 p.u at the wind speed of 12m/s and it means that the PMSG is operating at synchronous speed and it supplies power to the grid. From Fig.5, It can be inferred that the electromagnetic torque is towards the negative region and the torque vale is -0.6 Nm. It proves that the permanent magnet synchronous generator is acting in generator mode and is supplying power to the three phase grid. Fig.6 indicates that the value of DC link voltage across the capacitor is 1900V, where the nominal DC link voltage is 1150V, and the safety factor of capacitor chosen for the research is 2.Hence the simulated output proves that the DC link voltage is within the stable limit with aid of modified fuzzy logic controller. Fig.7 shows that the proposed controller proves to be the best controller with effective output since with the aid of traditional fuzzy logic controller, the shoot up of DC link voltage is about 5500V and also it exceeds the safety factor of a capacitor. Whereas with

the proposed modified fuzzy logic controller, the shoot up in the level of DC link voltage is reduced to about 1900V and it is within the threshold limit. From Fig.8, it can be inferred that the output voltage of the step up transformer is 20 kV, and the waveform represents the perfect synchronization of the PMSG dependent grid-connected wind energy conversion system to the three phase grid of capacity 25kV at the wind speed of 12m/s,15m/s and 18m/s. Fig .8 to Fig.9 represents the synchronized current waveform with respect to the three phase grid at the wind speed of 12m/s,15m/s and 18m/s. Fig.10 to Fig.12 represents the comparison graph depicting the controller actions pertaining to the real power generated to the grid at the speed of wind of 12m/s,15m/s and 18m/s. Fig.10 to Fig.12 also explains that at the wind speed of 12m/s,15m/s and 18m/s, without MPPT Controller the real power generated to the grid is about 17kW,19kW and 21kW. It indicates that the real power generated to the grid with fuzzy one input MPPT controller is about 110kW, 140kW and 170kW.It also indicates that the real power generated to the grid with modified fuzzy logic controller is 140 kW, 170kW and 200 kW. The simulated curve obtained as shown in Fig.13 shows that there is effective improvement in the production of real power with the aid of proposed Modified MPPT fuzzy logic controller.

6. Conclusion

In this research work, the problems formerly faced by other researchers pertaining to the rectifier side control design have been rectified. Initially the rectifier side performance of the wind system is analyzed without a controller. The results pertaining to the real power produced by the system is very low. Further, the converter at rectifier side is invoked with fuzzy one input MPPT controller. The results are described based on real power value obtained by the system after the implementation of fuzzy logic controller is comparatively better than the system performance without a controller. It also leads to shoot up in the level of DC link voltage more than its threshold limit. This cannot be encouraged in a real time grid connected wind system. Hence it should be avoided. In order to overcome these mis happenings, Modified fuzzy logic controller is implemented towards the rectifier side converter. The novelty introduced in the work is the modification that is made in the existing fuzzy logic one input MPPT controller design, though the existing controller design gives better performance in terms of real power production. This technique not just reduced the DC link oscillations but further increased the

uttermost power produced at various speeds of wind turbine compared to fuzzy one input MPPT controller.

The real power produced at the particular wind speed and the improved efficiency of the proposed modified fuzzy logic controller is brought about clearly by means of the conceptual graph as shown in Fig.13. This simulated graph will clearly differentiate the performance of the proposed controller with that of the existing controllers. From the Table 3, it is concluded that the proposed modified fuzzy logic MPPT controller used in the rectifier control of a PMSG during normal operating conditions of the grid generates higher power as there occurs increment in wind turbine speed. Hence, PMSG is best suited for high wind speed application. The results obtained are fairly encouraging and it is proved to be more efficient.

7. Acknowledgement

The authors sincerely thank the management of Sri Venkateswara College of Engineering, Sriperumbudur Taluk, Chennai and Thiagarajar College of Engineering, Madurai, India for their support and guidance given in the completion of this research work.

References

- [1]. Aissou R, Rekioua T, Rekioua D and Tounzi A, *Robust nonlinear predictive control of permanent magnet synchronous generator turbine using Dspace hardware*, International Journal of Hydrogen Energy, Vol.41, No.45, 2016, pp.21047-21056.
- [2]. Qiang Wei, Bin Wu and Dewei Xu, *A Medium-Frequency Transformer-Based Wind Energy Conversion System Used for Current-Source Converter-Based Offshore Wind Farm*, IEEE Transactions on Power Electronics, Volume: 32, Issue: 1, January 2017.
- [3]. Rajvikram M, Renuga P and Swathisriranjani, *Fuzzy based MPPT controller's role in extraction of maximum power in wind energy conversion system*, IEEE International conference, 2016.
- [4]. Rajvikram.M and Renuga P, *stability analysis of grid connected PMSG based Wind Energy Conversion system using Matlab/Simulink*, IJERT, September 2016.
- [5]. Zhenbin Zhang, José Rodríguez and Ralph Kennel, *Advanced control strategies for direct-drive PMSG wind turbine systems: Direct predictive torque control approaches*, CPSS Transactions on Power Electronics and Applications, Vol.2, Issue.3, September 2017.
- [6]. Rajvikram M, Renuga P, Aravind Kumar G and Bavithra K, *Fault ride-through capability of permanent magnet synchronous generator based wind energy conversion system*, The Journal of CPRI, Vol. 12, No. 3, September 2016.
- [7]. Athanasios Mesemanolis, Christos Mademlis and

- Iordanis Kioskeridis, *High-Efficiency Control for a Wind Energy Conversion System With Induction Generator*, IEEE Transactions on Energy Conversion, Vol. 27, Issue.4, December 2012.
- [8]. Cheol-Hee Yoo, Il-Yop Chung, Hyun-Jae Yoo and Sung-Soo Hong, *A Grid Voltage Measurement Method for Wind Power Systems during Grid Fault Conditions*, Energies, Vol. 7, Issue.11, December 2014
- [9]. Adel Merabet, Khandker Tawfique and Rachid Beguenane, *Sliding mode speed control for wind energy conversion system*", IEEE 28TH Canadian Conference on Electrical and Computer Engineering (CCECE), September 2015
- [10]. Yerrami, Ouassaid and M Maaroufi, *Optimal Power Control Strategy of Maximizing Wind Energy Tracking and Different Operating Conditions for Permanent Magnet Synchronous Generator Wind Farm*, Elsevier Energy Procedia, Vol.74, Issue 12, August 2015.
- [11]. Abedini A and Nasiri, *PMSG Wind Turbine Performance Analysis During Short Circuit Fault*", Power Electronics and Motor Drive Laboratory, IEEE Canada Electrical Power Conference, 2012.
- [12]. M Aten, G Towers and C Whitley, *Reliability comparison of matrix and other converter topologies*, IEEE Transactions on Power Semiconductor Devices, Vol.12, Issue.7, September 2014.
- [13]. Akie Uehara, Alok Pratap and Naomitsu Urasaki, *A Coordinated Control Method to Smooth Wind Power Fluctuations of a PMSG-Based WECS*, IEEE Transactions On Energy Conversion, Vol.26, Issue.2, June 2011.
- [14]. Yajvender Pal Verma, Ashwani Kumar, *Economic-emission load dispatch in renewable integrated system under availability based tariff (ABT) environment*, Sustainable Energy Technologies and Assessments Vol.4, Issue.7, September 2013.
- [15]. Pierluigi Siano and Geev Mokryani, *Assessing Wind Turbines Placement in a Distribution Market Environment by using Particle Swarm Optimization*, IEEE Transactions on Power Systems, Vol.28, Issue.4, November 2013.
- [16]. Partha Kayal and C.K. Chanda, *Optimal mix of solar and wind distributed generations considering performance improvement of electrical distribution network*, Renewable Energy, Vol.75, Issue.12. March 2015.
- [17]. Neelakanteshwar Rao Battu, A.R. Abhyankar, Nilanjan Senroy, *DG Planning with Amalgamation of Economic and Reliability Considerations*, International Journal of Electrical Power & Energy Systems, Vol.73, Issue.10, December 2015.
- [18]. C.Nayanatara, J. Baskaran, D.P. Kothari, *Hybrid optimization implemented for distributed generation parameters in a power system network*, International Journal of Electrical Power & Energy Systems, Vol.78, Issue.6, June 2016.

About the authors

Mr. M. RAJVIKRAM received his B.E., in Electrical and Electronics Engineering from Anna University, Chennai in 2014. He is the best outgoing student and department topper in his undergraduation. He worked as an Associate Technical Operations at IBM Global Technology Services Division during 2014 – 2015. He completed his M.E., in Power System Engineering in the year 2017 from Thiagarajar College of Engineering, Madurai. He is the best outgoing student and gold medalist in his post graduation. He currently works as an Assistant Professor in Sri Venkateswara College of Engineering (Autonomous), Sriperumbudur. His areas of interest are Renewable Energy & Smart Grid, Wind Energy research, Power System Operation and Control, Converter Designs, and Artificial Intelligence Control Techniques. He has published papers in international journals, international and national conferences. He is a member of power and energy society in IEEE.