

# A REVIEW BASED ON SWITCHED RELUCTANCE MOTOR FOR EV AND HEV APPLICATIONS WITH SUITABLE CONVERTERS

**R. ELAVARASAN**

Research scholar, SELECT, VIT University Chennai  
Email: elavarasan.eee@gmail.com

**Dr. N. C. LENIN**

Associate Professor, SELECT, VIT University Chennai  
Email: nclenin@gmail.com

**Abstract:** This paper reviews the recent improvements in electric vehicle (EV). Now days, due to increase in usage of Internal Combustion (IC) engine vehicles, the atmospheric pollution raised hastily. The exhaust gas produced by the IC engine vehicles can be minimized by developing the hybrid electric vehicles (HEV). Based on various availabilities of special electrical machines, the Switched Reluctance Machine (SRM) is suitable for developing pollution free electric vehicle because of low cost and better efficiency. But, SRM has a drawback of torque ripple and acoustic noise; control this by selecting an optimized machine design and effective switching techniques.

**Key words:** finite element analysis, hybrid electric vehicles, switched reluctance machine, torque ripple, acoustic noise.

## 1. Introduction

Last few decades increase in usage of fuel, cost of fuel and air pollution. Now the research can focus on to electric vehicle with suitable electrical machine. There are various types of electric machines, out of that SRM are suitable based on performance, control and cost [1]-[5]. There were no permanent magnet can be used in SRM to get superior performance [6],[7]. In induction motor, synchronous motor and D.C motor, the winding can be present in rotor but SRM there is no winding as in fig.1.

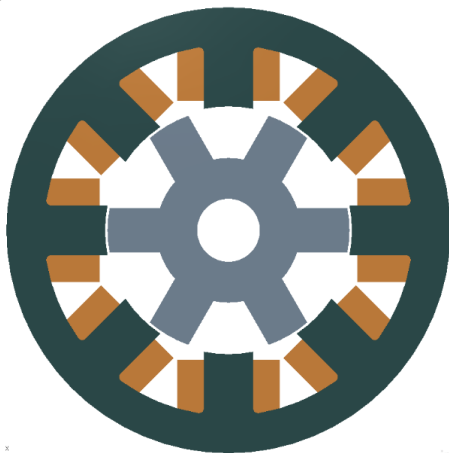

Fig. 1. 8/6 SRM model

The rotor weight can be reduced, minimized copper losses and thermal losses. Due to the absence of permanent magnet in SRM, it can suitable for the

application of hazardous environment, reduction of cost, maintenance free, and simple in structure. In SRM, even one of the phase winding get failure, the machine can continues to run with other phase windings by selecting proper switching sequence but it not applicable for other machines like induction motor, BLDC motor and synchronous motor.

## 2. Challenges

The machine used for hybrid electric vehicle has to fulfill the following constraint as dimension, weight, cost, efficiency, torque, acceleration, energy consumption, temperature, noise and vibration.

## 3. Development of SRM

### 3.1 Design Procedure

Basic structure of SRM as the stator has more number of poles than rotor poles, both are saliency. Only the stator has winding energized by proper switching sequence. There is no winding and no permanent magnet in the rotor. Always the stator pole arc must less than rotor pole arc [8],[9] for self starting.

### 3.2 Control Techniques

By selecting proper control switching method to minimise the torque pulsation, operating noise and improved performance in SRM. Various types of switching circuits as asymmetric bridge converter, bifilar type converter, C-dump converter and R-dump converter. MATLAB simulation modelling of various converter for three phase SRM as

#### 3.2.1 Asymmetric Bridge Converter

Asymmetric bridge converter as in fig.2, is used for high switching voltage to have fast developed of the excitation current. In [10] an electric motor drive fuel pump system has used high power density switched reluctance motors controlled by asymmetric bridge converter.

This type is suitable for very high speed operation of SRM drive because of the quick rise and fall times of current. In this circuit, the absence of additional resistance and coil, copper loss can be neglected. It has advantages of fault tolerance for the high reliability applications.

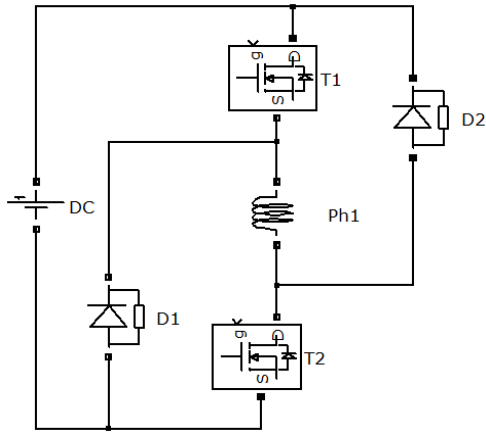

Fig. 2. Asymmetric Bridge Converter

In [11] asymmetric half bridge with single switch per phase can be used to reduce the cost and loss by less number of switches and the switching voltage should be twice the supply voltage.

### 3.2.3 C-Dump Converter

It has to consider a converter of additional voltage supply converter as in fig.3, because the stored energy of a excited phase is feed into dump capacitor in order to return the intermediate circuit or for directly magnetizing the next phase [12],[13].

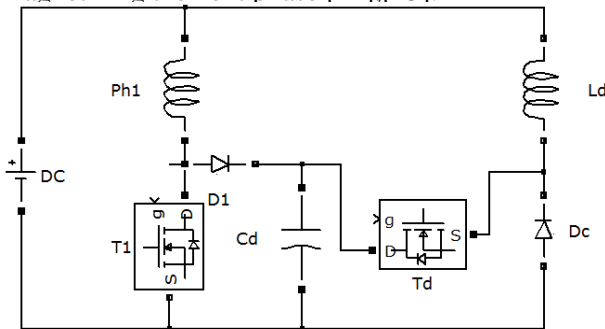

Fig. 3. C-Dump converter

### 3.2.4 Bifilar Winding Converter

This converter uses less number of switching devices thus reducing the cost. It allows fast demagnetization of phases during commutation. The Bifilar type converter dissipates some or all of the stored magnetic energy using external resistor, a phase resistor, or both. Then the remaining energy is transferred as mechanical energy. So, nothing from the stored magnetic energy in the phase winding is returned to the power supply or DC link capacitor. Bifilar type converter is shown in fig.4.

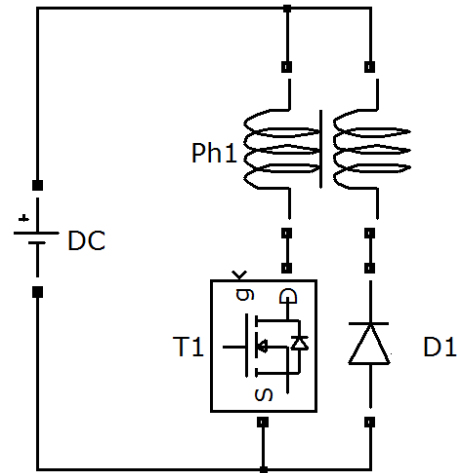

Fig. 4. Bifilar type converter

### 3.2.5 R-Dump Converter

It is one of the configurations which have one switch and one diode for every phase shown in fig.5. The value of resistance determines the switch voltage and also the power dissipation. While the switch is turned off, the current through diode, charging capacitor, and afterward flows through the external resistor. This resistor moderately dissipates the energy stored in the magnetized phase.

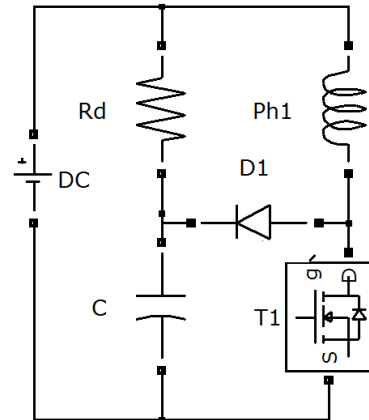

Fig. 5. R-dump converter

## 4. Advantages of SRM

### 4.1 Defect Tolerant

In an Induction Motor(IM), Direct Current (DC) motor and Synchronous motor distributed winding are made, if a particular group of coil get damaged then it affects the entire operation of machine. In [14]-[16], the stator of SRM has concentric winding arrangement, if any one of the phase winding get damaged the machine can continuous to operate by proper switching techniques and damaged phase winding cannot disturb the working of SRM. By making central tapping point in coil to identify and tolerate the fault easily [17].

Table I  
Comparisons of SRM and Induction Motors

Motor Specification	Oulton SRM	Induction Motor C			Induction Motor B High Efficiency
		Standard	E+II	E+III	
Frame	Cast Iron	Aluminium	Aluminium	Cast Iron	Cast Iron
Output power(hp)	10	10	10	10	10
Speed (rpm)	1800	1725	1750	1760	1760
Voltage (v)	460	460	460	460	460
Output torque (lb-ft)	29.19	29.96	30	29.9	30
Total volume (in <sup>3</sup> )	1307.37	1156.84	1260	1470	1518.5
Torque per unit volume (lb-ft/in <sup>3</sup> )	.0223	.026	.024	.024	.02
Total weight (lb)	169	103	123	190	172.5
Winding weight (lb)	17.66	10.23	11.8	13	23.77
Efficiency (%)	91.8	84.5	89.5	91	91.7
Temperature rise (measured)	60	104	-	-	62

#### 4.2 Materials and Temperature

No permanent magnet can be used in stator and rotor of SRM, the cost of the machine gets reduced. The winding can be wound around only in stator poles absence of winding in the rotor. The electrical losses can majorly occur only in stator core, the temperature of machine easily get dissipated. The salient pole rotor does not have windings, its weight and electrical loss get reduced [18], [19]. The temperature rise in rotor core is very low as compared to other machines, so no necessity of external cooling arrangement and windage loss reduced.

#### 4.3 Maintenance Free

Due to the absence of commutator, slip rings and brushes, the sparking over of brushes and commutator segment can be avoided. The overall size and weights of the machines get reduced. And also reduce the size of machine based on application requirement because no constraint for brush axis space. The periodic maintenances of SRM are reduced and it can be used for hazards environmental applications [20].

#### 4.4 Variable Speed

In [20], by selecting proper switching sequence, speed of SRM can be easily controlled. But in IM, DC motor and Synchronous motor needs additional control

units for setting the speed as required range.

#### 4.5 Accelerating Time

SRM can reach the rated speed faster than other motors like Induction motor and BLDC motor [3],[21].

#### 4.6 Cost

In [22], the manufacturing cost of SRM is low compared to induction motor because of no winding in the rotor, absence of permanent magnets, slip rings, commutator and brush arrangements.

#### 4.7 Comparison of SRM with other Motors

In [18] a 10 HP SRM compared with three different induction motors in table I, the result obtained as the SRM has produced minimum temperature because low electrical loss. The efficiency attain better in SRM as 7.3% greater at rated load and speed. The IM has windings in stator and rotor, rotor losses is addition to total loss of machine as in fig.6 but in SRM rotor loss will be low. As shown in fig.7, Permanent Magnet Brushless Direct Current Motor (PMBLDCM) has permanent magnet in the stator by replacing the filed winding in normal DC motor. Cost of permanent magnet should be high, overall cost of the machines get increase.

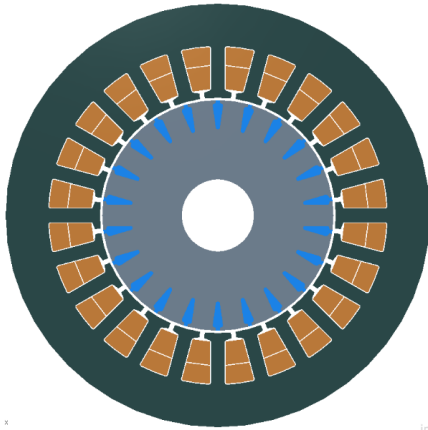

Fig.6. IM model

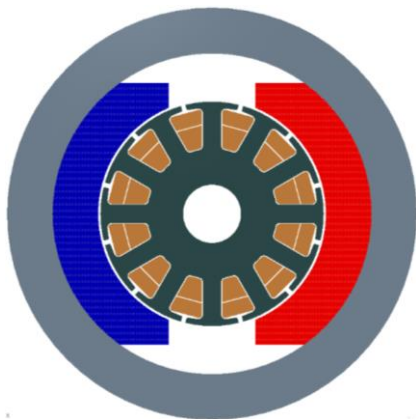

Fig.7. PMBLDCM model

But in SRM there is no permanent magnet usage, cost get decrease. The SRM attains better torque per unit volume, torque/inertia ratio and higher efficiency with induction motor [23], [24].

### 6. EV and HEV applications of SRM

SRM is highly suitable for automobile applications because of its simple structure, easy control, compact size and reduced cost [25], [26]. In [27], by using SRM in automobile applications, the complicated and large weight mechanical arrangement of IC engine drive can be replaced by simple electric drives.

Table II  
Comparison of different motors

	IM	SPM	IPM	SRM
Robustness	+			+
Motor cost	+			+
Efficiency		+	+	+
Open loop control	+		+	
Closed loop control		+		+
Torque smoothness	+		+	-
Wide speed range	+		+	+
Acoustic noise				-

The SRM has better performance in electric vehicle application compared with other machines as in table II. The Vision 200[19] has a series hybrid architecture as shown in fig.8. As it is a plug-in vehicle, the batteries can be charged from the electricity grid while parked as in fig.9. Alternatively an auxiliary power unit (APU) is integrated in the car for extending the range. Interchangeable APUs, e.g. hydrogen or bio-ethanol units, widen the undependability of the Vision 200.

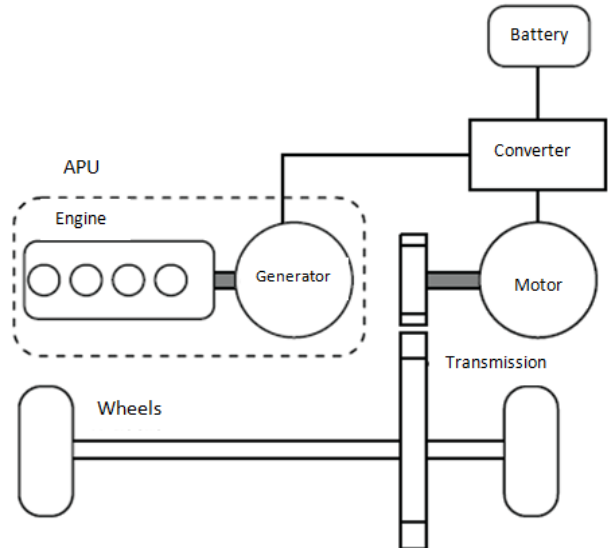

Fig.8 Hybrid Architecture



Fig.9. Plug-In Charging[6]

Normally the vehicles used for long distance travel, the temperature of the engine get increase and it can tolerate the suspension to road conditions. SRM is the best choice for withstanding high temperature and different operating situations [28]-[34]. Table III shows the comparison of different motors based on torque, power and speed.

Table III  
Performance of different motors

Motor	Torque density (Nm/Kg)	Power density (kW/Kg)	Maximum speed (rpm)
Induction	4	1.5	15000
PM	5	1	9000
SRM	4	1.5	20000

In ancient days, the SRM [35] has limited in electric vehicle applications because of torque pulsation, this can be overcome by designing modular SRM with E-shape stator core and three segmental rotor poles. And also by making optimized structure of stator and rotor poles to improve the performance [36]. In [37], make the modification in stator core as C-shape and produce the axial flux to reduce the radial flux fringing with improved performance suitable for electric vehicle applications.

In [38]-[39], SRM consume low power in electric vehicle applications. Cost of material for SRM is also low compare to interior permanent magnet synchronous machine (IPMSM) as in fig.10.

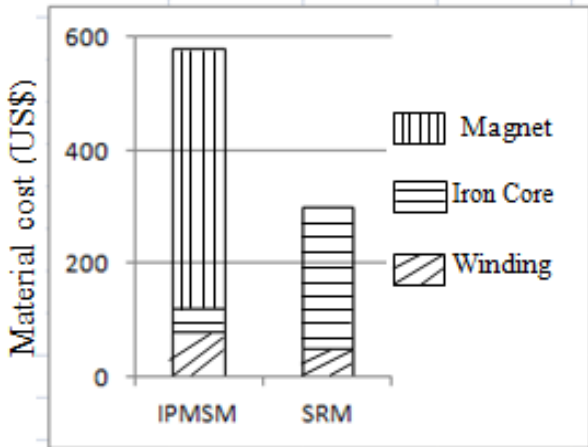

Fig. 10 Cost analysis for different motors

By conducting suitable load test on SRM to obtain the efficiency and output power better than IPMSM for high speed EV applications [40]-[43]. The input power requirement of SRM can be supplied by battery through proper controller. Again the battery can be charged by using stator winding inductor with charging unit of less power switches. This leads reduce off-board charging stations and time for charging the electric vehicle batteries [44]-[45].

In [46] makes the double high frequency pulse with phase shift and large duty cycles are supplied to low switches in two phase excitation of SRM by proper

turn-on/off angle which is suitable for electric vehicle operations. In [47]-[48], SRM has been designed based on speed control and torque ripple minimization by using Proportional Integral(PI) controller and Fuzzy logic controller(FLC) with different converters. Among that FLC in table IV gives best output suitable for electric vehicle.

Table IV  
Torque Ripple by using PI and FLC

Controllers	Torque ripple obtained
PI	1.83
FLC	1.70

In [49]-[51], the SRM designed for HEV passenger bus application with improved performance at high speed. But for continuous load carrying, the temperature of the machine increase to prevent that by making proper cooling arrangement.

## 7. Conclusion

In this paper, it has been reviewed that the SRM can be compared with other types of motors based on cost, size, performance, maintenance, controllability and long life. SRM is the best choice for electric vehicle application with optimized design operated by suitable controller.

## References

1. D. M. Sugden, S. P. Randall, and P. D. Webster: "Low-Power Controlled-Speed Drives using SR Motors," in *IEEE Transactions*, 1987, pp.269-272.
2. T. J. E. Miller, P. G. Bower, R. Becerra, and M. Ehsani: "Four-Quadrant Brushless Motor Drive," in *IEEE Transactions*, 1988, pp.273-275.
3. Khwaja M. Rahman, Babak Fahimi, G. Suresh, Anandan Velayutham Rajarathnam, and M. Ehsani: "Advantages of Switched Reluctance Motor Applications to EV and HEV: Design and Control Issues," in *IEEE Industry Applications Magazine*, July/ Aug.2014, pp.12-20.
4. P. Andrada, M. Torrent, B. Blaque, and J. I. Perat: "Switched Reluctance Drives for Electric Vehicle Applications," in *RE & PQJ*, vol. 1, no. 1, April 2003, pp.311-317.
5. B. A. Kalan, H. C. Lovatt and G. Prout: "Voltage Control of Switched Reluctance Machines for Hybrid Electric Vehicles," in *IEEE Transactions*, 2002, pp.1656-1660.
6. Kyohei Kiyota, Hiroya Sugimoto, and Akira Chiba: "Comparing Electric Motors an Analysis Using Four Standard Driving Schedules," in *IEEE Transactions*



- on *Industry Applications Magazine*, vol.36, no. 1, Jan./Feb. 2000, pp.111-121.
7. Akira Chiba, Kyohei Kiyota, Nobukazu Hoshi, Masatsugu Takemoto, and Satoshi Ogasawara: "Development of a Rare-Earth-Free SR Motor with High Torque Density for Hybrid Vehicles," in *IEEE Transactions on Energy Conversion*, vol.30, no. 1, March 2015, pp.175-182.
  8. R. Krishnan, R. Arumugam, and James F. Lindsay: "Design Procedure for Switched Reluctance Motors," in *IEEE Transactions on Industry Applications*, vol.24, no. 3, May/June 1988, pp.456-461.
  9. R. Arumugam, J. F. Lindsay, and R. Krishnan: "Sensitivity of Pole Arc/Pole Pitch Ratio on Switched Reluctance Motor Performance," in *IEEE Transactions*, 1988, pp.50-54.
  10. Arthur V. Radun: "High-Power Density Switched Reluctance Motor Drive for Aerospace Applications," in *IEEE Transactions on Industry Applications*, vol.28, no. 1, Jan./Feb. 1992, pp.113-119.
  11. Charles Pollock and Barry W. Williams: "A Unipolar Converter for a Switched Reluctance Motor," in *IEEE Transactions*, 1988, pp.44-49.
  12. M. Asgar and E. Afjei: "A New Class of Resonant Discharge Drive Topology for Switched Reluctance Motor," in *Iranian Journal of Electrical & Electronic Engineering*, Vol. 5, No. 4, Dec. 2009, pp.261-269.
  13. Ahmet M. Hava, Vladimir Blasko, and Thomas A. Lipo: "A Modified C-Dump Converter for Variable-Reluctance Machines," in *IEEE Transactions on Industry Applications*, Vol. 28, no. 5, Sep./ Oct. 1992, pp.1017-1022.
  14. Charles M. Stephens: "Fault Detection and Management System for Fault-Tolerant Switched Reluctance Motor Drives," in *IEEE Transactions on Industry Applications*, vol.27, no. 6, Nov./Dec. 1991, pp.1098-1102.
  15. Charles M. Stephens: "Fault Detection and Management System for Fault Tolerant Switched Reluctance Motor Drives," in *IEEE Transactions*, 1984, pp.41-45.
  16. Berker Bilgin, Ali Emadi, and Mahesh Krishnamurthy: "Comprehensive Evaluation of the Dynamic Performance of a 6/10 SRM for Traction Application in PHEVs," in *IEEE Transactions on Industrial Electronics*, vol.60, no. 7, July 2013, pp.2564-2575.
  17. Yihua Hu, Chun Gan, Wenping Cao, Wuhua Li, and Stephen J. Finney: "Central-Tapped Node Linked Modular Fault-Tolerance Topology for SRM Applications," in *IEEE Transactions on Power Electronics*, vol.31, no. 2, Feb. 2016, pp.1541-1554.
  18. H. H. Moghbelli, G. E. Adams and R. G. Hoft: "Comparison of Theoretical and Experimental Performance of a 10-Hp Switched Reluctance Motor," in *IEEE Transactions*, 1989, pp.89-98.
  19. T. Nobels, Th. Gheysen, M. Vanhove and S. Stevens: "Design Considerations for a Plug-In Hybrid Car Electrical Motor," in *IEEE Transactions*, 2009, pp.755-759.
  20. N. N. Fulton, and P. Greenhough: "Switched Reluctance Drives for Applications in Hazardous Areas," in *IEEE Transactions*, 1984, pp.11-15.
  21. Fathy El Sayed ABDEL-KADER, Mohsen Z. ELSHERIF, Naser M.B. ABDEL-RAHIM, and Mohamed M. FATHY: "Control Methods of the Switched Reluctance Motor in Electric Vehicle during Acceleration," in *Leonardo Electronic Journal of Practices and Technologies*, Issue 20, June 2012, pp.127-146.
  22. Berker Bilgin, Ali Emadi, and Mahesh Krishnamurthy: "Comprehensive Evaluation of the Dynamic Performance of a 6/10 SRM for Traction Application in PHEVs," in *IEEE Transactions on Industrial Electronics*, vol.60, no. 7, July 2013, pp.2564-2575.
  23. M. R. Harris, and T. J. E. Miller: "Comparison of Design Performance Parameters in Switched Reluctance and Induction Motors," in *IEEE Transactions*, pp.303-307.
  24. Hassan Moghbelli, Gayle E. Adams and Richard G. Hoft: "Performance of a 10-Hp Switched Reluctance Motor and Comparison with Induction Motors," in *IEEE Transactions on Industry Applications*, vol.27, no. 3, May/June 1991, pp.531-538.
  25. Qianfan Zhang, Xiaofei Liu, Shumei Cui, Shuai Dong and Yifan Yu: "Hybrid Switched Reluctance Motor and Drives Applied on a Hybrid Electric Car," in *www.intechopen.com*, chapter 10, Sep.2011, pp.215-232.
  26. Siavash Sadeghi, Mojtaba Mirsalim and Arash Hassanpour Isfahani: "Dynamic Modeling and Simulation of a Switched Reluctance Motor in a Series Hybrid Electric Vehicle," in *Acta Polytechnica Hungarica*, vol. 7, no. 1, 2010, pp.51-71.
  27. M. Ehsani, I. Hussain, and K. R. Ramani: "Low

- Cost Sensorless Switched Reluctance Motor Drives for Automotive Applications,” in *IEEE Transactions*, 1984, pp.96-101.
28. Berker Bilgin and Ali Emadi: “Electric Motors in Electrified Transportation Development,” in *IEEE Power Electronics Magazine*, June 2014, pp.10-17.
  29. Akira Chiba, Yuichi Takano, Motoki Takeno, Takashi Imakawa, Nobukazu Hoshi, Masatsugu Takemoto, and Satoshi Ogasawara: “Torque Density and Efficiency Improvements of a Switched Reluctance Motor Without Rare-Earth Material for Hybrid Vehicles,” in *IEEE Transactions on Industry Applications*, vol.47, no. 3, May/June 2011, pp.1240-1246.
  30. Dr. Sab Safi: “Alternate Motor Technologies for Traction Drives of Hybrid and Electric Vehicles,” Eureka magazine.
  31. David G. Dorrell, Andrew M. Knight, Mircea Popescu, Lyndon Evans and David A. Staton: “Comparison of Different Motor Design Drives for Hybrid Electric Vehicles,” in *Energy Conversion Congress and Exposition (ECCE)*, Oct.2010.
  32. Adrian BALATANU and Leonard Marin FLOREA: “Comparison of Electric Motors used for Electric Vehicles Propulsion,” in *International Conference of Scientific Paper AFASES*, May 2013.
  33. A. Peniak, J. Makarovic, P. Rafajdus, and P. Dúbravka: “Optimization of Switched Reluctance Motor for Drive System in Automotive Applications,” in *International Journal of Mechanical, Aerospace, Industrial, Mechatronic and Manufacturing Engineering*, vol. 8, no. 9, 2014, pp.1554-1561.
  34. Saphir Faid, Patrick Debal, and Steven Bervoets: “Development of a Switched Reluctance Motor for Automotive Traction Applications,” in *The 25th World Battery, Hybrid and Fuel Cell Electric Vehicle Symposium & Exhibition*, Nov. 2010.
  35. Wen Ding, Yanfang Hu, and Luming Wu: “Analysis and Development of Novel Three-Phase Hybrid Magnetic Paths Switched Reluctance Motors Using Modular and Segmental Structures for EV Applications,” in *IEEE/ASME Transactions on Mechatronics*, vol.20, no. 5, Oct. 2015, pp.2437-2451.
  36. W Wu, H C Lovatt, and J B Dunlop: “Optimisation of Switched Reluctance Motors for Hybrid Electric Vehicles,” in *Conference on Power Electronics, Machines and Drives*, April 2002, pp.177-82.
  37. Anas Labak, and Narayan C. Kar: “Designing and Prototyping a Novel Five-Phase Pancake-Shaped Axial-Flux SRM for Electric Vehicle Application Through Dynamic FEA Incorporating Flux-Tube Modeling,” in *IEEE Transactions on Industry Applications*, vol.49, no. 3, May/June 2013, pp.1276-1228.
  38. Kyohei Kiyota, Hiroya Sugimoto, and Akira Chiba: “Comparing Electric Motors an Analysis Using Four Standard Driving Schedules,” in *IEEE Transactions on Industry Applications*, vol.36, no. 1, Jan./Feb. 2000, pp.111-121.
  39. James D. Widmer, Richard Martin and Mohammed Kimiabeigi: “Electric vehicle traction motors without rare earth magnets”, 2015, pp. 7-13.
  40. Kyohei Kiyota, Takeo Kakishima, and Akira Chiba: “Comparison of Test Result and Design Stage Prediction of Switched Reluctance Motor Competitive With 60-kW Rare-Earth PM,” in *IEEE Transactions on Industrial Electronics*, vol.61, no. 10, Oct. 2014, pp.5712-5721.
  41. Kyohei Kiyota, Takeo Kakishima, Hiroya Sugimoto and Akira Chiba: “Comparison of Test Result and 3D-FEM Analysis at the Knee Point of a 60 kW SRM for a HEV,” in *IEEE Transactions on Magnetics*, vol.49, no. 5, May 2013, pp.2291-2294.
  42. Kyohei Kiyota, and Akira Chiba: “Design of Switched Reluctance Motor Competitive to 60-kW IPMSM in Third-Generation Hybrid Electric Vehicle,” in *IEEE Transactions on Industry Applications*, vol.48, no. 6, Nov./Dec. 2012, pp.2303-2309.
  43. Motoki Takeno, Akira Chiba, Nobukazu Hoshi, Satoshi Ogasawara, Masatsugu Takemoto, and M. Azizur Rahman: “Test Results and Torque Improvement of the 50-kW Switched Reluctance Motor Designed for Hybrid Electric Vehicles,” in *IEEE Transactions on Industry Applications*, vol.48, no. 4, July/Aug. 2012, pp.1327-1334.
  44. Yihua Hu, Xueguan Song, Wenping Cao, and Bing Ji: “New SR Drive With Integrated Charging Capacity for Plug-In Hybrid Electric Vehicles (PHEVs),” in *IEEE Transactions on Industrial Electronics*, vol.61, no. 10, Oct. 2014, pp.5722-5731.
  45. Yihua Hu, Chun Gan, Wenping Cao, Chushan Li, and Stephen J. Finney: “Split Converter-Fed SRM Drive for Flexible Charging in EV/HEV Applications,” in *IEEE Transactions on Industrial Electronics*, vol.62, no. 10, Oct. 2015, pp.6085-6095.
  46. Chun Gan, Jianhua Wu, Shiyong Yang, and Yihua

- Hu: "Phase Current Reconstruction of Switched Reluctance Motors From DC-Link Current Under Double High-Frequency Pulses Injection," in *IEEE Transactions on Industrial Electronics*, vol.62, no. 5, May 2015, pp.3265-3276.
47. Rahul D. Patil and Bindu R.: "Modelling and Control of Switched Reluctance Motor for Hybrid Electric Vehicle," in *International Journal of Advance Electrical and Electronics Engineering*, vol. 4, no. 2, 2015, pp.38-43.
48. Aarim C. Sijini, E. Fantin and L. Prakash Ranjit: "Switched Reluctance Motor for Hybrid Electric Vehicle," in *Middle-East Journal of Scientific Research*, vol. 24, no. 3, 2016, pp.734-739.
49. Zhan Qionghua, Wang Shuanghong, Ma Zhiyuan, Guo Wei, and Qiu Yihui: "Design of a 50kW Switched Reluctance Machine for HEV Propulsion System," in *IEEE Transactions*, 2003, pp.3207-3211.
50. Khwaja M. Rahman, and Steven E. Schulz: "Design of High Efficiency and High Density Switched Reluctance Motor for Vehicle Propulsion," in *IEEE Transactions*, 2001, pp.2104-2110.
51. Khwaja M. Rahman, and Steven E. Schulz: "Design of High-Efficiency and High-Torque-Density Switched Reluctance Motor for Vehicle Propulsion," in *IEEE Transactions on Industry Applications*, vol.38, no. 6, Nov./Dec. 2002, pp.1500-1507.