

MULTILEVEL CONVERTER FOR POWER QUALITY IMPROVEMENT

N.Pandiselvi V.Sureshkumar

Thiagarajar College of Engineering, Department of Electrical and Electronics Engineering,
Madurai, Tamil Nadu, India, 625 015, pselvieee@gmail.com

Abstract: *Today electric power is viewed as a product with certain characteristics which can be measured, predicted, guaranteed, improved etc. So power quality issues have become a major concern for all. In this paper the proposed topology is shown to possess a multilevel converter (ML) with seven level cascaded H bridges (CHB). This converter has been used in a Dynamic Voltage Restorer (DVR), a custom power device for power quality improvement. A three phase single pole seven level converter is designed and controlled using Synchronous Reference Frame (SRF) Theory. The SRF theory uses ABC to DQO transformation to calculate the required compensation voltage. The performance of suggested converter and switching algorithm are validated with simulation. The multilevel inverter injects the voltage and improves the efficiency of the algorithm and mitigating the voltage swell and sag performances are analyzed by MATLAB/SIMULINK software.*

Key words: *DVR, Multilevel Inverter, voltage sag, swell, SRF*

1. Introduction

In recent years, the major issues are power quality in electricity customers at various loads. The issues are illustrating by changes in frequency, variations in voltage or current those results in failure of customer equipment". The development of power electronic devices it is depends upon the serious impact on power quality of electric supply. The switch mode power supplies, dimmers, current regulator, frequency converters, low power consumption lamps, arc welding machines, etc. are some out of the many vast applications of power electronics based devices. The operation of these loads/ equipment generates harmonics and thus, pollutes the modern distribution system.

Now days in power network is increasing with nonlinear loads and Power quality enhancement. Power quality issues are voltage sag, swell and imbalance are affected by both consumers and industries [1-3]. The DVR is made of three unit: Voltage source inverter with dc supply and three phase series transformer [4]. The problem of sags and swell is occur on nonlinear loads, to rectify this issues by using of DVR. The two -level inverter and filter is constructed with high switching

frequency presented [6].

The injecting voltage is injects by three phase series transformer or three single phase transformer with the grid side. The purposes of the filter are removing ripples and inject the voltage to the transformer. The RLC filter is used to eliminate the switching frequency. By using of multilevel inverter it control the output voltage with phase angle, frequency, active and reactive power for the distribution network [7].

Dc bus voltage is get reduces with connection of series inductor as well as it boosted the voltage at load side. But it is not suitable for the cost and economical strategy [8].

The multilevel inverter is connected with photovoltaic grid system to improve the power quality and also compensate the voltage of three phase LLL-G fault, five and nine level topology of Cascaded bridge level is proposed and also is used to reduces the higher order harmonics.[9-10].

This paper introduces three single-pole 7 level H bridge multilevel inverter is proposed with SRF control algorithm for voltage sag and swell conditions. The phase shift multicarrier signal control the gating signal for the multilevel voltage source inverter. The results are obtained by the MATLAB/SIMULINK software.

2. DVR Proposed System

The multilevel inverter is incorporated with different level of AC output voltage waveform. The DVR based multilevel inverter is connected series otherwise shunt to the solar energy renewable energy or non linear load with dc source or batteries. The traditional system of DVR as shown in fig 1. The proposed system consists of the DVR with a multilevel inverter as shown in Fig.2. The three single- pole multilevel inverter is connected to the non linear load by neutral point.

The DVR is consists of voltage source inverter based multilevel, filter and three phase series transformer. By using of this approach does not require the segregated sources of individual phase. The

multilevel inverter occupies the number of semiconductor devices. The voltage levels are depends upon the semiconductor devices. In this paper propose the phase shifted multicarrier pulse width modulation technique is following sections.

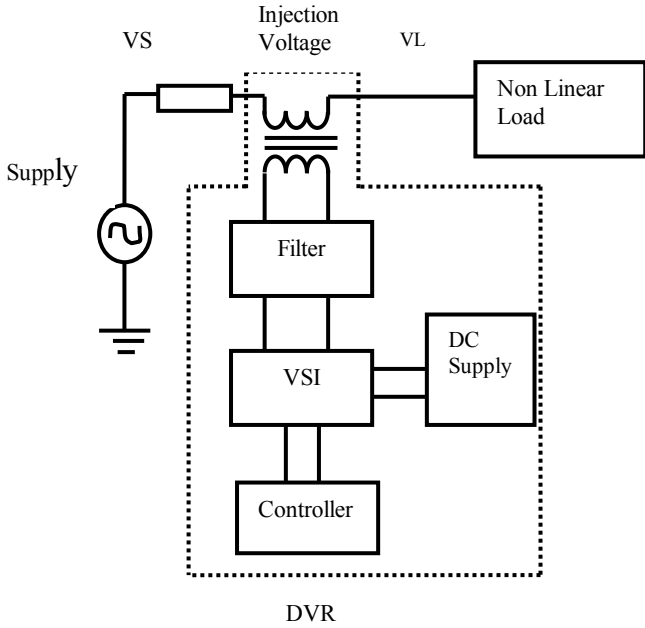

Fig. 1 Traditional DVR System

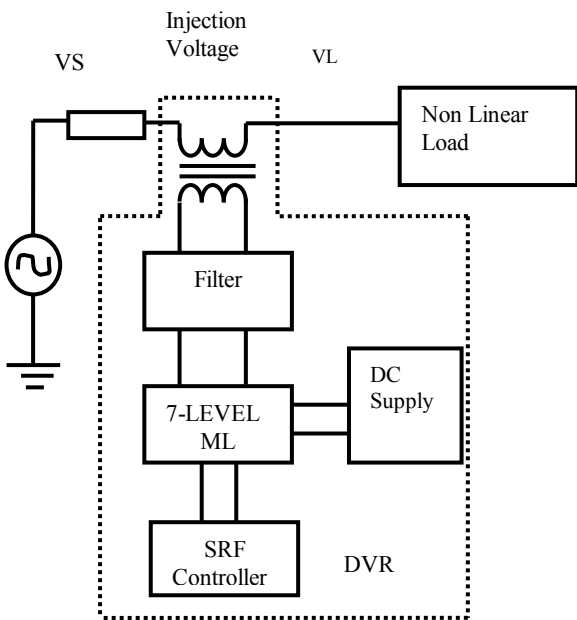

Fig.2 Traditional DVR System

The multilevel inverter cascaded bridges are simulated to compensate for power quality issues [6].

3. SRF CONTROL ALGORITHM

Synchronous Reference Frame controller is used for the control of the multilevel based Dynamic Voltage Restorer. This algorithm is suitable for the mitigation of power quality problems from the instantaneous voltage transformed from abc frame to dq0 coordinates.

Thus, the generation of gating pluses for three phase three wire system based DVR is discussed in the following sections.

$$V_d = \frac{2}{3} \left[V_{La} \times \sin(\omega t) + V_{Lb} \times \sin\left(\omega t - 2\frac{\pi}{3}\right) + V_{Lc} \sin\left(\omega t + 2\frac{\pi}{3}\right) \right] \rightarrow (1)$$

$$V_q = \frac{2}{3} \left[V_{La} \times \cos(\omega t) + V_{Lb} \times \cos\left(\omega t - 2\frac{\pi}{3}\right) + V_{Lc} \cos\left(\omega t + 2\frac{\pi}{3}\right) \right] \rightarrow (2)$$

$$V_0 = \frac{1}{3} [V_{La} + V_{Lb} + V_{Lc}] \rightarrow (3)$$

$$V_{La} = [V_d \times \sin(\omega t) + V_q \times \cos(\omega t) V_0] \rightarrow (4)$$

$$V_{Lb} = [V_d \times \sin\left(\omega t - 2\frac{\pi}{3}\right) + V_q \times \cos\left(\omega t - 2\frac{\pi}{3}\right) V_0] \rightarrow (5)$$

$$V_{Lc} = [V_d \times \sin\left(\omega t + 2\frac{\pi}{3}\right) + V_q \times \cos\left(\omega t + 2\frac{\pi}{3}\right) V_0] \rightarrow (6)$$

The three phase source side voltage and load side voltage as a given supply for the SRF controller for generate the reference signals for multilevel based DVR.

The instantaneous source voltage and along with abc coordinates is convert into dqo frame. The V_0 is zero axis, V_d is d-axis and V_q is q axis are calculated at point of common coupling from. The source voltage is in built with phase lock loop of the controller.

The SRF controller estimates with the reference signal through the positive sequence source and load voltage. The conversion of the abc into dqo coordinates is carried out by the transformation matrix as presented in following equation (1-6).

The V_{La}, V_{Lb}, V_{Lc} are sensed voltage is compared with reference voltage with phase shift multicarrier pulse width modulation (PSMPWM) signals to generate the insulated gate bipolar transistor [IGBT] switching signals. [11]

The SRF algorithm based DVR are to compensate the power quality problems like voltage sag ,voltage swell, voltage flicker, voltage interruption, voltage imbalance and unbalance.

4. Simulation Results and discussion

4.1 Cascaded H –Bridge Inverter

The one leg of a single pole H-Bridge converter which have DC voltage source and four Insulated Gate Bipolar Transistor(IGBT) namely, IGBT1, IGBT2, IGBT3, IGBT4.

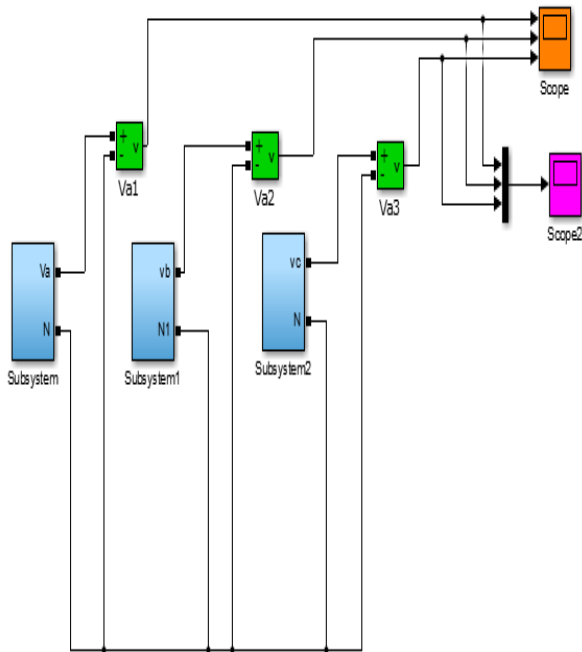

Fig.3 simulation diagram of three single pole 7-level H bridge inverter

The Three single pole Converter coupled together to form a three phase Converter. Phase shift for each phase is calculated and then the three phase output us obtained as shown in Fig.3.The cascaded h bridge inverter design is the four switch arrangement.

The multilevel inverter is connected to the ac output using arrangement of IGBT switches. The output voltage levels are in three phase $+V_{dc}, -V_{dc}, 0$. To achieve $+V_{dc}$, IGBT 1 and IGBT 4 are on condition, while $-V_{dc}$ to attain IGBT 2 and IGBT 3 are in on condition.

Finally switch on IGBT 1and 2 or IGBT 3 and 4, output voltage is 0.The cascaded inverter bridge have N input sources and maintain the $(2N+1)$ levels to desire the AC voltage output.[7]

From fig.4 shows the diagram of a single pole – H bridge Converter made of three separate legs. Each leg of the converter consists of four IGBT switches closed with a resistor as filter and DC voltage source.Total voltage for the single pole Converter is 300 Volts.

The 12 IGBTs of each phase must be triggered at appropriate intervals to obtain the output. The IGBT Switches are triggered using multicarrier based on phase shifting pulse width modulation (PSPWM).

This is achieved by obtaining 6 carrier waves generated by repeating sequence blocks and one fundamental sine wave.Fig .5 shows the Simulink model for generating the carrier signal.

Fig 5 & 6 shows the carrier signal for the gating of IGBTs used in the inverter. There are six triangular wave and one sine wave for obtaining seven levels. This pattern is obtained by using six repeating sequences and one sine wave block by using of phase shift multicarrier pluse width modulation controller.

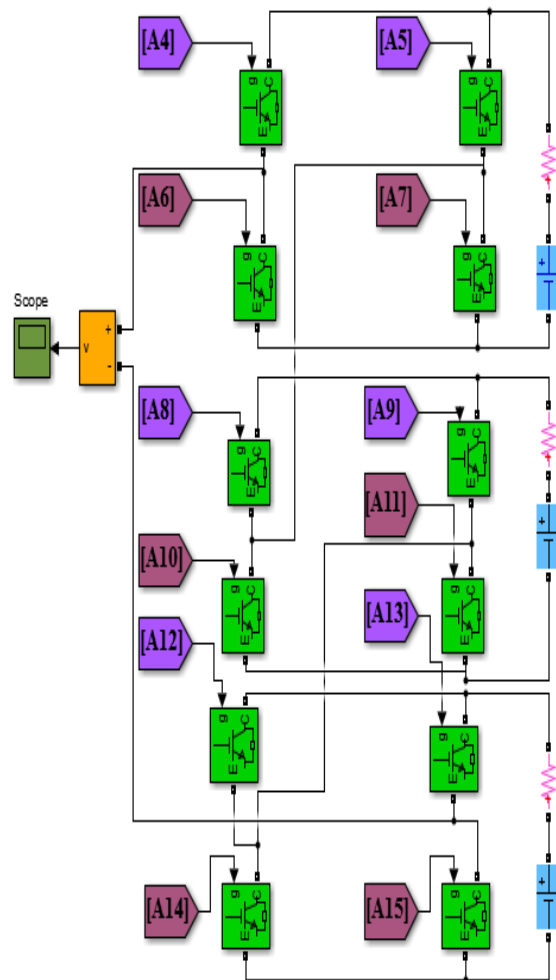

Fig.4 simulation diagram of single pole 7-level H bridge inverter

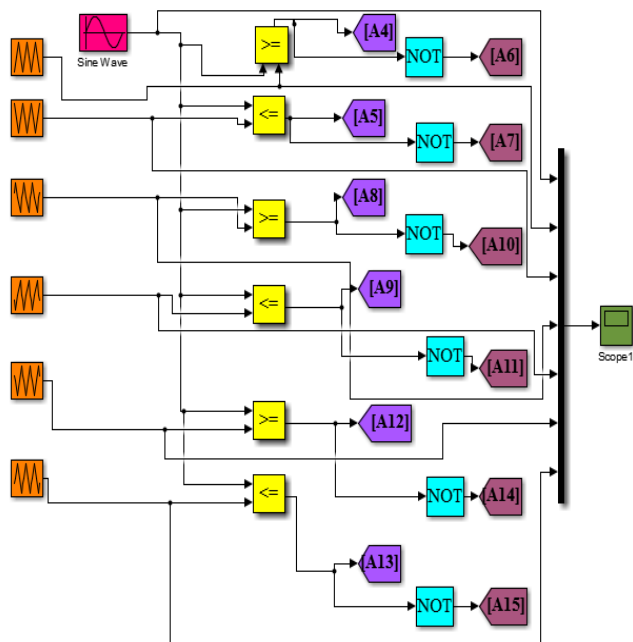

Fig.5 simulation diagram of Phase Shift Pulse Width Modulation

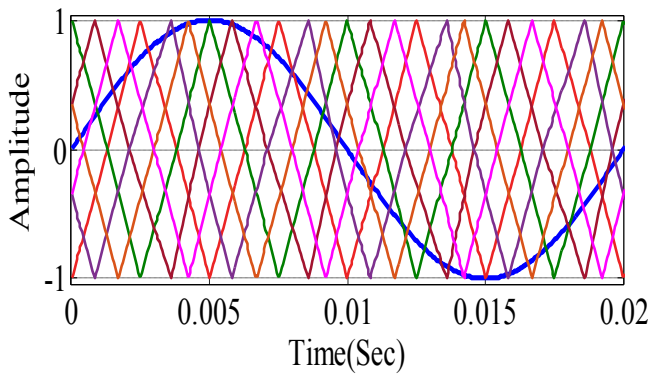

Fig.6 Phase Shift Multicarrier signal

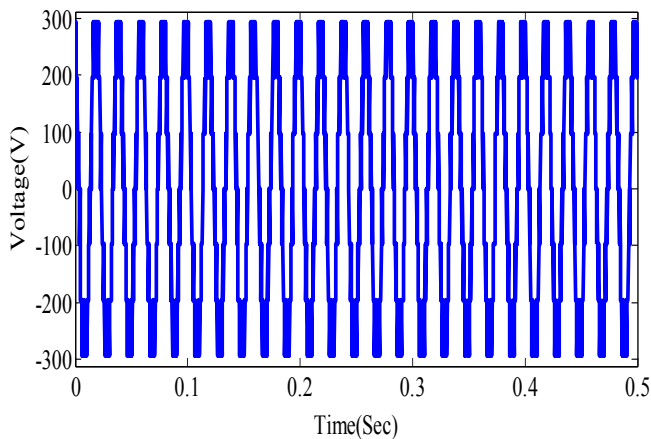

Fig.7 single pole 7-level H bridge inverter output

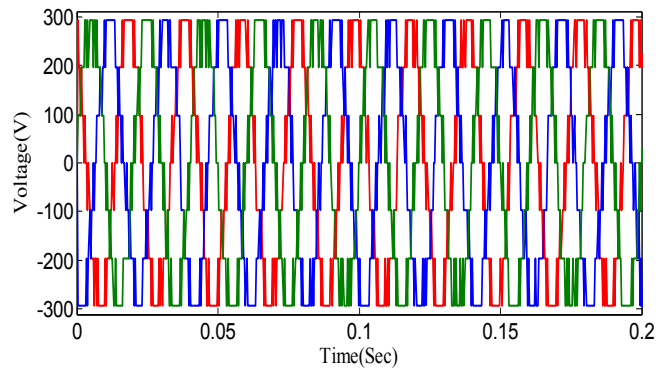

Fig.8 3Single pole 7-level H bridge inverter output

Fig 7 & 8 shows the output of 3 phase seven level inverter in which x-axis and y-axis denotes time and voltage respectively. Each phase having an amplitude of 300V.

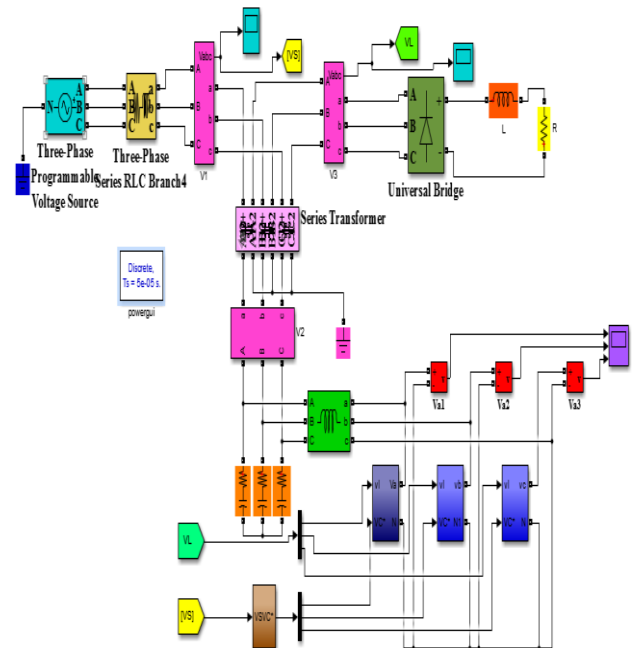

Fig.9 Simulation Diagram of DVR Based 7-level H bridge multilevel inverter

The test system's output confirms that the SRF algorithm is able to compensate both voltage sag and voltage swell. Thus, the SRF algorithm can be implemented in the DVR along with the three phase Multilevel Converter. The transformer of the DVR is tuned to match the multilevel converter. Fig 9 shows a system having a DVR with seven level inverter which uses transformer and Synchronous reference frame theory to compensate for both voltage sag and swell.

TABLE.1 System Parameters

System	Values
Grid Voltage	415 V,50Hz
Feeder Impedance	R = 0.1 Ω , L = 0.001 mh
Non linear Load	R = 8 Ω , L = 0.05mH
VSI parameters	Vdc = 100 V, C = 114 μ F, L=0.99mH R = 3.5 Ω
Transformer	36 KVA

The Table.1 shows the ratings of proposed DVR having a seven level inverter. The Phase shift multicarrier pulse width modulation controller is a rapid switching with speed. The structure is smooth and have excellent feedback. The efficiency of the multilevel inverter based DVR is enhance by tremendous switching frequency along with reduces losses in switching.

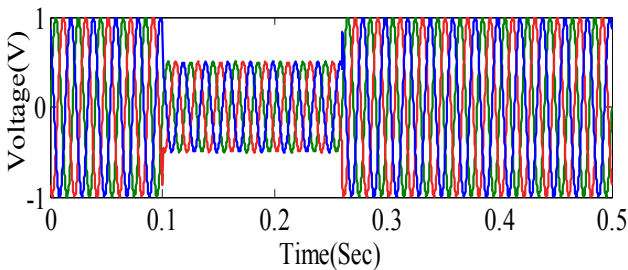

Fig.10 Source Voltage sag

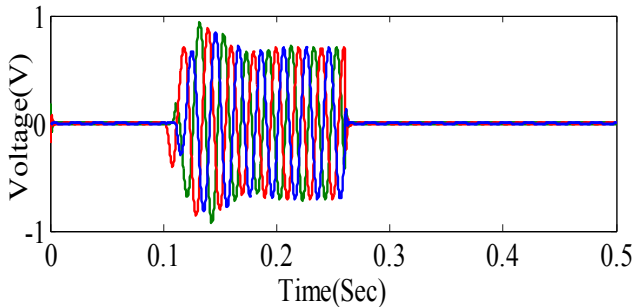

Fig.11 Injection Voltage

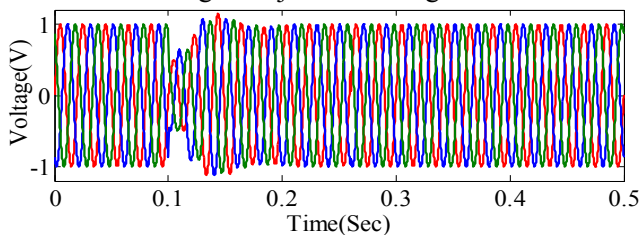

Fig.12 Load Voltage

The output of voltage sag compensation with multilevel based DVR. 50% voltage sag occurs on the

source voltage at the time period 0.1s to 0.25s. This transformer injects the voltage required to maintain the voltage level. The mismatch in voltage is mitigated by the DVR as shown in fig 10,11 and 12.

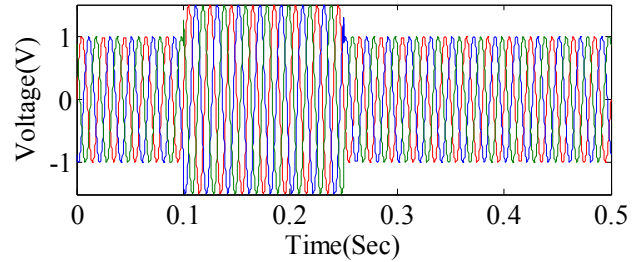

Fig.13 Source Voltage swell

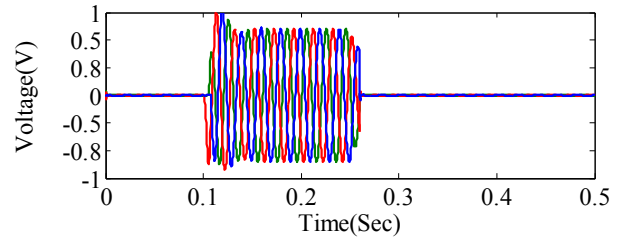

Fig.14 Injection Voltage

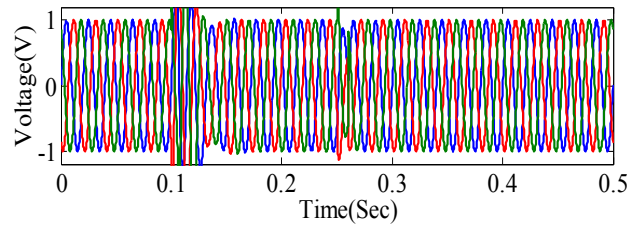

Fig.15 Load Voltage

The output of voltage swell compensation with multilevel based DVR. 150% Swell occurs on the source voltage at the time period 0.1s to 0.25s. It has been compensated by the injection transformer of capacity 36KVA level as shown in fig 13,14 and 15.

5. Conclusion

The DVR based multilevel inverter along with filter and its connected to the three phase series transformer has implemented. The voltage sag and swell is exemplary mitigated by the multilevel inverter. The Seven levels H-bridge inverter output also examined with SRF controller, Sag of 50% and swell of 150% has been compensated and the voltage level is maintained properly at the point of common coupling. Further, this work can be improved by increasing the level of the converter used in DVR. This project mainly focuses on two power quality issues namely, sag, swell. For improving power quality, other power quality problems can also be considered and rectified.

Acknowledgment

The authors wish to thank the Management and Principal of Thiagarajar College of Engineering, Madurai, Tamil Nadu, India, for their continuous encouragement in this research. This work is supported by the University Grants Commission's/ UGC- Rajiv Gandhi National Fellowship (Award Letter No:F1-17.1/2012-13/RGNF-2012-13-SC-TAM-17922 / (SA-III/Website) 6th June 2012.

References

1. Chapman D. The cost of poor power quality (European Copper Institute). Copper Development Association 2001; March.
2. Lamoree J, Mueller D, Vinett P. Voltage sag analysis case studies. IEEE Trans. Ind. Applications 1994; 30 (4): 1083–1089.
3. Bollen M.H.J. Understanding power quality problems: voltage sags and Interruptions (New York, Saranarce University of Technology, 2000.
4. Sasitharan S. Rating and design issues of DVR injection transformer. In: Applied power electronic conference (APEC). IEEE; 2008. p. 449–55.
5. Newman K, Holmes M.J, Blaabjerg D.G. A dynamic voltage restorer (DVR) with selective harmonic compensation at medium voltage level. IEEE Trans.Ind. Applications 2005; 41(6): 1744–1753.
6. Chandrasekaran , Ramachandaramurthy.V.K. An improved Dynamic Voltage Restorer for power quality improvement. International Journal of Electrical Power & Energy Systems 2016; 82: 354-362.
7. Karanki S, Geddada N, Mishra Mahesh K, Kumar B. A DSTATCOM topology with reduced dc-link voltage rating for load compensation with non-stiff source. IEEE Trans Power Electron 2012; 27(3):1201–11.
8. Saritha Natesan, Jamuna Venkatesan. Enhancing power quality on solar grid connected system using multi-level inverter and dynamic voltage restorer. Journal of Electrical Engineering 2016; 16(4): 189-202.
9. Chandrasekhar Siva Sai Krishna Potharlanka O, Nagi Reddy B. Cascaded Multilevel Inverter Topology with Reduced Number of Switches and Sources Arranged in Matrix Structure Journal of Electrical Engineering 2016; 16(4): 375-383.
10. Fayçal Chabni, Rachid Taleb, M'hamed Helaimi. High Order Harmonics Elimination in Modified Single Phase 5-level Cascaded H-bridge Inverter Using HGA. Journal of Electrical Engineering 2016; 17(3): 469-474.
11. Metin Kesler, Engin Ozdemir. Synchronous Reference frame based control method for UPQC under unbalanced and distorted load conditions. IEEE Transactions on Industrial Electronics 2011; 58(9).