

# HARMONIC ANALYSIS OF FRACTIONAL ORDER PID CONTROLLED INDUCTION MOTOR WITH PV BASED SAF

Sivakumar Arunachalam<sup>1</sup> And Dr. Srinivasan Arumugam<sup>2</sup>

<sup>1</sup>Associate professor, Department of EEE, Panimalar Engineering College, Chennai-600123, India

<sup>2</sup>Associate professor, Department of Mechatronics, Chennai Institute of Technology, Chennai-69, India.

<sup>1</sup>arunsiva75@gmail.com and <sup>2</sup>a.srinivasan2025@gmail.com

**Abstract:** This paper deals with the reduction of source current harmonics in Fractional Order PID controlled induction motor with solar PV based SAF. The solar PV based zeta converter controlled shunt active filter (SAF) can regulate the source current harmonics in desired limits due to the presence of nonlinear loads. The comparative results of source current harmonic THD levels in the PID and FOPID controlled induction motor have been presented. In this proposed system suggested a new way of SAF connection at the supply end along with FOPID control. The proposed system is modeled and simulated using MATLAB/Simulink software. The Simulation results of FOPID controller give better performance than the traditional PID controller.

**Keywords:** FOPID controller, Induction motor, PV based Zeta converter, SAF, THD

## 1. Introduction

The AC induction motors are widely used in industrial drives, domestic and commercial applications due to their merits as compared DC motor drives. Recently, rapid increases in the use of nonlinear loads such as power electronic converter fed motor drives, soft loads, battery charging circuits, arc lamps, etc. These nonlinear loads explicitly introduce the harmonics and its associated problems in the power system network. Many researchers addressed the different filter's configuration and algorithms to mitigate or reduce the harmonics in the power system with presence of nonlinear loads.

The various controllers have been suggested and documented in the literature for controlling the speed, torque and performance enhancement of

induction motor using traditional P, PI, PID controllers, FLC, ANN, Fuzzy based PID controllers and FOPID controllers, etc. The conventional PID controller is quite popular in the industrial control applications due to their simplicity, accuracy and parameter adaptation. For the complex nonlinear system, control requires modified version of conventional PI/PID controllers like Fuzzy tuned PID, ANN based PID and Ninteger PID i.e., Fractional order PID (FOPID) controllers [1-21].

The design of FOPID controllers for induction motor applications is discussed in [2, 9, 14, 20 & 21]. Comparative study of speed control of induction motor using PID and Fuzzy PID controller has been presented in [7 & 10]. The traditional PI and FOPI controlled induction motor simulation results reported in [1, 6, 10, 13 & 14]. Mathematical modeling and design of FOPID controller are reported in [3-5]. Performance analysis of stand-alone PV powered AC pump system driven by induction motor using Fuzzy PID and FOPID controller demonstrated in [8]. Mitigation of source current harmonics using PI, PID, FLC and ANN controlled induction motor is reported in [16-19]. Optimization technique using FOPID controller is reported in [17].

In the literature as mentioned earlier, reduction of source current harmonics using FOPID controlled induction motor is not discussed. In this paper a novel scheme introduced for reducing the source current harmonics and performance enhancement of FOPID controlled induction motor with PV based zeta converter regulated SAF. The FOPID controller

provides better performance and noticeable reduction in source current harmonic THD levels.

This paper is organized as follows, Section 1 briefly addresses the introduction, Proposed system is described in section 2, an FOPID controller basics and mathematical model is described in section 3, Vector control of induction motor is presented in section 4, Simulation results are discussed in section 5, Finally, the conclusion is briefly presented in section 6.

## 2. Proposed system Description

This paper suggested a new scheme reduce the source current harmonics by adding a shunt active filter (SAF) on the supply side. The existing method of VSI fed induction motor drive with SAF is shown in Fig.2.1. Most of the literature discusses the mitigation of harmonics by using the active shunt filter at the point of common coupling (PCC) [11 & 15].

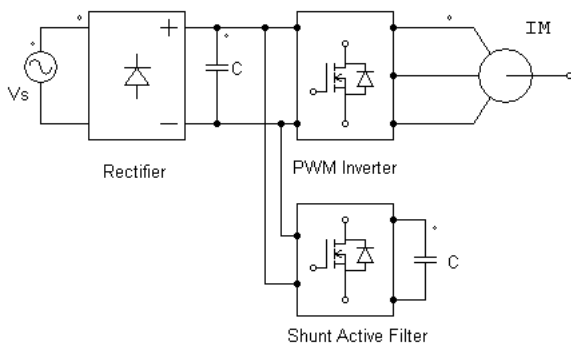

Fig. 2.1 The existing method of VSI fed induction motor with SAF

The block diagram of an FOPID controlled induction motor drive with solar PV powered Zeta converter fed SAF is shown in Fig.2.2. In this proposed system consists of a single phase diode bridge rectifier supplied by the single-phase AC source. A DC link capacitor provided to regulate constant DC input voltage to PWM controlled voltage source inverter (VSI). The regulated stator voltage has been applied to control the speed of three phase induction motor.

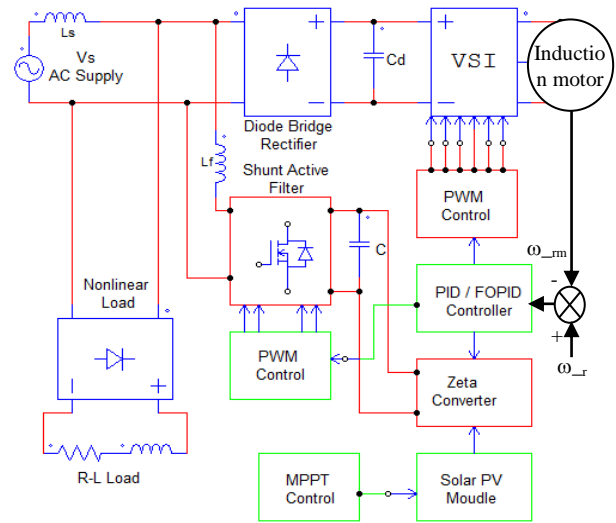

Fig. 2.2 The block diagram of FOPID controlled Induction motor with solar PV powered ZCSAF

The entire control action is carried out by traditional PID and FOPID controllers. The power converter fed induction motor is considered as a nonlinear load and introduces the harmonic disturbances in the connected power system. The active shunt filter is employed to produce opposite harmonic currents to remove the harmonics injected by the nonlinear loads. This method satisfies the harmonic limits indicated by international standards IEC 63000-2. This paper suggests the optimal controller based on modeling and simulation results of traditional PID and FOPID controlled systems. The solar PV powered Zeta converter controlled shunt filter is utilized to reduce the source current harmonics generated by VSI fed induction motor drive. Zeta converter is a single stage DC-DC buck-boost converter. It behaves like SEPIC converter and operating in two modes such as continuous current mode (CCM) and discontinuous current mode (DCM).

In this work, CCM mode operation has considered for Zeta converter. The solar PV powered Zeta converter is shown in Fig.2.3. The Zeta converter has many advantages such as inherent DC isolation between input and output, less DC output voltage ripple, simple compensation techniques, and continuous output. Also, behaves like a buck-boost converter.

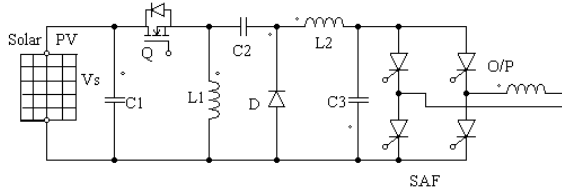

Fig. 2.3 Schematic diagram of Zeta converter Controlled Shunt Active Filter (ZCSAF)

The output voltage equation of the zeta converter is given in Eq (1)

$$V_o = \left( \frac{\delta}{1-\delta} \right) V_s \quad (1)$$

From Eq (1), zeta converter operates as a buck or boost mode based on the duty factor  $\delta$ . The duty cycle of zeta converter is varied from 0 to 1. Zeta converter is operating in buck mode ( $V_o < V_s$ ) for duty cycle of  $0 < \delta < 0.5$  and the boost mode ( $V_o > V_s$ ) for duty cycle of  $0.5 < \delta < 1.0$ .

The controlled output voltage of Zeta converter is supplied to the input of shunt active filter to regulate the opposite harmonics produced by the shunt active filter (SAF). The input of zeta converter is from MPPT controlled solar PV array module. The tremendous value of solar energy available is the solar system that can be utilized to meet out the electric power demand. Many control techniques have been proposed to extract the optimal electrical power from solar photovoltaic array modules. The straightforward and efficient method of Perturb & Observe based MPPT control algorithm is used in this system to attain the maximum power from the solar PV array panels with varying atmospheric conditions.

### 3. FOPID Controller

The fractional order calculus is derived from traditional calculus, and it consists of the fractional order of derivatives and integrals. The conventional PID controllers are well documented and applied in many control applications. Nowadays, the FOPID controllers are attracting significant attention in many control applications. The advantages of FOPID controller over the traditional FOPID controller are high accuracy, better performance, ease of controller design, less steady state error, robustness and parameter adaptation, etc. The general form of fractional order is denoted by  $aD_t^q$  where,  $a$  - is the initial limit,  $\tau$  - is the final limit and  $q$  - is the fractional order.  $PI^{\gamma}D^{\delta}$  represents the general form of

FOPID controller. Where,  $\gamma$ - fraction order (i.e., non-integer) of the integrator,  $\delta$ - fraction order of a differentiator,  $\gamma$  and  $\delta$  are integer i.e., any real numbers. The transfer function of a traditional PID controller is given in equation (2),

$$G_{ct}(s) = \frac{U(s)}{E(s)} = k_{p1} + \frac{k_{i1}}{s} + k_{d1}s \quad (2)$$

The fractional order PID controller transfer function is derived from Eq (2) and given in Eq (3)

$$G_{cf}(s) = \frac{U(s)}{E(s)} = k_{p1} + \frac{k_{i1}}{s^{\gamma}} + k_{d1}s^{\delta} \quad (3)$$

( $\gamma, \delta > 0$ )

where,  $G_c(s)$  - Transfer function of PID controller,

$k_{p1}$  - Proportional gain

$k_{i1}$  - Integral gain

$k_{d1}$  - Derivative gain

$1/S^{\gamma}$  - Fractional integral order

$S^{\delta}$  - Fractional derivative order

$E(s)$  - Error signal

$U(s)$  - Manipulated or controller output

signal

From equations (1) and (2), the selection of fractional order values of derivative and integral order parts is given in Table 1. All the traditional PID controllers are special case kind of the fractional order  $PI^{\gamma}D^{\delta}$  controller. The mode of FOPID controller is shown in Fig.3.1. The traditional PID controller is capable of operating in four modes (P, PI, PD & PID control) and whereas, the fractional order PID controller has a degree of freedom in operating modes based on fractional values. The FOPID controller operates in five modes based on the fractional order values. The systematic tuning of FOPID controller gives better performance and parameter adaptation in the dynamic system control. The block diagram of an FOPID controller is shown in Fig.3.2.

Table 1 Selection of Fractional order parameters

Fractional order parameters		Behavior of a traditional controller
$\gamma$	$\delta$	
0	0	P controller
0	1	PD controller
1	0	PI controller
1	1	PID controller

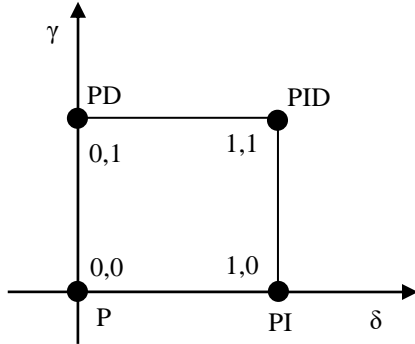

Fig. 3.1 Modes of FOPID controller

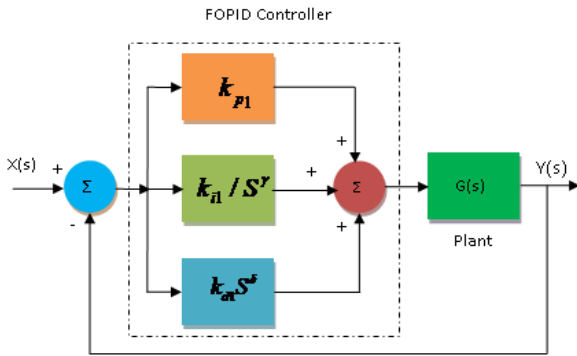

Fig.3.2 Block diagram of FOPID controller

Most of the literature addresses the speed, torque control and performance analysis of induction motors using FOPI, FOPID, and Fuzzy FOPID controllers. In this paper, a new scheme has been introduced to enhance the performance of an induction motor by reducing the source current harmonics. The main contribution of this paper is FOPID controlled induction motor with the integration of solar PV powered Zeta converter controlled active shunt filter (ZCSAF) is connected at the supply end.

#### 4. Vector Control of Induction Motor

The vector control of the induction motor is a very popular technique used in the modern high-performance AC drives. The vector control method

of the three-phase induction motor is quite popular. The three phase induction motor is made analogous to separately excited DC shunt motor. This leads to an independent control of motor torque and flux of the induction motor. The transformation between the motor voltages and currents in the stationary reference and synchronously rotating reference frames takes place for vector control operation. The controlled stator voltages are forced to regulate the speed of the motor. The simplified block diagram of PID/FOPID controlled system is shown in Fig.4.1. The block diagram of PWM gate signal generation with hysteresis controller is shown in Fig.4.2. The electromagnetic torque and angular speed of induction motor are given in Eq (4) to (7).

$$T_e = \frac{3}{2} \frac{P}{2} \frac{L_m}{L_r} (i_{q-s} \psi_{d-r}) \quad (4)$$

$$\omega_{-err} = \omega_{-r}^* - \omega_{-rm} \quad (5)$$

$$T_{Lm} = \frac{K_{-mc}}{J_{-m}s + B_{-m}} \quad (6)$$

For steady state operation,  $T_e = T_{Lm}$

$$\frac{\omega_{-err1}}{\omega_{-rm}} = \left( k_{p1} + \frac{k_{i1}}{S^\gamma} + k_{d1}S^\delta \right) \left( \frac{K_{-mc}}{J_{-m}s + B_{-m}} \right) \quad (7)$$

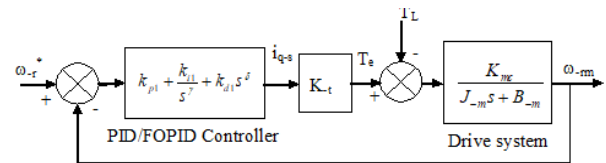

Fig.4.1 Simplified block diagram of the PID/FOPID controlled system

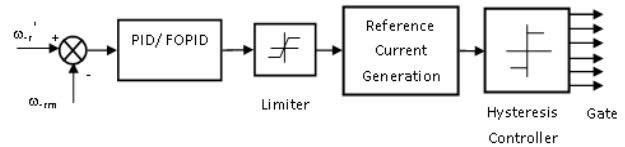

Fig.4.2 Block diagram of PWM gate signal generation with hysteresis controller

The actual speed of the induction motor is compared to the reference speed and the corresponding error signal is generated. The error signal has been used to produce proper switching pulses with the help of PI and ANN controller to control the source current harmonics through SAF.

However, the ANN controller gives the best performance in the view of the source current THDs and dynamic performance of an induction motor

### 5. Simulation Results and Discussion

The proposed system is modeled and simulated using MATLAB/Simulink software. Simulation parameters used in this system are given in Annexure-A. The open loop VSI fed induction motor is regulated with solar PV powered Zeta converter controlled SAF (ZCSAF) is shown in Fig.5.1. The Simulink model consists of various blocks such as solar PV array model, Zeta converter, shunt active filter, single-phase diode bridge rectifier and three phase VSI fed induction motor. The solar PV powered Zeta converter DC output voltage waveform is shown in Fig.5.2. The DC output voltage is boosted from 100 V to 120V at 1.7 sec. The speed response of an open loop controlled induction motor is shown in Fig.5.3. It is observed that the motor speed is varied from 900 RPM to 1250 RPM at 1.7 sec due to the step change in zeta converter output voltage. The vector control of an induction motor behaves like separately excited DC motor. The torque response of an open loop controlled induction motor is shown in Fig.5.4 and it is settled at 1.6 sec.

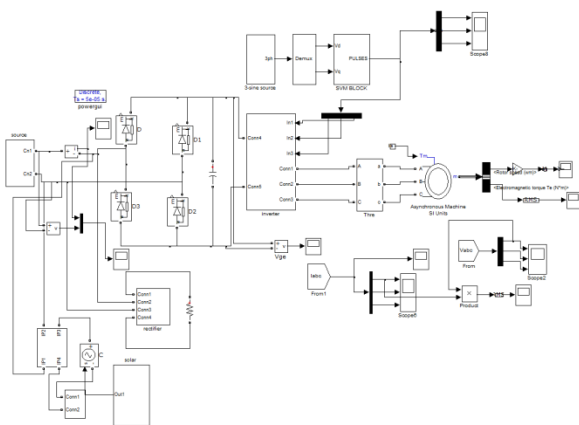

Fig.5.1 Simulink model of open loop controlled Induction motor with SAF

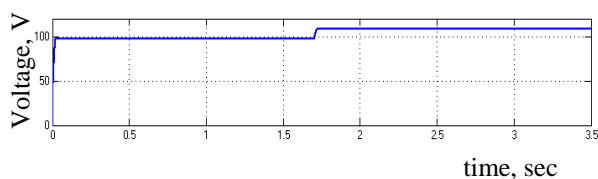

Fig.5.2 DC output voltage waveform of Zeta converter

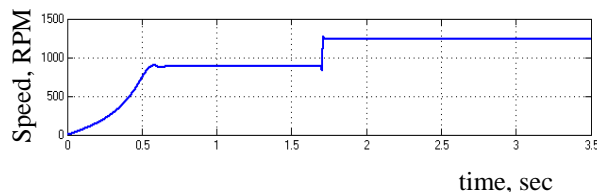

Fig.5.3 The speed response of an open loop controlled induction motor with SAF

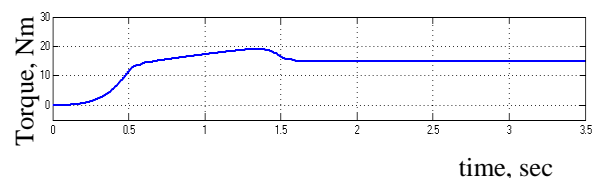

Fig.5.4 The torque response of an open loop controlled induction motor with SAF

The Simulink model of closed loop traditional PID controlled VSI fed induction motor with solar PV powered Zeta converter controlled SAF is shown in Fig.5.5. The small change in input voltage is applied to SAF and it creates voltage /current harmonic disturbances to the induction motor. These harmonic disturbances cause small variations in the motor speed for 0.5sec. The speed response of PID controlled induction motor with SAF is shown in Fig.5.6. The active shunt filter is capable of regulating the source current harmonics, and the motor speed is stabilized at the set speed. The torque response of PID controlled induction motor with SAF is shown in Fig.5.7 and settled at 4 Nm. The source current harmonic THD of PID controlled induction motor with SAF is shown in Fig.5.8, and the value of THD is about 3%.

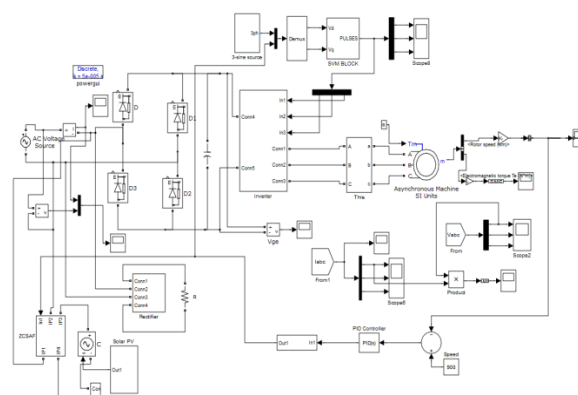

Fig.5.5 Simulink model of closed loop PID controlled Induction motor with SAF

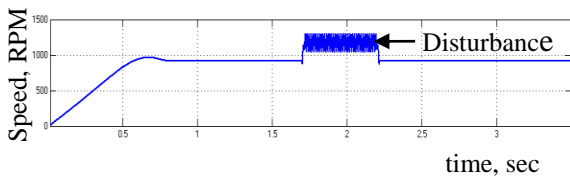

Fig.5.6 The speed response of an open loop controlled induction motor with SAF

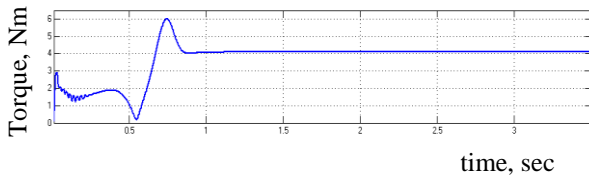

Fig.5.7 The torque response of an open loop controlled induction motor with SAF

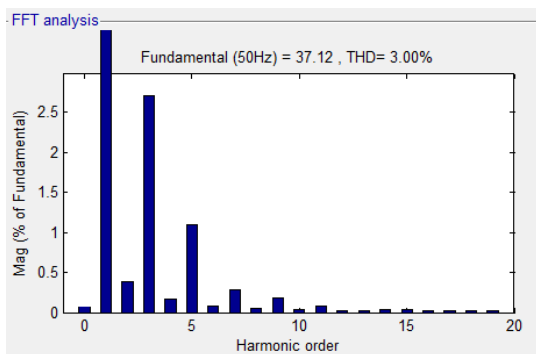

Fig.5.8 The source current harmonic THD of PID controlled induction motor with SAF

The traditional PID controller is replaced with a fractional order PID controller (FOPID) is shown in Fig.5.9, and its corresponding simulation results are presented. The speed response of an FOPID controlled induction motor with SAF is shown in Fig.5.10. It is ascertained that the speed disturbance is gradually reduced from 0.5sec to 0.16 sec, i.e. about 30% of reduction as compared to the traditional PID controller. The torque response of an FOPID controlled induction motor with SAF is shown in Fig.5.11 and it remains same. The source current harmonic THD of FOPID controlled induction motor with SAF is shown in Fig.5.12 and the value of THD is about 2.72%. It is revealed that the FOPID controlled system source current harmonic THD is reduced about 10% as compared with the traditional PID controller. The time response performance specifications of PID and FOPID controlled induction motor system is given in Table 2. It is ascertained that the FOPID controller greatly reduces the performance specifications such

as rise time, peak time, settling time and steady state error as compared to the traditional PID controller. Based on the performance analysis the FOPID controller is superior to the conventional PID controller. The time response specifications of PID/FOPID controlled system is shown in Fig.5.13 and The source current harmonic THD of PID/FOPID controlled system is shown in Fig.5.14.

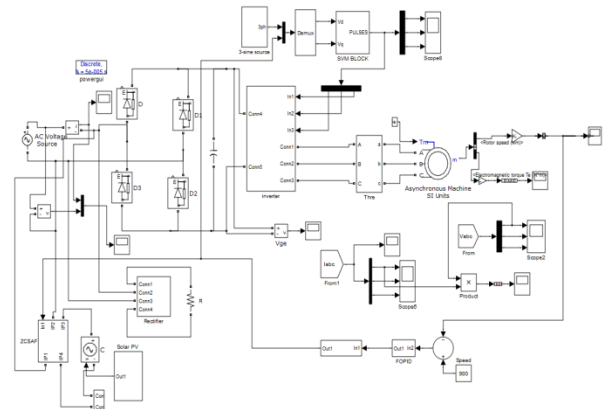

Fig.5.9 Simulink model of closed loop FOPID controlled Induction motor with SAF

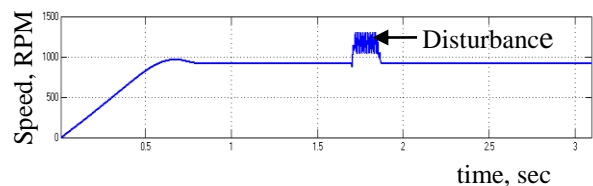

Fig.5.10 The speed response of FOPID controlled induction motor with SAF

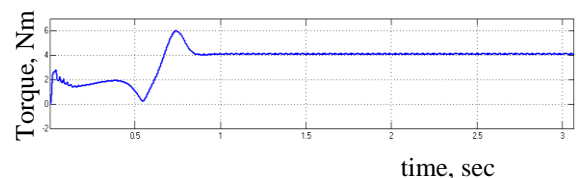

Fig.5.11 The torque response of FOPID controlled induction motor with SAF

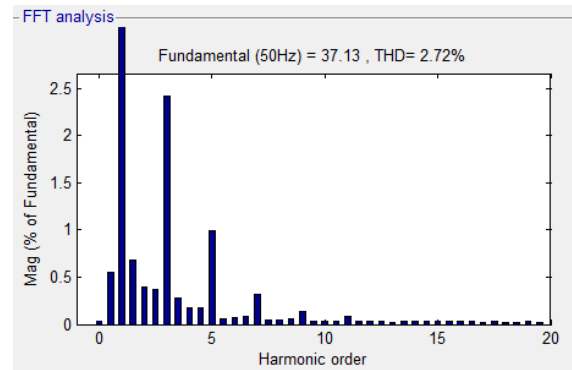

Fig.5.12 The source current harmonic THD of FOPID controlled induction motor with SAF

Table 2 Comparison of source current harmonic THD in ZCSAF

Type of controller	%THD
PID controller	3.0 %
FOPID Controller	2.72%

Table 3 Comparison of Time domain parameters

Induction motor drive	$T_r$	$T_s$	$T_p$	% $E_{ss}$
PID controller	1.18	2.4	1.19	5
FOPID Controller	1.17	1.8	1.7	2.8

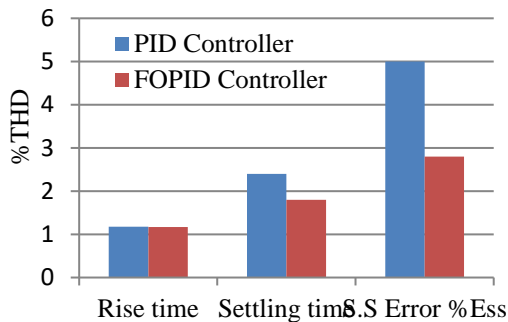

Fig.5.13 Source current THD of PID / FOPID Controlled system

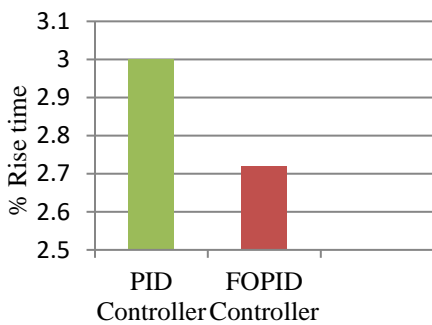

Fig.5.14 Time response specification of PID / FOPID Controlled system

## 6. Conclusion

In this work, traditional PID and FOPID controlled three phase induction motor with solar PV powered Zeta converter regulated SAF is modeled simulation results are presented. The three phase induction motor is considered as a nonlinear load. The source current harmonics are adjusted with the help of solar PV powered Zeta converter controlled active shunt filter. From the simulation results, it is revealed that the FOPID controller is superior to the

traditional PID controller. The FOPID controller is indicated that the overall performance of the three phase induction motor system is improved. It is observed that the FOPID controller gave a quick response and reduced steady-state error has compared to traditional PID controllers. Also, the % THD of source current harmonic is significantly reduced using the FOPID controller in this proposed system. The obtained THD value of the proposed system is lesser than the reported in [17].

The simulation and experimental analysis of a proposed system with FOPID controller and Fuzzy FOPID controller are discussed in the future.

## Appendix-A

The parameters used for the MATLAB simulation are 4-pole, 3 $\phi$ , 5.4HP/4kW, 415V, 50Hz, 990 RPM squirrel cage induction motor. The motor parameters are

Stator resistance $R_s$	= 1.405 $\Omega$
Stator inductance $L_{ls}$	= 5.839mH
Rotor resistance $R_r$	= 1.395 $\Omega$
Rotor inductance $L_{lr}$	= 5.839mH
Mutual inductance $L_m$	= 0.1722H
Inertia J	= 0.0131 kg-m <sup>2</sup>
Friction coefficient F	= 0.2985N-m-s
Solar PV Output voltage	= 100 V
Insolation level	= 1000 W/m <sup>2</sup>
Solar PV current $I_{pv} = I_{ref}$	= 4.95A
Zeta converter output voltage	= 110V (DC)
PID parameters	- $k_{p1} = 3$ , $k_{i1} = 5$ & $k_{d1} = 0.0009$

## References

- [1]. Adil Khurram, Habibur Rehman, Shayok Mukhopadhyay, "A High-Performance Speed Regulator Design for AC Machines", *IEEE Applied Power Electronics Conf. and Exposition (APEC)*. Long Beach, CA, USA, pp.2782-2787, doi:10.1109/APEC.2016.7468258.
- [2]. Bendjedia.M, Tehrani.K.A., Azzouz.Y, "Design of RST and Fractional Order PID Controllers for an Induction Motor Drive for Electric Vehicle Application", *7<sup>th</sup> IET Int. Conf. on Power Electronics, Machines, and Drives (PEMD 2014)*, Manchester, UK. pp.1-8, 2014, doi:10.1049/cp.2014.0445
- [3]. Concepción.A, Monje, YangQuan Chen, Blas M. Vinagre, Dingyü Xue, and Vicente Feliu,

- “Fractional-Order Systems and Controls: Fundamentals and Applications”, *Advances in Industrial Control*, Springer-Verlag, London, pp.121-130, 2010 doi:10.1007/978-1-84996-335-0.
- [4]. Erdem Ilten, and Metin Demirtas, “Off-Line Tuning of Fractional Order  $PI^\lambda$  Controller by Using Response Surface Method for Induction Motor Speed Control”, *Control Engg. and Applied Informatic*, Vol.18, no.2, 20-27, 2016.
- [5]. Igor Podlubny, “Fractional Order Systems and  $PI^\lambda D^\mu$ -Controllers”, *IEEE Trans. on Automatic Control*, Vol.44, no.1, 208-214, 1999.
- [6]. Manuel A. Duarte-Mermoud, Felipe J.Mira, Ian S.Pelissier and Juan.C and Travieso-Torres, “Evaluation of a Fractional Order PI Controller Applied to Induction Motor Speed Control”, *8<sup>th</sup> IEEE Int. Conf. on Control and Automation*, Xiamen, China, pp.573-577, 2010.
- [7]. Mohamed Jasim Mohamed and Amjad Khashan, “Comparison Between PID and FOPID Controllers Based on Particle Swarm Optimization”, *The Second Engineering Conf. of Control, Computers and Mechatronics Engg. (ECCCM2'14)*, Baghdad, Iraq, pp.1-8, 2014.
- [8]. Mohamed Mahmoud Ismail, and Ahmed Fahmy Bendary, “FOPID Controller Based AC Pump Supplied from PV Standalone Source Tuned using Fuzzy Logic Type 2”, *Indonesian J. of Electrical Eng. and Comp. Sci.* Vol.4, no.1, pp.10-19, 2016, doi:10.11591/ijeecs.v4.i1.
- [9]. Mohammad Reza Faieghi, and Abbas Nemati, “On Fractional-Order PID Design: Applications of MATLAB in Science and Engineering”, *InTech*, pp.273-292, 2011.
- [10]. Mohammadreza Vahedpour, Abolfazl Ranjbar Neoi, and Hedyeh Agheh Kholerdi, “Comparison between Performance of Conventional, Fuzzy and Fractional Order PID Controllers in Practical Speed Control of Induction Motor”, *2<sup>nd</sup> Int. Conf. on Knowledge Based Engg. and Innovation (KBEI)*, 2015, Tehran, Iran, pp.912-916.
- [11]. Muthu Selvan.N.B, Dash.S.S, and Somasundaram.P. “A High-Performance Induction Motor Drive System using Fuzzy Logic Controller”, *IEEE Int. Conf. TENCON, 2006*, Hong Kong, pp.1-4, doi: 10.1109/TENCON.2006.343938.
- [12]. Muthu Selvan.N.B, Dash.S.S, and Somasundaram.P, “Artificial Neural Network Controlled Shunt Active Power Filter”, *Annual IEEE India Conf.*, September 2006, New Delhi, pp. 1-5, 2006, doi:10.1109/INDCON.2006.302852.
- [13]. Nagarajan.M., Asokan.A, Manikandan.M, and Sivakumar.D, “Concentration Control of Isothermal CSTR using Particle Swarm Optimization based FOPID Controller”, *Middle East J. of Scientific Research*, Vol.24, no.3, 967-971, doi:10.5829/idosi.Mejsr.2016.24.03.23237.
- [14]. Narmada.R and Arounassalame.M, “Design and performance evaluation of Fractional Order Controller for Brushless DC Motor”, *Int. J. on Electrical Eng. and Informatics*, Vol.6, no.3, 606-617, 2014.
- [15]. Serein Al-Ratrou, Ashraf Saleem, and Hisham Soliman, “Optimization Methods in Fractional Order Control of Electric Drives: A Comparative Study”, *10th Int. Sympo. on Mechatronics and its Applications (ISMA)*, December 2015, Sharjah, United Arab Emirates, pp.1-6, 2015, doi:10.1109/ISMA.2015.7373460.
- [16]. Sivakumar.A, Muthamizhan.T, Gunasekhar.N.O and Ramesh.R, “A Novel Sensorless Speed Control Strategy of Induction Motor based on Vector Control”, *Int. Rev. Electr. Eng.*, Vol.8, no.4, 1211-1217, 2013.
- [17]. Sivakumar.A and Muthu Selvan.N.B, “Reduction of Source Current Harmonics in ANN Controlled Induction Motor”, *Alexandria Engg. J.*, doi:10.1016/j.aej.2017.03.048, available online from 19 April 2017.
- [18]. Sivakumar.A and Muthu Selvan.N.B, “Harmonic Analysis in Induction Motor Drive with Boost Converter”, *Int. J. Printing, Packaging Allied Sci.*, Vol.4, no.2 1159-1165, 2016.
- [19]. Sivakumar.A and Muthu Selvan.N.B, “Reduction of Source Current Harmonics in R and RL Load with Active Filter at Source End”, *Asian J. Res. Soc. Sci. Humanities*, Vol.6, no.10, 298-310,2016, doi:10.5958 /2249-7315.2016.01015.
- [20]. WeiJia Zheng, Ying Luo, XiaoHong Wang, YouGuo Pi, and YangQuan Chen, “Fractional Order  $PI^\lambda D^\mu$  Controller Design for Satisfying Time and Frequency Domain Specifications



Simultaneously”, *ISA Trans.*, 68, pp.212-222, 2017, doi:10.1016/j.isatra.2017.02.016.

- [21]. Yeong-Hwa Chang, Chun-I Wu, Hung-Wei Lin, Chang-Hung Hsu, and Guan-Wei Liao, “Design of Fractional-Order PID Controller for Vector Controlled Induction Motors”, *Proc. of the 9th WSEAS Int. Conf. on Robotics, Control and Manufacturing Tech., (ROCOM'09)*, May 2009, Hangzhou, China, pp.142-147.