

# PERFORMANCE ANALYSIS OF PV FED MOD SEPIC CONVERTER FOR MANET

**C. Rajmohan,**

Assistant Professor, Department of Information Technology, Sri Ramakrishna Engineering College(Autonomous),Tamil Nadu, India. chellabommu@gmail.com

**Dr. K.R.Shankar Kumar**

Professor, Department of Electronics and Communication Engineering, Kalaignar karunanidhi Institute of Technology, TamilNadu, India.

## **Abstract:**

*As innovation quickly increases, different sensing and mobility capacities have turned out to be promptly accessible to gadgets and, thus, mobile ad hoc networks (MANETs) are being sent to play out various important tasks. Uninterrupted power source is required for devices in the MANET for continuous communication. In the aspect of power devices, MANET continuously consumes power from the grid. To reduce power consumption from the grid and for continuous communication, this paper proposes renewable PV source for the network. Mod sepic is proposed in PV system for its operation characteristics as low-switch-voltage operation and high static gain at low line voltage. For enhanced performance of the PV system Modified SEPIC converter with Fuzzy logic controller MPPT is proposed. This paper proposes PV power system for MANET which reduces power consumption from grid and improves reliability of supply. Improved performance Mod SEPIC converter and Fuzzy MPPT are proposed to effectively utilize PV system with minimized voltage stress on devices. The performance of proposed entire system is analyzed using Simulation.*

**Keywords:** MANET, PV, Mod SEPIC converter, Fuzzy MPPT.

## **1. INTRODUCTION**

A Mobile Ad hoc Networks (MANET) represents a system of wireless mobile nodes that can freely and dynamically self-organize into arbitrary and form temporary network topologies [1]. Routing is the most fundamental research issue in MANET and must manage restrictions, for example, low bandwidth, high power consumption, high error rates and unpredictable movements of nodes. Current routing protocols for MANET can be categorized as (i) Reactive (ii) Proactive and (iii) Hybrid.

Reactive protocols set up path based on the present needs for which they are known as the on-demand routing protocol. Proactive protocols in other hand attain the path by the help of routing table data. Routing tables are periodically updated. Hybrid protocols are the combination of some feature from both protocols. Reactive protocols are viewed as the most appropriate for a system with higher mobility as a contrast with proactive protocols. Proactive protocols are

suitable for the static network where node information does not change frequently.

The vulnerability is a weakness in the security system. A specific system might be vulnerable to unapproved information control because the system does not check a client's identity before permitting information to get to. MANET is more vulnerable than a wired network. Some of the vulnerabilities are Lack of centralized management, resource availability, Scalability, Dynamic topology, cooperativeness, Bandwidth constraint, Limited power supply, Adversary inside the Network and No predefined Boundary.

One important aspect of ad-hoc networks is power efficiency since only a simple battery provides nodes independence. In MANETs, every node needs to play out the functions of a router. So if few nodes stop working early due to absence power so that the network becomes disconnected, then it may not be possible for other nodes in the network to communicate with each other. In this analysis, all or some of the devices used in MANET are powered using Photovoltaic power. This proposed system not only reduces all day power consumption from it also ensures reliability of uninterrupted power networking.

India is a tropical country where the amount of sunlight is mostly available to meet up the demand of producing electricity. Photovoltaic systems have recently attracted more attention as a prominent renewable energy source, which is significantly contributing to the sustainable energy supply. It becomes attractive to emerging technology due to several distinctive advantages such as simplicity of allocation, high dependability, declining cost of solar modules, low maintenance and absence of noise and wear. In solar PV system, the sunlight is directly converted into the electrical energy. The energy that can be produced by a solar cell depends on the intrinsic properties of the cells and the amount of solar radiation which falls on the panel [2]. Since the I-V characteristics curve of PV cells varies nonlinearly with the

irradiation and temperature, it is essential to operate PV system to specific point to extract maximum solar energy.

This technology is usually named as MPPT [3,4]. Many MPPT methods have been developed and implemented by many researchers including perturb and observe (P&O), incremental conductance (InC) and hill climbing algorithm. In a P&O algorithm, the power loss is high contrast with all other algorithms. In an InC algorithm selection of step size is complicated which decides the efficiency and response time of tracking [5,6]. Hill climbing algorithm is not efficient in tracking the maximum power with sudden variation in environmental condition. As a result, FLC-based MPPT algorithm attracts many research interests [7]. The variable voltage from the PV panel necessitates a DC-DC converter in between PV panel and load.

To charge the battery variable voltage from PV has to regulate to the required level of voltage. So the step up/down converter is required in this system. Among the various converters such as buck-boost, positive buck-boost, Cuk and SEPIC converter for PV application SEPIC [8] produce efficient performance with reasonable cost

Table 1: Comparing various buck-boost converters

	CONVERTERS			
	Buck-Boost	CUK	Positive buck-boost	SEPIC
Output Voltage polarity	Invert	Invert	Non-invert	Non-invert
Input current	Pulsating	Non-pulsating	Depends on operation mode	Non-pulsating
Switch drive	Floated	Floated	One floated one grounded	Grounded
Efficiency	Low	Medium	High with only one stage active	Medium
Cost	Medium because of float drive	Medium because of additional block capacitor	Maximum because of an additional diode and switch, a more complex	Moderate because of additional block capacitor

			drive circuit	
--	--	--	---------------	--

In this analysis, Modified SEPIC is an advanced SEPIC converter is proposed for performance enhancement.

## 2. SOLAR PHOTOVOLTAIC SYSTEM

### A. Photovoltaic Module

Photovoltaic (PV) module is a sort of device used to change sunlight into electrical energy. It is formed by a blend of numerous solar cell associated in series and in parallel according to the needed amount of current and voltage. As sunlight strikes a solar cell, the incident energy is changed over specifically into electrical energy with no mechanical exertion [9].

### B. Equivalent Circuit of PV Module

Considering a model of a single diode, then a solar cell is designed as shown in Fig. 1. This model provides an improved compromise between accuracy and simplicity with the basic structure contains a current source and a parallel diode,

Where by  $I_{ph}$  represents the cell photocurrent while  $R_{sh}$  and  $R_s$  are, respectively, the intrinsic shunt and series resistances of the cell [10]

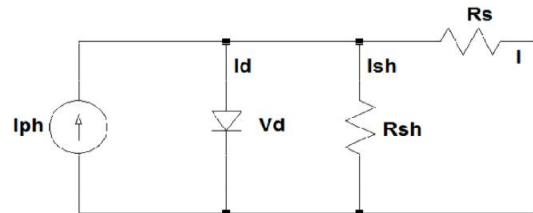

Fig.1.Schematic diagram of single diode solar cell

### C. Equations of a PV Cell

PV cells are gathered in bigger units called PV modules, which are further interconnected in a series and in parallel design to shape PV arrays. The accompanying is the essential conditions from the hypothesis of semiconductors and photovoltaic that mathematically portray the I-V normal for the photovoltaic cell and module [11].

### D. Photo Current

The PV cell photocurrent  $I_{ph}$  depends linearly on the solar irradiation and it is also influenced by the temperature according to (1).

$$I_{ph} = [I_{SC} + K_1(T_C - T_{ref})] * H \quad (1)$$

Where the nominal generated current at 25°C is  $I_{ph}$  and  $1\text{kW/m}^2$ ; the short-circuit current of the cell at 25°C is  $I_{sc}$  and  $1\text{kW/m}^2$ , the cell short-circuit current per temperature coefficient of the cell is  $K_1$  (0.0017A/K), reference temperature of the cell is  $T_{ref}$ , and the solar insolation in  $\text{kW/m}^2$  is  $H$ .

### E. Reverse Saturation Current of PV Module

PV module reverse saturation current,  $I_{rs}$ , is given by

$$I_{rs} = \frac{I_{sc}}{\left[\exp\left(\frac{qV_{oc}}{N_s K A T}\right) - 1\right]} \quad (2)$$

Where  $k$  is the Boltzmann constant ( $1.3805 \times 10^{-23} \text{ J/K}$ ),  $q$  is the electron charge ( $1.6 \times 10^{-19} \text{ C}$ ),  $N_s$  is the number of cells connected in series,  $V_{oc}$  is the PV module open-circuit voltage,  $A$  is the ideal factor (1.6).

### F. Saturation Current of PV Module

The PV module saturation current  $I_o$  changes with the cell temperature and is given by (3). Where:  $E_{go}$  is the bandgap energy of the semiconductor ( $E_{go} \approx 1.1\text{eV}$  for the polycrystalline Si at 25°C).

$$I_o = I_{rs} * \left(\frac{Y}{T_r}\right)^2 * \exp\left[\left(\frac{(q * E_{go})}{(A * K)}\right) * \left(\left(\frac{1}{T_r}\right) - \left(\frac{1}{T}\right)\right)\right] \quad (3)$$

### G. Module Output Current $I_{PV}$

The basic equation that describes the current output of the PV module  $I_{PV}$  of single diode model presented in Fig. 1 is given by (4).

$$I_{PV} = N_p * I_{ph} - N_p * I_o \left[ \exp\left(\frac{q * (V_{Ph} + I_{PV} * R_s R_s)}{N_s * A * K * T}\right) - 1 \right] - \frac{V_{PV} + (I_{PV} * R_s)}{R_{sh}} \quad (4)$$

Where  $N_p$  is the number of parallel connection of cell,  $N_s$  is the number of series connections of cells,  $V_{PV} = V_{oc}$  is open circuit voltage,  $R_{sh}$  is the equivalent parallel resistance,  $R_s$  is the equivalent series resistance of the module. The effect of parallel resistance, when it is sufficiently small, is to reduce the open-circuit voltage and the fill factor [12]. The value of  $R_{sh}$  does not affect the short-circuit current.

In general, the value of parallel resistance  $R_{sh}$  is kept high, and it is neglected in expression to simplify the model as given

by (5). The series resistance  $R_s$  (around 0.1 $\omega$ ) is the aggregate of a few structural resistances of the PV module, and its impact is stronger particularly close to the maximum power point area. Equation (4) for the output current of PV module can be expressed as shown by (5).

$$I_{PV} = N_p * I_{ph} - N_p * I_o \left[ \exp\left(\frac{q * (V_{Ph} + I_{PV} * R_s R_s)}{N_s * A * K * T}\right) - 1 \right] \quad (5)$$

In this paper, the specifications of the photovoltaic panel have been used are listed in Table I.

Table 2: PV panel electrical specifications

S.NO	ELECTRICAL PARAMETER	VALUE
1	Maximum Power (Pmax)	85
2	Voltage at Pmax (Vmp)	12
3	Current at Pmax (Imp)	7.04
4	Open-circuit voltage (Voc)	16
5	Short-circuit current (Isc)	9.4

### 3. Mod SEPIC converter

The step-down and step-up static gain of the SEPIC converter is a fascinating working characteristic for a wide range of input voltage application.

The voltage multiplier method was analyzed in [13] so as to increase the static gain of single and multiphase voltage lift dc-dc converters. An adjustment of the voltage multiplier strategy with the SEPIC converter is displayed in Fig. 2. The alteration of the SEPIC converter is refined with the incorporation of the capacitor  $C_M$  and the diode  $D_M$ . numerous operational attributes of the traditional SEPIC converter are changed with the proposed modification [14]. The  $C_M$  capacitor is charged with the output voltage of the traditional boost converter. Accordingly, the voltage connected to the inductor  $L_2$  amid the conduction of the power switch (S) is greater than that in the conventional SEPIC, in this manner expanding the static gain. The polarity of the capacitor  $C_S$  voltage storage is inverted in the Mod SEPIC converter, and the expressions of the capacitors voltages and others

working characteristics are displayed in the hypothetical investigation.

The following two operation stages present the continuous-conduction-mode (CCM) operation of the proposed Modified SEPIC converter

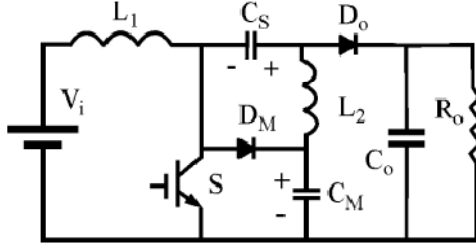

Fig.2.Modified SEPIC converter

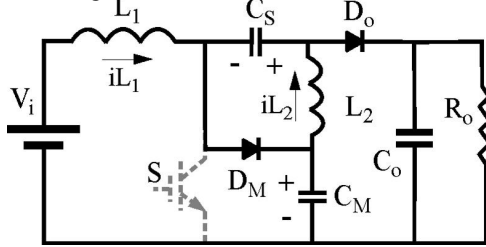

Fig.3.First operation stage

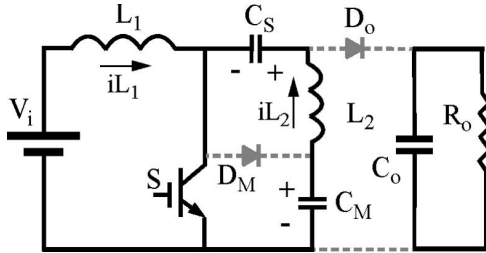

Fig.4.Second operation stage

- 1) The first stage ( $[t_0, t_1]$  Fig. 3)—At the instant  $t_0$ , the switch  $S$  is switched-OFF and the input inductor  $L_1$  transfers the stored energy to the output via the  $C_S$  capacitor and  $D_o$  output diode, and also to the  $C_M$  capacitor through the  $D_M$  diode. Therefore, the voltage of the switch is equal to the  $C_M$  capacitor voltage. The inductor  $L_2$  transfers stored energy in it to the output through the diode  $D_o$ .
- 2) The second stage ( $[t_1, t_2]$  Fig. 4)—At the instant  $t_1$ , the switch  $S$  is switched -ON and the diodes  $D_o$ , and  $D_M$  are blocked, and the energy is stored in the inductors  $L_1$  and  $L_2$ . The input voltage is given to the input inductor  $L_1$  and the voltage  $V_{C_S} - V_{C_M}$  is applied to the inductor  $L_2$ . The voltage  $V_{C_M}$  is higher than the voltage  $V_{C_S}$ .

The voltage in the power switch and all diodes is equal to the voltage of capacitor  $C_M$ . The output voltage is equal to the summation of the voltages of the capacitors'  $C_S$  and  $C_M$ . The average  $L_1$  inductor current, is equal to the input current and the average  $L_2$  inductor current is equal to the output current. From this theory, it is noted that voltage across the switching device is reduced results in a reduction in voltage stress.

Design of elements in a Mod SEPIC converter are discussed below

The static gain of the proposed converter is obtained and presented in (6)

$$V_o/V_i = (1+D)/(1-D) \quad (6)$$

Duty ratio of switching device is stated as follows

$$D = (V_o - V_i)/(V_o + V_i) \quad (7)$$

The duty cycle of Mod SEPIC is compared with boost and SEPIC converter and shown in Table 3.

Table 3: Comparison of Duty cycle

SEPIC	Boost	Modified SEPIC
$D = \frac{V_o}{(V_o + V_i)}$	$D = 1 - \frac{V_i}{V_o}$	$D = \frac{(V_o - V_i)}{(V_o + V_i)}$

The input current ripple ( $\Delta i_{L1}$ ) in the period of conduction of the power switch is given by the following equation:

$$\Delta i_{L1} = \frac{V_i D}{L_1 f} \quad (8)$$

Where  $f$  is the switching frequency

The input inductance calculated is equal to

$$L_1 = \frac{V_i D}{\Delta i_{L1} f} \quad (9)$$

The  $L_2$  volume is smaller than the  $L_1$  inductance. The  $L_2$  inductance utilized in the practical implementation is half of the  $L_1$  inductance. The proposed converter uses two inductors, but the  $L_1$  inductor can be 27% lower than the input inductor of the classical boost converter.

The high-frequency capacitor voltage ripple ( $\Delta V_c$ ) can be expressed by (15), as a function of the capacitor charge variation

$$\Delta V_c = \frac{\Delta Q}{C} \quad (10)$$

The  $C_M$  and  $C_S$  capacitances can be defined as follows

$$C_M = C_S = \frac{i_{L2}D}{\Delta V_C f} \quad (11)$$

The output capacitance is defined by a function of the output power ( $P_o$ ), the grid frequency ( $f_G$ ), and the low-frequency output voltage ripple ( $\Delta V_o$ ).

$$C_O = \frac{P_O}{2\pi f_G * 2V_O \Delta V_O} \quad (12)$$

From the equations (6) to (11) values of inductors and capacitors required for designing Mod SEPIC converter are calculated. In a PV powered system voltage gain and Duty ratio are decided by MPPT controller since input voltage is variable.

#### 4. Maximum Power Point Tracking

MPPT remains for Maximum Power Point Tracking, This technique is to automatically find the voltage and at which a PV array ought to work to acquire the maximum power output under a given temperature and irradiance [15]. Based on various applications of the PV systems, different MPPT schemes are employed. The schemes depend on several factors such as the Implementation complexity, Sensor Technology, Local climatic conditions, and Cost. In this paper fuzzy logic controller based MPPT is proposed.

##### a) Fuzzy logic controller based MPPT.

The fuzzy logic begins with and expands on an arrangement of client provided human dialect rules [16]. Block diagram of the fuzzy logic controller is shown in figure 4. Fuzzy logic can deal with problems with uncertain and fragmented information, and it can show nonlinear elements of discretionary many-sided quality.

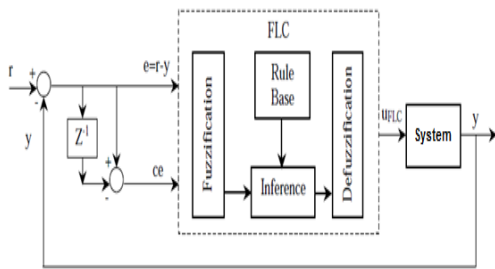

Fig.5.Second operation stage

In this method of MPPT change in voltage and change in power is taken as input like incremental conductance method. The fuzzy logic controller of MPPT produces duty ratio as output. Pulses based on this duty ratio controls the switch in SEPIC. Inputs of the Fuzzy logic controller follow equations (13) and (14).

$$\Delta p = p_i - p_{i-1} \quad (13)$$

$$\Delta v = v_i - v_{i-1} \quad (14)$$

Block diagram of the fuzzy logic MPPT is shown in figure 7. Mamdani fuzzy is proposed in this paper. Inputs of fuzzy are represented as  $\Delta p$  and  $\Delta v$ . A degree of truth for inputs are 7 and output is 9. Membership functions of inputs are {NB, NM, NS, Z, PS, PM, PB} named as Negative Big, Negative Medium, Negative Small, Zero, Positive Small, Positive Medium and Positive Big. Membership functions of output are {NVB, NB, NM, NS, Z, PS, PM, PB, PVB} it is similar to the inputs except for Negative Very Big and Positive Very Big. Figure 8 and 9 shows the membership functions of inputs and output. Surface view of FLC is shown in figure 10. Centroid method of defuzzification is proposed with 49 rules. Table 2 shows the rules of the fuzzy logic controller.

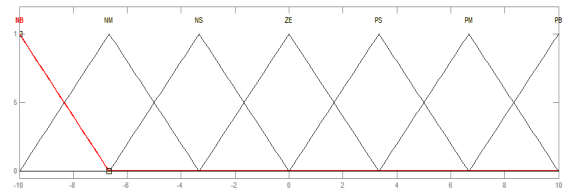

Fig.6. Membership functions of inputs E and EC

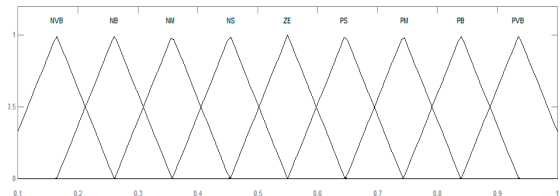

Fig.7. Membership functions of output

Table4. Control rules

$\Delta P \backslash \Delta V$	NB	NM	NS	Z	PS	PM	PB
NB	NVB	NB	NM	NS	Z	PS	PM
NM	NVB	NB	NM	NS	PS	PM	PB
NS	NVB	NB	NM	NS	PS	PM	PB
Z	NB	NM	NS	Z	PS	PM	PB
PS	NB	NM	NS	PS	PM	PB	PVB
PM	NB	NM	NS	PS	PM	PB	PVB
PB	NM	NS	Z	PS	PM	PB	PVB

Fine tuned Fuzzy controller produces better duty ratio compared to conventional controllers. It results better voltage control in Mod SEPIC and produces controlled power.

### 5. MANET

In MANET packet delivery ratio is depends upon the number of the node [17]. When the number of nodes increases power consumption from grid increases. For example, consider various clusters with various numbers of nodes for power calculation. Every cluster designed with devices of an equal number of Laptops and Mobiles. Table 5 shows current consumptions of various clusters with the 12V input.

Table 5: current consumptions of various clusters with 12V input

No of Nodes	Current consumed by Laptops (Amp)	Current consumed by Mobile phones (Amp)	Total current consumption for 12V input (Amp)
20	25	15	40
50	62.5	37.5	100
100	125	75	200

From the table 5, it is noted that when all devices in a cluster are turned ON for long time total energy consumed from the grid is high. Meantime when any one node of the cluster is disconnected from cluster due to lack of power from grid all other nodes in a cluster will be ideal for the specific time which decreases the performance of communication.

In order to enhance the performance of MANET, in this paper, some of the devices are powered using PV power system. PV power system designed for this analysis is capable of delivering power for 2 Lithium Ion batteries for 2 Laptops and one mobile or any other device. This power system can be extended in future for any requirement.

### 6. SIMULATION ANALYSIS AND DISCUSSION

To analyze the performance of PV power system with Mod SEPIC converter and fuzzy logic MPPT entire system is simulated using Matlab/Simulink. A simulation model of fuzzy logic controller based MPPT is shown in figure 9.

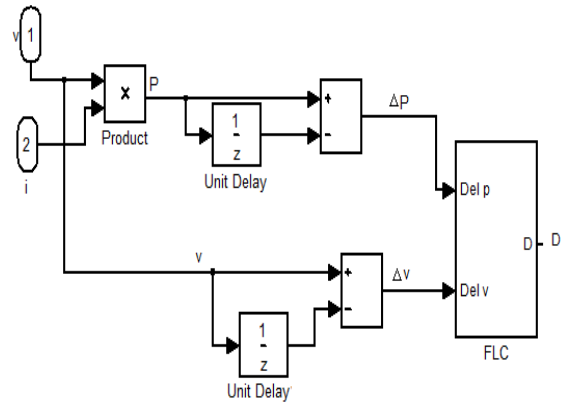

Fig.8. Simulation diagram of Fuzzy MPPT

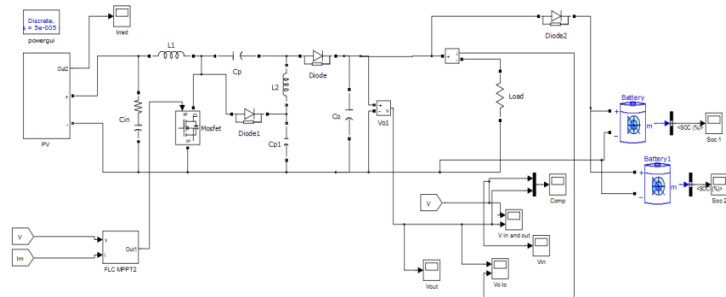

Fig. 9. Simulation model of the proposed system

For performance analysis irradiance applied to PV panel is varied from 400 to 1000 irradiance. Figure 10 shows the variation irradiance input to the solar panel. Production of voltage by the PV panel for the given irradiance is shown in figure 10, which is considered as an input to the Mod Sepic converter.

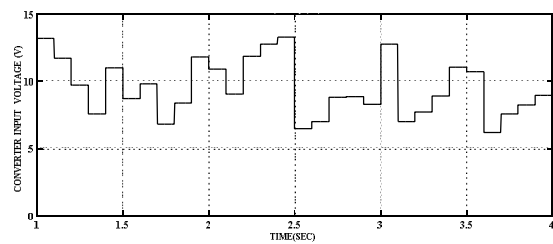

Fig.10. Converter input voltage

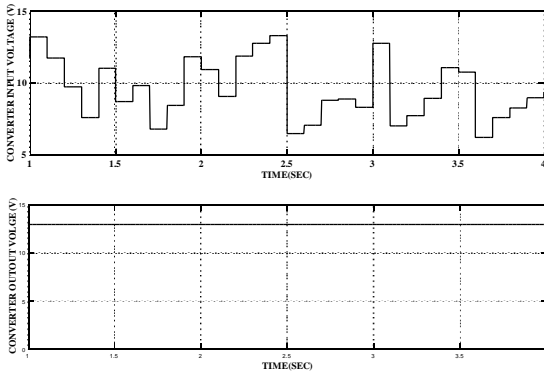

Fig.11. Performance of converter

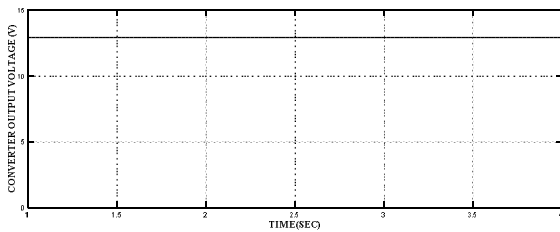

Fig.12. Converter output voltage

From the figure 11 performance of Fuzzy logic controller MPPT ability for tracking changes in input voltage and quick response of producing duty ratio is noted. From the figure 12 the performance of Mod SEPIC converter in the aspect of voltage steady state error and voltage ripple. The converter output voltage settles in the designed 13V constantly irrespective of variation in an input it states the negligible steady state error. Voltage ripple in the converter output voltage is very low and negligible, and these factors show the superior performance of Mod SEPIC converter.

From the figures performance of Mod SEPIC converter is given table6

Table6: performance of Mod SEPIC converter

Settling time (sec)	Steady state error (%)	Voltage ripple (%)
1	0.01	0.003

Load current delivered by the power system is shown in figure 13.

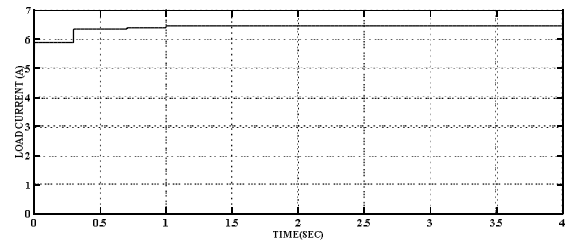

Fig.13 Load current

From the figure 13, it is noted that current delivered by the network is nearly 6.5 amperes which are capable supplying 2 Laptop batteries and one mobile battery. Charging status of two batteries is shown in Figures 14 and 15. For an analysis initial state of charge of batteries are considered as 70% and 60%.

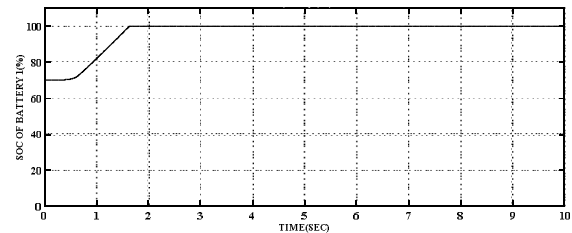

Fig.14. SOC of battery1

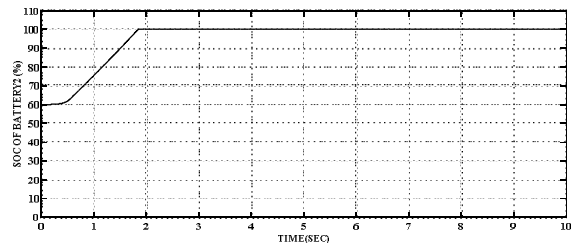

Fig.15. SOC of battery2

From the figure 15 and 14, it is noted that batteries get charging with the help of constant input DC source.

From this analysis, it is noted that Laptops are mobiles having backup power by the proposed network continues data communication in MANET even in the absence of grid power and will not disjoint from the network in the aspect of power.

## 7. CONCLUSION:

In this paper reliability of MANET is increased by PV powered devices in MANET, which will not disjoint from the network even in the absence of grid power. For the PV

power system Fuzzy logic controller MPPT controlled Mod SEPIC converter is proposed. The proposed PV power system is designed for two laptop batteries and one mobile/ any device. Mod SEPIC converter produces voltage ripple of 0.003% which is very low and maintains battery connected with it in good condition for a long time. Mod SEPIC converter has the advantage of high gain and reduced voltage stress across the devices. It results minimized size of converter, reduction in cost and beneficiaries that system is suitable for extending to any number of nodes. From the analysis, it is noted that ripple free voltage from the FLC MPPT controlled Mod SEPIC converter improves charging performance of the battery and its lifetime.

## REFERENCES

1. Corson, M. S., Macker, J. P., & Cirincione, G. H. (1999). "Internet-based mobile ad hoc networking": IEEE internet computing, 3(4), 63-70.
2. Furkan Dinçer, Mehmet Emin Meral "Smart Grid and Renewable Energy": SGRE Critical Factors that Affecting Efficiency of Solar Cells 2010 1, 47-50 doi:10.4236/sgre.2010.11007 Published Online May 2010 (<http://www.SciRP.org/journal/sgre>) Copyright © 2010 SciRes.
3. Zanotti, J. W., W. M. Dos Santos, and D. C. Martins. "The Maximum Power Point Tracking for PV systems: Introduction to the Input Characteristic Impedance method." *Power Electronics for Distributed Generation Systems (PEDG)*: 2014 IEEE 5th International Symposium on. IEEE, 2014.
4. Wu, Tsai-Fu, Chien-Hsuan Chang, and Yong-Jing Wu. "Single-stage converters for PV lighting systems with MPPT and energy backup": IEEE transactions on aerospace and electronic systems 35.4 (1999): 1306-1317.
5. Kaouane, Mohamed, Akkila Boukhelifa, and Ahmed Cheriti. "Implementation of incremental-conductance MPPT algorithm in a photovoltaic conversion system based on DC-DC ZETA converter": Modeling, Identification and Control (ICMIC), 2016 8th International Conference on IEEE, 2016.
6. Elgendy, Mohammed A., Bashar Zahawi, and David J. Atkinson. "Assessment of the incremental conductance maximum power point tracking algorithm": IEEE Transactions on sustainable energy 4.1 (2013): 108-117.
7. Chekired, F et.al., "Implementation of a MPPT fuzzy controller for photovoltaic systems on FPGA circuit". *Energy Procedia*, 2011, 6, pp.541-549.
8. El Khateb, A et.al., "Fuzzy-logic-controller-based SEPIC converter for maximum power point tracking". *IEEE Transactions on Industry Applications*, 2014, 50(4), pp.2349-2358.
9. Rekioua, Djamila, and Ernest Matagne. "Optimization of photovoltaic power systems: modelization, simulation and control". Springer Science & Business Media, 2012.
10. Rahman, Shah Arifur, Rajiv K. Varma, and Tim Vanderheide. "Generalized model of a photovoltaic panel": IET Renewable Power Generation 8.3 (2014): 217-229.
11. Al-Amoudi, A., and L. Zhang. "Application of radial basis function networks for solar-array modeling and maximum power-point prediction": IEE Proceedings-Generation, Transmission and Distribution 147.5 (2000): 310-316.
12. Bialasiewicz, Jan T. "Renewable energy systems with photovoltaic power generators: Operation and modeling": IEEE Transactions on industrial Electronics 55.7 (2008): 2752-2758.
13. F. L. Tofoli, D. S. Oliveira Jr., R. P. Torrico-Bascope and Y. J. A. Alcazar, "Novel Non isolated High-Voltage Gain DC-DC Converters Based on 3SSC and VMC": IEEE Transactions on Power Electronics, vol. 27, no. 9, pp. 3897- 3907, September 2012.
14. Gules, R., dos Santos, W. M., dos Reis, F. A., Romaneli, E. F. R., & Badin, A. "A modified SEPIC converter with high static gain for renewable applications": IEEE transactions on power electronics, 29(11), 5860-5871- IEEE.2014.
15. Soualmia, A., & Chenni, R.. "A survey of maximum peak power tracking techniques used in photovoltaic power systems": In Future Technologies Conference (FTC) (pp. 430-443). IEEE. December-2016.
16. Zadeh, Lotfi A. "Fuzzy sets": Information and control 8.3 (1965): 338-353.
17. Subbarao, Madhavi W. "Dynamic power-conscious routing for manets: An initial approach": Vehicular Technology Conference, 1999. VTC 1999-Fall. IEEE VTS 50th. Vol. 2.