

# GREY WOLF OPTIMIZATION TO HYBRID RENEWABLE ENERGY SYSTEM LOCATED IN WESTERN GHATS REGION - A CASE STUDY

G.R.VENKATAKRISHNAN<sup>1</sup>, R.RENGARAJ<sup>2</sup>

<sup>1,2</sup>Department of Electrical and Electronics Engineering, SSN College of Engineering, Chennai, TamilNadu, India

**Abstract:** *Economical, efficient and reliable hybrid renewable energy system (HRES) provides a clean and distributed energy when compared to individual renewable energy system. In the present scenario, importance of HRES is getting increased as it adapts to the climatic changes. In this paper, the considered HRES comprises of solar PV, wind and micro-hydro along with diesel generator and battery banks to serve the demand. Minimization of total cost and total dumped power are the objective functions considered for this problem. In addition, the geographical constraints is also considered in this paper to minimize the total cost of the system. Grey Wolf Algorithm (GWO) is arguably one of the simple, efficient and most powerful stochastic real-parameter optimization algorithm which operates through simple computational steps. The optimal combination of HRES problem for different objective function are determined using GWO. As a case study, a realistic data which has been used in this paper to find the acceptable combinations belong to a typical farming village of Western Ghats in Kerala, India. The simulation results of the considered problem shows that the GWO algorithm is able to provide better solution quality in terms of cost, convergence and robustness for the considered HRES problem.*

**Keywords:** *Hybrid Renewable Energy System; HRES; Grey Wolf Algorithm; GWO; solar PV; wind; micro-hydro; kerala*

## 1. Introduction

Dependency on conventional energy sources and its associated environmental problems can be solved by exploiting the enormous potential of renewable energy sources (RES). In addition, RES can provide basic energy facilities to remote areas where grid facility is impossible to setup. Moreover, enormous potential of RES can cover the continuously increasing energy demand. Although, the RES offers clean energy, its periodic nature becomes the main barricade for their implementations in real time which motivated the researchers in combining one or more RES to form hybrid renewable energy system (HRES). Commercially available HRES include solar PV-diesel, solar PV-battery, wind-battery, wind-diesel, solar PV-wind-battery, and solar PV-wind-diesel battery systems (Binayak Bhandari et al., 2015; Binayak Bhandari et al., 2014).

The stand-alone HRES discussed in this paper contains solar PV, wind, micro hydro, diesel generators and batteries. Therefore, the aim of the paper is to design an optimal HRES for reliable and economic load supply. Research work related to optimization of different combination of HRES using various evolutionary algorithms is listed in Ajay Kumar Bansal et.al., 2013; Farshid Mostofi and Masoud Safavi, 2013; Kamaruzzaman Sopian et.al., 2008. The development of numerous meta heuristic algorithms by various researchers around the world over the past two decades has successfully solved these problems with superior convergence characteristics, better solution quality and robustness, eliminating most of the difficulties of classical methods (P.Subbaraj et.al., 2011; P.Subbaraj et.al., 2010).

Grey Wolf Optimization (GWO) algorithm, a recent swarm intelligence meta heuristic algorithm is proposed by Mirjalili et al to solve the non-convex optimization problem. GWO algorithm impersonates the leadership and hunting behaviours of grey wolves in nature and has superior exploration and exploitation ability (Seyedali Mirjalili et.al., 2014). In solving real world problems, the GWO algorithm has the capability of providing better quality solutions and good computational efficiency with few parameters and ease of implementation. These properties have motivated few researchers to implement the GWO algorithm in solving many real time problems. In this paper, GWO algorithm is used to solve the HRES problem to validate its effectiveness over other meta heuristic algorithms. The simulation results show that the GWO algorithm performs better than the previous algorithms in terms of solution quality, convergence efficiency and robustness (Seyedali Mirjalili et.al., 2014).

The rest of the paper is organized as follows: Section 2 describes the mathematical modelling of HRES system. The problem formulation for the chosen HRES system is described in Section 3. The detailed description of GWO algorithm is discussed in Section 4. Section 5 describes the implementation of GWO to the HRES problem. The numerical results and discussion of the proposed algorithm to the chosen test systems are presented in Section 6 and conclusion is drawn in Section 7.

## 2 Hybrid Renewable Energy System (HRES)

A HRES generally comprises of two or more primary renewable energy sources combined with a secondary conventional energy sources and a storage system as a backup system. In this paper, the stand-alone HRES comprises of solar PV, wind turbine and micro-hydro as primary renewable energy sources, diesel generator as the conventional energy source and battery as the storage device. The block diagram of the chosen stand-alone HRES is shown in Fig. 1. (Maamaar Laidi et.al., 2012; Bhandari, B et.al., 2014; Koumarios Antonios 2011).

The mathematical modelling of individual components present in HRES is discussed in this section.

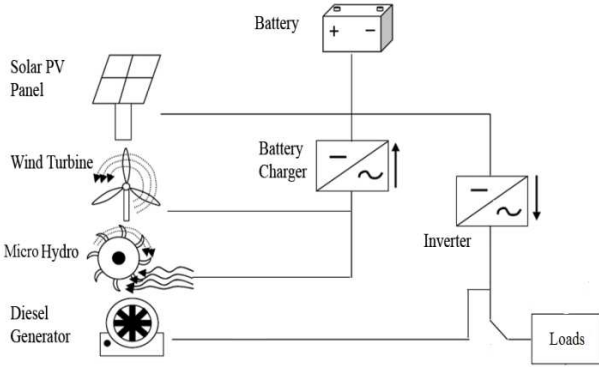

Fig.1. Block diagram of HRES

### 2.1 Solar photovoltaic (solar PV)

The output power produced from the solar PV panels is given by (Koumarios Antonios 2011):

$$P_{pv}(t) = \eta \times A_{pv} \times i(t) \quad (1)$$

where  $P_{pv}(t)$  is the power produced at hour  $t$  by the solar panel in Watts ( $W$ ),  $\eta$  is the energy conversion coefficient in %,  $A_{pv}$  is the area of a single PV panel in  $m^2$  and  $i(t)$  is the isolation at hour in  $W/m^2$ .

### 2.2 Wind turbine

The power output from wind turbine which depends on the velocity of the wind is given by (Koumarios Antonios 2011):

$$P_w(t) = 0.5 \times \eta_{wt} \times \eta_g \times \rho \times C_p \times A \times v^3(t) \quad (2)$$

where  $P_w(t)$  is the power produced at hour  $t$  by the wind turbine in watts ( $W$ ),  $\eta_{wt}$  is the efficiency of the wind turbine in %,  $\eta_g$  is the efficiency of the generator in %,  $\rho$  is the density of air in  $kg/m^3$ ,  $C_p$  is the power coefficient of wind turbine,  $A$  is the wind turbine rotor swept area in  $m^2$  and  $v$  is the velocity of the wind in ( $m/s$ ).

### 2.3 Micro-hydro turbine

The hydro unit plays a crucial role in secure, reliable and profitable operation of power system by supplying for the power uncertainty. The output power from the micro-hydro turbine is given by (Koumarios Antonios 2011):

$$P_h(t) = \eta_h \times g \times \rho_w \times H \times Q(t) \quad (3)$$

where  $P_h(t)$  is the power produced at hour  $t$  by the hydro turbine in  $W$ ,  $\eta_h$  is the efficiency of the hydro turbine in %,  $g$  is the acceleration due to gravity in  $m/s^2$ ,  $\rho_w$  is the density of water in  $kg/m^3$ ,  $H$  is the effective head in  $m$  and  $Q(t)$  is the flow rate of water at hour  $t$  in litres / second ( $l/s$ ).

### 2.4 Battery

The battery gets charged or discharged based on the power produced by the primary renewable energy sources. The total energy produced by the primary energy sources is given by (Koumarios Antonios 2011):

$$P_p(t) = \eta_i \times [N_{pv} P_{pv}(t) + N_w P_w(t)] + N_h P_h(t) \quad (4)$$

where  $P_p(t)$  is the summation of the energy produced by the primary energy sources in  $W$ ,  $\eta_i$  is the efficiency of the inverter in %,  $N_{pv}$ ,  $N_w$  and  $N_h$  are the total number of solar panels, wind turbines and hydro turbines respectively.

The relation between the state of charge (SOC) for the battery between two consecutive hours is given in Eqn.(5) and Eqn.(6)

$$P_b(t) = P_b(t-1)(1-\sigma) + \left( P_p(t) - \left( \frac{P_L(t)}{\eta_i} \right) \right) \eta_b$$

if  $P_p(t) > P_L(t)$  (5)

$$P_b(t) = P_b(t-1)(1-\sigma) - \left( P_L(t) - \left( \frac{P_p(t)}{\eta_i} \right) \right) \eta_b \quad \text{if } P_p(t) < P_L(t)$$

(6)

where  $P_b(t)$  is the available capacity of battery banks at hour  $t$  in  $W$ ,  $\sigma$  is the self-discharge rate of the battery banks,  $\eta_b$  is the efficiency of a battery in %, and  $P_L(t)$  is the demand of the system at hour  $t$  in  $W$ .

### 2.5 Diesel generator

When  $P_p(t) > P_L(t)$  for a particular hour  $t$  and when the battery doesn't have sufficient energy to supply the demand, diesel generator gets operated to generate remaining power. The power generated by diesel generator is,  $P_{dg}(t)$  (Koumarios Antonios 2011).

## 3 Problem formulation

### 3.1 Objective function

The main objective of any HRES is to maximize the utilization of primary energy sources by considering the other factors like financial investment, running cost, reliability and durability of the considered system (Koumarianos Antonios 2011).

### 3.1.1 Minimization of total annual cost of the system

The first objective of selected HRES is to minimize the total annual cost of the system,  $TC_{annual}$  which is given by (Koumarianos Antonios 2011):

$$\min TC_{annual} = \min CC_{annual} + OC_{annual} \quad (7)$$

where  $TC_{annual}$  is the total annual cost in Euro (€),  $CC_{annual}$  is the annual capital cost in € and  $OC_{annual}$  is the annual operational cost in € of the chosen system.

### 3.1.2 Minimization of total dumped power of the system

The second objective of considered HRES is to minimize the total dumped power of the system,  $dump$  which is given by

$$\min dump = \sum_{t=1}^{24} dum(t) \quad (8)$$

where  $dum(t)$  is the power dumped at hour  $t$  which is calculated as

$$dum(t) = P_p(t) + P_{bt} + P_{dg} - P_L(t) \quad (9)$$

## 3.2 Annual capital cost calculation

The annual capital cost of the system consists of the capital cost of the units in the chosen hybrid system which does not require replacement and is given by (Koumarianos Antonios 2011):

$$CC_{annual} = CRF \times CC_{units} \quad (10)$$

where  $CRF$  is the capital recovery factor of the system and  $CC_{units}$  is the summation of capital cost of all the units present in the system in €.

### 3.2.1 Calculation of $CRF$

The  $CRF$  of the system is a ratio to calculate the present value of a series of equal cash flows and is calculated as (Koumarianos Antonios 2011):

$$CRF = \frac{i \times (1+i)^N}{(1+i)^N - 1} \quad (11)$$

where  $i$  is the interest rate in % and  $N$  is the project lifetime in years which are assumed to be 15% and 20 years respectively in this paper.

### 3.2.2 Calculation of $CC_{units}$

The capital cost of all the units present in the chosen HRES system is given by (Koumarianos Antonios 2011):

$$CC_{units} = a + b + c + d + (N_b \times C_b) \quad (12)$$

$$\text{where } a = \sum_{i=1}^{N_{pv}} (C_{pv} \times P_{pvr}), b = \sum_{i=1}^{N_w} (C_w \times P_{wr}), c = \sum_{i=1}^{N_h} (C_h \times P_{hr}),$$

$$d = \sum_{i=1}^{N_d} (C_d \times P_{dr}), N_d \text{ is the number of diesel}$$

generators,  $N_b$  is the number of batteries,  $C_b$  is the capital cost of battery in €,  $C_{pv}$ ,  $C_w$ ,  $C_h$  and  $C_d$  are the cost per kW of generated by solar PV, wind, micro-hydro and diesel generator respectively in €,  $P_{pvr}$ ,  $P_{hr}$  and  $P_{dr}$  are the rated power of solar PV, wind, micro-hydro and diesel generator in W respectively.

## 3.3 Annual operational cost calculation

The annual operational cost for the HRES system is given by (Koumarianos Antonios 2011):

$$OC_{annual} = 365 \times DOC \quad (13)$$

where  $DOC$  is the daily operational cost of the system in € which is the summation of operational cost of batteries, diesel generators, fuel used and renewable energy units which is given by

$$DOC = O_{pv}P_{pvt} + O_hP_{ht} + O_wP_{wt} + O_bP_{bt} + O_dP_{dt} + F_d \times F_t \quad (14)$$

where  $O_{pv}$ ,  $O_h$ ,  $O_b$ ,  $O_d$  and  $F_d$  are the operational cost of solar PV, wind, hydro, diesel generator, battery per kWh and fuel cost respectively in €,  $P_{pvt}$ ,  $P_{wt}$ ,  $P_{ht}$ ,  $P_{dt}$  and  $P_{bt}$  are the total power generated from solar PV, wind, hydro, diesel generator and battery in a day in W and  $F_t$  is the total fuel consumed in a day in liters( $l$ ) which is given by (Koumarianos Antonios 2011):

$$F_t = \sum_{t=1}^{24} F(t) \quad (15)$$

where  $F(t) = 0.246 \times P_d(t) + N_d \times 0.8415 \times P_{drated}$  is the fuel consumption at hour  $t$  in  $l$ .

## 3.3 Design constraints

### 3.3.1 Inequality constraints

a) Number of devices

The number of wind power generation, PV panels, batteries, diesel generators and micro-hydro plants are subjected to following constraints:

$$0 \leq N_w \leq N_{wm}, 0 \leq N_{pv} \leq N_{pvm}, 0 \leq N_h \leq N_{hm},$$

$$0 \leq N_d \leq N_{dm} \text{ and } 0 \leq N_b \leq N_{bm}$$

$$(16)$$

where  $N_{wm}$ ,  $N_{pvm}$ ,  $N_{hm}$ ,  $N_{dm}$  and  $N_{bm}$  are the maximum number of wind turbines, PV panels, hydro turbines, diesel generators and batteries that can be incorporated in the system respectively.

b) Available capacity of battery banks

$$P_{b \min} \leq P_b(t) \leq P_{b \max} \quad (17)$$

where  $P_{b\min}, P_{b\max}$  are the minimum and maximum allowed energy level in the battery banks.

c) Power balance equation

$$P_{pv}(t) + P_w(t) + P_h(t) + P_{b1}(t) + P_d(t) \geq P_L(t) \quad (18)$$

#### 4 Grey Wolf Algorithm (GWO)

Grey wolf optimization (GWO) algorithm is a very recent meta heuristic optimization algorithm inspired by gray wolves is developed and proposed by Mirjalili et al., 2014. The GWO algorithm imitates the hunting and the social hierarchy behaviours of grey wolves. In addition to the advantages of meta heuristic algorithms like simplicity, flexibility, derivative-free-mechanism, and local optima avoidance, the GWO algorithm requires no specific input parameters to be initialized. Also, the GWO algorithm is straight forward, free from computational complexity, and can be easily implemented in any programming languages (Mirjalili et al., 2014).

The interesting fact of grey wolves in GWO algorithm is it possess a very strict social dominant hierarchy as shown in Fig.2. Social dominant hierarchy is employed with the help of four types of grey wolves alpha ( $\alpha$ ), beta ( $\beta$ ), delta ( $\delta$ ) and omega ( $\omega$ ). Leader wolf or alpha ( $\alpha$ ) wolf is responsible for making decisions like hunting, searching, time to wake and so on. The beta ( $\beta$ ) wolf respect and supports alpha ( $\alpha$ ) wolf in decision making, the delta ( $\delta$ ) wolf which always follow  $\alpha$  and  $\beta$  wolves. The wolves which do not come under these category are called as omega ( $\omega$ ) wolves and are used basically as a scapegoat and occupies the lowest level of hierarchy .

Group hunting is another interesting social behavior of grey wolves in addition to the social hierarchy of wolves. The three phases of grey wolf hunting are: (i) Tracking, chasing, and approaching the prey, (ii) Pursuing, encircling, and harassing the prey until it stops moving and (iii) Attack towards the prey (Mirjalili et al., 2014).

##### 4.1 Mathematical modelling of GWO

In this section, the mathematical modelling of GWO algorithm is discussed using the social hierarchy of wolves and group hunting of prey.

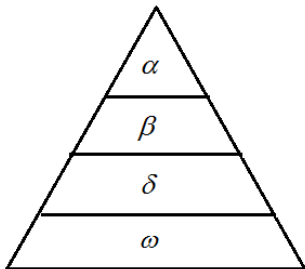

Fig.2 Hierarchy in of grey wolves in GWO algorithm

##### 4.1.1 Social hierarchy

In modelling of GWO algorithm, the different types of wolves are classified based on the fitness value of the problem. The fittest solution is considered as  $\alpha$  wolf ,the second best solution is  $\beta$  wolf , the third best solution is  $\delta$  wolf and the rest of the solutions are  $\omega$  wolves (Mirjalili et al., 2014).

##### 4.1.2 Encircling the prey

As mentioned earlier, the grey wolves encircle the prey during the hunting process. The following two equations are considered to model the encircling behavior of grey wolves (Mirjalili et al., 2014):

$$\vec{C} = \left| \vec{B} \cdot \vec{X}_p(t) - \vec{X}(t) \right| \quad (19)$$

$$\vec{X}(t+1) = \vec{X}_p(t) - \vec{A} \cdot \vec{C} \quad (20)$$

where  $t$  indicates the current iteration in the problem,

$\vec{X}_p(t)$  is the position vector of the prey,  $\vec{X}(t)$  and  $\vec{X}(t+1)$  indicates the position vector of the grey wolf at  $t$  and  $t+1$  respectively and the coefficient vectors

$\vec{A}$  and  $\vec{B}$  are computed using the following equations:

$$\vec{A} = 2 \cdot \vec{a} \cdot \vec{\eta} - \vec{a} \quad (21)$$

$$\vec{B} = 2 \cdot \vec{r}_2 \quad (22)$$

where  $\vec{\eta}$  and  $\vec{r}_2$  are random vectors between  $[0, 1]$

and  $\vec{a}$  is a factor which decreases linearly from 2 to 0 as iteration increases.

Inside the space, a grey wolf can update its position in and around the prey in any random location using Eqs. (21) and (22). The same concept can be extended to a search space with  $n$  dimensions.

##### 4.1.3 Hunting

All the grey wolves can recognize the location of prey to encircle and hunt them. The positions of the wolf are updated around the prey using the following equations (Mirjalili et al., 2014):

$$\vec{C}_\alpha = \left| \vec{B}_1 \cdot \vec{X}_\alpha(t) - \vec{X}(t) \right|, \vec{C}_\beta = \left| \vec{B}_2 \cdot \vec{X}_\beta(t) - \vec{X}(t) \right|,$$

$$\vec{C}_\delta = \left| \vec{B}_3 \cdot \vec{X}_\delta(t) - \vec{X}(t) \right| \quad (23)$$

$$\vec{X}_1(t) = \vec{X}_\alpha(t) - \vec{A}_1 \cdot \vec{C}_\alpha, \quad \vec{X}_2(t) = \vec{X}_\beta(t) - \vec{A}_2 \cdot \vec{C}_\beta,$$

$$\vec{X}(t) = \vec{X}_\delta(t) - \vec{A}_3 \cdot \vec{C}_\delta \quad (24)$$

$$\vec{X}(t+1) = \frac{\vec{X}_1(t) + \vec{X}_2(t) + \vec{X}_3(t)}{3} \quad (25)$$

where  $\vec{X}_\alpha(t)$ ,  $\vec{X}_\beta(t)$  and  $\vec{X}_\delta(t)$  are the position of first, second and third best fitness value .

Using the above equations, the alpha, beta and delta grey wolves estimates the positions of the prey and other grey wolves randomly update their positions around the prey.

#### 4.1.4 Attacking prey (Exploitation)

The above sections deals with how the grey wolves hunt the prey when it stop moving. The

parameters  $a$  and  $A$  are used to mathematically express the pathway for approaching the prey by grey

wolves. The parameter  $a$  is linearly decreasing from 2 to 0 and fluctuation of parameter  $A$  also gets decreased with  $a$  (Mirjalili et al., 2014).

#### 4.1.5 Searching the prey (Exploration)

The positions of alpha, beta and delta grey wolves helps in optimum search of algorithm. These wolves diverge from each other to search the prey and converge together to attack the prey. The parameters which directly influence this exploration behavior are  $A$  and  $B$  .

Mathematically, when  $A$  is greater than 1 or less than -1, the three grey wolves diverge in search of prey. Therefore, from the above discussion we can able to conclude that GWO algorithm shows more random behavior which favours the exploration and avoidance of local optima.

The general flowchart to describe the GWO algorithm is shown in Fig. 3

### 5 Implementation of GWO algorithm to HRES problem

The general implementation of GWO algorithm to solve HRES problem for different cases is described as follows:

**Step 1:** The input data for the chosen test system is read to compute the total annual cost or total dumped power of the system.

**Step 2:** GWO parameters i.e., population size  $N$  and select the stopping criteria are initialized.

**Step 3:** The number of design variables,  $D$  required for the test system is selected and are initialized. According to the population size, the design variable for the test system is generated randomly using Eqn. (26).

$$P_{ij} = P_{i,\min} + rand(1) \times (P_{i,\max} - P_{i,\min}) \quad (26)$$

where  $j = 1, 2, \dots, N$  ,

Therefore, the matrix of  $D \times N$  is initialized using Eqn.(26).

**Step 4:** The fitness of each population is calculated using  $F_T$  . After sorting the fitness value in descending order

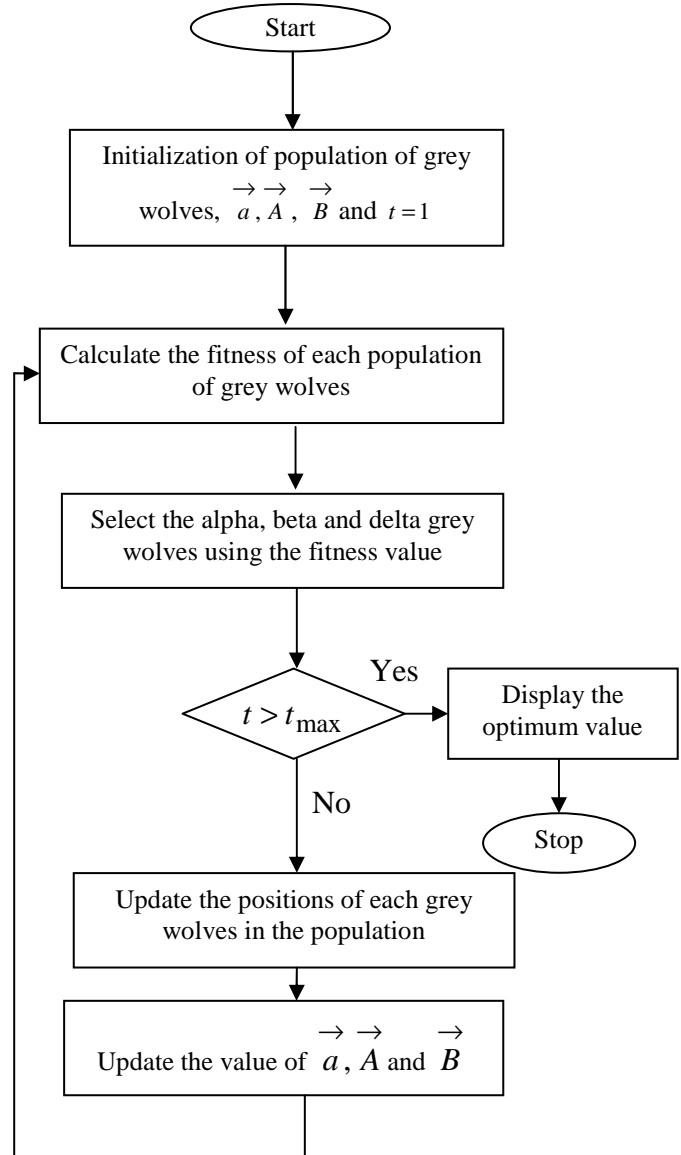

Fig. 3 Flowchart of GWO

alpha ( $\alpha$ ), beta( $\beta$ ) and delta( $\delta$ )grey wolves are determined using Eqn. (27).

$$F_{T\alpha} = F_T(N), F_{T\beta} = F_T(N-1), F_{T\delta} = F_T(N-2) \quad (27)$$

**Step 5:** The design variables corresponding to  $F_{T\alpha}$ ,

$F_{T\beta}$  and  $F_{T\delta}$  are saved as  $\vec{P}_\alpha(t)$ ,  $\vec{P}_\beta(t)$  and respectively.

**Step 6:** Using Eqn. (21) and Eqn. (22),  $A_i$  and  $B_i$ ,  $i = 1, 2$  and  $3$  are determined

**Step 7:** The position of each grey wolf in the population gets updated using Eqn. (23) to Eqn. (25).

**Step 8:** Proper termination criterion is selected  
Step 4 to step 7 will be repeated till the termination criteria is reached by the algorithm

## 6 Results and Discussion

### 6.1 Case Study

A typical farming village of Western Ghats in Kerala, India is considered as a case study to determine the optimal combination of HRES. Kerala is one of the Indian state located on the Malabar coast of south west India. The village which comprises of 120 families with a population of over 600 is located around 110km away from the nearest local town. The mode of transportation is restricted to jeeps and distance to the existing grid line is around 15km. Complexity exist in extending the grid to the village due to its geographical location (S.Ashok 2007).

About 35% of the population receives power using 6.25 kVA diesel generator (DG) which operates about six hours a day during peak hours and the working hours is extended during emergencies and festival seasons. The different electrical loads existing in the village are compact fluorescent lamps, fan and radio set. It has been estimated that there exists potential of renewable energy sources like several water streams, wind and solar energy (S.Ashok 2007).

The hourly load profile for a particular day of the village, solar radiation, ambient temperature and wind speed is shown in Fig. 4. The water flow for the micro-hydro source is 35 l/s with head of 45 m (S.Ashok 2007).

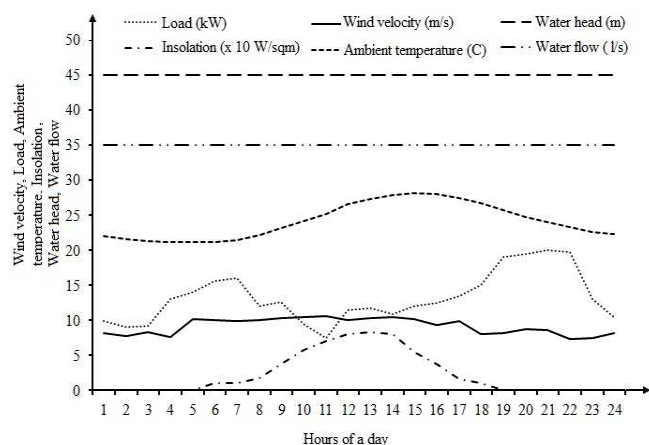

**Fig.4** Essential data obtained for a village

Although there exist high potential of renewable energy sources, its application as standalone units will not be efficient for an uninterrupted power supply due to its seasonal and non-linear variations. HRES which integrates the available renewable energy sources

eliminates the fluctuations of sources, increase energy production and reduce the usage of energy storage. In this paper, GWO algorithm is used to determine the optimal combination of HRES based on the users objective to meet the required demand. The GWO algorithm for the considered test system has been implemented in MATLAB 2013a on Intel (R) Core (TM) i7 - 3517U CPU 2.40 GHz with 8G-RAM.

### Case 1: To minimize the total cost of the system

The primary objective of any HRES is to determine the optimal combination of renewable sources by minimizing the total cost of the system and meeting the demand. The total cost of the system is calculated using the Eqn.(7) to Eqn. (18) and the economical parameters used for calculating the total cost is listed in S.Ashok 2007. The combination of energy sources and their corresponding total cost obtained using different algorithms is listed in Table.1. The minimum cost achieved by GWO algorithm is 6880.5 € and the power generated by different energy sources for each hour using GWO algorithm is shown in Fig. 5.

**Table 1.** Optimal combination of HRES using different algorithm for Case 1

Algorithms	$N_{pv}$	$N_h$	$N_w$	$N_b$	$N_d$	Total cost in €	Total dumped power in kW
GA	32	1	3	14	0	11569.8	248.7
PSO	62	1	1	10	0	10722.6	94.6
DE	39	1	0	8	2	9151.0	26.6
SADE	0	1	1	10	0	7053.7	89.1
<b>GWO</b>	<b>0</b>	<b>1</b>	<b>0</b>	<b>8</b>	<b>2</b>	<b>6880.5</b>	<b>23.4</b>

### Case 2: To minimize the total dumped power of the system

From Table 1, we can infer that even for the optimal cost, there exist a excess generation of 23.4 kW. Though the excess generation is of small value, management of these excess power is difficult in real world implementation. Hence to overcome such difficulties the algorithm is implemented to generate the optimal combination of HRES by minimizing this dumped excess power. In this case, the inequality constraints given in Eqn. (18) becomes an equality constraint as given in Eqn. (25).

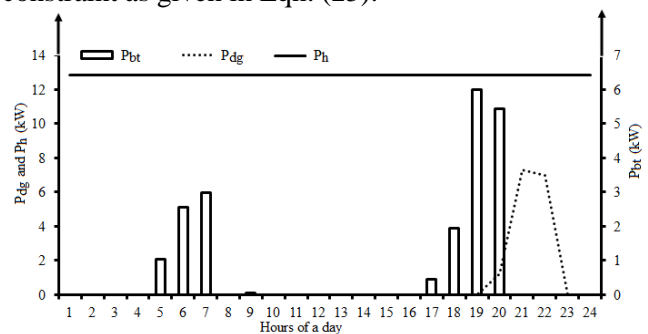

**Fig. 5** Real Power generated from different sources using GWO for case 1

$$P_{pv}(t) + P_w(t) + P_h(t) + P_{b1}(t) + P_d(t) = P_L(t)$$

(25)

The combination of energy sources and their corresponding minimum cost achieved by different algorithm by reducing the dumped power is given in Table 2. Figure 6 shows the power generated from various sources.

### Case 3: Considering environmental constraints

Efficiency of each renewable energy sources depends on the environmental condition and geographical location of the place where it has been installed. Hence, the proper choice of renewable energy source based on the location becomes inevitable.

**Table 2** Optimal combination of HRES using different algorithm for case 2

Algorithms	$N_{pv}$	$N_h$	$N_w$	$N_b$	$N_d$	Total cost in €	Total dumped power in kW
GA	407	0	0	10	5	45767.12	0
PSO	175	0	1	11	4	26557.13	0
DE	168	0	1	11	4	26108.45	0
SADE	100	0	1	10	4	22009.19	0
<b>GWO</b>	<b>37</b>	<b>0</b>	<b>1</b>	<b>10</b>	<b>4</b>	<b>18370.56</b>	<b>0</b>

In this section, using the priority based technique, the HRES problem is solved. Three different cases are studied in this section (i) Priority 1 - Fixing  $N_{pv}$ , (ii)

Priority 2 - Fixing  $N_h$  and (iii) Priority 3 - Fixing  $N_w$

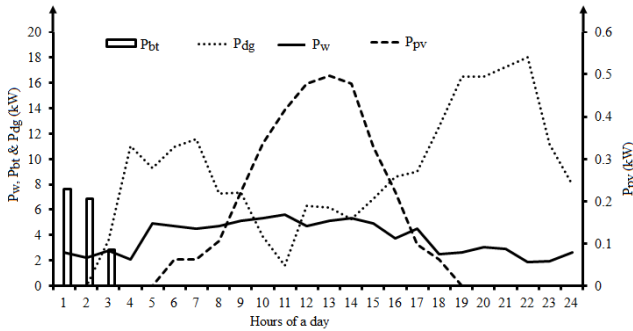

**Fig. 6** Real Power generated from different sources using GWO for case 2

#### (i) Priority 1 - Fixing $N_{pv}$

The number of solar PV panels for the considered location is fixed to 100. Now, the GWO algorithm is implemented to determine the optimal combination of wind and micro-hydro turbines which will meet the demand along with the fixed solar PV panels. The optimal combination of renewable energy sources along with the total cost of the system using different algorithm is listed in Table 3. The power generated by different energy sources for each hour using GWO algorithm is shown in Fig. 7.

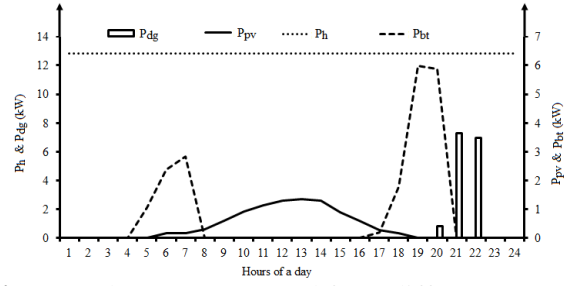

**Fig. 7** Real Power generated from different sources using GWO for case 3

#### (ii) Priority 2 - Fixing $N_h$

The number of hydro plants for the considered location is fixed to 1 and the HRES problem is solved using GWO algorithm to meet the demand of the system. Table 4 list the optimal combination of energy sources with the total cost of the system

**Table 3.** Optimal combination of HRES using different algorithms when  $N_{pv} = 100$

Algorithms	$N_{pv}$	$N_h$	$N_w$	$N_b$	$N_d$	Total cost in €	Total dumped power in kW
GA	100	2	2	0	0	16871.84	462.9151
PSO	100	2	0	0	0	13671.91	291.5126
DE	100	1	1	10	0	13069.86	98.1356
SADE	100	1	0	8	2	12861.45	31.68823
<b>GWO</b>	<b>100</b>	<b>1</b>	<b>0</b>	<b>8</b>	<b>2</b>	<b>12861.45</b>	<b>31.68823</b>

. The power generated by different energy sources for each hour using GWO algorithm is shown in Fig. 8.

#### (iii) Priority 3 - Fixing $N_w$

In this case for the considered location, the number of wind turbines is limited to 1 and the proposed algorithm is used to obtain the optimal combination of micro hydro and solar PV for the described HRES problem. Table 4 list the optimal

**Table 4.** Optimal combination of HRES using different algorithms when  $N_h = 1$

Algorithms	$N_{pv}$	$N_h$	$N_w$	$N_b$	$N_d$	Total cost in €	Total dumped power in kW
GA	119	1	1	11	0	14352.24	99.8824
PSO	21	1	0	8	2	8091.798	25.1075
DE	5	1	1	10	0	7342.485	89.5958
SADE	3	1	0	8	2	7051.445	23.6467
<b>GWO</b>	<b>0</b>	<b>1</b>	<b>0</b>	<b>8</b>	<b>2</b>	<b>6880.459</b>	<b>23.4146</b>

combination of energy sources with the total cost of the system. The power generated by different energy sources for each hour using GWO algorithm is shown in Fig. 9.

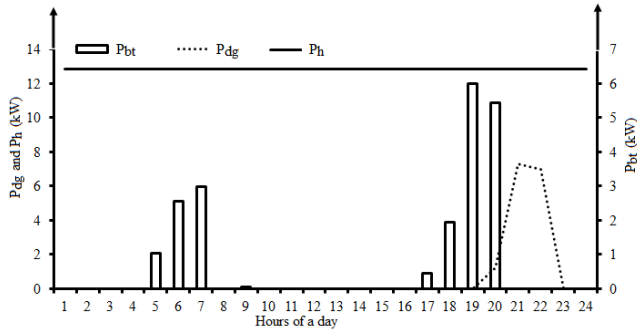

**Fig. 8** Real Power generated from different sources using GWO for case 4

### 6.2 Result Analysis

The number of grey wolf population which depends of problem dimension and complexity of the problem, affects the convergence and search capability of GWO algorithm..

**Table 5.** Optimal combination of HRES using different algorithms when  $N_w = 1$

Algorithms	$N_{pv}$	$N_h$	$N_w$	$N_b$	$N_d$	Total cost in €	Total dumped power in kW
GA	92	1	1	10	0	12569.48	97.0743
PSO	8	1	2	0	0	9661.327	368.8392
DE	2	1	2	0	0	9313.361	368.2932
SaDE	0	1	2	0	0	9197.773	368.1109
<b>GWO</b>	0	1	1	10	0	7053.734	89.1488

An optimal choice of population size is necessary as large value makes an algorithm slow and computationally inefficient and small value leads to local minima than to the global minima. In order to demonstrate the performance of GWO algorithm, the algorithm has been executed 50 test runs for different population sizes for different objective functions and the obtained solutions are presented in Fig. 10. It can be inferred from Fig. 10, that for all the cases the optimal population size is fixed to 100. The convergence characteristics of different algorithms for different objective functions is shown in Fig. 11 to Fig. 15.

The search agents in GWO which has good computational and search mechanism explores the promising regions of the solution space and determine the optimal solution quickly.

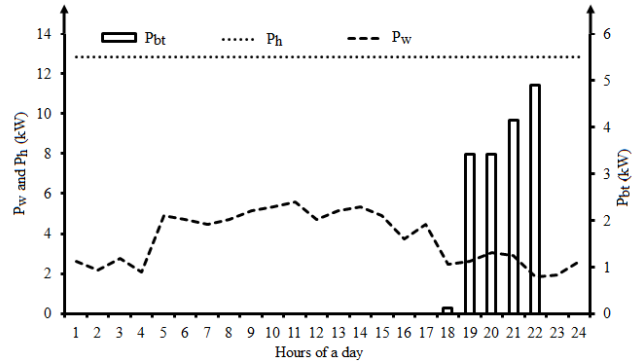

**Fig. 9** Real Power generated from different sources using GWO for case 5

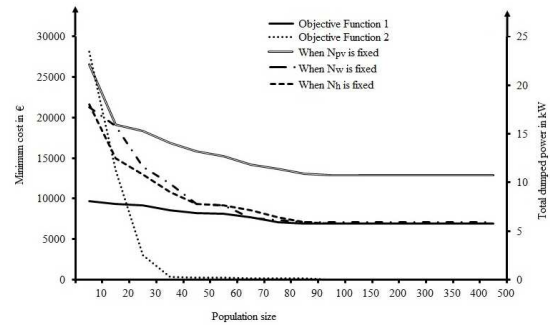

**Fig. 10** Optimal value vs Population size

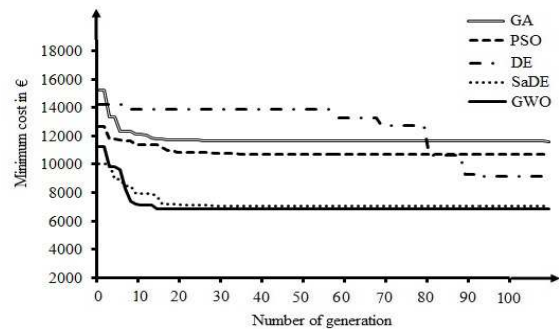

**Fig. 11** Convergence characteristics of Case 1

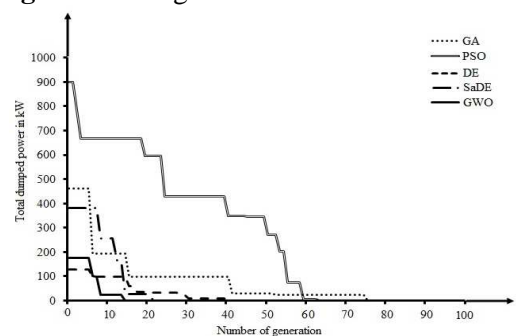

**Fig. 12** Convergence characteristics of Case (ii)

Due to the proper selection of number of grey wolf population and inherent characteristics, the GWO algorithm attains the global solution faster when compared to other algorithms and makes it more efficient, robust and consistent



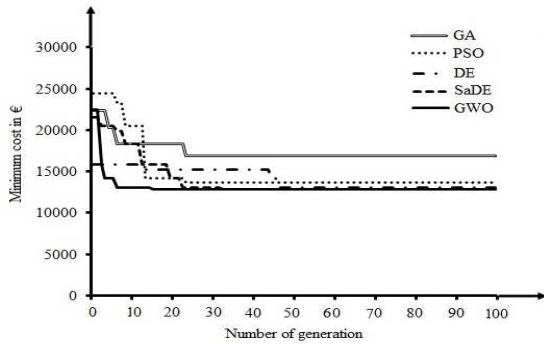

**Fig. 13** Convergence characteristics when  $N_{pv} = 100$

In GWO, due to the inherent randomness involved in the algorithm to initialize the grey wolf, performance and strength of the algorithm cannot be judged through a single trial and which can be evaluated through number of test runs.

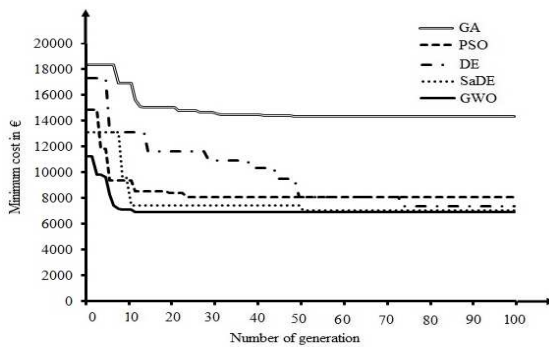

**Fig. 14** Convergence characteristics when  $N_h = 1$

Many test runs with different initial population values were performed to test the robustness or the consistency level of the GWO algorithm. The statistical analysis of the solution attained by the GWO algorithm for different case studies for 100 different trials is shown in Fig. 16.

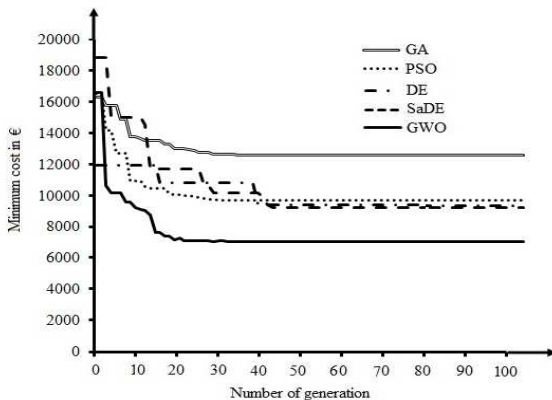

**Fig. 15** Convergence characteristics when  $N_w = 1$

The statistical results presented in the section indicates that GWO outperforms many algorithms as the algorithm allocates exactly half of the generations to both exploration ( $|A| > 1$ ) and exploitation ( $|A| < 1$ ) behavior which leads in determining the diverse solution space during algorithm process.

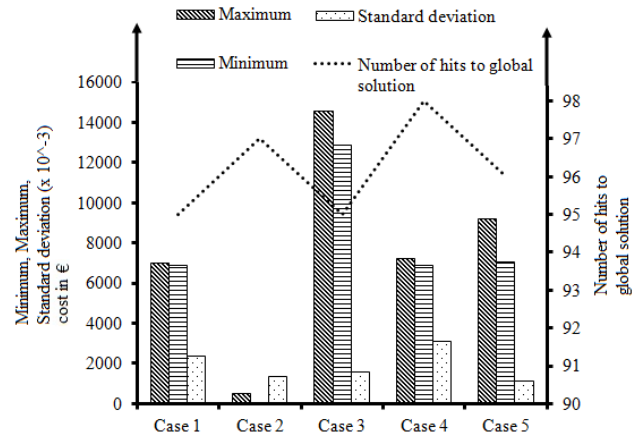

**Fig. 16** Statistical analysis of the system

Also, the parameter  $B$  randomly forces the search agents to take random steps towards the global solution rather than the sub-optimal solution. These adaptive parameters is the main reason for the success of GWO algorithm. In addition, in GWO in every generation the best three solutions are saved which also guides the search agents to exploit the most promising regions of solution space. These are the reasons which assist the GWO algorithm to provide good exploration, exploitation, local optima avoidance and fast convergence simultaneously.

## CONCLUSION

This paper presents a novel GWO algorithm in solving HRES problem by taking the real time data from a typical farming village of Western Ghats in Kerala, India The effectiveness, feasibility and robustness of the GWO algorithm has been investigated on HRES problems with two different objective functions (i) to reduce the total cost of the system and (ii) to reduced the dumped power in the system. Tests were carried on systems with different kinds of constraints. The simulation results show that the proposed algorithm has succeeded in achieving minimum total cost and mini mum dumped power with minimum cost and the statistical results were compared with best known algorithms. The success of GWO algorithm on the test system illustrates the efficiency and robustness of the GWO algorithm in solving complex real world problems.

## REFERENCES

Binayak Bhandari, Kyung-Tae Lee, Gil-Yong Lee, Young-Man Cho, Sung-Hoon Ahn (2015), "Optimization of Hybrid Renewable Energy Power System: A Review," *Int. J of Precision Engineering and Manufacturing-Green Technology*, Vol. 2, Issue 1, pp: 99-112.

Binayak Bhandari, Kyung-Tae Lee, Caroline Sunyong Lee, Chul-Ki Song, Ramesh K. Maskey, Sung-Hoon Ahn (2014), "A novel off-grid hybrid power system comprised of solar photovoltaic, windand hydro energy sources," *Applied Energy*, Vol. 133, pp: 236 – 42.

Ajay Kumar Bansal, Rajesh Kumar, and R. A. Gupta (2013), "Analysis and Power Management of a Small Autonomous Hybrid Power System (SAHPS) Using Biogeography Based Optimization (BBO) Algorithm", *IEEE Trans. Smart Grid*, Vol.4, pp:638-648

Farshid Mostofi, Masoud Safavi (2013), " Application of ABC Algorithm for Grid - Independent Hybrid Hydro - Photovoltaic / Wind / Fuel cell power generation system considering cost and reliability" *Int. J. Renewable Energy Research*, Vol.3, No. 4.

Kamaruzzaman Sopian, Azami Zaharim, Yusoff Ali, Zulkifli Mohd Nopiah, Juhari Ab. Razak, Nor Salim Muhammad (2008), "Optimal Operational Strategy for Hybrid Renewable Energy System Using Genetic Algorithms" *WSEAS Trans. Mathematics*, Vol.7, pp: 130- 140

P. Subbaraj, R. Rengaraj, S. Salivahanan (2011), "Enhancement of Self-adaptive real-coded genetic algorithm using Taguchi method for Economic dispatch problem," *Applied Soft Computing*, Vol. 11, Issue 1, , pp: 83–92.

P. Subbaraj, R. Rengaraj, S. Salivahanan, T.R. Senthikumar, (2010) "Parallel particle swarm optimization with modified stochastic acceleration factors for solving large scale economic dispatch problem," *Int. J. Elec. Power & Energy*, vol. 32, Issue 9, pp: 1014 –23.

Seyedali Mirjalili, Seyed Mohammad Mirjalili, Andrew Lewis (2014), "Grey wolf optimizer," *Advances in Engineering software*, vol. 69, pp. 46 - 61.

Maamar Laidi, Salah Hanini, Brahim Abbad, Nachida Kasbadji Merzouk, Mohamed Abbas (2012), " Study of a solar PV - Wind - Battery Hybrid Power System for a remotely located region in the southern Algerian sahara: Case of refrigeration," *J. Innovations in Renewable Energy*, pp:30 - 38.

Bhandari, B., Poudel, S. R., Lee, K.-T.and Ahn, S.-H., (2014) "Mathematical Modeling of Hybrid Renewable Energy System: A Review on Small Hydro-Solar-Wind Power Generation," *Int. J. Precis. Eng. Manuf.-Green Tech.*, vol. 1, No. 2, pp. 157-173.

Koumarianos Antonios (2011) *Simulation, design study and optimization of small hybrid RES energy system for electrification of remote communications*. Diploma Thesis, National technical university of Athens.

Krishna Teerth Chaturvedia, Manjaree Panditb, Laxmi Srivastava (2009) , "Particle swarm optimization with time varying acceleration coefficients for non-convex economic power dispatch," *Electrical Power & Energy Systems*, vol. 31, pp.249-257.

Priyanka Roy, Pritam Royb, Abhijit Chakrabartib (2013), "Modified shuffled frog leaping algorithm with genetic algorithm crossover for solving economic load dispatch problem with valve-point effect," *Applied Soft Computing*, vol.13, pp.4244-4252.

S. Ashok (2007), "Optimised model for community-based hybrid energy system", *Renewable Energy*, vol. 32, Issue 7, pp: 1155-64.