

SIMULATION AND EXPERIMENTAL ASSESSMENT OF POSITIVE OUTPUT TRIPLE LIFT LUO CONVERTER WITH DIFFERENT VARIOUS CONTROLLERS

N. DHANASEKAR

Associate Professor
Department of Electrical and Electronics Engineering,
A.V.C College of Engineering,
Mayiladuthurai, India
ghanasekar@avccengg.net

G. GANESAN SUBRAMANIAN

Assistant Professor,
E.G.S. Pillay Engineering College,
Nagapattinam, India
ganesan@egspec.org

G. SUNDARAVADIVEL

Assistant Professor,
E.G.S. Pillay Engineering College,
Nagapattinam, India

G. HARI NARAYANAN

Assistant Professor,
E.G.S. Pillay Engineering College,
Nagapattinam, India

Abstract: *The voltage lifting method is utilized in power electronic circuit. Applying this technique effectively overcomes the effects of parasitic elements and greatly increases the output voltage. Positive Output Triple-Lift Luo converters (POTLLC) are series of new DC-DC step-up converters; POTLLC circuit is derived from positive output elementary Luo converter by adding the lift circuit three times. These converters perform DC-DC voltage-increasing conversion with high power density, high efficiency and cheap topology in simple structure. TMS320C242 Digital Signal Processor has many special features to implement intelligent control algorithms in real time. Hence in this research work, design and hardware implementation of controllers have been carried out using TMS320C242 DSP for the POTLLC. The simulation and experimental results are presented and the performance evaluation of the PI, Fuzzy and Neural controller for Triple-Lift Luo Converter is compared under supply voltage disturbance load disturbances.*

Keywords— *Fuzzy logic controller, Positive output Triple-Lift Luo converter, PI controller, Neural controller.*

1. Introduction.

DC-DC converters accept DC input voltage at one level and produce DC output voltage at another level [1-5]. Voltage Lift technique is applied in the periodical switching circuit. Usually, a capacitor is charged during switch-on by source voltage, this charged capacitor

voltage is the output voltage during switch-off period. For DC-DC converters with constant output voltage, it is always desirable that the output voltage remains unchanged in both steady state and transient operations whenever the supply voltage and/or load current are disturbed. DC-DC converters are generally divided into two groups: hard switching converters and soft-switching converters. In hard-switching converters, the power switches cut off the load current within the turn-on and turn off times under the hard switching conditions. The output voltage is controlled by adjusting the on time of the power switch, which in turn adjusts the width of a voltage pulse at the output. This is known as PWM control. The commonly used control methods for DC-DC converters are pulse width modulated (PWM) voltage mode control, PWM current mode control and PID controller. These conventional controllers are unable to perform satisfactorily under large parameter or load variation. Fuzzy logic control and neuro control are work very well for nonlinear, time variant and complex systems, this research work presents the control of positive output Triple- Lift Luo Converter using FLC, Neural controllers and compared with PI controller [6-15].

2. Analysis of negative output triple –lift Luo converter.

The POTLLC circuit is shown in Fig.1. Switches are power MOSFET device. They are driven by a pulse-width-modulated (PWM) switching signal with

repeating frequency f and conduction duty k . The switch repeating period is $T = 1/f$, so that the switch-on period is kT and switch-off period is $(1-k)T$.

The load is resistive, the combined inductor $L = L_1 L_2 / (L_1 + L_2)$; the normalized load is $Z_N = R/fL$. The converter consists of a pump circuit S-L₁-C-D and a low-pass filters L₂.C₀, and lift circuit. The pump inductor L₁ transfers the energy from the source to capacitor C during switch-off and then the stored energy on the capacitor C is delivered to load R during switch-on. Therefore, if the voltage V₀ should be correspondingly higher. When the switch S turned off, the current i_D flows through the free-wheeling diode D. This current descends in whole switching-off period $(1-k)T$. If current i_D does not become zero before switch S turned on again, this working state is defined as continuous mode. If current i_D becomes zero before switch S turned on again, this working state is defined as discontinuous mode. The triple-lift LUO circuit consist of two static switches S and S₁, four inductors L₁, L₂, L₃ and L₄, five capacitors C, C₁, C₂, C₃ and C₀, and five diodes. Capacitors C₁, C₂, and C₃ perform characteristic functions to lift the capacitor voltage V_C by three times of source voltage V₁, L₃ and L₄ perform the function as ladder joints to link the three capacitors C₁, C₂, and C₃ and lift the capacitor voltage V_C up. Current $i_{C1}(t)$, $i_{C2}(t)$, $i_{C3}(t)$ are exponential functions. They have large values at the moment of power on, but they are small because $V_{C1} = V_{C2} = V_{C3} = V_1$ in steady state. The circuit parameters of the chosen Luo converter is listed in Table.1

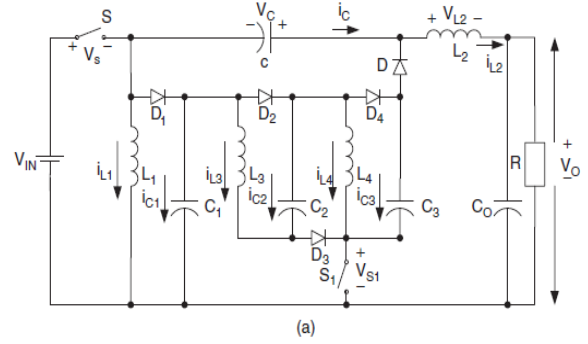

Fig.1. Positive output Triple –Lift Luo Converter.

TABLE I CIRCUIT PARAMETER OF TRIPLE LIFT LUO CONVERTER

Parameters	Symbol	Values
Input voltage	V _{in}	10 V
Output voltage	V _o	60V
Inductors	L ₁ -L ₂ -L ₃ -L ₄	330μH
Capacitors	C ₀ -C ₁ -C ₂ -C ₃ -C	22μf/60V
Load resistance	R	10Ω
Switching frequency	f _s	50KHZ
Duty ratio	D	0.5

3. Design of PI controller.

The function of a PI controller is to receive the actual output voltage from the converter is measured and compares it with the reference voltage and to produce the error signal so as to drive the converter to the desired value. The main function of PI controller is to reduce the peak overshoot and make steady state error zero. PI controller settings K_p and T_i are designed using Ziegler –Nichols tuning technique based on the converter's open loop step response. Converters are modeled using the MATLAB-SIMULINK and PI control is developed using the control system toolbox. Errors in the output voltage and duty cycle of the MOSFET are respectively the input and output of the PI controller.

4. Design of fuzzy logic controller.

The block diagram of the fuzzy logic control scheme for the POTLLC is shown in Fig.2. The output voltage of the Luo converter is compared with the reference voltage. After comparison, the error (e) and the change in error (ce) are calculated and are given as inputs to the fuzzy controller. In this work, the error is normalized to a per-unit value with respect to the reference voltage, which helps in using the fuzzy controller for any reference voltage. The fuzzy controller will attempt to reduce the error to zero by changing the duty cycle of switching signal. The fuzzy controller is divided into five modules: fuzzifier, data base, rule base, decision maker and defuzzifier. Various steps in the design of FLC for chosen Luo converter are stated below:

The output voltage and current are

$$V_0 = \frac{3}{1-k} V_i$$

$$\text{and } I_0 = \frac{1-k}{3} I_i$$

The Voltage transfer gain in continuous mode is

$$M_T = \frac{V_0}{V_i} = \frac{3}{1-K}$$

Other average voltages:

$$V_C = V_0 ; \quad V_{C1} = V_{C2} = V_{C3} = V_i$$

Other average currents:

$$I_{L2} = I_0 ; \quad I_{L1} = \frac{k}{1-k} I_0$$

$$I_{L3} = I_{L4} = I_{L1} + I_{L2} = \frac{1}{1-k} I_0$$

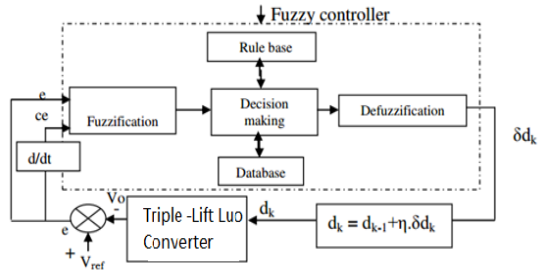

Fig.2. Block Diagram of fuzzy logic control for a Positive output Triple- Lift Luo converter.

A. Fuzzification

FLC uses linguistic variables instead of numerical variables. The process of converting a numerical variable (real number or crisp variables) into a linguistic variable (fuzzy number) is called fuzzification. In the present work, the error and change in error of voltage are fuzzified. Seven linguistic fuzzy sets with triangular membership function are as shown in Fig. 3. The seven fuzzy variables for ‘error’, ‘change in error’ and change in the duty cycle are Negative Big (NB), Negative Medium (NM), Negative Small (NS), Zero (Z), Positive Big (PB), Positive Medium (PM) and Positive Small (PS).

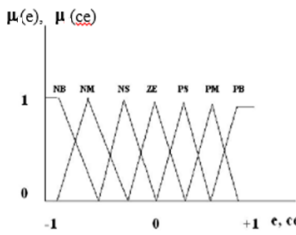

Fig. 3 Membership functions for e, ce

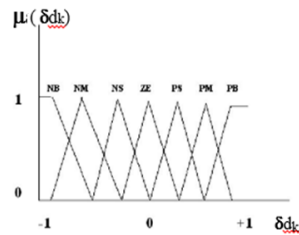

Fig. 4 Membership functions for δd_k

B. Rule Table and Inference Engine

The derivation of the fuzzy control rules is heuristic in nature and based on the following criteria:

1. When the output of the converter is far from the set point, the change of duty cycle must be large so as to bring the output to the set point quickly.
2. When the output of the converter is approaching the set point, a small change of duty cycle is necessary.
3. When the output of the converter is near the set point and is approaching it rapidly, the duty cycle must be kept constant so as to prevent overshoot.
4. When the set point is reached and the output is still changing, the duty cycle must be changed a little bit to prevent the output from moving away.
5. When the set point is reached and the output is steady, the duty cycle remains unchanged and when the output is above the set point, the sign of the change of duty cycle must be negative and vice versa.

According to these criteria, a rule table is derived and is shown in Table II. From the rule table, the rules are manipulated as follows: If error is NM, and change in error is NS, then output is NB.

TABLE II RULE TABLE

$\begin{matrix} ce \\ e \end{matrix}$	NB	NM	NS	ZE	PS	PM	PB
NB	NB	NB	NB	NB	NM	NS	ZE
NM	NB	NB	NB	NM	NS	ZE	PS
NS	NB	NB	NM	NS	ZE	PS	PM
ZE	NB	NM	NS	ZE	PS	PM	PB
PS	NM	NS	ZE	PS	PM	PB	PB
PM	NS	ZE	PS	PM	PB	PB	PB
PB	ZE	PS	PM	PB	PB	PB	PB

B. Defuzzification

The FLC produces the required output in a linguistic variable (fuzzy number). According to real-world requirements, the linguistic variables have to be transformed to crisp output. Center of gravity method is used for defuzzification in this work. The defuzzified output is the change in duty cycle.

$$\delta d_k = \frac{\sum_{i=1}^4 w_i m_i}{\sum_{i=1}^4 w_i} \quad (6)$$

5. Design of neural controller.

Considering the inherent nonlinearity of the Luo converter, the output dependence of the circuit parameters that can change continuously and the demands on regulation and response time normally required for a power supply, it is clear that the design based on linear models does not meet the requirements. Artificial neural networks have many characteristics similar to the human brain are capable of learning from experience, generalization, abstracting essential characteristics from inputs high tolerance to faults, real time operation, etc. Therefore, neural networks offer many advantages for the control of Luo converter. The actual output voltage is fed back and is compared with reference voltage. After comparison, error and the change in error are calculated and are given as input to the controller. The neural controller attempts to reduce the error to zero by changing the duty cycle of switching signal.

MATLAB/Simulink model of the Triple-Lift Luo converter was developed and simulated with Fuzzy Logic Controller using Fuzzy Tool Box. From the simulation, error, change in error and duty cycle was acquired. These data were used to train the neuro controller. Then the closed loop operation was simulated with neuro controller using MATLAB NN Tool Box to achieve the desired performance. In this work Quasi-Newton back-propagation algorithm is employed to update weights Mean Square Error (MSE) is the performance criterion that evaluates the network according to the mean of square of error between the target and computed output. LEARNGDM learning function which has the gradient descent with momentum weight / bias learning function has been used in this work. Learning occurs according to the learning parameters

The activation functions are bipolar sigmoid type and linear activation function are used for hidden and output

layers respectively. There is no general procedure to determine the exact size of the neural network. However, the size of the network developed in this work showed itself satisfactory as far as the output voltage regulation is concerned. Trials have been carried out to obtain maximum accuracy with minimum number of neurons per layer.

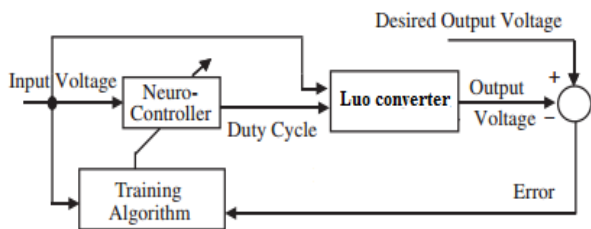

Fig. 5. Block Diagram of Neuro for Luo converter.

6. Simulation and hardware results.

Fig.6 shows the measured responses of the output voltage with PI controller when the supply voltage is changed to $\pm 25\%$ of rated voltage at 0.035sec and 0.07sec. For the supply change from 10V to 12.5V and $R = 10\Omega$, the output voltage is regulated within 6msec and the %peak overshoot is 10. When the supply voltage is changed from 12.5V to 10V, the settling time is 8msec with 8.33% peak overshoot.

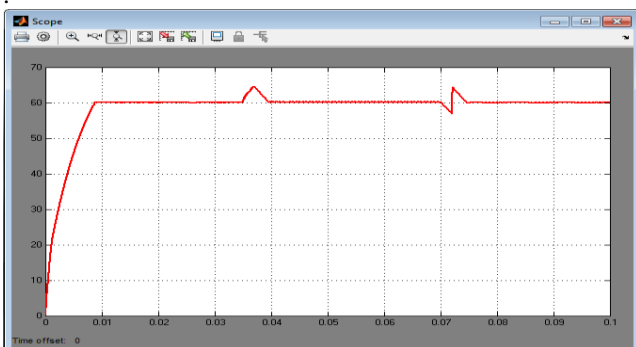

Fig. 6. Line regulation of POTLLC with PI controls Step change of supply voltage from 10-12.5V at 0.035sec and 12.5- 10v at 0.07sec.

Fig.7 shows the start up as well as transients of the converters with fuzzy controller under small signal step disturbances in supply. A 25% step increase in the input voltage and vice versa applied at $t=35\text{msec}$ and $t=70\text{msec}$, the line disturbances are rejected within 3msec for a step change of 10V-12.5V and 7msec for a step change of 12.5V-10V. The peak overshoots are 8.33% and 5.83% for $\pm 25\%$ step change in the rated supply voltage. For the neuro controller Fig.8, it can be seen that for the input supply voltage stepping-up from 10V to 12.5V (25% of rated supply voltage) at 0.035 sec, the %peak overshoot and settling time are 8.03 and 3msec and for the supply stepping down from 12.5V to 10V (25% decrease of rated supply voltage) at 0.07sec, the %peak overshoot and settling time are 3.33 and 4msec.

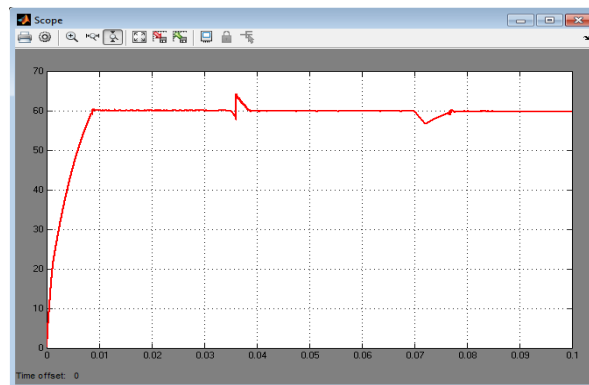

Fig. 7. Line regulation of POTLLC with Fuzzy controller Step change of supply voltage from 10-12.5V at 0.035 sec and 12.5- 10v at 0.07sec.

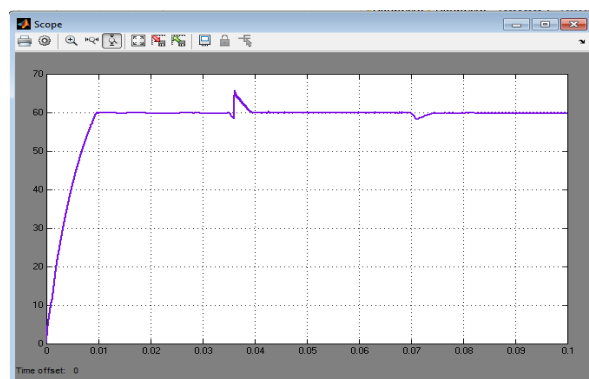

Fig. 8. Line regulation of POTLLC with neuro controller : Step change of supply voltage from 10-12.5V at 0.035 sec and 12.5- 10v at 0.07sec.

Fig.9 shows the output voltage of the converter with PI controller with a step change of $\pm 20\%$ of rated load at 0.035 sec and at 0.07 sec. It can be seen that the %peak overshoot is 7.5 and the settling time is 6msec for a step change of 10 -12 Ω and step change of 12 - 10 Ω , the %peak overshoot is 6.66 and the settling time is 7msec. Fig.10 shows the closed loop response of Triple-Lift Luo converter with fuzzy controller for sudden disturbances of 20% of rated load. The output voltage is regulated within 3msec and the peak overshoot is 5% for a step change of load from 10-12 Ω . The settling time is 6msec and the peak overshoot is 5.83% for a step change of load from 12-10 Ω .

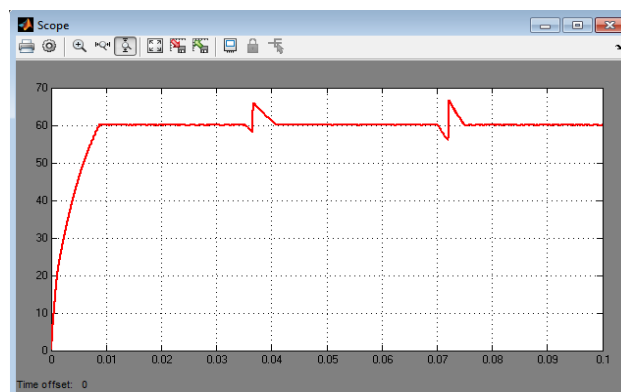

Fig.9. POTLLC under load regulation with PI control: Step change of resistance from 10-12 Ω at 0.035 sec and 12- 10 Ω at 0.07sec.

Fig.11 shows the output voltage of the Luo converter with neuro controller for a step change of $\pm 20\%$ of rated load at 0.035sec and at 0.07sec. It can be seen that the %peak overshoot is 4.1 and the settling time is 2msec for a step change of 10 -12 Ω . The %peak overshoot is 3.3 and settling time is 2msec for a step change of 12 - 10 Ω

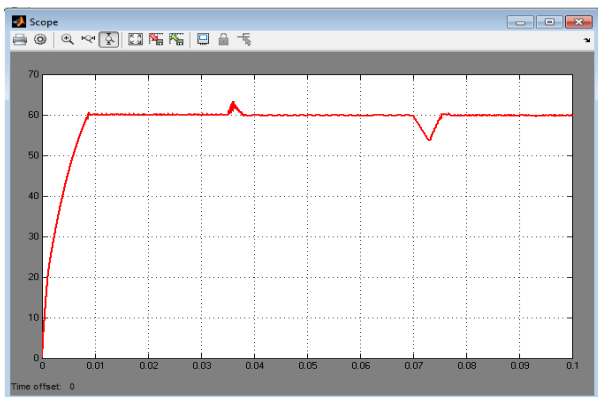

Fig.10. POTLLC under load regulation with Fuzzy controller : Step change of resistance from 10-12 Ω at 0.035 sec and 12-10 Ω at 0.07sec.

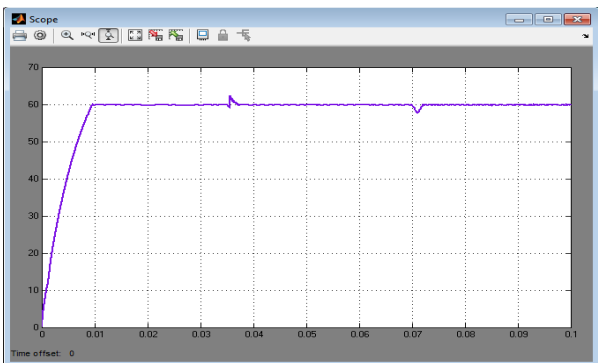

Fig.11. POTLLC under load regulation with neuro controller : Step change of resistance from 10-12 Ω at 0.035 sec and 12-10 Ω at 0.07sec.

Fig 12 and 13 show the line regulation and load regulation of POTLLC with PI , fuzzy and neuro controllers.

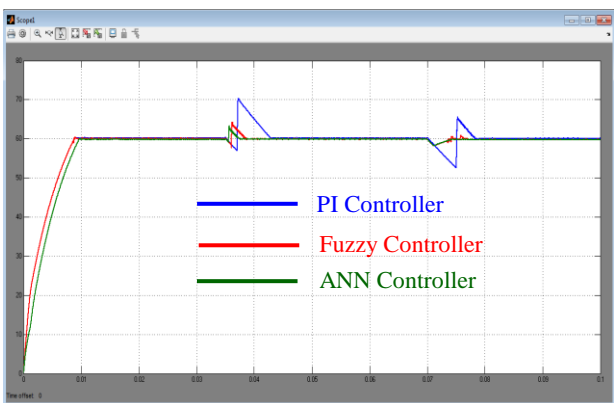

Fig. 12. Closed loop responses of POTLLC with various controllers under line variations.

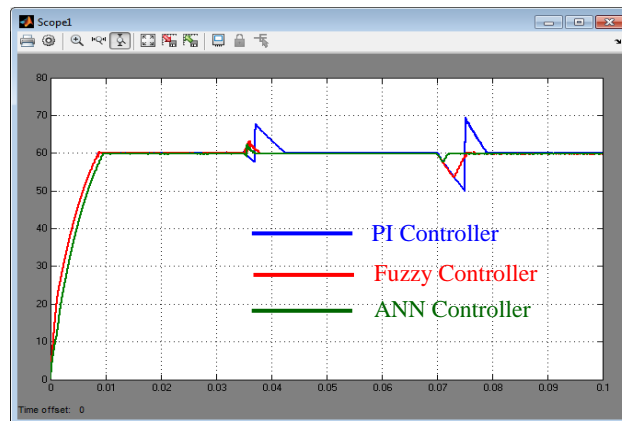

Fig. 13. Closed loop responses of POTLLC with various controllers under load variations.

The block diagram for the TMS320C242 DSP based implementation of closed loop control of a triple-lift Luo converter is shown in Fig.14 . The output voltage of the converter is scaled down to 0–5volts and read by the 10-bit ADC of DSP. The DSP executes 20 MIPS with 50 ns instruction cycle time. The conversion time of the on-chip ADC is 1 μ s. The DSP takes an average of 500 μ s to execute the fuzzy logic control algorithm, which involves sampling the output voltage, calculating the new duty cycle and updating the PWM output.

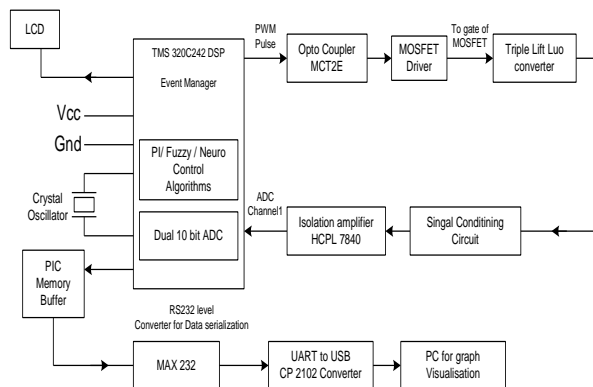

Fig .14. Block diagram DSP based implementation of closed loop control of a triple-lift Luo converter.

The switching device S_1 used is a N-channel MOSFET (enhancement type) IRF540N and S is a P-channel MOSFET IRF9630. In order to provide isolation between the Triple-Lift Luo converter circuit and the DSP, the isolation amplifier HCPL7840 is needed in the feedback path. The optocoupler MCT2E provides the isolation between the DSP and MOSFET of the Triple-Lift Luo converter. The PWM signal from the DSP is not capable of driving MOSFET. In order to strengthen the pulses, MOSFET driver IC IR2110 is used.

A snapshot of the experimental setup for a Luo converter is displayed in Fig.15. Fig.16 shows the output voltage for the Luo converter with PI controller for a step change of $\pm 25\%$ of rated supply voltage at 0.04sec and at 0.07sec. The experimental results show that the output voltage is regulated within a maximum of 12msec after line disturbances and the %peak overshoot is 10.05. The disturbance rejection of the fuzzy control is validated by the input voltage variation from 10V to 12.5V at $t = 0.04$ sec (Fig.17). The output voltage is

compensated within 5.2msec and the peak overshoot is 10%. For the step change in the supply voltage from 12.5V to 10 V at 0.07sec, the output voltage reaches the reference voltage within 5.5msec and peak overshoot is 8.2%. Fig.18, shows the experimental output voltage of the Luo converters with neuro controller under line disturbance. From the Fig.18, it can be seen that the input supply voltage was stepping-up from 10V to 12.5V (25% of rated supply voltage) at 0.04sec. The %peak overshoot and settling time are 8.16 and 4msec and stepping down from 12.5V to 10V (25% decrease of rated supply voltage) at 0.07sec. The %peak overshoot and settling time are 3.6 and 4.25 msec.

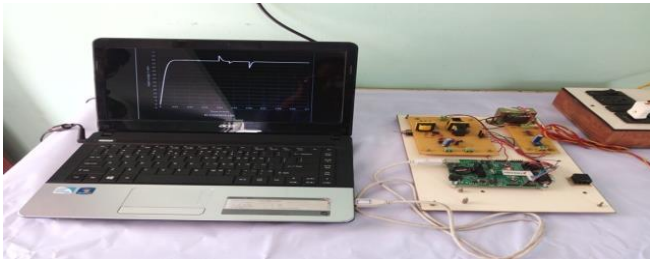

Fig.15. Hardware set up for Triple –Lift Luo converter.

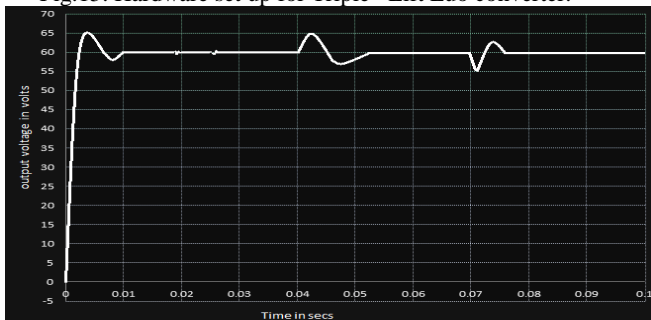

Fig. 16. Hardware output of Line regulation of POTLLC with PI control: Step change of supply voltage from 10-12.5V at 0.035sec and 12.5- 10v at 0.07sec.

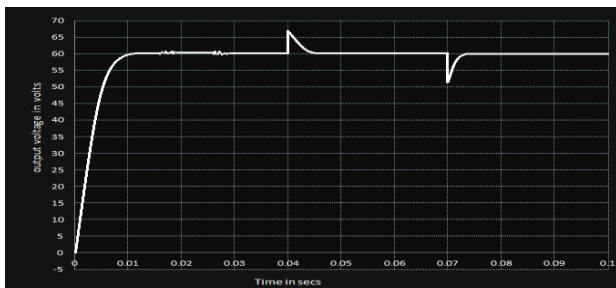

Fig. 17. Hardware output of Line regulation of POTLLC with fuzzy control: Step change of supply voltage from 10-12.5V at 0.035sec and 12.5- 10v at 0.07sec.

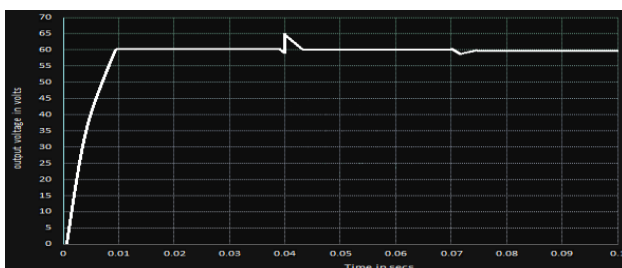

Fig.18. Hardware output of Line regulation of POTLLC with neuro control: Step change of supply voltage from 10-12.5V at 0.035sec and 12.5- 10v at 0.07sec.

Fig.19 shows the output voltage of the Luo converter with PI controller for a step change of $\pm 20\%$ of rated load at 0.04sec and at 0.07sec. It can be seen that the %peak overshoot is 8.16 and the settling time is 5.1msec for a step change of 10 -12 Ω and 8.50 and 4.65msec for a step change of 12 – 10 Ω . For the load variation from 10 Ω to 12 Ω at $t=0.04$ sec the output voltage of the converter with fuzzy controller is compensated within 4 msec and the %peak overshoot is 11.5 as shown in Fig.20. For the load variation of 12 Ω to 10 Ω at $t = 0.07$ sec, the output voltage is regulated within 3.92msec and the %peak overshoot of 9.12. Fig.21 shows the output voltage of the Luo converter with neuro controller for a step change of $\pm 20\%$ of rated load at 0.04sec and at 0.07sec. It can be seen that the %peak overshoot is 5.83 and the settling time is 3.05msec for a step change of 10 -12 Ω . The %peak overshoot is 5.33 and settling time is 2.89msec for a step change of 12 – 10 Ω

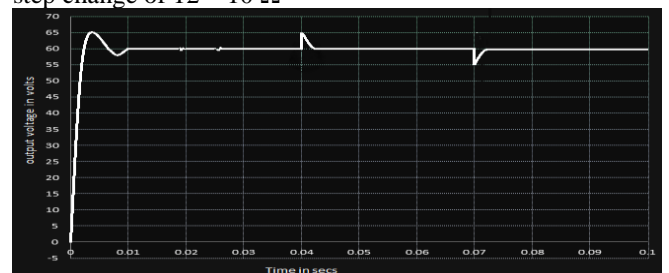

Fig. 19. Closed loop responses of positive output Triple-Lift Luo converter with PI control under sudden disturbances of $\pm 20\%$ of rated load.

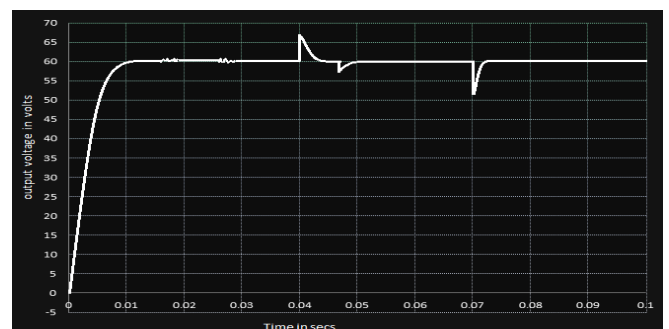

Fig. 20. Closed loop responses of positive output Triple-Lift Luo converter with fuzzy control under sudden disturbances of $\pm 20\%$ of rated load.

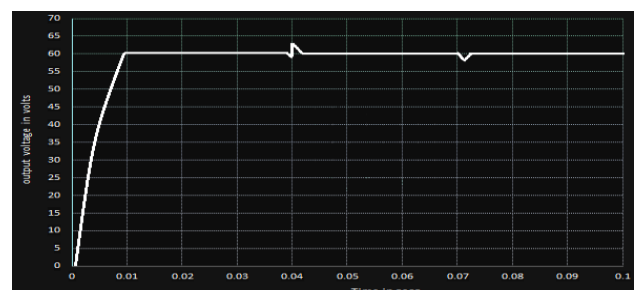

Fig. 21. Closed loop responses of positive output Triple-Lift Luo converter with neuro control under sudden disturbances of $\pm 20\%$ of rated load.

Table III Performance comparison of simulation and experimental results for positive output Triple – Lift Luo converter

	Controller	Start up Transient					Supply Disturbances				Load Disturbances			
		Delay time (ms)	Rise time (ms)	Peak overshoot (%)	Peak time (ms)	Settling time (ms)	Supply increase (25%)		Supply decrease (25%)		Load increase (20%)		Load decrease (25%)	
							Peak overshoot (%)	Settling time (ms)	Peak overshoot (%)	Settling time (ms)	Peak overshoot (%)	Settling time (ms)	Peak overshoot (%)	Settling time (ms)
Simulation	PI	2	7	0	-	8	10	6	8.33	8	7.5	6	6.66	7
	Fuzzy	2	6	0	-	7	8.33	3	5.83	7	5	3	5.83	6
	Neuro	2	7	0	-	7	8.03	3	3.33	4	4.1	2	3.3	2
Hardware	PI	3	5	9.16	5.5	10	10.05	12	8.50	8.75	8.16	5.1	8.50	4.65
	Fuzzy	3	5	0	-	10	10	5.2	8.2	5.5	11.5	4	9.12	3.92
	Neuro	3	8	0	-	9	8.16	4	3.6	4.25	5.83	3.05	5.33	2.89

7. Conclusions

From table III, Positive output Triple-Lift Luo converters with PI, FLC and ANN controllers are analyzed. The experimental results confirm that intelligent controllers rejects both line and load disturbances. Also the results proved that neuro controller gives the smooth response for both line and load disturbances according to the desired voltage .Using the above controllers, stable and zero ripple output voltage of the Triple-Lift Luo converter is obtained.

References

- [1] Luo, F.L. , “Luo converters: new DC-DC step-up converters,”. Proceedings of the IEE international conference ISIC-97, Singapore, pp. 227-230,1997.
- [2] Luo, F.L., “Luo converters - voltage lift technique (negative output),” Proceedings of the second World Energy System international conference WES’98, Toronto, Canada, pp. 253-260, 19-22 May 1998.
- [3] Luo, F.L., “Luo converters: new DC-DC step-up converters,” Proceedings of the IEE international conference ISIC-97, Singapore, pp. 227-230, 1997.
- [4] Luo, F.L., “Luo converters - voltage lift technique (negative output),” Proceedings of the second World controller and Fuzzy Logic controller on DC/DC Buck Boost converter, IEEE symposium on Industrial Electronics and Applications (ISIEA), pp 149-154, Langkawi, Sep. 2011.
- [5] N.F. Nik Ismail, N. Hasim and R. Baharom, “A Comparative study of Propotional Integral Derivative,” IEEE Proceedings of Power Electronics and Drive systems, pp. 1228-1233. Dec 2005.
- [6] Alfred Baghramian and Hasan Ghorbani Eshyani, “Control of DC Motor’s Speed Using Fuzzy Logic Controller and Luo Converter,” Proceedings of EIE’s 2nd Intl’ Conf. on Comp., Energy, Net., Robotics and Telecommunication, 2012, pp. 24-28.
- [7] M.Rabbani, H.M.M. Maruf, T. Ahmed, M.A. Kabir and U. Mahbub, “Fuzzy Logic Driven Adaptive PID Controller for PWM Based Buck Converter,” International Conference on Informatics, Electronics & Vision (ICIEV), pp. 958-962, Dhaka, May 2012.
- [8] F.L, Luo, “Positive output Luo-converter lift technique,” IEE-EPA/proceedings, 146(4), pp.415-432, July 1999
- [9] B.Achiammal and R.Kayalvizhi “Hardware implementation of optimized PI controller for LUO converter,” International Journal of Applied Engineering Research (IJAER), Volume 10, no 14, pp.34899-34905, 2015.
- [10] Mehrdad Ahmadi Kamarposhti , Toraj Tayebbifar, Mohammad Shaker, Pegah Nouri” The Control of Buck Boost DC-DC Converters for DC Motor Drives on variable DC Voltage by Using Neural Network”, Life Science Journal,pp 236-240,volume 10,no 5,2013.
- [11] Abdul Sattar Larik, Mohammad Rafiq Abro, Mohammad Aslam Uqaili. “Performance Analysis and Intelligent Power Controller Design of Soft Switched Half Bridge dc/dc Converter using Neural

- Networks,” *International Journal of Computer Applications*,21-27,volume 46,no 15,May 2012.
- [12] José M. Quero, Juan M. Carrasco and Leopoldo G. Franquelo, “Implementation of a Neural Controller for the Series Resonant Converter,” *IEEE Transactions On Industrial Electronics*, pp629-639, Vol. 49, No. 3, June 2002.
- [13] Ramanujam Kayalvizhi, Sirukarumbur Pandurangan Natarajan and Padmaloshani Palanisamy , “Development of a Neuro Controller for a Negative Output Elementary Luo Converter,” *Journal of Power Electronics*, pp. 140-145,Vol.7,No.2,2007.
- [14] Dhanasekar.N and Kayalvizhi R. “Soft Computing Technique for the control of Triple-Lift Luo Converter,” *International Journal of Engineering Research and Application (IJERA)*, Vol.7(3), Mar., pp. 35-38
- [15] Dhanasekar N and Kayalvizhi, “neural network controller for Triple-Lift Luo Converter,” *International Journal of Advanced Research in Electrical, Electronics and Instrumentation Engineering*,Vol.6(4),Apr., pp.2664-2670.