

# POWER QUALITY ENHANCEMENT BETWEEN TWO ADJACENT FEEDERS USING WHALE OPTIMIZED IDVR

M.Sarojini Devi<sup>1</sup>, V.Suresh Kumar<sup>2</sup>

<sup>1</sup>Associate Professor, Department of Electrical and Electronics Engineering, Mohamed Sathak Engineering College, Kilakarai, Tamil Nadu, India

<sup>2</sup>Associate Professor, Department of Electrical and Electronics Engineering, Thiagarajar College of Engineering, Madurai, Tamil Nadu, India

Sarojinitce1975@gmail.com, vskeee@gmail.com

## Abstract

This paper proposes a novel control strategy based interline dynamic voltage restorer to improve the power quality between the two adjacent feeders in a distribution system. The interline dynamic voltage restorer is an interconnected form of multi dynamic voltage restorer with a common share of DC link. The artificial intelligence based control strategy is proposed here to achieve the faster rectification of the power quality issues such as voltage sag, voltage swell and harmonics. The whale optimization algorithm is proposed as the control strategy to accelerate the performance of the compensating unit towards the issues rectification. The architecture, control strategy and the performance are discussed in the paper. The effectiveness of the proposed whale optimized interline dynamic voltage restorer system is verified through the comparative analysis with the conventional optimization algorithms such as Ant Lion Optimizer and particle Swarm Optimization. The Fast Fourier transformation analysis for the harmonics rectification was discussed in the resultant part of the paper. The unabridged working of the proposed technique had implemented in Matlab/Simulink and verified.

**Keywords:** Power quality enhancement, Adjacent feeders, Interline dynamic voltage restorer, Whale optimization algorithm, Harmonic.

## 1. Introduction

The modern power system are complex networks, in which load centers and generating stations are interconnected through the distribution and power transmission networks. The quality and reliability of power supply is the main concern of consumers at various load centers, in which the devices are located [1]. In developed region, the power generation is reliable, but the quality of power supply is not much reliable when compared with the power generation. The power distribution system provides the uninterrupted power flow of sinusoidal voltage waveform with corresponding frequency and magnitude with their patrons. The distribution system

have number of nonlinear loads, thus it can degrade the quality of power supply [2-5].

In three phase network, the working of DVR is based on the serial injection of alternating current to the transmission line. The quality of the power can be improved through the little alteration appears in the phase shift, magnitude of voltage and wave shape. The real and reactive power can be introduced into the feeders which embraces the voltage sag compensation. The voltage source inverter is offered in the dynamic voltage restorer, given in Fig. 1 and it can engender the reactive power [6-8].

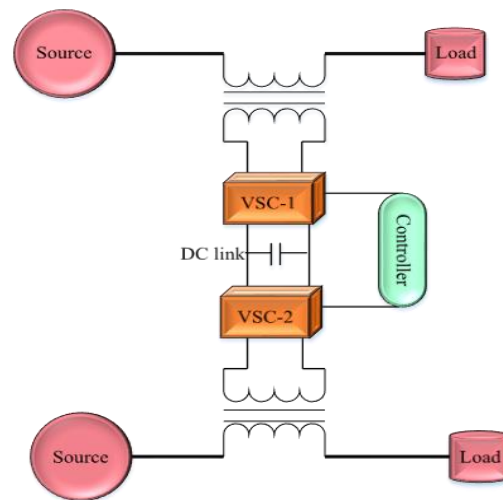

Fig. 1. Interline dynamic voltage restorer

The controller can diminish the steady state error and transient response. The DVR system can acts on virtual impedance. The system is used to protect the consumers from the disturbances and flowing of error current into the DVR. Then the system can restrict the fault current to protect the feeder through the default connection of feeder [9-11]. The DVR is the series coupled device, in which the sag swell is removed. The working principle of DVR is the injection of voltage with the required magnitude, frequency and phase angle in order to maintain the load voltage and amplitude [12].

The distribution network can be reconfigured by opening or closing the corresponding switch, when the power presented in the man station is rerouted. The radial arrangement of the network is maintained by the open switch. Thus the loss is reduced in the network [13-15]. The IDVR can insert the power into the faulty feeder system, in order to generate the load voltages. This can be obtained by the optimization angle and of VA rating and. The optimization progress is carried out by the algorithm [16-17].

The voltage deviation is developed in the feeder and it can be rectified by the component of IDVR. This can be decomposed into several DVR and it is coupled to the distribution feeders which can share the common energy among the feeders. The single phase IDVR is operated under the pulse width modulation. In a consumer side the power quality was the major problem and in the utility side the impacts of voltage swell, sag and harmonics had create the problem to the user equipment. This can be overcome through the construction of IDVR and it can preserve the voltage between the feeders. The PWM signals were generated due to the presence of proportional integral controller [18-20]. The energy is distributed through the feeders and it is affected by transmission line loss. The loss can be avoided due to the construction of interline dynamic voltage restorer. The proposed system can beat the existing system's impacts. The major contribution of the proposed methodology is as follows.

- ✓ The work is proposed for the mitigation of power quality issues using the interline dynamic voltage restorer with a novel control strategy.
- ✓ Even though the artificial intelligence based control methods applied for DVR, the proposed work is better in terms of error minimization and convergence.
- ✓ The power quality enhancement is achieved in between two adjacent feeders with IDVR system.

The paper is further arranged as follows: the section 2 analyses some recent literatures; section 3 illustrates the proposed methodology with constraints and Interline Dynamic Voltage Restorer; section 4 depicts the control strategy; section 5 is the result and discussion and section 6 concludes the paper.

## 2. Related Work

The active power was interchanged between the dynamic voltage restorers and interline dynamic voltage restorer. The selection of corresponding voltages in DVR is the major thing of IDVR. The optimization problem occurs in previous works which corresponds to the apparent power. The

criterion was used to choose the rated voltages. The feeders were connected with the load by varying that can degrade the active power interchanging between the voltage and DVR, when the loads were assumed to be constant or otherwise mentioned by its rated value. So in most of the works the load variation was the major problem and it had been developed by Moradlou et al [21]. The time interval of this problem is long, so genetic algorithm was considered to rectify it. By making this strategy, the cost of DVR was reduced.

In practical system, the distribution feeder reconfiguration with distributed generators can use the multi objective evolutionary algorithm. The major issue in the power system was the transient stability of distribution generation and it had been established by Mahboubi-Moghaddam et al [22]. The transient stability can be removed when the penetration becomes low. The usage of gravitational search algorithm in order to reduce the loss, cost and improve the transient stability index. The effectiveness of the system can be tested in the IEEE33 bus system.

In existing, the distribution generation can use the single phase equivalent and the three phase system was balanced and it had been developed by Ding F et al [23]. The factors such as, three phase line topology, single phase loads and non-symmetrical conductor spacing, due to this the distribution feeders were unbalanced. The nonlinear programming and the sensitive analysis were used to identify the size of distribution generation and the location. The distribution generation had reconfigured based on the load variation with respect to the time, loss reduction, and operating cost. Thus the simulation results shows that the efficient and effectiveness of the proposed approach.

The power quality problems were appeared due to the nonstandard current, frequency and voltage and it can creates the failure of the user equipment. The voltage swell and sag was the major impacts. The distribution network and load were suffered from the service interruption and outages which leads to the financial loss. The custom power devices were used to get the improved power quality. This was implemented in MATLAB and it had been presented by et al [24]. The voltage sag, swell can be beaten by the device. The displacement factor can be effectively achieved through the interchange of active and reactive power.

The series compensation topology was presented by Li Pet et al [25]. The topology was used here to improve the voltage and the ellipse parameter was obtained by dynamic voltage restorer. The

magnitude of voltage was inserted in series to the distribution line. The mathematical modelling was derived by the iterative process. The elliptical parameters of major, inclination and minor axis were used to the algorithm development. The voltage source converters were connected to the common dc side. Thus the resultant development can yield high accuracy.

### 3. Proposed Methodology

The schematic diagram of proposed methodology is given in Fig. 2. The term power quality is defined like the distribution of unwavering and reliable power to the end customer. Due to many physical and nonphysical reasons the power quality has been affected. Here the attainment of power quality from the two adjacent feeders with power quality interruption is discussed. The enhancement power quality is derived from interline dynamic voltage restorer. The IDVR had placed in between the two adjacent feeders in order to diminish the issues such as sag, swell and harmonics.

#### 3.1. Constraints

The constraints considered in the work are described below,

*Voltage sag:* The resultant of a huge current flow in the system or voltage across the system is denoted as the voltage sag or dip. The foremost intention to the dip is the short circuit in the system. The dip may be described as follows.

$$v = \tau \frac{\text{apparent power}}{\text{short circuit apparent power}} \quad (1)$$

Where,  $v$  denotes the variation in voltage and  $\tau$  is the voltage reduction factor.

*Voltage swell:* The short duration voltage variation defined as the sudden rise of voltage when the load is switching off. The replacement of load from one source of power to the different source may induce the swell effect. It can be mathematically formulated as,

$$v = \max_{\text{apparent power}} \frac{(z_a \cos \phi - z_b \sin \phi)}{V^2} \quad (2)$$

Where  $z_a$  and  $z_b$  is the impedances of feeder,  $\phi$  is the difference in phase and  $V^2$  is the normal feeder voltage.

*Harmonics:* The distortion of current and voltage from the nominal level which oscillate the supply voltage.

$$V_{\text{harmonics}} = \sqrt{\sum_{N=2}^{\infty} \frac{V_N^2}{V_1^2}} \times 100 \quad (3)$$

#### 3.2. Interline Dynamic Voltage Restorer

The number of dynamic voltage restorers are interconnected with a common sharing of DC link for storage is commonly known as interline dynamic voltage restorer. The utilization of IDVR is extended to the fortification of sensitive loads. The common sharing of DC link resulted in the capacity reduction and also the cost of compensation devices. The working of IDVR is depends on the sag mitigation and power control modes. The dynamic and fast response of the IDVR system is depends upon the controller.

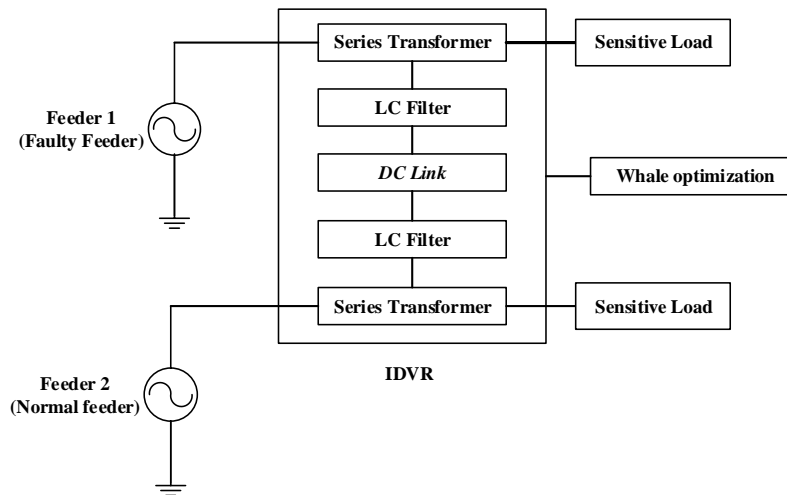

Fig. 2. Block diagram of the proposed work

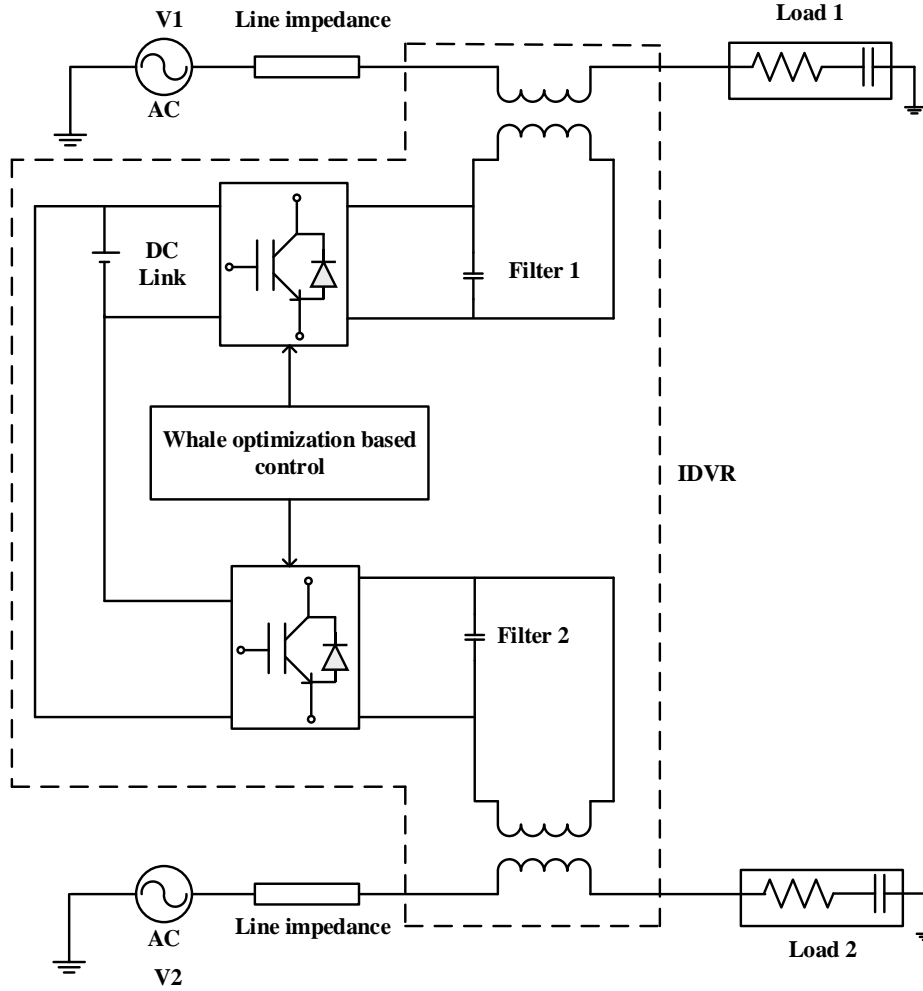

Fig. 3. IDVR between adjacent feeders

### 3.2.1. Analysis of IDVR between adjacent feeders

The Fig. 3 shows the two interconnected DVR are separately connected with the two adjacent feeders. If the DVR which is connected with the feeder 1 is working in the sag compensation mode then the other device connected with second feeder will utilize the power control mode and vice versa. The adjacent feeders are originating from the different grid stations then voltage interruptions on one feeder having lesser impact on the operation of other feeder. Consider that the DVR connected in the feeder 1 acted in the voltage compensation mode and opponent in power control mode. Since the feeder two is not associated with sag there load voltage is merely equal to the supply voltage. For replenishing the power by the second DVR there should be some exchange of power between feeder 1 and feeder 2. It can be defined as below.

$$P_E^R = S_2 [\cos(\phi_2 - \alpha) - \cos(\phi_2)] \quad (4)$$

In (3)  $S_2$  is the load apparent power of feeder 2,  $\phi_2$  is the power factor angle and  $\alpha$  is the phase angle of load voltage.

The power factor angle and phase angle of load voltage are equal in a certain operation condition of feeder where the real power exchange is in maximum level. The voltage of supply is in phase to the current flowing into the feeder 2 and the maximum real power exchange is described in (4).

$$P_E^R \text{ max} = S_2 [1 - \cos(\phi_2)] \quad (5)$$

By utilizing the real power introduced by the dynamic voltage restorer connected in the first feeder and by the system losses is expressed in (6).

$$P_E^R = P_1 + P_{sl} \quad (6)$$

Where,  $P_1$  is the power injected by the first DVR and  $P_{sl}$  is the system losses. The real power taken by DVR in the feeder-1 is causing impacts on the phase angle of load voltage.

### 3.2.2. Voltage restoration method

The injection of real power for compensation from the dynamic voltage restorer depends on the method of voltage restoration. The methods are,

- ✓ Pre-sag supply voltage method
- ✓ In-phase injection method
- ✓ Energy-saving injection

For the proposed work the pre-sag compensation is utilized. The pre-sag injection method takes the difference of voltage at the sag condition and pre-sag condition and injects it. By doing this the load voltage can be obtained the pre-sag voltage level. The real power injected in the pre-sag compensation method is depicted in the following expression.

$$P_1 = S_1 \left[ \cos(\phi_1) - \frac{\sqrt{x^2 + y^2}}{3} \cos(\phi_1 + \omega) \right] \quad (7)$$

The above equation holds  $x = \sum_{i=1}^3 A_i \cos(\pi_i)$

and  $y = \sum_{i=1}^3 A_i \sin(\pi_i)$ . Then  $\omega$  is identified by utilizing the expression  $\tan^{-1} \left[ \frac{Y}{X} \right]$ .

The phase angle of the load voltage can be rewritten as below by assuming a voltage sag in a balanced level with a sag factor  $\ell$ . In Eq. (8),  $G$  is the voltage sag factor and  $\nu$  represents the phase angle jump.

The transfer of maximum real power the voltage sag factor should be as below (Eq. 9). The

$$\alpha = \phi_2 - \cos^{-1} \times \left[ \frac{S_1 [\cos(\phi_1) - G * \cos(\nu + \phi_1) + P_{sl}]}{S_2} + \cos(\phi_2) \right] \quad (8)$$

$$\nu = \left[ \frac{S_1 \cos(\phi_1) + P_{sl} - S_2(1 - \cos(\phi_2)) + S_3(1 - \cos(\phi_3)) + \dots \dots S_n(1 - \cos(\phi_n))}{S_1 \cos(\phi_1 + \nu)} \right] \quad (9)$$

equation (9) utilized for the connection of n number of dynamic voltage restorers in between the feeders. Not only the load power factor but also the phase angle jump had the influence on the sag factor of the compensation devices.

## 4. Whale Optimization Algorithm

The compensation voltage from the interline DVR system inherently depending on the control signal modulated by the pulse width modulator. By utilizing the difference between the required reference voltage and supply voltage as the objective function the compensation voltage had obtained by the whale optimization algorithm. The procedure for the utilized algorithm is deeply expressed in the following lines.

The natural hunting behavior of the humpback whales was the stimulation for the development of this algorithm [26]. The bubble net hunting strategy had utilized by these kind of whale to chase the preys such as small fish herds and krill. The circle or 9 shaped ring is utilized to create the bubbles. This procedure was modelled to develop the optimization algorithm. The modelling includes two phases such as exploration and exploitation.

### 4.1. Encircling the prey

The search agent is initialized and its solution is assumed as the best in this phase. The locations of the other agents were updating towards the best agent to reach the prey. The best agent is described as follows.

$$B = |A \cdot x^*(t) - x(t)| \quad (10)$$

$$x(t+1) = x^*(t) - Y \cdot B \quad (11)$$

Where,  $t$  is the indication of current iteration,  $A$  and  $Y$  are the coefficient vectors,  $x^*$  is the best solution's location.

The vectors  $A$  and  $Y$  are evaluated as,

$$Y = 2s \cdot R - s \quad (12)$$

$$A = 2 \cdot s \quad (13)$$

In the above equation (Eq. 12 and 13), the value of  $s$  is linearly decreased from 2 to 0 when the number of iterations are increasing and  $R$  is having the values between 0 and 1 is a random vector.

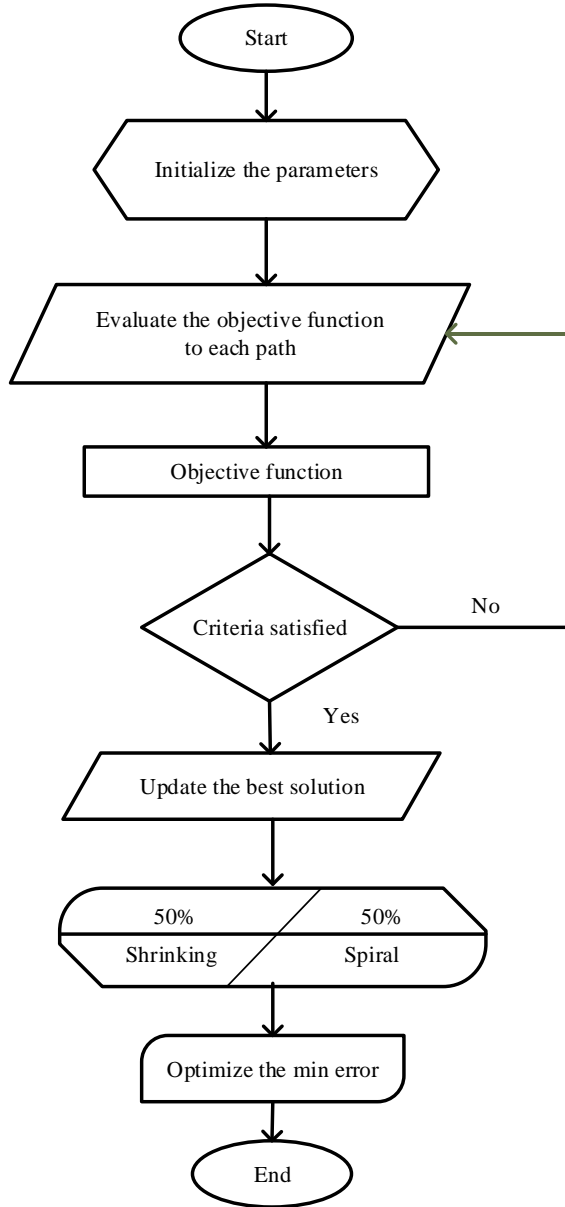

Fig. 4. Flow chart for whale optimization algorithm

#### 4.2. Bubble net creation (exploitation phase)

The two approaches in the bubble net creation phase are shrinking encircling and spiral updating techniques.

**Shrinking encircling technique:** The random vector is reduced from 2 to 0 over the optimization of best value the coefficient vector  $Y$  is placed in  $[-1, 1]$ . During the placement the new location of search

agents are identified and from which the best location is selected.

**Spiral updating technique:** The distance between the position of whale and prey is evaluated using a spiral equation.

$$x(t+1) = B_1 e^{cr} \cos(2\Pi r) + x^*(t) \quad (14)$$

$$B_1 = |x^*(t) - x(t)| \quad (15)$$

The distance between the humpback and prey is estimated through the equation (15). In that equation  $c$  is a constant and  $r$  is the random number valued between -1 and 1. There is a possibility 50% for utilization of the two hunting techniques. Therefore the position of search agent is updating through the following expression.

$$x(t+1) = \begin{cases} x^*(t) - Y.B & \text{if } prob < 0.5 \\ B_1 e^{cr} \cos(2\Pi r) + x^*(t) & \text{if } prob \geq 0.5 \end{cases} \quad (16)$$

Where,  $prob$  is a random number between 0 and 1.

#### 4.3. Search for prey (exploration phase)

The whales are randomly search for prey based on that the position is moving towards the best search agent. The expression in a mathematical manner is described as,

$$B = |A.x_{rand} - x| \quad (17)$$

$$x(t+1) = x_{rand} - Y.B \quad (18)$$

Where  $x_{rand}$  is a random whale's random location.

#### 4.4. Objective function evaluation

The minimization error value between the reference and supply voltage is the main objective. The evaluated objective is matched to the control signal. The objective is represented in (19).

$$objective = V_{supply} - V_{reference} \quad (19)$$

The error minimized control signal is evaluated from the objective function. This output is given to the pulse width modulator to convert it into the analog signal.

In general the control strategy of dynamic voltage restorer belongs to open loop and closed loop methodologies. Instead of those the proposed work utilizes the optimization based control strategy. The output of the optimization algorithm is converted into control signal via a PWM inverter circuit. The power quality disturbances especially voltage sag and voltage swell are not higher than that of 50%. The



operation of the PWM inverter can be described by the frequency and the duty cycle.

### 5. Result and Discussion

The power quality enhancement in two adjacent feeders is considered as the major objective of this research work. The compensation through the interline dynamic voltage restorer with the control of whale optimization algorithm for the faster response of the IDVR is described. The work is implemented using Matlab/Simulink installed in the system having the configuration of windows 10 ultimate with 4GB RAM and 64 bit operating system. The Table 1 represented the initial parameter settings of the proposed control strategy.

Table 1. Parameter settings

Parameter	Value
Search Agents	30
Maximum iteration	500
Constant	0.5
Random vector	2 to 0

#### 5.1. Existing methodology based on Ant lion optimization algorithm

Figure 5 provides the Simulink model of the existing system based on ALO and the figure 6 represents the power quality issues mitigation by ALO algorithm.

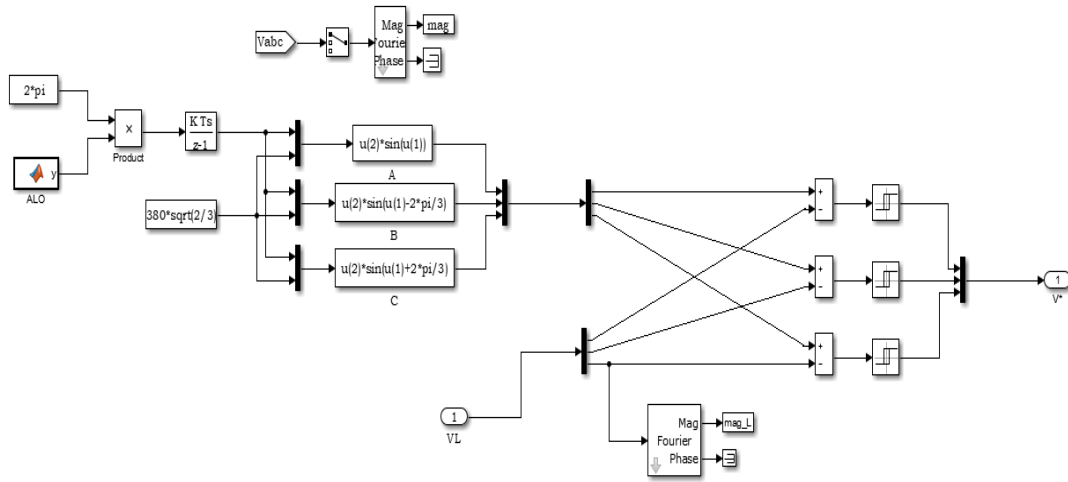

Fig. 5. Simulink model of existing system (ALO)

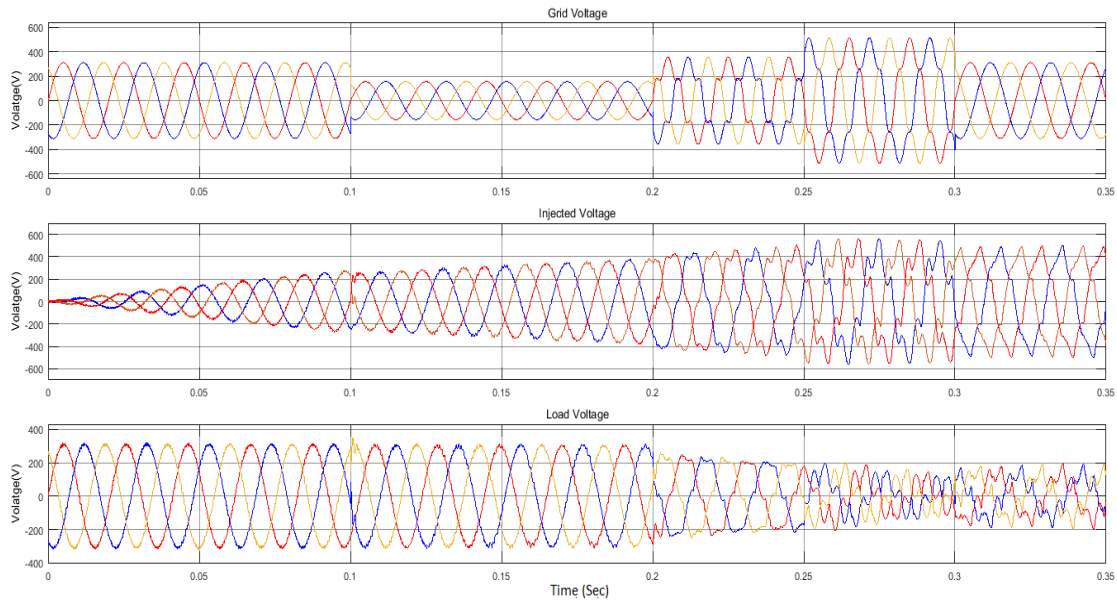

Fig. 6. Compensation by ALO

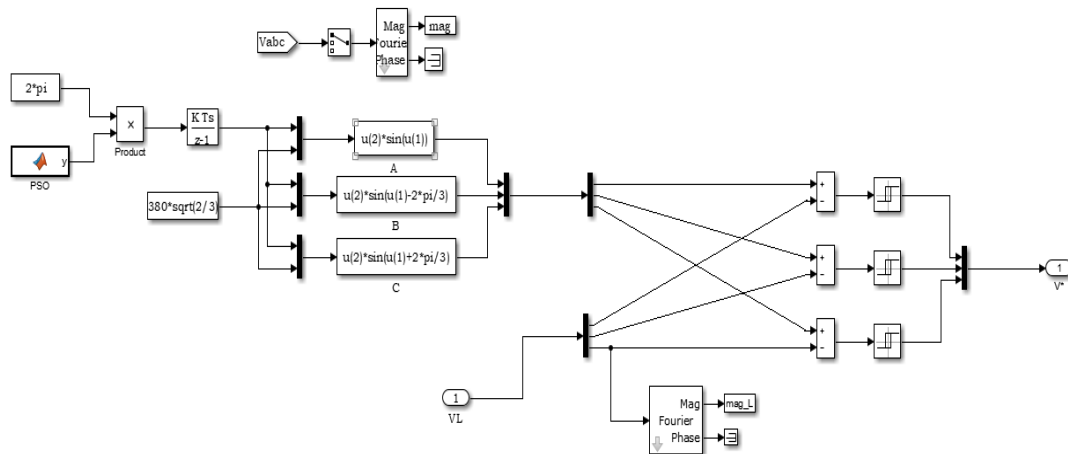

Fig. 7. Simulink model of existing system (PSO)

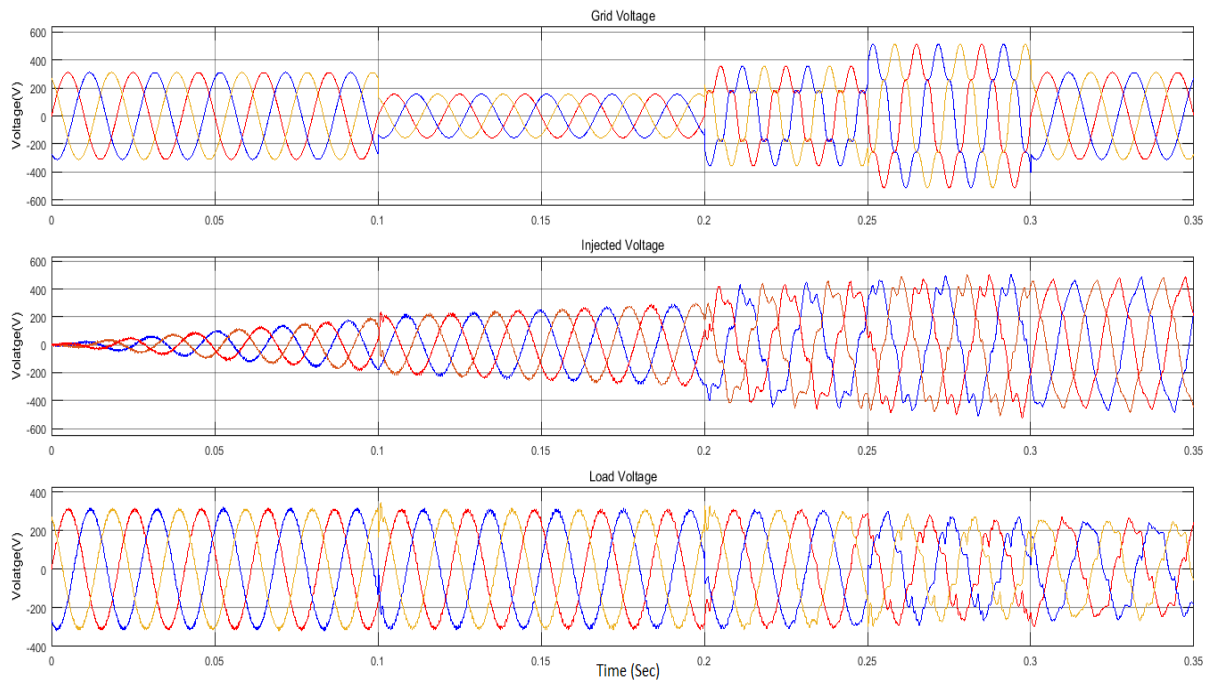

Fig. 8. Compensation by PSO

## 5.2. Existing methodology based on Particle swarm optimization

Figure 7 provides the Simulink model of the existing system (PSO) and the figure 8 represents the power quality issues mitigation by PSO algorithm. It has shown enhanced results than the ALO based control approach.

## 5.3. Analysis based on proposed methodology

Figure 9 provides the Simulink model of the proposed system. The interline dynamic voltage

restorer system is connected between two adjacent feeders and its operation is controlled via the whale optimization algorithm.

Figure 10 represents the grid voltage without any fault. The figure 11 represented the grid voltage with sag issue in the duration 0.1 to 0.2 sec. The injected voltage is rectified the problem of sag and finally the load voltage without any fault is shown in the above figure.



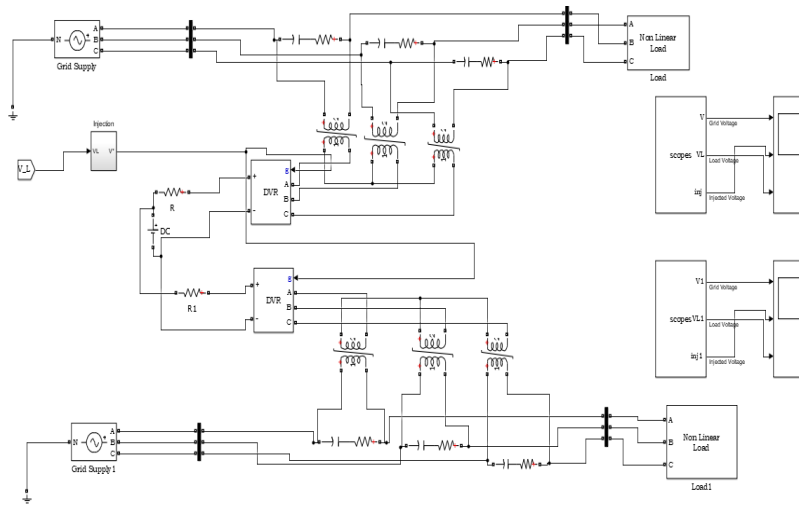

Fig. 9. Simulink model of proposed system

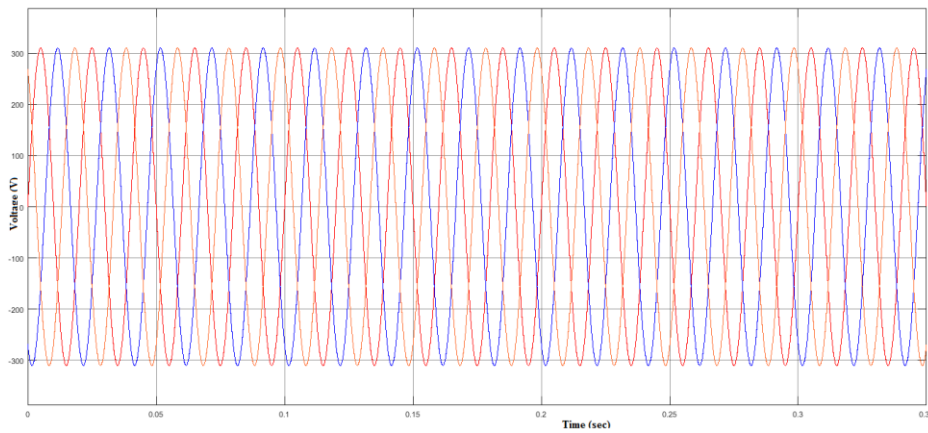

Fig. 10. Normal grid voltage (Without fault)

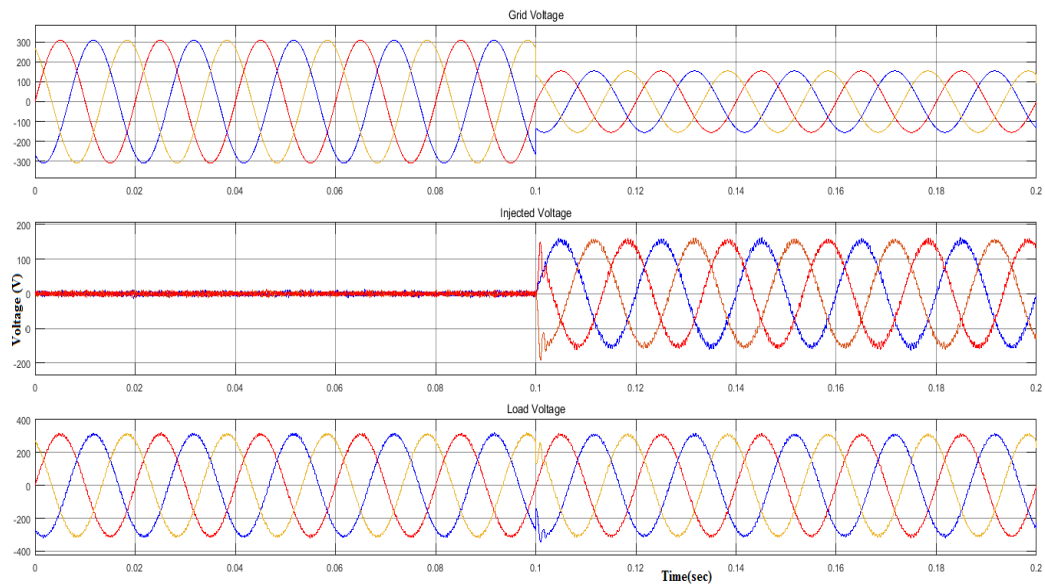

Fig. 11. Grid voltage with sag and compensation

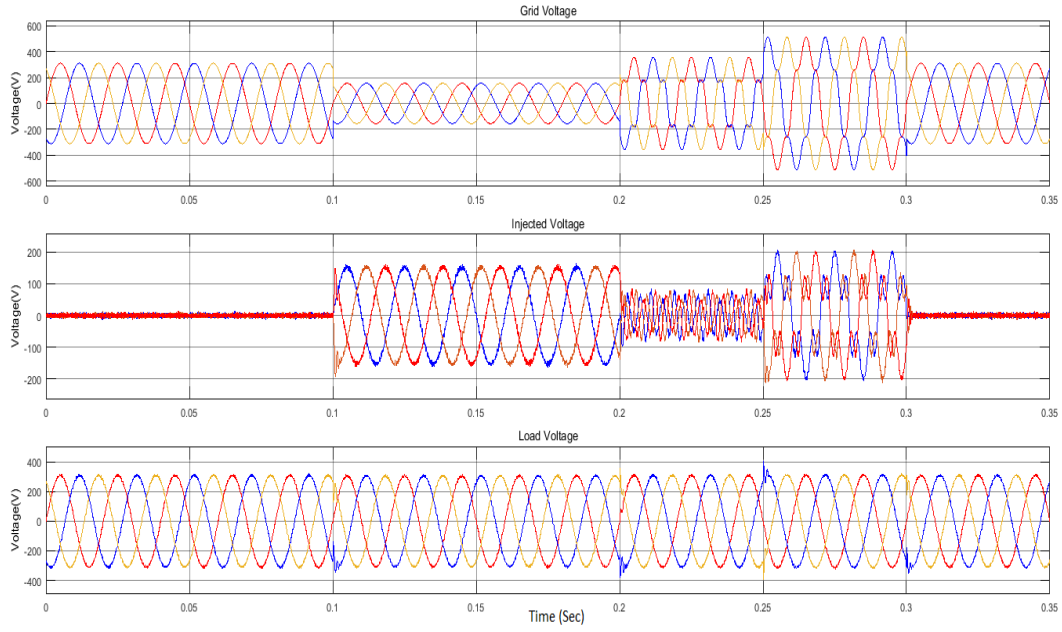

Fig. 12. Grid voltage with sag and swell with compensation

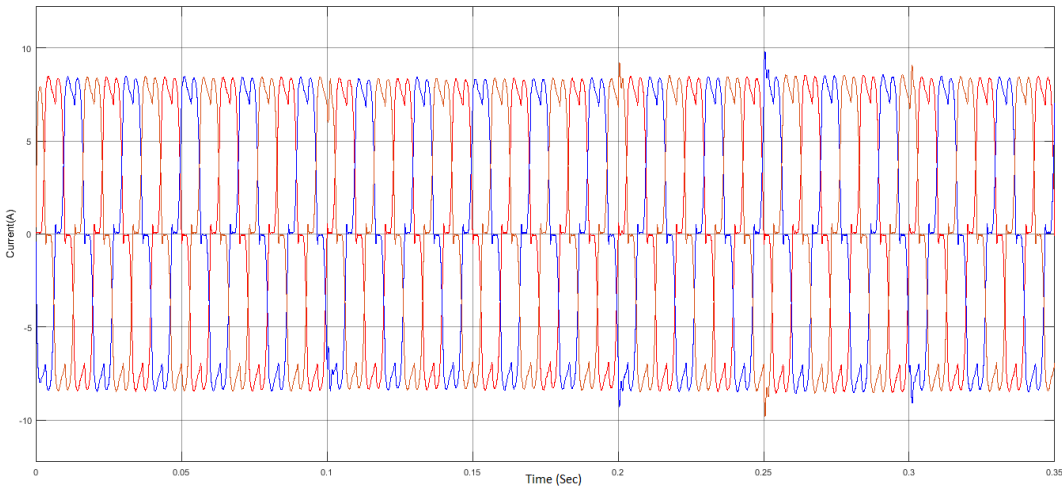
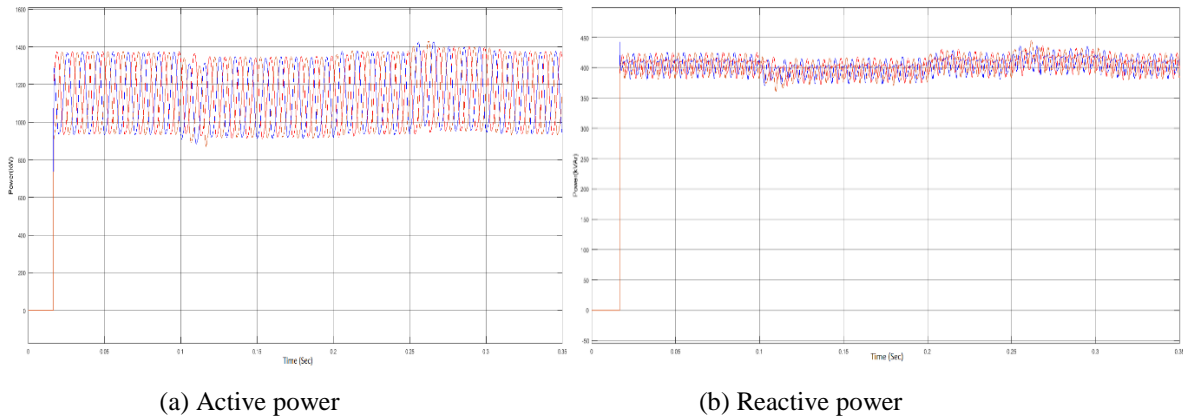

Fig. 13. Output current



(a) Active power

(b) Reactive power

Fig. 14. Output power

The figures 12, 13 and 14 show the results of whale optimized controlled IDVR system for power quality improvement. While at the voltage unbalances the DVR connected to the corresponding feeder injects the compensation voltage. In fig 12 the grid voltage was shown with voltage sag in the time period between 0.1 to 0.2 seconds. Likewise the swell occurrence is indicated in 0.25 to 0.3 seconds. During that time period the DVR injects compensating voltage and the issues are rectified.

The below represented figures 11 and 12 indicates the compensation by the existing algorithms Ant Lion Optimizer (ALO) and particle swarm optimization algorithm (PSO). When comparing these algorithms with the proposed control based compensation lesser performance is verified. The Table 2 is the depiction of the three algorithm based compensation.

#### 5.4. FFT analysis for harmonics

The FFT analysis of harmonica is shown in figure 13 and the performance of the proposed system is compared with existing algorithms. The harmonics value before applying any of the compensation techniques is 89.93% and it was reduced to a value of 2.38% by proposed and 20.67%, 14.23% by ALO and PSO respectively.

**Table 2:** Mitigation of harmonics

Harmonics	Before Compensation	After Compensation
Whale optimization	89.93%	2.38%
ALO		20.67%
PSO		14.23%

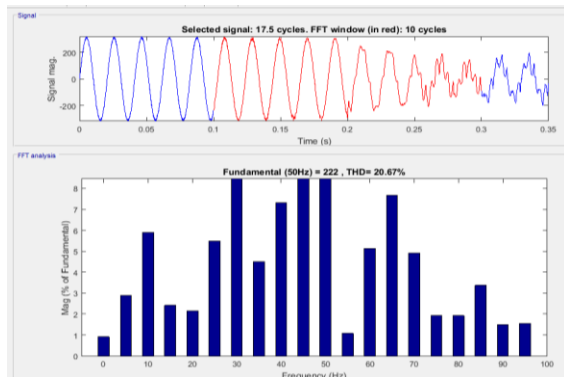

(a) ALO

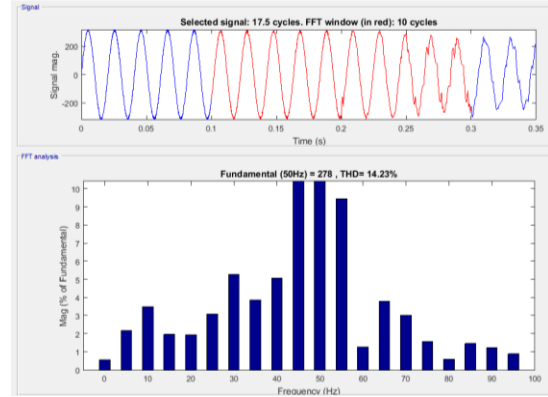

(b) PSO

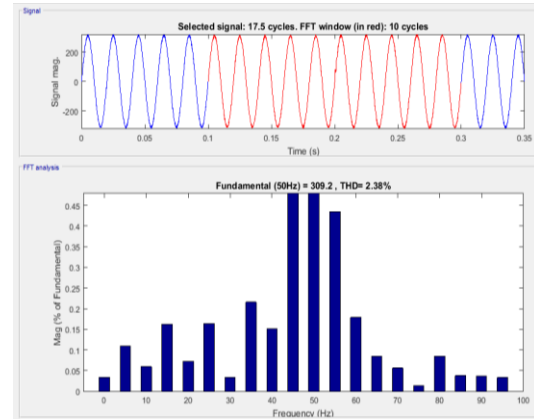

(c) Whale optimization algorithm

**Fig 13:** FFT analysis

#### 6. Conclusion

The work demonstrates the operation and control of interline dynamic voltage restorer in the distribution system. The IDVR system is connected in between to the two adjacent feeder of the distribution system. The efficient working of IDVR was analysed when the feeder of the corresponding DVR is affected with a power quality issue. The whale optimization algorithm utilizing the error minimization in the voltage as the control strategy improves the dynamic response of the dynamic voltage restorer. From the results it was proved that the proposed whale optimized IDVR system regulated the voltage at the terminals of the feeders and protected the sensitive load from the disturbances. The comparison is given via the ALO and PSO. The satisfactory performance of the proposed system was obtained in the comparative analysis.

## Reference

1. Shahabadini M, and Iman-Eini H, "Improving the performance of a cascaded H-bridge-based interline dynamic voltage restorer," IEEE Transactions on Power Delivery, vol.31, no.3, pp.1160-1167, 2016.
2. Sadigh AK, and Smedley KM, "Fast and precise voltage sag detection method for dynamic voltage restorer (DVR) application," Electric Power Systems Research, vol.130, no. 1, pp.192-207, 2016.
3. Roldán-Pérez J, García-Cerrada A, Ochoa-Giménez M, and Zamora-Macho JL, "On the Power Flow Limits and Control in Series-Connected Custom Power Devices," IEEE Transactions on Power Electronics, vol.31, no.10, pp.7328-7338, 2016.
4. Leela S, and Dash SS, "Interline Dynamic Voltage Restorer Employing Wind Generator and Fuel Cell," International Journal of Applied Engineering Research, vol.11, no. 24, pp.2810-2815, 2016.
5. Fallah M, Kazemzadeh R, and Madadi Kojabadi H, "Performance improvement of DVR using a new numerical LPF based on VFF-RLS and fuzzy logic controller," Journal of Vibration and Control, vol.5, no.1, 2015.
6. Mishra S, "Power Quality Improvement Using Unified Power Quality Conditioner,"
7. Li P, Xie L, Han J, Pang S, and Li P, "New Decentralized Control Scheme for Dynamic Voltage Restorer Based on the Elliptical Trajectory Compensation," IEEE Transactions on Industrial Electronics, 2017.
8. Messiha MA, Baraket CF, Massoud AM, Iqbal A, and Soliman R, "Voltage sag mitigation employing dynamic voltage restorer with minimum energy requirements: Analysis and implementation,"
9. Kavousi-Fard A, Niknam T, and Fotuhi-Firuzabad M, "A Novel Stochastic Framework Based on Cloud Theory and  $\theta$ -Modified Bat Algorithm to Solve the Distribution Feeder Reconfiguration," IEEE Transactions on Smart Grid, vol.7, no.2, pp.740-750, 2016.
10. Sultana U, Khairuddin AB, Aman MM, Mokhtar AS, and Zareen N, "A review of optimum DG placement based on minimization of power losses and voltage stability enhancement of distribution system," Renewable and Sustainable Energy Reviews, vol.63, no.1, pp.363-378, 2016.
11. Bastos AF, Santoso S, and Biyikli L, "Analysis of power factor over correction in a distribution feeder," In the proceedings of Transmission and Distribution, pp. 1-5, 2016.
12. Naidu PV, Basavaraja B, and Reddy AR, "Design of a hysteresis voltage control based Interline DVR (IDVR) with VA optimization," In the proceedings of Power, pp. 1-6, 2014.
13. Suresh P, and Baskaran B, "Voltage Sag Compensation in Fourteen Bus System during Line Interruption Using Interline Dynamic Voltage Restorer," Indonesian Journal of Electrical Engineering and Computer Science, vol. 7, no. 3, 2017.
14. Arumugom S, and Rajaram M, "Enhanced High Performance Power Compensation Methodology by IPFC Using PIGBT-IDVR," The Scientific World Journal, 2015.
15. Prasad M, and Akella AK, "Mitigation of Power Quality Problems Using Custom Power Devices: A Review," Indonesian Journal of Electrical Engineering and Informatics (IJEEI), vol.5, no.3, pp.207-235, 2017.
16. Moradlou M, and Karshenas HR, "Design strategy for optimum rating selection of interline DVR," IEEE Transactions on Power Delivery, vol.26, no.1, pp.242-249, 2011
17. Ali S, Chauhan YK, and Kumar B, "Study & performance of DVR for voltage quality enhancement," In the proceedings of Energy Efficient Technologies for Sustainability pp. 983-988, 2013.
18. Jindal AK, Ghosh A, and Joshi A, "Power quality improvement using interline voltage controller," IET generation, transmission & distribution, vol. 1, no. 2, pp.287-293, 2007.
19. Jindal AK, Ghosh A, and Joshi A, "Voltage regulation using dynamic voltage restorer for large frequency variations," In the proceedings of Power Engineering Society General Meeting, pp. 850-856, 2005.
20. Kargarian A, Yavarian AR, and Khorrami RS, "Virtual smoothing load duration curve in distribution system operation using IDVR. System," pp.5-6, 2011.
21. Moradlou M, Bigdeli M, Siano P, and Jamadi M, "Minimization of interline dynamic voltage restorers rated apparent power in an industrial

- area consisting of two independent feeders considering daily load variations,” *Electric Power Systems Research*, vol.149, no. 1, pp.65-75, 2017.
22. Mahboubi-Moghaddam E, Narimani MR, Khooban MH, and Azizivahed A, “Multi-objective distribution feeder reconfiguration to improve transient stability, and minimize power loss and operation cost using an enhanced evolutionary algorithm at the presence of distributed generations,” *International Journal of Electrical Power & Energy Systems*, vol.76, no.1, pp.35-43, 2016.
23. Ding F, and Loparo KA, “Feeder reconfiguration for unbalanced distribution systems with distributed generation: a hierarchical decentralized approach,” *IEEE Transactions on Power Systems*, vol.31, no.2, pp.1633-1642, 2016.
24. M.R. Aswath Saravanan, Mr. C. Venkatesh Kumar, and M. Ramesh Babu, “power quality enhancement in distribution system using interline dynamic voltage restorer and displacement factor controller,” vol. 13, no. 1, 2015.
25. Li P, Xie L, Han J, Pang S, and Li P, “A New Voltage Compensation Philosophy for Dynamic Voltage Restorer to Mitigate Voltage Sags Using Three-Phase Voltage Ellipse Parameters,” *IEEE Transactions on Power Electronics*, vol. 33, no.2, pp.1154-1166, 2018.
26. Benoualid Medani, K., Sayah, S. and Bekrar, A., “Whale optimization algorithm based optimal reactive power dispatch: A case study of the Algerian power system”, *Electric Power Systems Research*, 2017.