

## Multifunctional Siren for Emergency Services

Cătălin Tudoran<sup>1</sup> Dan Andreiciuc<sup>2</sup> Aurel Filip<sup>3</sup>

**Abstract** – this paper presents a solution for the design of a multifunctional siren for emergency services (police, ambulance, special services etc). Such a device should have two functionalities: both as a voice amplifier and as a tone generator. When designing such a circuit, a D class amplifier has been considered for the amplification and a PIC microcontroller for the tone generation. A switch should be used to interchange these functionalities and user buttons must be provided for configuring the tone libraries.

**Keywords:** siren, class D amplifier, PIC, microcontroller

### I. INTRODUCTION

From the beginning of time, sounds have been used by every living being on this planet as a means of communication. By means of sounds we can communicate almost everything, from simple words to tones used in warning systems. From the physical point of view, sound is a vibration that propagates as a typically audible mechanical wave of pressure and displacement, through a medium such as air, and water. In physiology and psychology, sound is the reception of such waves and their perception by the brain. Sound waves are often simplified to a description in terms of sinusoidal plane waves, which are characterized by the following properties: frequency, wavelength, wavenumber, amplitude, sound pressure, sound intensity, speed of sound and direction. The human ear can only perceive sounds with frequencies between 20 Hz and 20 kHz with a maximum audibility around 3500 Hz. This interval is mainly influenced by the amplitude of the vibrations and the age and health of the individual.

### II. POWER AMPLIFIERS

An audio power amplifier is an electronic amplifier that amplifies low-power audio signals (signals composed primarily of frequencies between 20 - 20 000 Hz, the human range of hearing) to a level suitable for driving loudspeakers. It is the final electronic stage in a typical audio playback chain. Because power amplifiers are large-signal amplifiers, a much larger portion of the load line is used during signal operation than in a small-signal amplifier.

There are a few basic classes of power amplifiers: class A, class B, class AB, class C and class D. These amplifier classifications are based on the percentage of the input cycle for which the amplifier operates in its linear region. Each class has a unique circuit configuration because of the way it must be operated. The emphasis is on power amplification. Power amplifiers are normally used as the final stage of a communications receiver or transmitter to provide signal power to speakers or to a transmitting antenna.

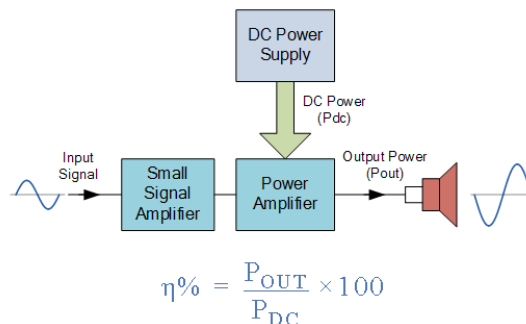

Fig.1. Basic example of a power amplifier, where:

- $\eta\%$  is the efficiency of the amplifier.
- $P_{out}$  is the amplifiers output power delivered to the load.
- $P_{dc}$  is the DC power taken from the supply.

#### A. Class A amplifiers

The Class A amplifier is the most common and simplest form of power amplifier that uses the simplest switching transistor in the standard common emitter circuit configuration. The transistor is always biased "ON" so that it conducts during one complete cycle of the input signal waveform producing minimum distortion and maximum amplitude to the output.

Both large-signal and small-signal amplifiers are considered to be class A if they operate in the linear region at all times. Class A power amplifiers are large-signal amplifiers with the objective of providing power (rather than voltage) to a load. As a rule of thumb, an amplifier may be considered to be a power amplifier if it is rated for more than 1 W and it is necessary to consider the problem of heat dissipation

<sup>1</sup> E-mail catalin.tudoran89@gmail.com

<sup>2</sup> Faculty of Electronics and Telecommunications, Applied Electronics Dept., Bd. V. Pârvan, 300223 Timisoara, Romania, e-mail dan.andreiciuc@upt.ro

<sup>3</sup> Faculty of Electronics and Telecommunications, Applied Electronics Dept., Bd. V. Pârvan, 300223 Timisoara, Romania, e-mail aurel.filip@upt.ro

in components. The maximum theoretical power efficiency of a Class A amplifier is between 25% and 50%, depending upon the type of output coupling used. The main disadvantage of power amplifiers and especially the Class A amplifier is that their overall conversion efficiency is very low as large currents mean that a considerable amount of power is lost in the form of heat.

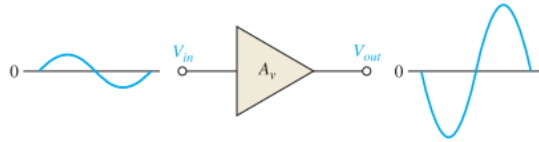

Fig.2. Basic class A amplifier operation. Output is shown 180° out of phase with the input (inverted)

### B. Class B and AB amplifiers

The class B amplifier operates in the linear region for 180° of the input cycle and is in cutoff for the rest of the 180° of the cycle. Class AB amplifiers are biased to conduct for slightly more than 180°. The primary advantage of a class B or class AB amplifier over a class A amplifier is that either one is more efficient than their class A counterpart, so as a result, you can get more output power for a given amount of input power. A disadvantage of class B or class AB is that it is more difficult to implement the circuit in order to get a linear reproduction of the input waveform. The term push-pull refers to the fact that two transistors are used on alternating half-cycles to reproduce the input waveform at the output.

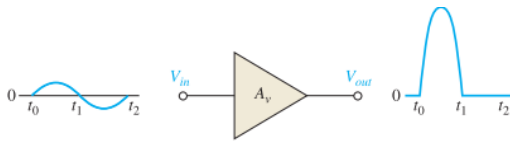

Fig.3. Basic class B amplifier operation (noninverting)

### C. Class C amplifiers

Class C amplifiers are biased so that conduction occurs for much less than 180°. Class C amplifiers are more efficient than either class A or push-pull class B and class AB, which means that more output power can be obtained from class C operation. The output amplitude is a nonlinear function of the input, so class C amplifiers are not used for linear amplification. They are generally used in radio frequency (RF) applications, including circuits, such as oscillators, that have a constant output amplitude, and modulators, where a high-frequency signal is controlled by a low-frequency signal. With class B, one needs to use a push-pull arrangement. That's why almost all class B amplifiers are push-pull amplifiers. With class C, one needs to use a resonant circuit for the load. This is why almost all class C amplifiers are tuned amplifiers.

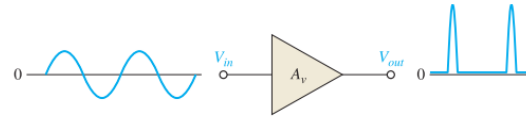

Fig.4. Basic class C amplifier operation (noninverting)

### D. Class D amplifiers

A class-D amplifier or switching amplifier is an electronic amplifier where all power devices (usually MOSFETs) are operated as binary switches. They are either fully on or fully off. Ideally, zero time is spent transitioning between those two states. Output stages such as those used in pulse generators are examples of class D amplifiers. However, the term mostly applies to power amplifiers intended to reproduce signals with a bandwidth well below the switching frequency. In Classes A, B and AB, the problem is lack of efficiency. Some power is wasted, and one would prefer that it could be sensibly employed in driving the loudspeakers to ever-higher sound pressure levels (or, at least, not converted to heat).

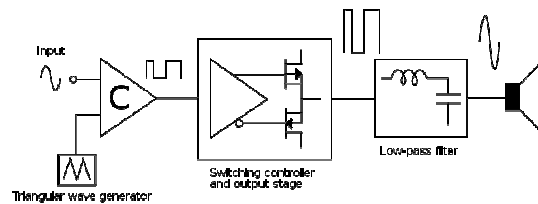

Fig.5. Block diagram of a basic switching or PWM (class D) amplifier

A Class D amplifier has three main stages, the first of which is the modulation stage. In a Class D amplifier, the signal must be converted to a digital signal before being amplified. There are several ways to accomplish this; the two most widely used are Pulse Width Modulation and Delta-Sigma ( $\Delta\Sigma$ ) Modulation. Each method has advantages and disadvantages. After the signal is modulated, it must be amplified. The amplification stage in a Class D amplifier uses several Metal Oxide Semiconductor Field Effect Transistors (MOSFETs), a different kind of transistor with very low power losses. The MOSFETs in a Class D amplifier can switch between fully on and fully off because they are amplifying a digital signal, avoiding the triode region where power efficiencies drop. When completely on in the active region, or completely off in the cutoff region, MOSFETs are theoretically lossless and in practice have very low power losses. After the modulated signal is amplified, it must be filtered before it can be sent to a speaker. The last stage is the filtering, or demodulation, stage, which consists of a low pass filter. This allows everything in the audible range (20 Hz - 20 KHz) to pass through, but significantly attenuates everything above 20 KHz. After being filtered, the signal is an amplified replica of the original input signal, and can be applied directly to a speaker.

What generally happens in class D amplifiers is that the transistors switch alternately to lift the output all the way up to the positive supply rail, then all the way down to the negative supply rail, as quickly as possible, with no in-between voltages. This is clearly going to be a pulse waveform. The secret to class D is that if the width of the pulses can be made proportional to the input signal's instantaneous level, the power delivered to the loudspeaker, averaged over time, will be the same as if the input signal had been amplified in the conventional way.

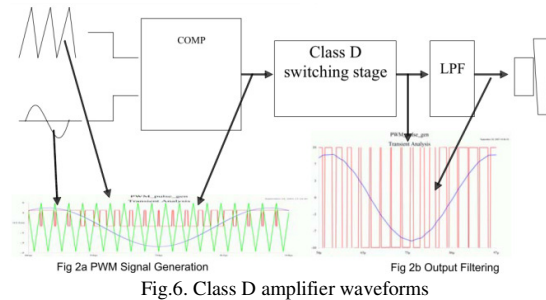

Fig.6. Class D amplifier waveforms

Generally speaking, class D amplification is achieved by modulating a signal, amplifying the modulated signal and then filtering the amplified signal back into its original form. Since Class D amplifiers work with digital signals, they do not require that the transistors involved operate in the triode region and, as a result, they are much more efficient than other amplifiers. This method of amplification has been used in portable audio devices, cell phones and low fidelity audio where size, power and heat dissipation are of great concern. The advantages of Class D, however, can also be applied to the larger systems required for live audio. The reduction in power consumption made possible by a Class D system is sometimes considered unnecessary for live audio because the size and efficiency of an audio system is not usually a concern when the system is permanently installed in a venue and the power is drawn from the wall. In our case, however, when we are speaking about emergency services and cars equipped with sirens and voice amplifiers, this advantage becomes very attractive. Class D amplifiers have historically only been used in a limited number of applications, like motor control, because it is more difficult to generate the high quality signals required for audio applications with a Class D amplifier. Recently, however, Class D technology has advanced sufficiently to allow these amplifiers to accurately and cleanly amplify audio signals. There are many advantages to using Class D amplifiers for audio applications, and the number of disadvantages is shrinking every year with further advances in technology.

### III. ADVANTAGES AND DISADVANTAGES OF CLASS D AMPLIFIERS

Further on, some advantages and disadvantages of Class D amplifiers will be presented. Despite the complexity involved, a properly designed class D amplifier offers the following benefits:

- reduced power waste as heat dissipation
- because of the above, a reduction in cost, size and weight of the amplifier due to smaller (or no) heat sinks, and compact circuitry
- very high power conversion efficiency, usually better than 90% above one quarter of the amplifier's maximum power, and around 50% at low power levels.

While Class D amplifiers have been in use for many years, only recently have they come to the forefront of audio amplification. This is because Class D amplifiers have a number of disadvantages that make them less suitable for audio amplification, though many of these have been overcome with recent advances in technology. One major disadvantage is that a Class D amplifier has a very high amount of high frequency noise, generated by the switching design. This noise must be kept at a high enough frequency to be inaudible, yet to a minimum amplitude to meet Federal Communications Commission (FCC) regulations. To help reduce extraneous noise, a filter is added after the amplifying stage. This filter is an additional component of the Class D amplifier, and adds complexity, weight, and cost. The added weight is negligible, however, when compared to the weight of the heat sink required for a Class A, Class AB or Class B amplifier. The additional cost of a filter may also be minimized using careful design techniques. Since the filter only needs to attenuate signals above the audible frequencies, it is not essential that the filter be extremely precise. The filter may therefore be realized by a fairly simple, low-pass, passive filter.

A second deficiency of Class D amplifiers is the increased complexity in design. This may result in increased design time and expense. Increased design expenses are generally considered acceptable, however, if the result is a lower manufacturing cost because design is singular expense, whereas manufacturing expenses are recurring. After the amplifier is designed, most of the components, with the possible exception of any inductors used in the filter and specialized MOSFETs in the power stage, are extremely inexpensive when purchased in bulk. So while the increased complexity seems like a major disadvantage, it may become irrelevant when the amplifiers are mass-produced.

The last major disadvantage of Class D amplifiers is that historically, distortion has been a major problem. High Total Harmonic Distortion (THD) is indicative of high noise levels, which detract significantly from the audio quality of the output. Advances in technology have allowed for faster modulation

techniques, however, which can reduce THD to fractions of a percentage in Class D audio amplifiers.

After consideration of advantages and disadvantages, the conclusion would be that such a Class D amplifier is ideal for use in vehicles and especially when equipping it for emergency services. Because of the light weight, low power consumption and relatively high quality output, it would serve the purpose of this project.

#### IV. THE TDA7498 AMPLIFIER

The TDA7498 is a dual BTL class-D audio amplifier with single power supply designed for home systems and active speaker applications. It comes in a 36-pin PowerSSO package with exposed pad up (EPU) to facilitate mounting a separate heat sink. Some of its features are described below:

- 100 W + 100 W output power at THD = 10% with  $R_L = 6 \Omega$  and  $V_{CC} = 36 V$
- 80 W + 80 W output power at THD = 10% with  $R_L = 8 \Omega$  and  $V_{CC} = 34 V$
- Wide range single supply operation (14 - 39 V)
- High efficiency ( $\eta = 90\%$ )
- Four selectable, fixed gain settings of nominally 25.6 dB, 31.6 dB, 35.1 dB and 37.6 dB
- Differential inputs minimize common-mode noise
- Standby and mute features
- Short-circuit protection
- Thermal overload protection
- Externally synchronizable

Such a device will have as input a microphone (for example, a CB Mic, because it has buttons for on/off and is portable) and as output, the loudspeakers. The device will amplify the sounds coming from the microphone when necessary.

#### V. THE PIC16F84A MICROCONTROLLER

The PIC16F84A is an 18-pin Enhanced FLASH/EEPROM 8-Bit Microcontroller. It belongs to the mid-range family of the PICmicro® microcontroller devices. Some of the features are described below:

##### A. High Performance RISC CPU Features

- Only 35 single word instructions to learn
- All instructions single-cycle except for program branches which are two-cycle
- Operating speed: DC - 20 MHz clock input DC - 200 ns instruction cycle
- 1024 words of program memory
- 68 bytes of Data RAM
- 64 bytes of Data EEPROM
- 14-bit wide instruction words
- 8-bit wide data bytes

- 15 Special Function Hardware registers
- Eight-level deep hardware stack
- Direct, indirect and relative addressing modes
- Four interrupt sources:
  - External RB0/INT pin
  - TMR0 timer overflow
  - PORTB<7:4> interrupt-on-change
  - Data EEPROM write complete

##### B. Peripheral Features

- 13 I/O pins with individual direction control
- High current sink/source for direct LED drive
  - 25 mA sink max. per pin
  - 25 mA source max. per pin
- TMR0: 8-bit timer/counter with 8-bit programmable prescaler

##### C. Special Microcontroller Features

- 10,000 erase/write cycles Enhanced FLASH Program memory typical
- 10,000,000 typical erase/write cycles EEPROM Data memory typical
- EEPROM Data Retention > 40 years
- In-Circuit Serial Programming™ (ICSP™) - via two pins
- Power-on Reset (POR), Power-up Timer (PWRT), Oscillator Start-up Timer (OST)
- Watchdog Timer (WDT) with its own On-Chip RC Oscillator for reliable operation
- Code protection
- Power saving SLEEP mode
- Selectable oscillator options

##### D. CMOS Enhanced FLASH/EEPROM Technology

- Low power, high speed technology
- Fully static design
- Wide operating voltage range:
  - Commercial: 2.0V to 5.5V
  - Industrial: 2.0V to 5.5V
- Low power consumption:
  - < 2 mA typical @ 5V, 4 MHz
  - 15  $\mu A$  typical @ 2V, 32 kHz
  - < 0.5  $\mu A$  typical standby current @ 2V

The above mentioned microcontroller will be used mainly for tone generation as C libraries exist that can facilitate the process of writing code.

#### VI. THE RESULT

The desired result of this project would be a working circuit that could fit into any vehicle. It's function would be two-fold: one as a siren and the other as a tone generator. A switch will be used to activate either one of these functions. Besides the button on the CB Microphone, which will activate the voice amplification, the device will have other buttons that control the siren function. When the siren

functionality is activated, the user should be able to switch between the different sound warning standards of the world. By pressing and holding a button, the device will enter a configuration mode and the user will be able to select the desired tones. After selection, the configuration mode can be exited with a long press of the same button. Apart from this, the device will be equipped with an ON/OFF switch and LED indicators that should indicate in which mode it is now and if the device is working properly.

## REFERENCES

- [1] Thomas L. Floyd, "*Electronic Devices*"
- [2] [http://www.electronics-tutorials.ws/amplifier/amp\\_5.html](http://www.electronics-tutorials.ws/amplifier/amp_5.html)
- [3] <http://www.mikroe.com/chapters/view/17/chapter-4-examples/#c4v1>
- [4] <http://en.wikipedia.org/wiki/Sound>
- [5] <http://highered.mcgraw-hill.com/sites/dl/free/007297527x/329094/malvinoch12.pdf>
- [6] [http://en.wikipedia.org/wiki/Class-D\\_amplifier](http://en.wikipedia.org/wiki/Class-D_amplifier)
- [7] Jun Honda & Jonathan Adams "*Application Note AN-1071 - Class D Audio Amplifier Basics*"
- [8] <http://www.soundonsound.com/sos/jun06/articles/loudandlight.htm>
- [9] Briana Morey, Ravi Vasudevan, Ian Woloschin, "*Class D Audio Amplifier - The design of a live audio Class D audio amplifier with greater than 90% efficiency and less than 1% distortion*", WORCESTER POLYTECHNIC INSTITUTE - May 2008
- [10] PIC16F84A microcontroller datasheet
- [11] TDA7498 amplifier datasheet