

# Experimental Study of Behavior to Transfer of an Heat Exchanger "Pipe-in-Pipe" Type

Delia Perju\*, M. Șuta\*, Adina Căta\*, Harieta Pîrlea\*

\*POLITEHNICA University of Timisoara, Department of Chemical Engineering, Piata Victoriei, nr. 2, Romania  
Author for correspondence: Delia Perju, e-mail: [delia.perju@rectorat.utt.ro](mailto:delia.perju@rectorat.utt.ro)

Usage of the actual analogue-digital systems allows the elaboration of news principles and methods for measurement (or improving the existing ones) for obtaining some excellence performing (high precisions, low dimensions). In this study the implementation of two such systems of measurement, which use two different methods from analogue-digital converting, for experimental study of behaviour to transfer of a heat exchanger, „pipe-in-pipe” type is presents. Using the mathematical analysis program MATLAB 6.5 and STATISTICA 6.0 for processing the experimental data, the correspondent mathematical models have been deduced.

Keywords: heat exchangers, measurement systems

## 1. Introduction

The principal characteristic of this decade is the penetration of the numerical systems in all domains. The decrease of the price, continue improving of the performance like increase work's speed and storage capacities, the possibility to realise a network at the world level, this are some examples for suggest that the digital systems are indispensable. In this context the appearance and development of the analogue-digital systems has been needed. The continuous request of such systems is the principal factor, which has determinate the research team to work in this domain. The two principal directions of development are: industrial applications and the ones for individual usage. The price, so the acquisition and usage of this depends to the request, performance, reliability, complexity of the programming languages.

A technological process needs the measurement and setting of varied parameters and of course the monitoring them. The research and development of the measurement systems follow improving of the existing ones and to find the news solutions.

In the chemical industry an important research direction is the heat transfer. This is justified by necessity to obtain best energetically efficiency and a very good manufacture price. The study of behaviour to transfer of them is a very actual direction, is very important to form the future chemical engineers and to elaborate the new technical solutions that will be applied in industry.

## 2. Experimental

The experimental installation that was used is presented in figure 1. The studied heat exchanger "pipe-in-pipe" type has two principles corps I and II and this are connected in opposition. The air circulates by internal pipe and the water for cooling circulates against current through the space between the two pipes. For decrease the waste for exterior the external pipe is isolated.

Through the heat exchanger circulates the air delivered by a bellows and this air is heated with a resistance  $R_1$  that

have input an adjustable tension  $U_a$ . The airflow  $Q_v$  (volumic) can be adjusted with control valve VR, the value of this can be measured by a diaphragm D. To stabilize the water flow  $Q_m$  (massic) will be used an automatic control system S.R.A.

The measurement of temperature in varied points of exchanger can be realised by many methods. In this study this measurement are realised with 8 thermocouples iron-constantan  $T_1-T_8$  (temperatures  $\theta_1-\theta_8$ ) and a thermal resistance  $T_r$  (temperature  $\theta_e$ ), positioned like in figure 1. The low dimensions of them have dictated the selection of thermocouples. Usage of the thermal resistance  $T_r$ , positioned at the exit of the exchanger and of the basis gauge TB (with temperature variation domain: 20-50 °C) lead to improving the measurement position. This solution is imposed because, in general for the heat exchanger, the exit temperature must be maintained constant, so the measurement systems will be used inside the very precise temperature control systems.

Two analogue-digital measurement systems, connected to the PC were used. The first system is built by the thermocouples  $T_1-T_8$ , entrance circuit T-21 and the analogue-digital system Actj [3] which determine a very good precision ( $\pm 1^\circ \text{C}$ ). The second system is built by thermal resistance  $T_r$ , the basis gauge TB and analogue-digital system AD-200.

The two process interfaces used communicate by the connecting couple with PC internal thoroughfare. Function principle, mode to used, statically and dynamically characteristics of tree measurement and control system have been presented in other scientific papers of the authors.[1,2,3,5]

## 3. Results and discussion

### ➤ Statically behaviour

Into industrial applications the product, which must be cooled, comes at a previous stage of the technological process. He is characterised by two principal parameters: flow and temperature.

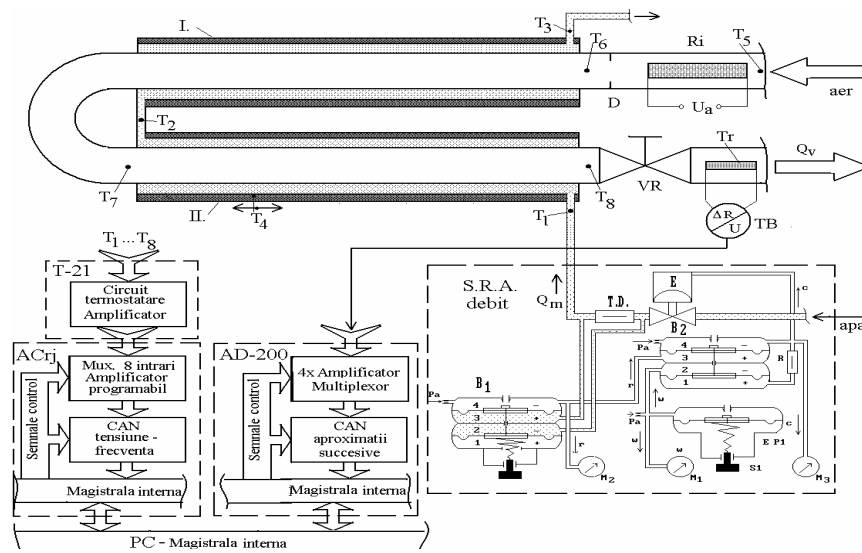

Fig. 1 Experimental installation

For the presented installation the air temperature  $\theta_6$  at the entrance of exchanger depend by entrance air temperature  $\theta_5$ , by the air flow  $Q_v$  and the power  $P$  emitted by resistance  $R_i$  ( $P=U_a^2/R_i$ ). The value for temperature  $\theta_6$  measured in stationary regime depending on  $Q_v$  and  $P$  were represented in figure 2. For obtaining the dependence relation (1) between the three variables (the entrance air temperature  $\theta_5$  is constant) a 2<sup>nd</sup> polynomial regression analysis made by STATISTICA 6.0 was realised.

$$\theta_6 = \theta_5 + [0,8 \times P - 0,001 \times P^2] - [2,7 \times (10^3 \cdot Q_v) + 4,5 \times (10^3 \cdot Q_v)^2] \quad (1)$$

were:  $\theta_5 = 16^\circ\text{C}$  (measured) and  $15,4^\circ\text{C}$  (analytical).

Observation: In figure 2 was represented the measured values of temperature  $\theta_6$  and also the dependence surface done by the mathematical model obtained.

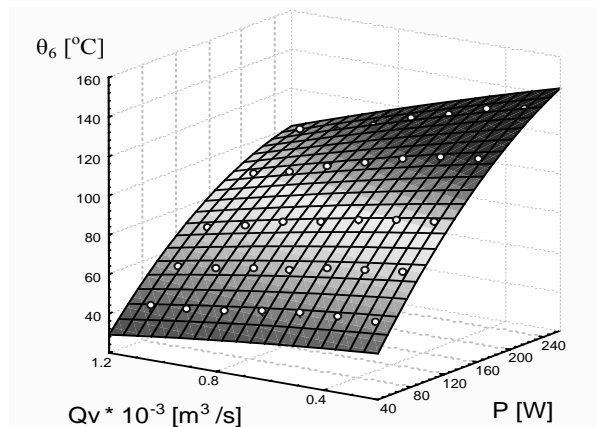

Fig. 2. Air temperature variation depending on  $Q_v$  and  $P$

For statically characterisation of heat exchanger the variation of the air and water temperature at entrance, middle and exit of the exchanger was studied, depending on:

- air flow  $Q_v$  (in this case the water flow is constant  $Q_m=0,4 \cdot 10^{-3}$  [Kg/s] – fig.3

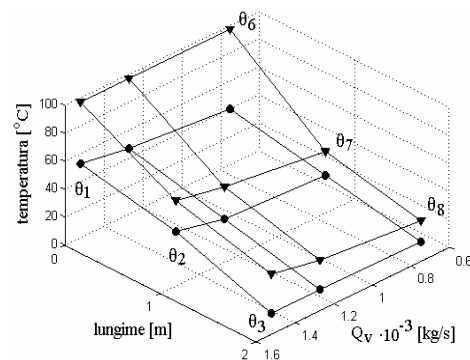

Fig.3. Air temperature and water for cooling temperature variation depending on  $Q_v$

- water flow  $Q_m$  (in this case the air flow is constant  $Q_v=1,44 \cdot 10^{-3}$  [m<sup>3</sup>/s] – fig.4

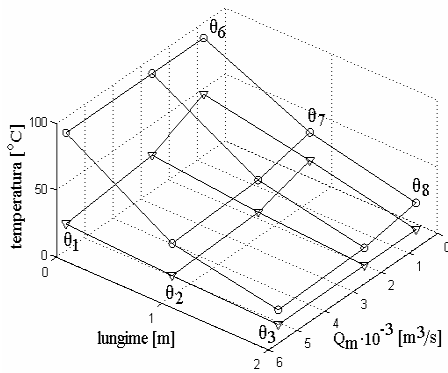

Fig. 4. Air temperature and water for cooling temperature variation depending on  $Q_m$

with  $\theta_6=97^\circ\text{C}$  (fig.3) and  $88^\circ\text{C}$  (fig.4) and water temperature  $\theta_1=14^\circ\text{C}$  constant.

By physical considerations, this installation doesn't allow the determination of the temperature in many points, at the different distances (depending on exchanger length). It is possible to determine this only at the entrance and exit of two corps I and II. The temperature variation depending on exchanger length however can be at the separation surface between the external pipe and the insulation surface.

In figure 5 the variation of temperature measured with thermocouple  $T_4$ , depending on exchanger length was represented.

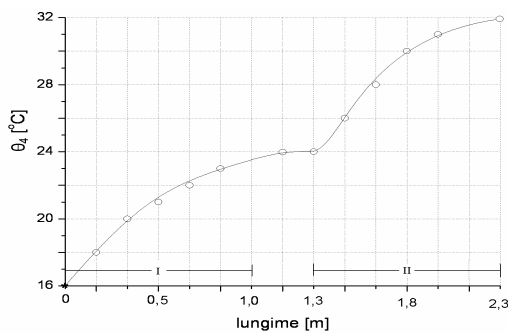

Fig. 5. Temperature variation  $\theta_4$  depending on exchanger length

Taking into account that this thermal regime is stationary, can be estimate that the measured temperature is approximately equal with water temperature. Because the heat exchanger is constructed with two corps I and II. The study of the statistically and dynamically must be taking into account this fact.

Observations: Even if the exponential shape of variation is specific from the heat transfer, in figures 3 and 4, because doesn't the intermediary point for temperature measurement, the temperature variation along exchanger has represented linear.

Static characterisation of the heat exchanger is useful to realise the thermal balance specific to heat transfer.

➤ Dynamically behaviour

For study the dynamically behaviour have used the second measurement system (figure 1) which are a high precision, obtained thank to proper choose of basis gauge TB (the domain of entrance temperature  $20\text{-}50^\circ\text{C}$ ; exit variable  $4\text{-}20\text{ mA}$ , precision:  $\pm 0.2^\circ\text{C}$ ).

Taking into account that in general the heat transfer can be modulated with 2<sup>nd</sup> differential linear and homogeneous equations which have exponential solution, for study dynamically behaviour of heat exchanger have been used the method: answer to the step signal. The experimental (temperature variation  $\theta_e$  to exit from the exchanger) was realised for:

- ❖ variation of heating power  $P$  in the shape of step signal (in this case the water flow  $Q_m$  is constant)

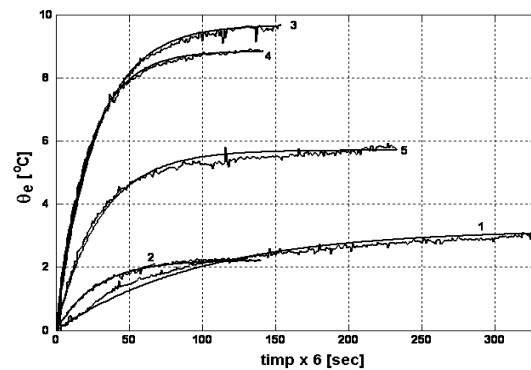

Fig. 6. Temperature variation in time to the step signal of heating power

- ❖ variation of cooling water flow  $Q_m$  in the shape of step signal (in this case the air flow  $Q_v$  is constant)

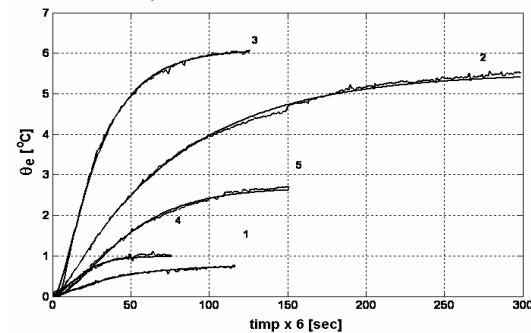

Fig. 7. Temperature variation in time of step signal of cooling water flow

The shape of temperature variation suggest that dynamically behaviour of heat exchanger is close by:

- ❖ 1<sup>nd</sup> proportional element for variation of heating power in the shape of step signal. In this case the

mathematical equation which describe the dynamically behaviour is:

$$\theta_1(t) = K_1 \cdot (1 - \varepsilon^{-t/T}) \quad (2)$$

Basis on the experimental determinations have been calculated: constant of time T, transfer coefficient K<sub>1</sub>, the results have presented in table 1.

- ❖ 2<sup>nd</sup> proportional element for variations of flow in the shape of step signal. In this case the

Nr. crt.	Modificare P						Modificare Q <sub>m</sub>						
	P <sub>1</sub> [W]	P <sub>2</sub> [W]	ΔP [W]	Q <sub>m</sub> ·10 <sup>-3</sup> [kg/s]	K <sub>1</sub>	T [sec]	P [W]	Q <sub>m1</sub> ·10 <sup>-3</sup> [kg/s]	Q <sub>m2</sub> ·10 <sup>-3</sup> [kg/s]	ΔQ <sub>m</sub> ·10 <sup>-3</sup> [kg/s]	K <sub>2</sub>	T <sub>1</sub> [sec]	T <sub>2</sub> [sec]
1	262	439	177	5.1	3	608	279	5.8	4.4	1.4	0.72	30	222
2	262	4389	177	2.5	2.25	162	279	4.4	1.2	3.2	5.7	32	444
3	272	433	159	7	9.6	162	279	6	1.2	4.8	6.0	42	150
4	279	433	154	7	8.8	132	279	6	3.2	2.8	0.98	60	60
5	279	378	99	7	5.7	180	279	3.2	1.7	1.5	2.7	118	186

For searching the numerical values of time constants from equations, which describe the answer to step signal, is used the minimisation of sum of the smaller square of the errors. These errors are the difference between experimental values and calculated values basis the model for the exit variable.

For obtaining a very good dynamical characterisation the acquisition period was 6 seconds and the value of one experiment represent the average of 1000 data (for eliminate the perturbations). This data was proceeding in MATLAB 6.5.

Another method to determine the dynamical characterisation of this system is the answer of this to the frequency. This method (determination of the transfer place) doesn't very used because technical difficulties appear: modification of exit variable (flow) in shape of sigmoid with variable frequency the determination of the attendance and deviation which correspond to exit variable (temperature) especially for high frequency.

#### 4. Conclusions

The dynamic of the numerical and analogue-digital system allows store and mathematical processing for many data. The evolution of the programming languages facilitates determination of some mathematical models, which have medium complexity. This models can estimate with very good precision the statically and dynamically behaviour of the physical-chemical system.

The elaborated study is an example for application of actual technologies in a very interesting domain, developed and improved along the history, that means heat transfer.

Variation of heated air temperature with an electrical resistance depending on airflow and heating power is an example from mathematical modelling in stationary regime.

mathematical equation which describe the dynamically behaviour is:

$$\theta_2(t) = K_2 \cdot \left(1 - \frac{T_1}{T_1 - T_2} \varepsilon^{-t/T_1} + \frac{T_2}{T_1 - T_2} \varepsilon^{-t/T_2}\right) \quad (3)$$

Table 1. Calculus of the coefficients K<sub>1</sub>, T, K<sub>2</sub>, T<sub>1</sub> and T<sub>2</sub>

Basis on the experimental determinations have been calculated: constants of time T<sub>1</sub>, T<sub>2</sub> transfer coefficient K<sub>1</sub> and the results have presented in table 1.

Usage of one analogue-system for measurement of the temperature in many points gives information about:

- ❖ the shape of variation in time
- ❖ exact value of this variation

The processing for obtaining data is useful to determine the shape of temperature variation, the time constants, which characterise the dynamically behaviour, to the study of thermal stability of the system, to realise the thermal balance, etc.

The complexity of heat transfer phenomena is demonstrates by the dispersion of the determinate parameters (K<sub>1</sub>, K<sub>2</sub>, T, T<sub>1</sub> and T<sub>2</sub>) for the studied experiment. This studies reflect that is very difficult to obtain a mathematical model relatively simple which can describe very well the dynamically behaviour of analysed heat exchanger.

#### References

1. Delia Perju , M. Șuta, Dana Silaghi-Perju, *Rev. Chim.* (București), vol. 51, Nr.12, **2000**, p. 919-923.
2. Delia Perju , M. Șuta, *Rev. Chim.* (București), vol. 55, Nr.1, **2004**, p. 42-46.
3. Delia Perju , M. Șuta, C. Rusnac, A. Brusturean, *Rev. Chim.* (București), vol. 54, Nr. 3, **2003**, p. 250-255.
4. Strawberry Tree: Data Acquisition System-User Manual, **1997**, p.3-16.
5. Delia Perju , M. Șuta, M. Geantă , Heat Transfer Process Computer Controlled, *Chem. Bul of Tehnical University Timișoara*, vol. 39 (53), **1994**, p. 85-92.
6. Delia Perju , M. Șuta, Characterization of the thermal transfer processes in the frequency range, *Chem. Bul Politehnica University Timișoara*, vol. 47 (61), vol. 1-2, **2002**, p. 55-57.