

Performance of Multi Binary Turbo-Codes on Nakagami Flat Fading Channels

Maria Kovaci¹, Alexandre de Baynast², Horia G. Balta¹, Miranda M. Nafornta¹

Abstract – In this paper, performance in terms of Bit Error Rate (BER) and Frame Error Rate (FER) of multi binary turbo codes (MBTC) over Nakagami frequency-nonselective fading channels are presented. The proposed MBTCs consist of the parallel concatenation of two identical 2/3-rate recursive systematic, convolutional (RSC) double binary codes. We choose to model the channel fading with Nakagami- m distribution since it fits well to the empirical fading data of the current wireless transmission systems. The simulation results show that the MBTCs outperform the classical turbo codes for low-targeted FER (around $10e-4$) since their error-floor is negligible.

Keywords: multi binary turbo code, flat fading channel, Nakagami distribution

I. INTRODUCTION

The multi-binary turbo-codes (MBTC) recently proposed by C. Douillard and C. Berrou [1], outperform the classical turbo-codes (TC) invented in 1993 by C. Berrou, A. Glavieux and P. Thitimajshima [2]. Indeed they show in [1] that parallel concatenation of r -input binary RSC codes offers several advantages versus to single-input-binary TCs over additive white Gaussian noise channel (AWGN) especially for their very low error-floor.

In this paper we investigate performance of the MBTC codes over fading channels. The fading phenomenon occurs in radio transmission channels and it is due to the presence of multiple paths that vary during the transmission, [3]. The transmission scheme that we considered in this paper is shown in Fig.1. The input-output relation of the transmission can be expressed as:

$$y_k = \alpha_k \cdot x_k + w_k, \quad (1)$$

where x_k and y_k are the transmitted and received data at time k , respectively; the parameter α_k is a random value which characterizes the fluctuations from symbol to symbol (fast fading) or from block to block (block fading) [4]. Its distribution determines the channel type: Rayleigh, Rice or Nakagami.

At the output of the encoder, the binary encoded sequence $\{u_k\}$ is mapped into a binary phase shift keying (BPSK) modulation. The resulting sequence $\{x_k\}$ is normalized such that it has unitary variance. The noise samples $\{w_k\}$ are assumed to be zero-mean independent identically distributed Gaussians with a variance equal to $\overline{w_k^2}$. This variance can be expressed as [5]:

$$\overline{w_k^2} = \frac{1}{2 \cdot 10^{SNR/10}}, \quad (2)$$

where SNR represents the signal-to-noise ratio in decibels.

Then, the coefficient α_k is equal to:

$$\alpha_k = \sqrt{\frac{\gamma_k}{SNR}}, \quad (3)$$

where γ_k is a Nakagami distributed random variable. The Nakagami- m distribution models well the fading in physical radio channels [6]. Through the parameter m , the Nakagami distribution can model various fading conditions that range from severe to moderate. A new accurate random number generator for Nakagami m distribution has been recently proposed in [5]. We use it to evaluate the behavior of the MBTCs over Nakagami flat fading channel. The simulation results are compared to the classical TC. The paper is organized as follows.

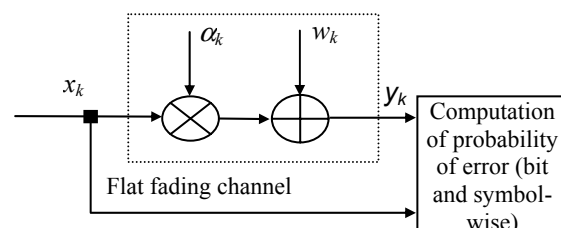

Fig.1 Considered transmission scheme over flat time-varying channels.

¹ Department of Communications, Faculty of Electronics and Telecommunications, Bd. V. Pârvan Nr. 2, 300223 Timișoara, e-mail: kmaria@etc.upt.ro, balta@etc.upt.ro, monica.nafornta@etc.upt.ro

² Department of Electrical and Computer Engineering, Rice University, MS-366-6100 Main Street, Houston, Texas 77005, e-mail: debaynas@rice.edu

In Section II the general scheme of the multi input convolutional encoder is presented. Section III describes the multi binary turbo-encoding scheme, and the advantages of this construction compare to the classical TC. Implementation issues are discussed in Section IV. Simulation results are presented in Section V and Section VI offers some concluding remarks.

II. MULTI BINARY CONVOLUTIONAL ENCODER

The main novelty of the MBTC compare to TC is the use of encoders with multiple inputs as component codes [1]. The general scheme of a multi input encoder (with $r/(r+1)$ rate) is presented in Fig.2.

Let $S_t = [s_m^t \dots s_2^t s_1^t]^T$ and $U_t = [u_r^t \ u_{r-1}^t \ \dots \ u_1^t]^T$ denote the encoder state and the r -component column input vector at time t , respectively. The operator $(\cdot)^T$ denotes the transpose of a vector. The full generator matrix of the multi input encoder has the following form:

$$H = \begin{bmatrix} h_{r+1,m} & h_{r,m} & \dots & h_{1,m} & h_{0,m} \\ \dots & \dots & \dots & \dots & \dots \\ h_{r+1,2} & h_{r,2} & \dots & h_{1,2} & h_{0,2} \\ h_{r+1,1} & h_{r,1} & \dots & h_{1,1} & h_{0,1} \end{bmatrix} \quad (4)$$

By eliminating first and last columns in matrix H , i.e. the weights for the redundant bit and the weights for the recursive part, we obtain the matrix H_0 as follows:

$$H_0 = \begin{bmatrix} h_{r,m} & \dots & h_{1,m} \\ \dots & \dots & \dots \\ h_{r,2} & \dots & h_{1,2} \\ h_{r,1} & \dots & h_{1,1} \end{bmatrix} \quad (5)$$

The feedback vector and the output vector have the form:

$$\begin{aligned} H_R &= [h_{0,m} \ \dots \ h_{0,2} \ h_{0,1}]^T \\ H_{out} &= [h_{r+1,m} \ \dots \ h_{r+1,2} \ h_{r+1,1}]^T. \end{aligned} \quad (6)$$

By using the previous notations, the main equation that describes the encoder shown in Fig.2 becomes:

$$(S_{t+1})_{m \times 1} = (H_0)_{m \times r} \cdot (U_t)_{r \times 1} + (T)_{m \times m} \cdot (S_t)_{m \times 1} \quad (7)$$

where the matrix T is defined as:

$$T = \begin{bmatrix} 0 & 1 & 0 & \dots & 0 & 0 \\ 0 & 0 & 1 & \dots & 0 & 0 \\ \dots & \dots & \dots & \dots & \dots & \dots \\ 0 & 0 & 0 & \dots & 0 & 1 \\ h_{0,m} & h_{0,m-1} & h_{0,m-2} & \dots & h_{0,2} & h_{0,1} \\ = \begin{bmatrix} 0_{m-1 \times 1} & I_{m-1} \\ H_R \end{bmatrix} \end{bmatrix} \quad (8)$$

The redundant output is equal to:

$$c^t = H_{out} \cdot S_t + W \cdot S_{t+1} \quad (9)$$

where the vector W is equal to $[0 \ 0 \ \dots \ 0 \ 1]_{1 \times m}$.

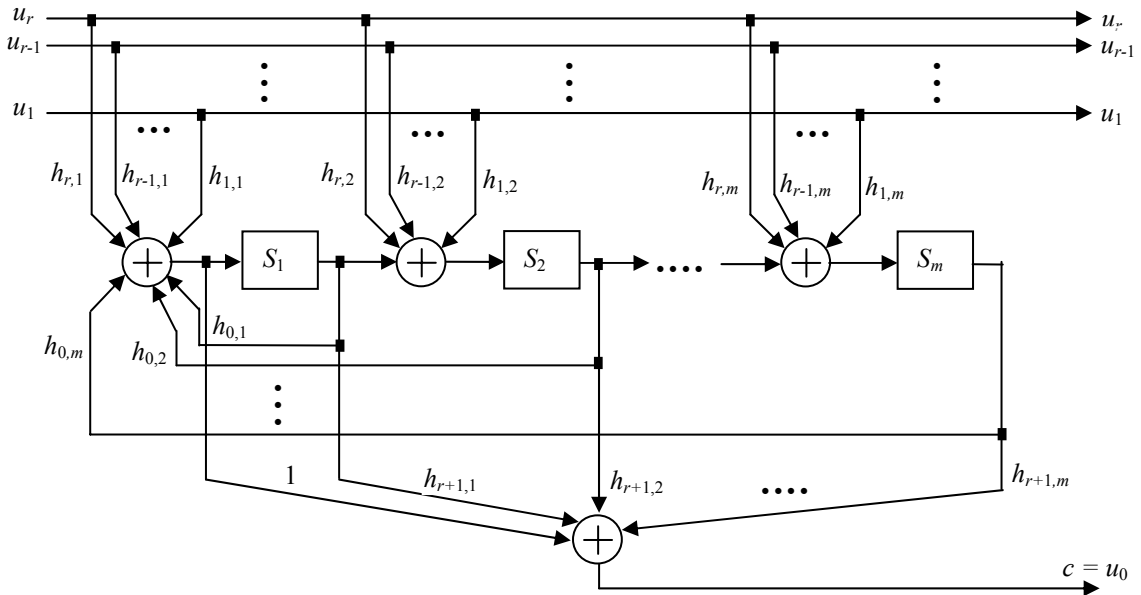

Fig. 2 Multi input convolution encoder – general scheme.

Throughout the paper, we consider a 16-state duo binary encoder, which has a larger minimum distance than an 8-state duo binary encoder. Therefore, we expect very good performance especially for low FER. Among the 16-state duo binary codes, we select the code with generator polynomials [11 11 1 12], which has been proposed in [1]. The memory of the encoder m is equal to 4 as shown in Fig. 3. For this particular code, the vectors S_t and U_t defined in Section II are equal to:

$$S_t = [s_4^t \quad s_3^t \quad s_2^t \quad s_1^t]^T \text{ and } U_t = [u_2^t \quad u_1^t]^T$$

and Equation (5) becomes:

$$H = \begin{bmatrix} 1 & 1 & 0 & 1 \\ 0 & 0 & 0 & 1 \\ 1 & 1 & 0 & 0 \\ 1 & 1 & 1 & 0 \end{bmatrix} = [11 \ 11 \ 1 \ 12]_{10}$$

We expressed here the matrix H in a compact form where each column of H is represented by a decimal value corresponding to its binary column-vector. Therefore, we have:

$$H_0 = \begin{bmatrix} 1 & 0 \\ 0 & 0 \\ 1 & 0 \\ 1 & 1 \end{bmatrix}, H_R = [1 \ 1 \ 0 \ 0], H_{out} = [1 \ 0 \ 1 \ 1]$$

The relations (7) and (8) can be rewritten as:

$$(S_{t+1})_{4 \times 1} = (H_0)_{4 \times 2} \cdot (U_t)_{2 \times 1} + (T)_{4 \times 4} \cdot (S_t)_{4 \times 1}$$

$$\text{with: } T = \begin{bmatrix} 0 & 1 & 0 & 0 \\ 0 & 0 & 1 & 0 \\ 0 & 0 & 0 & 1 \\ 1 & 1 & 0 & 0 \end{bmatrix}$$

This particular duo binary convolutional encoder is used for both constituent codes of the multi binary turbo coder that we proposed in the next section.

III. MULTI BINARY TURBO CODES

In this section, we propose a multi-binary turbo-code based on the parallel concatenation of two duo-binary convolutional encoders that have been described in the previous section. The main advantage of the multi-binary turbo-codes is their minimum distance, which generally is larger than for the classical TC. First we investigate the interleaver design for proposed the MBTC.

A parallel concatenation of two identical r -ary RSC encoders with an r -bit-word interleaver (Π) is presented in Fig. 4

For example, suppose that we indexed two input sequences of 5 binary words each ($r=2$) as they are entering into the corresponding encoder. At the output of the r -bit-word interleaver, we observe:

$\{\{1,3,5,7,9\}, \{2,4,6,8,10\}\} \xrightarrow{\Pi} \{\{5,1,9,3,7\}, \{6,2,10,4,8\}\}$
 Blocks of k bits (k being a multiple of r) are encoded twice by the bi-dimensional code, whose rate is $r/(r+2)$, to obtain a multi binary turbo encoder scheme in Fig.4.

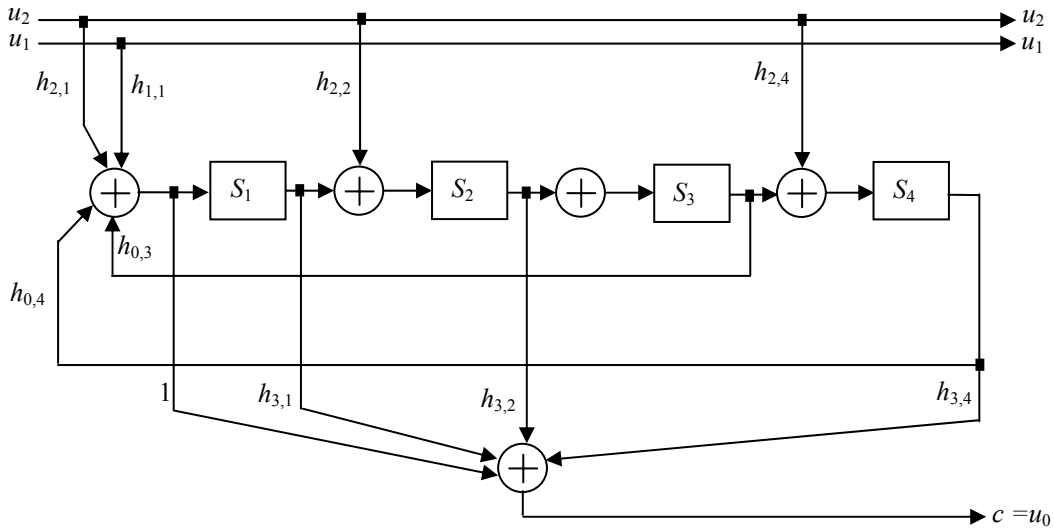

Fig. 3 The scheme of the 16-state duo binary encoder with $H=[11 \ 11 \ 1 \ 12]$.

In order to increase the minimum distance of the proposed code, we propose to use an additional symbol permutation for the 16-state duo-binary turbo code. The permutation parameters have been carefully chosen in order to maximize the minimum distance [1].

The permutation function $i = \Pi(j)$, is done in two steps.

For $j = 0, \dots, N-1$:

Step 1: the intra-symbol interleaver swaps $r_{j,1}$ and $r_{j,2}$ if $j \bmod 2 = 0$. Otherwise, no action is taken.

Step 2: the mapping of intersymbol interleaver is given by:

$$i = (P \times j + Q(j) + 3) \bmod N, \text{ with}$$

$$\begin{aligned} Q(j) &= 0 && \text{if } j \bmod 4 = 0 \\ Q(j) &= Q_1 && \text{if } j \bmod 4 = 1 \\ Q(j) &= 4Q_0 + Q_2 && \text{if } j \bmod 4 = 2 \\ Q(j) &= 4Q_0 + Q_3 && \text{if } j \bmod 4 = 3 \end{aligned} \quad (10)$$

with: $P=35, Q_0=1, Q_1=4, Q_2=4, Q_3=12$.

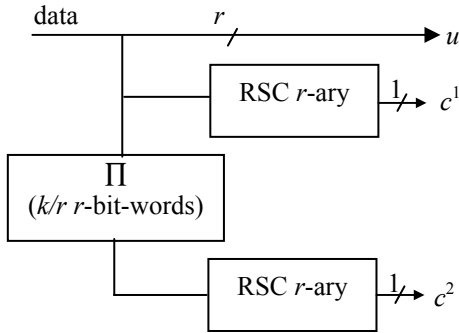

Fig. 4 The r -ary turbo-encoder proposed in [2].

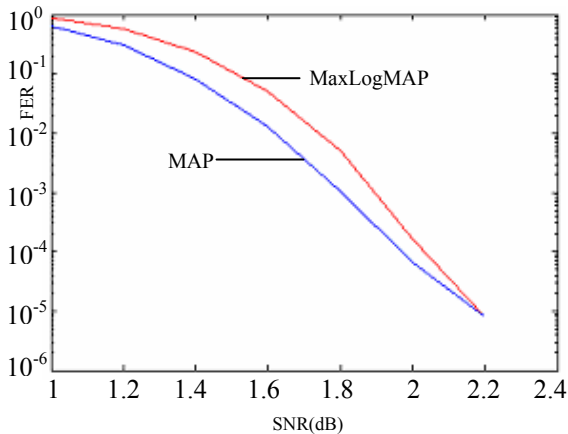

Fig. 5 Comparison between two implementations for the decoding algorithm of MBTCs over Nakagami-5 fading channel: MAP algorithm and MaxLogMAP approximation. In both cases, we evaluate the performance in terms of Frame Error Rate. The MBTC that we used is described in Fig. 4 (based on two 4-memory RSC codes). Codeword size is equal to 1504 bits with 1/2-rate.

IV. IMPLEMENTATION ISSUES

We decode the received sequence with the iterative decoding algorithm proposed in [7]. In this algorithm, computation of logarithms is required. To tackle this important issue, two approximations have been proposed in the literature [8]: 1) the logarithmic function is approximated by few values that are stored in a look-up table (LUT) of moderate size, 2) Max-Log-MAP [8] for which the log-function is approximated by the max function with some properly chosen offset coefficient. We choose the second solution for its robustness to fixed-point implementation. Interestingly, this algorithm converges slightly faster than the original MAP decoding algorithm [9].

In this section, we evaluate the performance loss due to the Max Log MAP approximation for the MBTCs over Nakagami-5 fading channel.

Fig.5 shows the FER performance of the rate-1/2: double binary 16-state TC as a function of SNR with both implementations: full MAP decoding algorithm [9] and the Max-Log-MAP decoding algorithm [8]. We consider a block size of 188 information bytes. For low SNR, the loss does not exceed 0.17 dB. Interestingly, for low FER (smaller than $10e-5$), the loss becomes negligible.

It is worth noting that the performance loss due to the Max-Log-MAP approximation is smaller for MBTC than for the classical TCs [1].

V. EXPERIMENTAL RESULTS

We consider the following setup for our simulations in Fig.6. The considered MBTC consists of the parallel concatenation of two identical rate 2/3 recursive, systematic, convolutional code (RSC) with a memory of 4 and with the encoding matrix H equal to $\begin{bmatrix} 11 & 11 & 1 & 12 \end{bmatrix}$. The trellis of the first encoder is closed at zero and the trellis of the second encoder is unclosed. The rate of this duo-binary turbo code is equal to 1/2. It is worth noting that no puncturing is needed. We used the interleaver described in the previous paragraph. The data block length, $k=2 \cdot N$, is equal to 188 bytes = 2×752 bits. In our simulation we assume QPSK signaling with perfect channel phase recovery at the receiver. As mentioned in the previous section, we used the Max-Log-MAP version of the decoding algorithm [8]. The extrinsic information is less reliable, especially at the beginning of the iterative process. A more robust approach consists in scaling the extrinsic information with a scaling factor smaller than 1.0. The best observed performance is obtained for a scaling factor of 0.75 instead of 0.7 [8] since the performance results are similar and 0.75 can be represented only with 2 bits. A maximal number of 15 iterations with a stopping criterion are used.

The transmission channel that we considered in our simulations is the m -Nakagami time selective channel. The performance of MBTC for Nakagami flat fading channels with $m > 1$ are upper bounded by the

performances over Rayleigh channel (which corresponds to the Nakagami flat fading channel with $m=1$, i.e. the most time-selective channel) and lower bounded by static channels (which corresponds to the Nakagami flat fading channel with $m=\infty$, i.e. time non-selective channel). We compare the performance of the proposed MBTC to the Shannon limit. For Gaussian inputs, the channel capacity for Nakagami flat fading channel with parameter m is given by Equation (6) in [10]. For binary inputs, achievable rate can be found in [11] for the particular cases: m equal to 1 (Rayleigh fading) and m equal to $+\infty$ (no fading, AWGN channel).

In Fig.6, we show that MBTC performs well over time-selective channels even for moderate codeword length (in our case, the codeword size is 1504 bits). Indeed, the performance loss from $m=\infty$ to $m=1$ does not exceed 3 dB for any FER and BER whereas the theoretical loss given by the Shannon limits is about 1.6 dB. This moderate additional loss is due to the fact we are using small codeword size.

In [1], the authors show by simulation that MBTC outperform classical TC over AWGN channel. We propose a similar comparison over Nakagami channels in Fig.7.

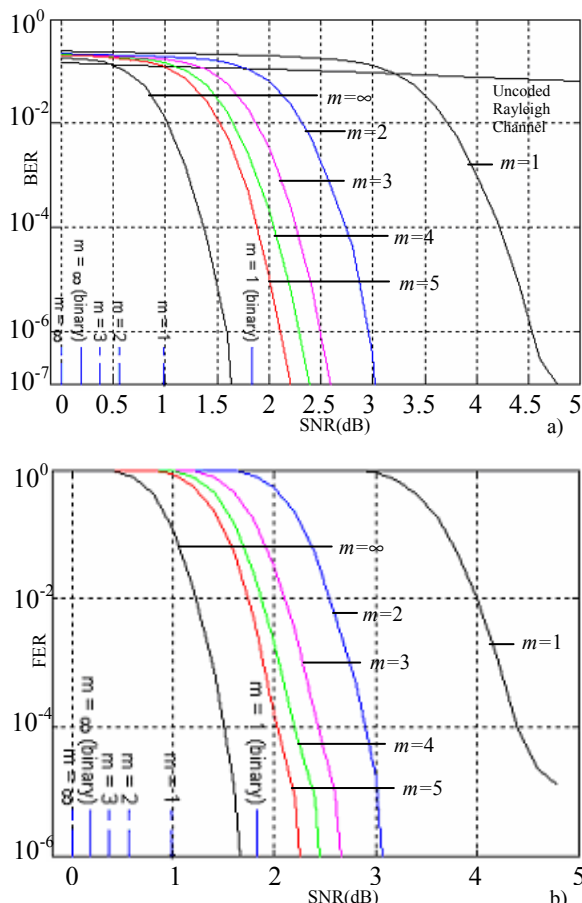

Fig. 6 Performance for Multi Binary Turbo-coded transmission over Nakagami flat fading channel: a) Bit Error Rate (BER), b) Frame Error Rate (FER), are plotted as functions of SNR for various fading parameters m . The thresholds corresponding to the Shannon limit for-Nakagami flat fading channels are also represented for several values of m (dashed line: Gaussian inputs; solid line: Binary inputs).

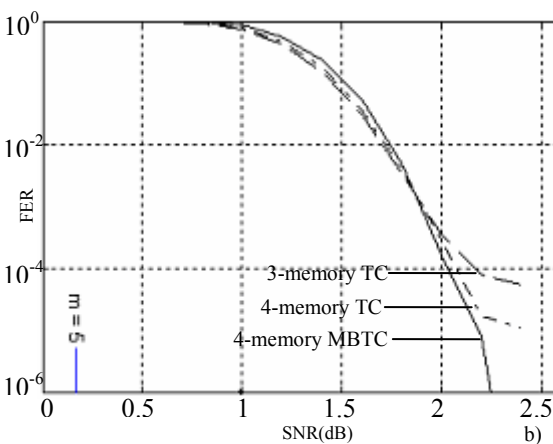
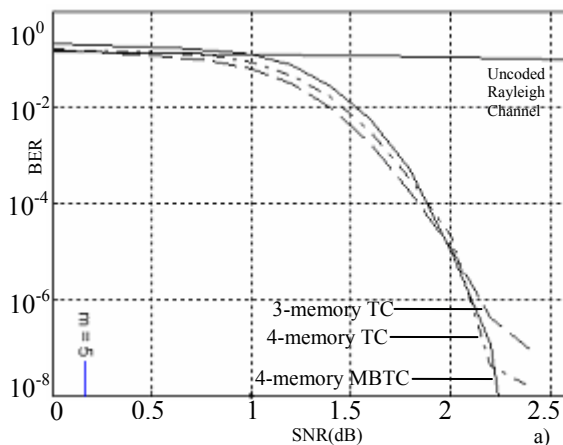

Fig.7 BER (a) and FER(b) performance for 4-memory MBTC, 3-memory and 4-memory classical TCs over Nakagami flat fading channel (fading parameter $m=5$), with the MAP decoding algorithm. Threshold corresponding to the Shannon limit with Gaussian inputs is also represented.

In Fig.7, we considered for all TCs a data block length k equal to 1504 bits, a rate $R=1/2$ and a fading parameter $m=5$ (severe time-selective channel). Thanks to the stopping criterion, the average number of iterations is about 3 iterations for a maximum number of iterations of 15. We assume QPSK modulation. For $5 \cdot 10^{-3} < FER < 10^{-5}$ performance of TCs and MBTCs are similar. Interestingly, for very low FER (let say roughly smaller than 10^{-5}), MBTCs do not exhibit any error floor to the contrary of the TCs thanks to their large minimum distance. This feature is particularly interesting in future wireless high data rate systems where high quality of service is required.

VI. CONCLUSIONS

In this paper we presented the BER and FER performance for 1/2-rate MBTC based on the Max-Log-MAP approximation over the m - Nakagami time selective channel. The channel models with Nakagami flat fading cover a large scale of practice situations from no time selectivity (AWGN channel) to very

severe time selectivity (Rayleigh channel). By simulations we show that MBTC performs well over time-selective channels even for moderate codeword length (in all simulations we assumed a codeword size of 188 bytes). In a future work, it would be interesting to evaluate the impact of the channel estimation error on the performance.

REFERENCES

- [1] C. Douillard, C. Berrou, "Turbo Codes With Rate- $m/(m+1)$ Constituent Convolutional Codes", *IEEE Transactions on Communications*, Vol. 53, No. 10, Oct. 2005, pp.1630-1638.
- [2] C. Berrou, A. Glavieux, P. Thitimajshima, "Near Shannon limit error-correcting coding and decoding: Turbo-codes", *Proc. ICC'93*, Geneva, Switzerland, May 1993, pp. 1064 – 1070.
- [3] John G. Proakis, "Digital communications", *McGraw-Hill Series in Electrical and Computer Engineering Stephen W.*, 2001.
- [4] A.J. Coulson, A.G. Williamson, R.G. Vaughan, "Improved fading distribution for mobile radio Communications", *IEE Proceedings*, Vol. 145, Issue 3, June 1998, pp.197 – 202.]
- [5] H. Balta, M. Kovaci, A. De Baynast " Performance of Turbo-Codes on Nakagami Flat Fading (Radio) Transmission Channels", *Signals, Systems and Computers, 2005. Conference Record of the Thirty-Ninth Asilomar Conference* on October 28 - November 1, 2005, pp. 606 – 610.
- [6] N. Beaulieu, C. Cheng, "Efficient Nakagami- m Fading Channel Simulation", *IEEE journal on Vehicular Technology*, vol. 54, no. 2, March 2005.
- [7] J. Hagenauer, E. Offer, L. Papke, "Iterative decoding of binary block and convolutional codes", *IEEE Transactions on Information Theory*, vol. 42, pp. 429-445, March 1996.
- [8] J. Vogt and A. Finger, "Improving the max-log-MAP turbo decoder," *Electron. Lett.*, vol. 36, no. 23, pp. 1937–1939, Nov. 2000.
- [9] L.R. Bahl, J. Cocke, F. Jelinek, and J. Raviv, "Optimal Decoding of Linear Codes for Minimising Symbol Error Rate", *IEEE Transactions on Information Theory*, Vol. 20, pp. 284-287, March 1974.
- [10] Jilei Hou; P.H. Siegel, L.B. Milstein, "Performance analysis and code optimization of low density parity-check codes on Rayleigh fading channels", *IEEE Journal on Selected Areas in Communications*, vol 19, Issue 5, pp. 924-934, May 2001.
- [11] Y.-D. Yao, A.U.H. Sheikh, "Investigations into cochannel interference in microcellular mobile radio systems", *IEEE Transactions on Vehicular Technology*, vol 41, pp. 114 - 123, May 1992.