

Tom 49(63), Fascicola 1, 2004

# Lowpass Active Filter Synthesis Based on Mesh Current Emulation of LC Ladder Structures

János Gal, Corina Naforniță and Andrei Câmpeanu<sup>1</sup>

**Abstract** – In a series of papers, [1]-[3], A. Câmpeanu and M. Naforniță proposed a new active RC filter synthesis method based on mesh current emulation of LC ladder filter networks. Initially, the method was successfully applied to highpass and lowpass polynomial filters. This paper extends the method to the very important class of lowpass finite-zeros (elliptic) filters.

Based on the mesh current method, a simple and systematic design table is proposed, which permits a direct active RC filter implementation of the passive network. It is also outlined a method of reducing the number of amplifiers required. Some results obtained using PSPICE simulation show the efficiency of the method and the importance of the results.

**Keywords:** RC active filter, LC ladder structure emulation, mesh current method, finite-zeros filter.

## I. INTRODUCTION

Because of their low-sensitivity properties, the double terminated lossless ladder filters are very suitable to be implemented as RC-active filters. The most used approach to the design of active filters based on LC ladder simulations is based on simulating the current voltage relationships existing in the LC-ladder prototype. This paper is specifically concerned with this kind of approach.

A. Câmpeanu and M. Naforniță [1]-[3], have given a procedure to derive an RC-active filter from the passive ladder network using the mesh currents description of the passive circuit. The proposed method used as building blocks, modified biquad resonator filter cells with multiple inputs to implement lowpass and highpass RC polynomial active filters. Here we propose an extension of the mesh currents simulation method to lowpass finite-zeros filters. For this very important case, most proposed RC-active filter synthesis methods for emulating high-order LC ladder filters are subject to either complicated design procedures or extra numbers of active elements. Mesh currents emulation active filters have the advantages that we can realize every loop in the original ladder prototype by a specific multiple-inputs multiple-outputs RC-active cell. Furthermore, a systematic design table to simplify the design procedures is established. The

multiple-inputs multiple-outputs RC-active cells are implemented using only conventional summation and integration devices. Moreover, the proposed filter cells use minimum numbers of op-amps.

## II. CIRCUIT TOPOLOGIES

The procedure for the mesh currents emulation method starts by taking an LC-ladder prototype network and slicing it into individual loops. We describe the work of the passive network presented in Fig.1 using mesh currents that flows in the loops of the network:  $I_1, I_2, \dots, I_n$ . Kirchoff's theorem applied in any of the network loops gives:

$$I_k = \frac{V_k}{Z'_k} + \frac{Z_{2k-2}}{Z'_k} I_{k-1} + \frac{Z_{2k}}{Z'_k} I_{k+1} \quad (1)$$

where  $Z'_k$  is the mesh impedance of the k-th loop.  $V_k$  represents the value of voltage sources in the same mesh. Only for  $k=0, V_k = E \neq 0$  and  $I_{k-1} = 0$ . For the last mesh of the network,  $I_{k+1} = 0$ .

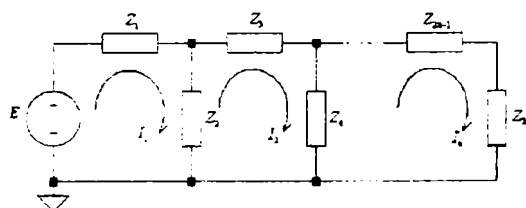

Fig. 1 Using mesh currents to describe the work of a passive ladder filter

According to (1), the ladder filter network can be implemented using RC active circuit cells with multiple inputs. Moreover, as the denominators of all the terms on the right side of (1) are identical,  $Z'_k$ , a unique active circuit structure can be used to implement the desired functions. As will be shown in the next Sections, depending the position of the loop in the ladder, the implementations are first or second order RC active circuits having multiple inputs and outputs.

Previous papers, [1]-[3], used T-shaped LC ladder structures to synthesize RC-active filters. This

<sup>1</sup> The authors are with Facultatea de Electronică și Telecomunicații, Departamentul Comunicații Bd. V. Pârvan Nr. 2, 300223 Timișoara, e-mail andrei.campeanu@etc.utt.ro

approach gives the advantage of using a unique active cell repeatedly for each loop of the passive structure. Extending the method to the case of finite-zeros filters, the previous approach becomes unsatisfactory because in a single circuit loop there are as far as two arms with LC resonant series circuits. A better solution is to use  $\pi$ -shaped passive filter structures, because in this case, each circuit loop has no more than a single LC resonant parallel circuit. This second approach is used in this paper unless it gives different transfer functions and different active filter cell structure for almost every loop of the original ladder prototype. Furthermore, in the next sections, systematic design rules are established to simplify design procedures.

### III. MESH CURRENTS SIMULATION OF LC LADDER BUILDING LOOPS

The examination of  $\pi$ -shaped double terminated passive filter structure has identified 5 distinct types of circuit loops. Based on the mesh currents description of a certain loop, the structure of equivalent RC-active cells with op amps was established. Instead of the original currents  $I_k$ , the RC-active cell work is described by potentials  $V_k$  having the same subscripts and superscripts as the original currents.

In the case of network loops having on series arms LC parallel circuits, the need of keeping the number of op amps in the synthesized cell to a minimum imposes the separation of the loop current,  $I_k$  in two terms, the first with a highpass behaviour,  $I_k'$ , the second one,  $I_k''$  behaving like a lowpass filter:

$$I_k = \alpha_k I_k' + I_k'' \quad (2)$$

where  $\alpha_k$  is a constant for a given loop.

According to (2), the output of the corresponding RC-active cell will be written in the same manner:

$$V_k = \alpha_k V_k' + V_k'' \quad (3)$$

Actually, the transposition of (3) in the active circuit cell means the use of two separate outputs for the same cell: a highpass output,  $V_k'$ , and a lowpass output,  $V_k''$ . Finally, the multiplication with  $\alpha_k$  and the addition of the two terms in (3) is made in the input stage of the adjacent cells which use as input signal the result of the equation. Consequently, the op amp needed to implement (3) is spared.

Next, the five distinct RC-active cells will be inferred starting from the passive circuit counterparts.

#### A. Input termination ladder network synthesis

The input termination of a  $\pi$ -shaped double

terminated passive filter is shown in Fig. 2. a. Taking as input variables  $E$  and the two parts of  $I_2$ ,  $I_2'$  and  $I_2''$ , the mesh current is expressed as

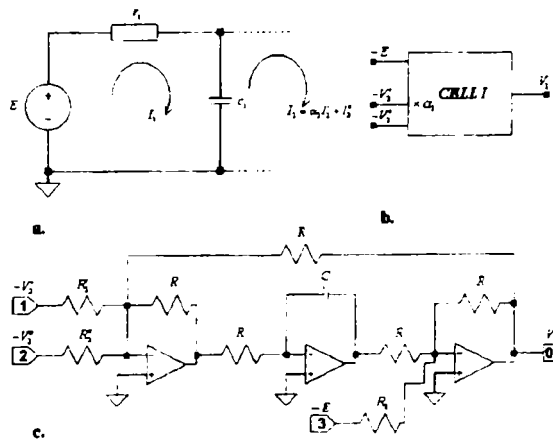

Fig. 2 a. Input loop of a  $\pi$ -shaped lowpass passive filter, b. Symbol of the equivalent active cell, c. Schematic of the synthesized filter cell.

$$I_1 = \frac{sC_2}{s\tau_1 C_2 + 1} E + \frac{\alpha_2}{s\tau_1 C_2 + 1} I_2' + \frac{1}{s\tau_1 C_2 + 1} I_2'' \quad (4)$$

This multiple-inputs first order transfer function, implemented in Fig. 2.c, has a similar transfer function.

The symbol used to represent the active cell is shown in Fig. 2.b. As in the next block symbols presented, the notation  $\times \alpha_2$ , used at the input  $-V_2'$ , indicates that the output  $-V_2'$  of the adjacent cell will be multiplied at this input by the coefficient  $\alpha_2$ .

Choosing the value of the resistor  $R$ , the other parts in the schematic are:

$$C_1 = \frac{\tau_1 C_2}{R}, \quad R_1 = R, \quad (5)$$

$$R_2' = R/\alpha_2, \quad R_2'' = R$$

#### B. The synthesis of the interior filter loops

For the  $\pi$ -shaped passive filters, there are two different topologies for the interior network loops.

The simplest one, used in polynomial filter networks, has a single reactive element on each arm of the mesh (Fig. 3. a). Depending on the adjacent loops currents,  $I_{k-1}$  and  $I_{k+1}$ , the mesh current  $I_k$  is expressed as

$$I_k = \frac{\frac{C_{2k-2}}{C_{2k-2} + C_{2k}} I_{k-1} + \frac{C_{2k}}{C_{2k-2} + C_{2k}} I_{k+1}}{s^2 I_{2k-1} \frac{C_{2k-2} C_{2k}}{C_{2k-2} + C_{2k}} + 1} \quad (6)$$

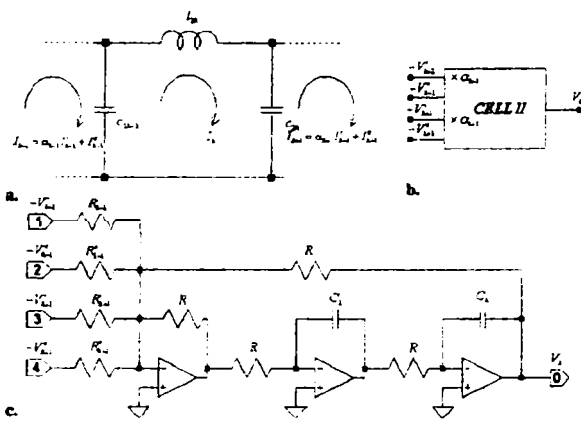

Fig. 3 a. An internal loop of a polynomial  $\pi$ -shaped lowpass passive filter, b. Symbol of the equivalent active cell, c. Schematic of the synthesized filter cell.

The corresponding active filter cell, named *CELL II*, Fig. 3.c., synthesizes the same transfer function in a 3 op amps RC lowpass undamped circuit. The circuit exhibits as far as 4 inputs required to satisfy a possible decomposition of the adjacent loops currents just like in (2). The design relationships are now:

$$\begin{aligned}
 R'_{k-1} &= \frac{c_{2k-2} + c_{2k}}{c_{2k} \alpha_{k-1}} R, & R''_{k-1} &= \frac{c_{2k-2} + c_{2k}}{c_{2k}} R, \\
 R'_{k+1} &= \frac{c_{2k-2} + c_{2k}}{c_{2k-2} \alpha_{k+1}} R, & R''_{k+1} &= \frac{c_{2k-2} + c_{2k}}{c_{2k-2}} R, \\
 C_k &= \sqrt{\frac{I_{2k-1} c_{2k-2} c_{2k}}{c_{2k-2} + c_{2k}}} R
 \end{aligned} \quad (7)$$

The previous expressions suppose that  $R$  has a known value.

The interior loops of finite-zeros lowpass filter include on the series arms, LC parallel circuits as shows Fig. 4. a.

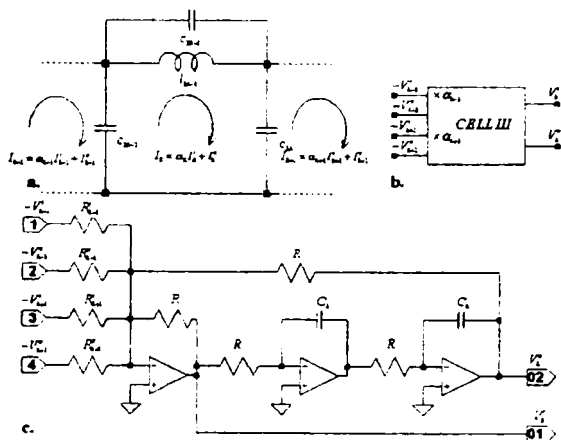

Fig. 4 a. An internal loop of a finite-zeros  $\pi$ -shaped lowpass passive filter, b. Symbol of the equivalent active cell, c. Schematic of the synthesized filter cell.

As the dependence of the mesh current  $I_k$  from the currents of the neighbouring cells,  $I_{k-1}$  and  $I_{k+1}$ ,

reveals an undamped second order rational transfer function with finite-zeros, the complete synthesis of this function in the *CELL III* circuit will require a supplementary amplifier. Instead of this solution, we preferred to use eq. (2) and (3) and the synthesized circuit exhibits two outputs,  $V'_k$  and  $V''_k$  (see Fig. 4.b.). The multiplication with  $\alpha_k$  and the addition of the two outputs of *CELL III* is made in the input stage of the adjacent cells. The components  $I'_k$  and  $I''_k$ , together with the constant  $\alpha_k$  have the following expressions:

$$\begin{aligned}
 I'_k &= \frac{s^2 \left( \frac{c_{2k}}{c_{2k-2} + c_{2k}} I_{k-1} + \frac{c_{2k-2}}{c_{2k-2} + c_{2k}} I_{k+1} \right)}{s^2 + \frac{1}{\left( c_{2k-1} + \frac{c_{2k-2} c_{2k}}{c_{2k-2} + c_{2k}} \right) I_{2k-1}}} \\
 I''_k &= \frac{\frac{c_{2k}}{c_{2k-2} + c_{2k}} I_{k-1} + \frac{c_{2k-2}}{c_{2k-2} + c_{2k}} I_{k+1}}{s^2 \left( c_{2k-1} + \frac{c_{2k-2} c_{2k}}{c_{2k-2} + c_{2k}} \right) I_{2k-1} + 1} \quad (8)
 \end{aligned}$$

$$\alpha_k = \frac{c_{2k-1}}{c_{2k-1} + \frac{c_{2k-2} c_{2k}}{c_{2k-2} + c_{2k}}}$$

Finally, to design the RC-active filter cell, the following relationships will be used:

$$\begin{aligned}
 R'_{k-1} &= \frac{c_{2k-2} + c_{2k}}{c_{2k} \alpha_{k-1}} R, & R''_{k-1} &= \frac{c_{2k-2} + c_{2k}}{c_{2k}} R, \\
 R'_{k+1} &= \frac{c_{2k-2} + c_{2k}}{c_{2k-2} \alpha_{k+1}} R, & R''_{k+1} &= \frac{c_{2k-2} + c_{2k}}{c_{2k-2}} R, \\
 C_k &= \sqrt{\frac{I_{2k-1} \left( c_{2k-1} + \frac{c_{2k-2} c_{2k}}{c_{2k-2} + c_{2k}} \right)}{R}} \quad (9)
 \end{aligned}$$

In (9), we suppose the value of  $R$  being chosen.

### C. Output termination ladder network synthesis

There are two different topologies for the terminal loops of  $\pi$ -shaped lowpass LC ladder filters, depending on the order of the filter.

One o.e. file.s (Fig. 5.) exhibits the simplest terminal loop. The dependence between the terminal loop current,  $I_n$  and the previous loop current  $I_{n-1}$  is expressed by a first order lowpass transfer function:

$$I_n = \frac{1}{s c_{n-2} r_{n-1} + 1} I_{n-1} \quad (10)$$

The synthesized active cell filter and the symbol used for the cell are shown in Fig. 5. b. and c. Choosing the value of the resistor  $R$ , the other parts in the circuit are given by

$$\begin{aligned}
 R'_{n-1} &= R/\alpha_{n-1}, & R''_{n-1} &= R \\
 C_n &= r_{n-1} c_{n-2}/R \quad (11)
 \end{aligned}$$

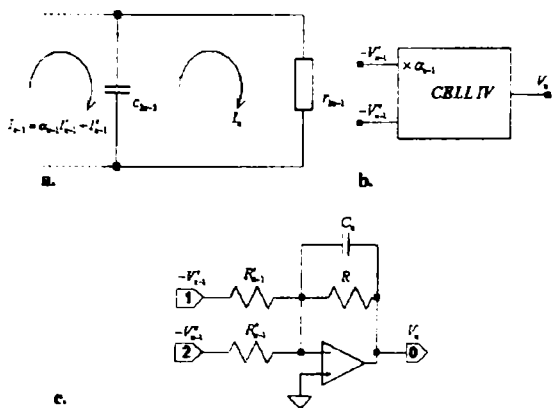

Fig. 5 a. Output loop of a  $\pi$ -shaped odd order lowpass passive filter, b. Symbol of the equivalent active cell, c. Schematic of the synthesized filter cell.

A more complicated dependence between the output loop current,  $I_n$  and the previous loop current  $I_{n-1}$  is obtained in the case of even order LC ladder network filters (see Fig. 6.a.). It's a lowpass second order function:

$$I_n = \frac{\alpha_{n-1} I'_{n-1} + I''_{n-1}}{s^2 c_{n-2} l_{n-1} + s c_{n-2} r_n + 1} \quad (12)$$

The CELL V active circuit, Fig. 6.b, is built on the structure of a modified lowpass resonator filter with three op-amps. Being given a value for  $R$ , the design relationships for the discrete parts of the cell are also very simple to infer:

$$C_n = \frac{\sqrt{c_{n-2} l_{n-1}}}{R}, \quad R_n = \sqrt{\frac{l_{n-1}}{c_{n-2}}} \frac{R}{r_n} \quad (13)$$

$$R'_{n-1} = \frac{R}{\alpha_{n-1}}, \quad R''_{n-1} = R.$$

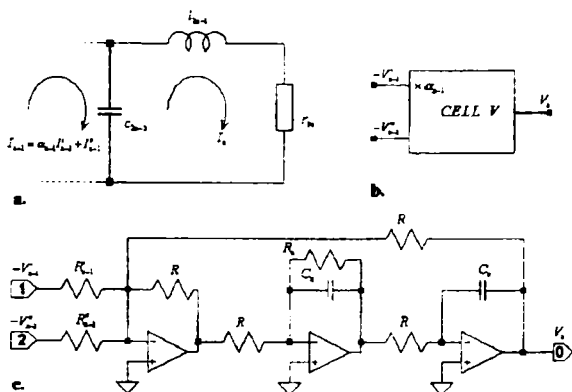

Fig. 6. a. Output loop of a  $\pi$ -shaped even order lowpass passive filter, b. Symbol of the equivalent active cell, c. Schematic of the synthesized filter cell.

#### IV. DESIGN PROCEDURE AND SIMULATION RESULT

The design procedure of an RC-active filter based on the mesh currents emulation method is straightforward. First, divide the original ladder prototype in distinct loops and choose appropriate filter cells among the cells introduced in the previous Section. Next, connect neighbouring cells with

appropriate interconnections. Finally, determine the values of resistors and capacitances via the derived design relationships.

To demonstrate the flexibility of the proposed active filters cells, a fifth-order LC elliptic lowpass filter is realized. Its prototype is shown in Fig. 7.a., with 0.1dB ripple and minimum 43dB attenuation in the stopband, will have 10kHz bandwidth.

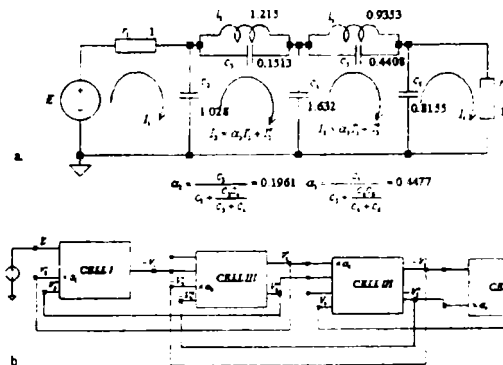

Fig. 7 a. Fifth-order LC filter prototype, b. The corresponding RC-active filter derived from the prototype on the basis of mesh currents emulation method.

Fig. 7. b. shows the implementation of the LC ladder network filter at the active filter cell level. The synthesis employs a total number of 10 op amps. The simulation of the active circuit employed LT 1057 op amps and gave the result shown in Fig. 8.

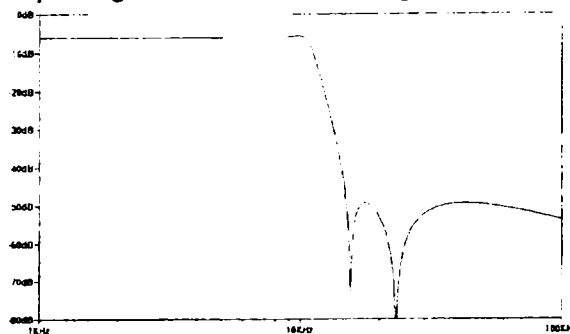

Fig. 8 Amplitude response of the active circuit from Fig. b.

#### V. CONCLUSIONS

A new passive filter implementation based on mesh currents emulation of LC ladder networks was introduced for finite-zeros lowpass filters. Design principles and procedures jointly with the result of a circuit simulation are also presented.

#### REFERENCES

- [1] A. Cămpeanu and M. Nafornită, "Implementation of HP filters by a leapfrog realization", Proc. Intern. Conf. On Microelectron. and Comp. Science, Kishinev, Moldavia, pp. 174-177, Oct. 21-23 1992.
- [2] A. Cămpeanu and M. Nafornită, "A new biquad cell improves the performance of a high-pass filter", Bul. Tehnic Univ. Tehnice Timișoara, tom 38 (52), pp. 231-238, 1993.
- [3] A. Cămpeanu and M. Nafornită, "Multiple-inputs active filter cells for a new leap-frog filter structure", Proc. ECCTD '95 European Conf. on Circ. Theory & Design, pp. 623-626, Istanbul, Turkey, August 1995.