

**UNIVERSITATEA "POLITEHNICA "TIMISOARA
FACULTATEA DE MECANICA**

617.595/6
180 c

inginer Adriana Minerva MOTICA

Teza de doctorat

**"OPTIMIZAREA STRUCTURILOR DE REZISTENTA ALE MASINILOR UNELTE
PRIN PROIECTAREA ASISTATA DE CALCULATOR CU METODE NUMERICE
APLICATII PE STRUNGURI NORMALE"**

Anexa C

BIBLIOTECA CENTRALA
UNIVERSITATEA "POLITEHNICA"
TIMIȘOARA

Conducator stiintific Profesor dr.ing Ionel DOBRE

1996

CUPRINS

Calcul static-Program I-DEAS MS 1.2	
Calcul static varianta fara picior ,10mm (tensiuni dupa Mises,tensiuni tangentiale, tensiuni principale,energie de deformatie)	C1-C5
Calcul static varianta fara picior ,15mm (tensiuni dupa Mises,tensiuni tangentiale, tensiuni principale,energie de deformatie)	C6-C9
Calcul static varianta cu picior ,10mm (tensiuni dupa Mises,tensiuni tangentiale, tensiuni principale,energie de deformatie)	C10-C12
Calcul static varianta cu picior ,15mm (tensiuni dupa Mises,tensiuni tangentiale, tensiuni principale,energie de deformatie)	C13-C16
Calcul dinamic-Program MARC-MENTAT II	
Sectiunile si punctele de calcul de pe batiu	C17
Fortele de pe batiu (dir.x,y,z)	C18-C21
Varianta stru_f4-10 incrementi-tensiuni dupa Mises	C22-C32
Varianta stru_f4 tensiuni principale(tensiuni dupa dir.1,2,3)	C33-C35
Varianta stru_f2-10 incrementi-tensiuni dupa Mises	C36-C46
Varianta stru_f2 tensiuni principale(tensiuni dupa dir.1,2,3)	C47-C49
Varianta stru_f-10 incrementi-tensiuni dupa Mises	C50-C60
Varianta stru_f tensiuni principale(tensiuni dupa dir.1,2,3)	C61-C63
Varianta stru_f5-10 incrementi-tensiuni dupa Mises	C64-C74
Varianta stru_f5 tensiuni principale(tensiuni dupa dir.1,2,3)	C75-C77
Varianta stru_f3-10 incrementi-tensiuni dupa Mises	C78-C88
Varianta stru_f3 tensiuni principale(tensiuni dupa dir.1,2,3)	C89-C91
Varianta stru_f1-10 incrementi-tensiuni dupa Mises	C92-C102
Varianta stru_f1 tensiuni principale(tensiuni dupa dir.1,2,3)	C103-C105
Variante substructurare-Program I-DEAS MS 2.0	
varianta 1	C106
varianta 12	C107
varianta 2	C108
varianta 3	C109
varianta 31	C110
varianta 4	C111
varianta 41	C112
varianta 5	C113
varianta 51	C114
varianta 6	C115
varianta 61	C116
varianta 7	C117
varianta 71	C118

CALCUL STATIC BATIU VARIANTA FARA PICIOR

TENSIUNI VON MISES

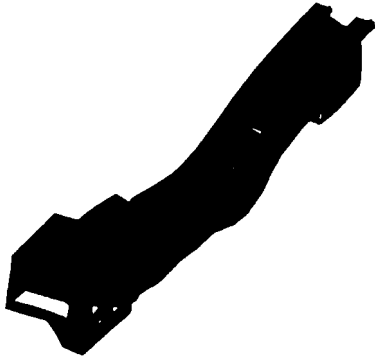

TENSIUNI PRINCIPALE

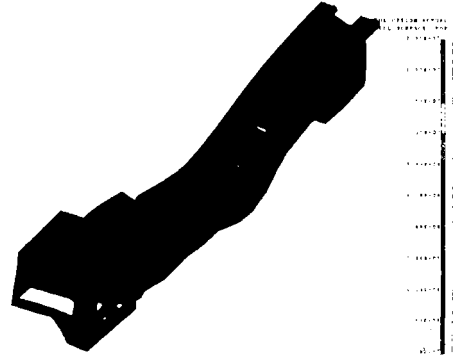

TENSIUNI TANGENTIALE

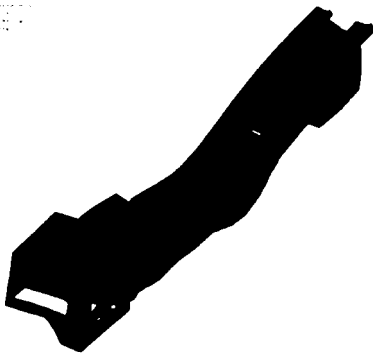

ENERGIE DE DEFORMATIE

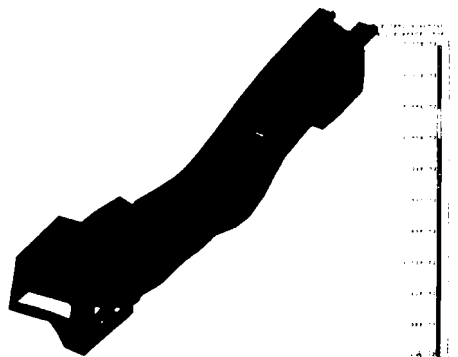

/users/itzam/tick.rfl

RESULTS: 1. S.C. 2.LOAD 1.STRESS.2
STRESS: MAX PRIN MIN: 1.72E+07 MAX: 3.81E+07
DEFORMATION: 1. R.C. 2.LOAD 1.DISPLACEMENT.1
DISPLACEMENT: MAX MIN: 0.30E+00 MAX: 3.95E+04
FRAME OP. REF: PART



NAME: STRESS:ACTON...
ELEMENT SURFACE: TOP

3.81E+07
3.28E+07
2.71E+07
2.15E+07
1.60E+07
1.04E+07
4.91E+06
6.28E+05
8.16E+04
1.17E+07
1.72E+07

/suffr/12ans/1202A.rmt

RESULTS 3 B.C. 2.1000 1.5000000000000000
STRAIN ENERGY 505.0000 3.175E+02 MAXI 1.44E+02
DEFORNATION B.C. 2.1000 1.5000000000000000
DISPLACEMENT MAXI MINI 0.228E+02 MAXI 3.175E+02

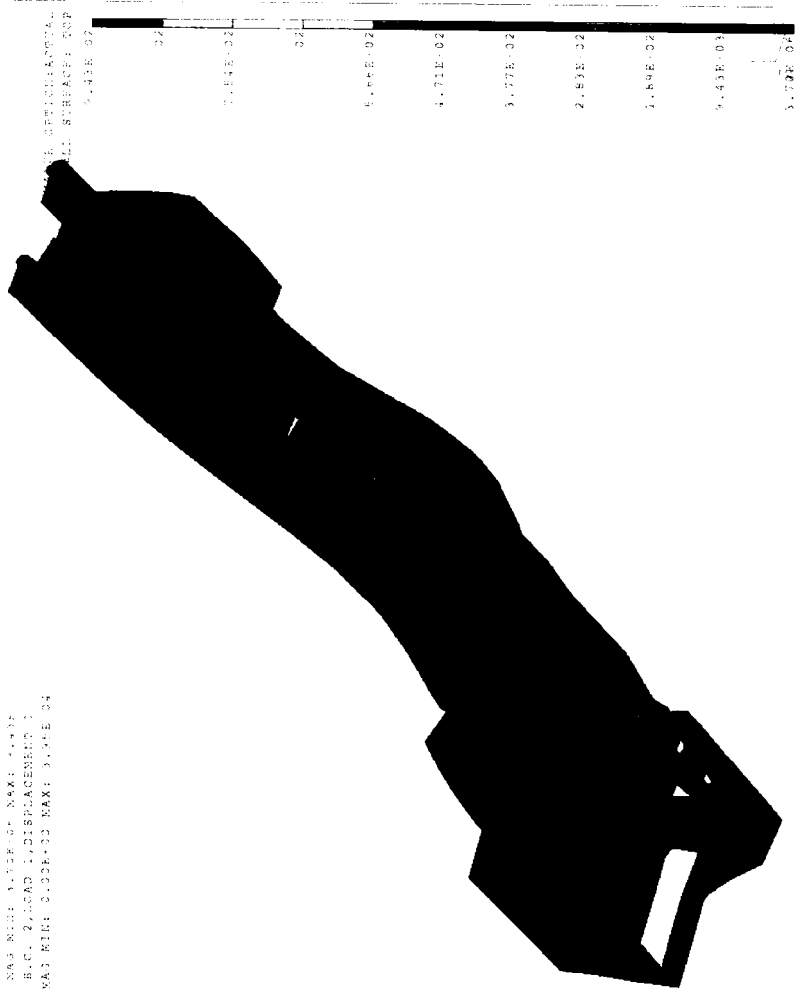

0.44E+02
0.22E+02
0.44E+02
0.22E+02
0.44E+02
0.22E+02
0.44E+02
0.22E+02
0.44E+02
0.22E+02
0.44E+02
0.22E+02

/*****/11/28/1981

RESULTS: 1. B.C. 2. LOAD 1. STRESS 2.
STRESS V.C. MIN: 5.71E+04 MAX: 4.12E+05
DISPLAC: 1. B.C. 2. LOAD 1. DISPLACEMENTS:
DISPLACEMENT V.C. MIN: 0.00E+00 MAX: 2.18E-04
FRAME OF REF: PAE

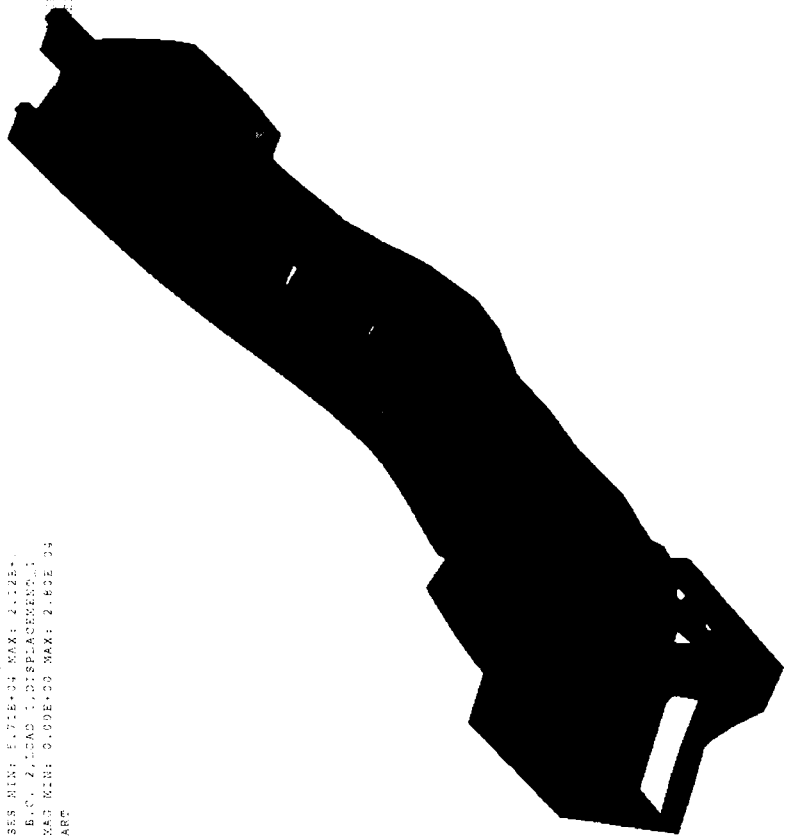

7.32E+07
1.43E+07
1.32E+07
1.48E+07
1.27E+07
1.06E+07
8.50E+06
6.39E+06
4.28E+06
2.17E+06
5.77E+04

/users/lizan/nickx.me:

RESULTS: 2. B.C. 2.LOAD 1,STRESS.2
SFRESS: MAX PRIN MIN: 1.05E+07 MAX: 2.31E+07
DEFORMATION: 1. B.C. 2.LOAD 1,DISPLACEMENT.1
DISPLACEMENT: MAX MIN: 0.00E+00 MAX: 2.60E-04
FRAME OF REF: PART

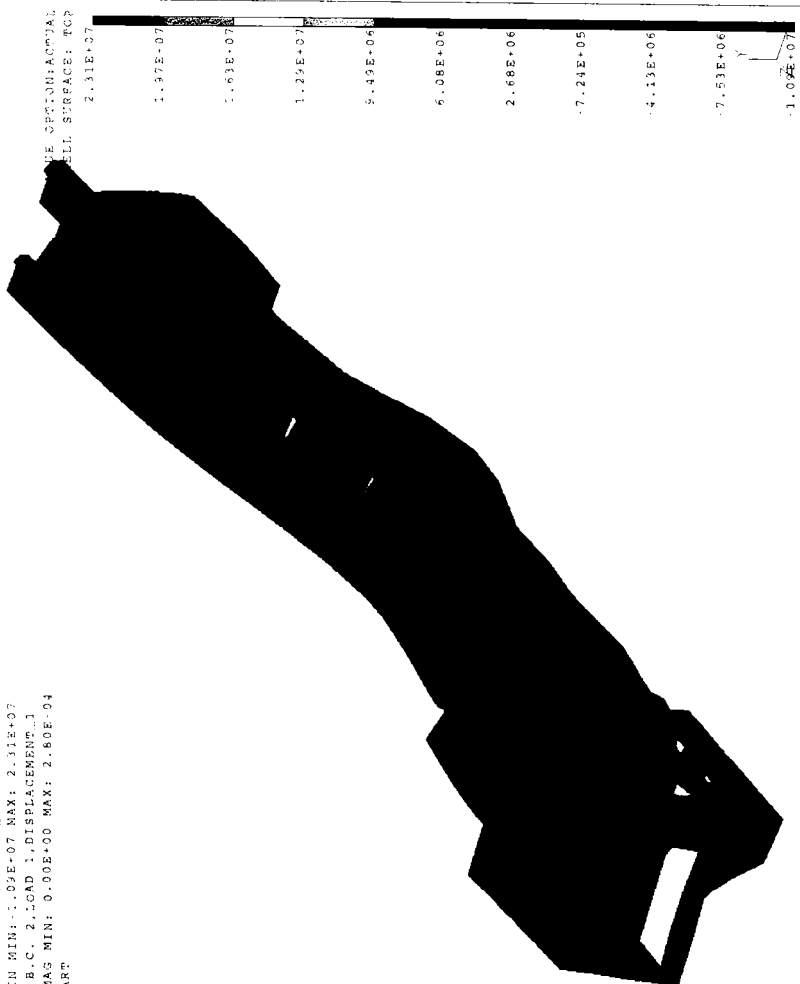

THE SPRT:ON:AC:PA:1
CELL SURFACE: TCP
2.31E+07
1.37E+07
1.63E+07
1.35E+07
5.49E+06
6.06E+06
2.68E+06
-7.24E+05
-4.13E+06
-7.53E+06
-1.04E+07



/sbarf/1256/1256.rst

RESULTS 2 B.C. 2.LOAD 1.PRESS 2
STRESS MAX SHEAR MIN 3.2E+04 MAX: 1.17E+07
DEFORMATION 1 B.C. 2.LOAD 1.DISP/ITERATION
DISPLACEMENT MAX MIN 0.03E+00 MAX: 2.56E-04
PAGE 02 REF: PART

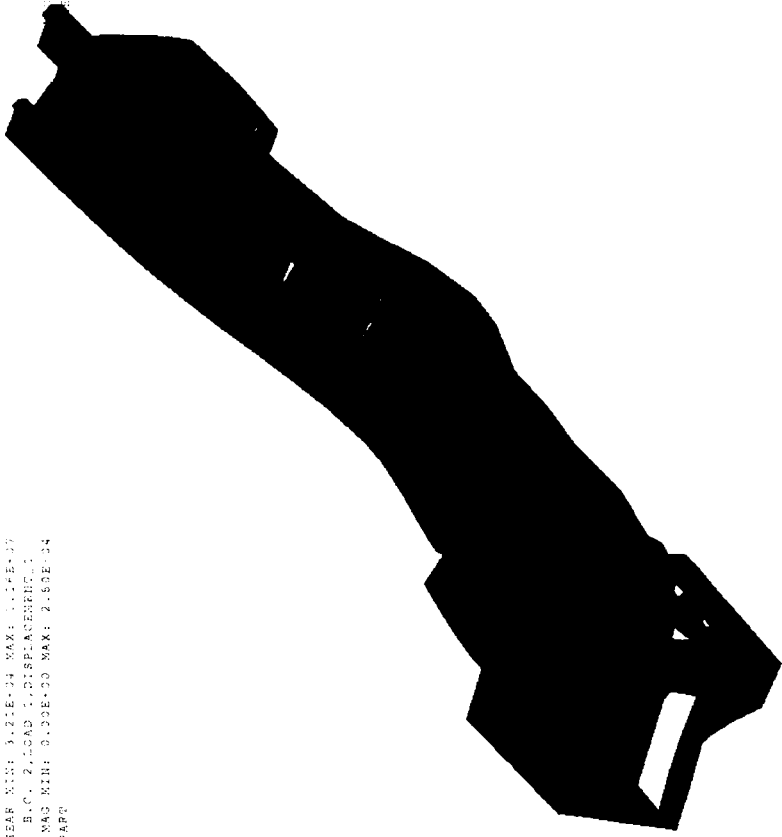

1.17E+07
1.07E+07
9.98E+06
8.93E+06
7.92E+06
6.94E+06
5.98E+06
5.04E+06
4.15E+06
3.29E+06
2.45E+06
1.68E+06
9.22E+05

CALCUL STATIC BATIU VARIANTA CU PICIOR

TENSIUNI VON MISES

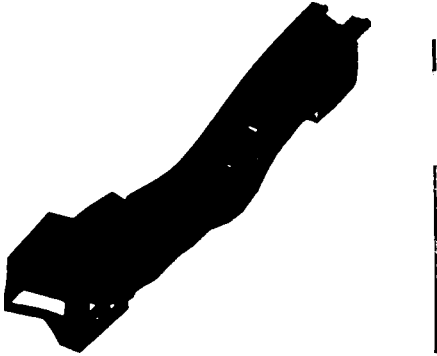

TENSIUNI PRINCIPALE

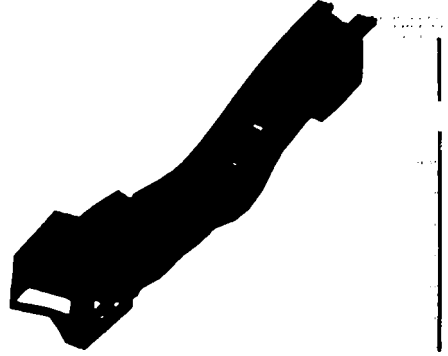
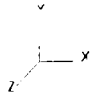

TENSIUNI TANGENTIALE

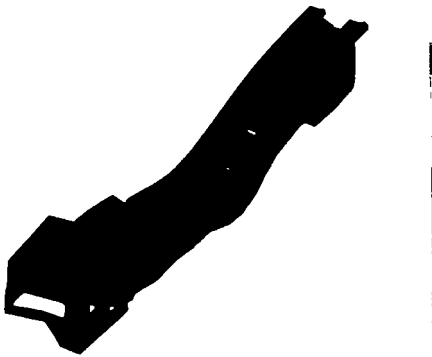

ENERGIE DE DEFORMATIE

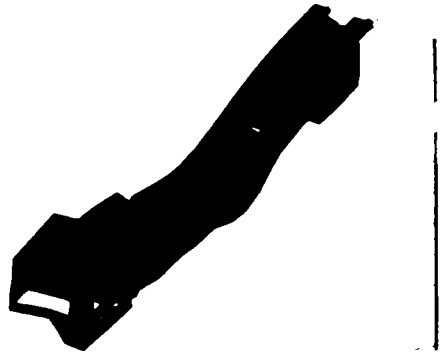



1.33E+04

1.33E+04

VALUE OPTIC/ACTUAL
CELL SURFACE: TOP

3.84E+07
3.28E+07
2.77E+07
2.17E+07
1.61E+07
1.05E+07
4.95E+06
6.19E+05
6.19E+06
1.18E+07
1.7E+07



Y

1.1E-04

Net
ter

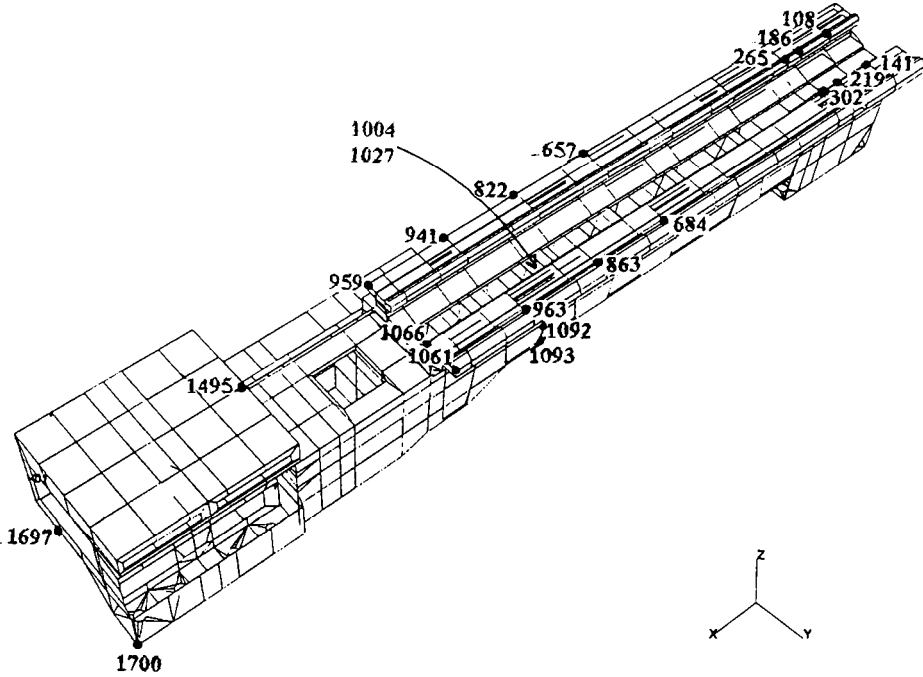

CALCUL DINAMIC -cu ajutorul MEF
Sectiunile si punctele de calcul de pe batii

617.595/6
 180 C BUPT

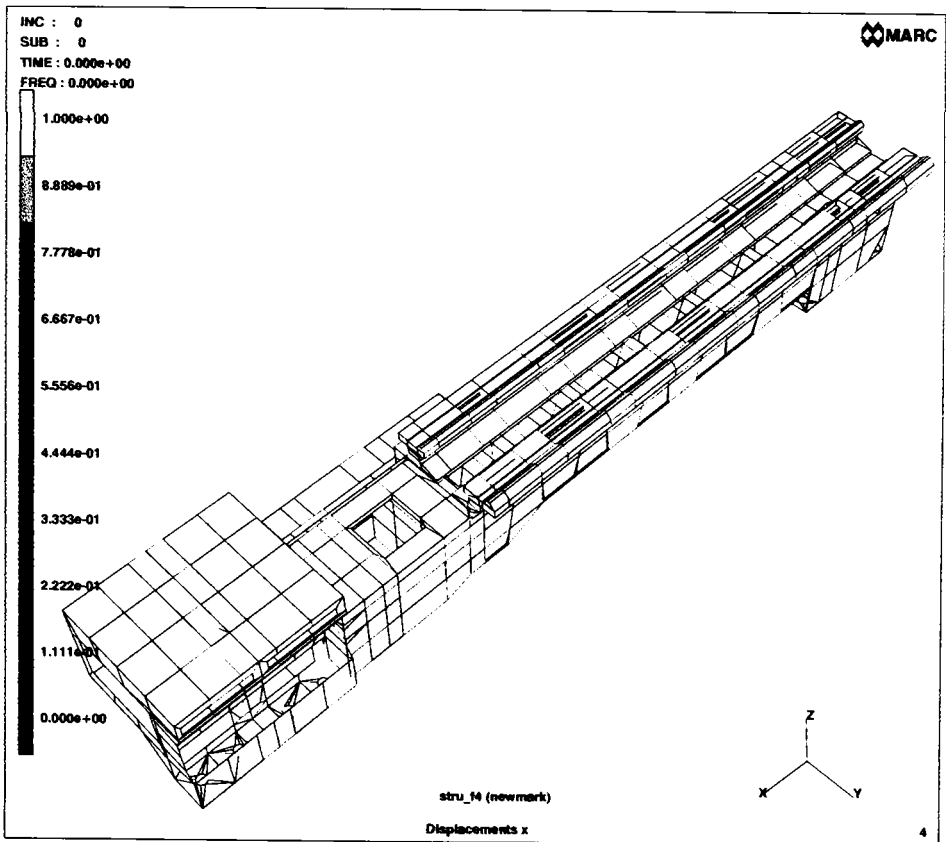

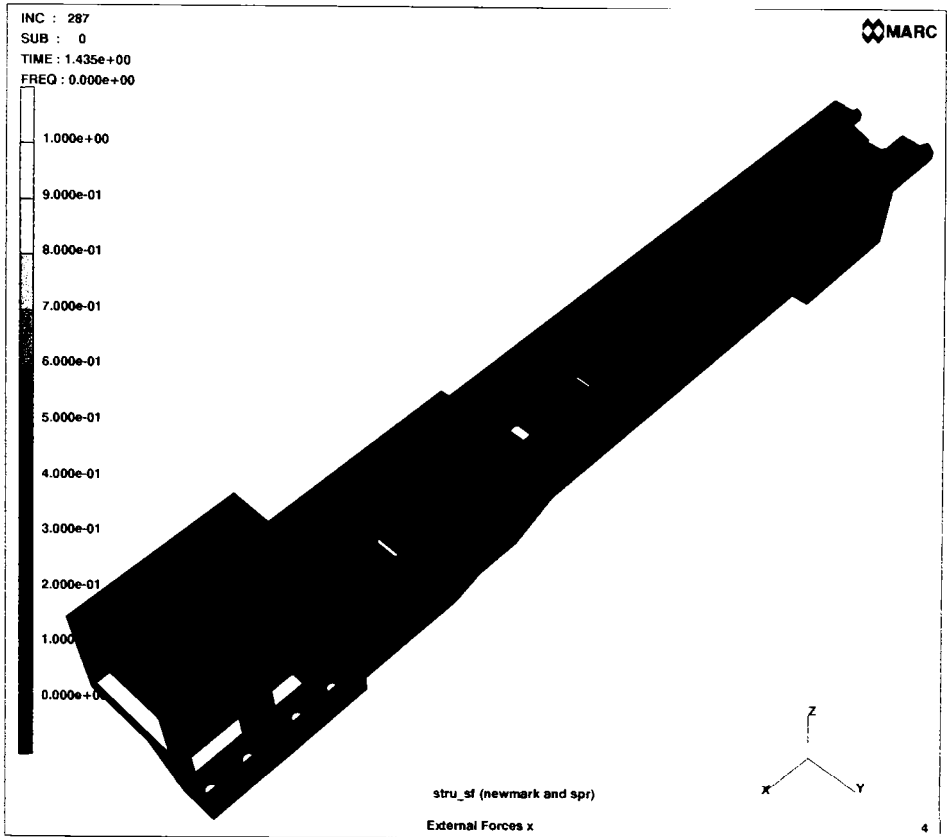

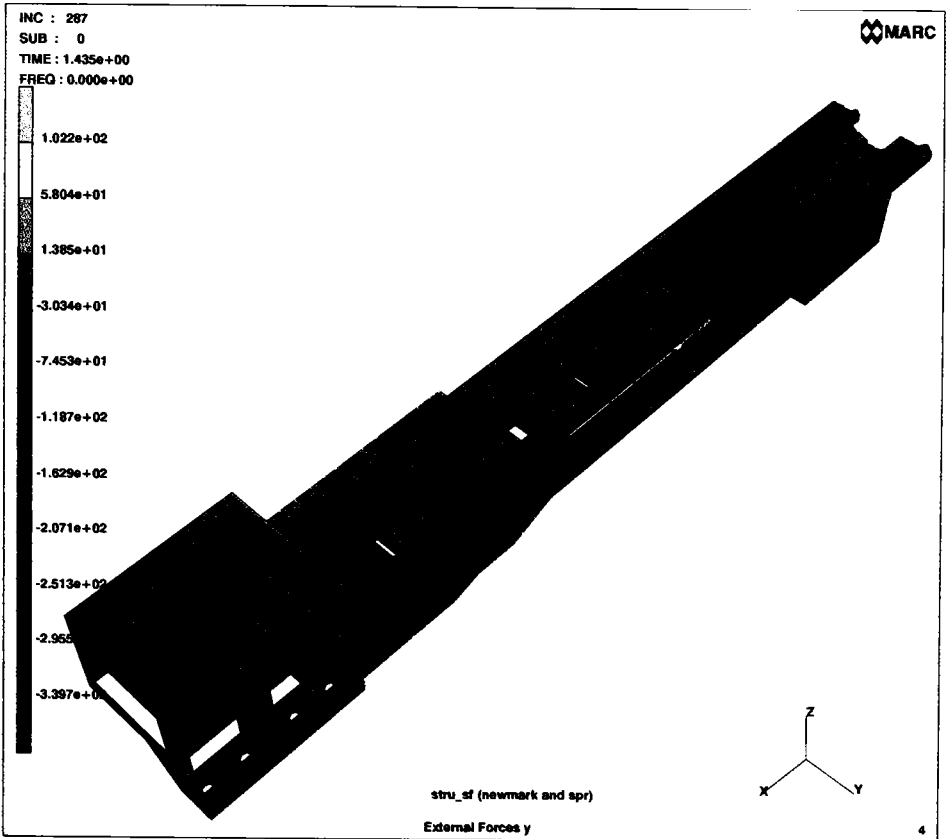

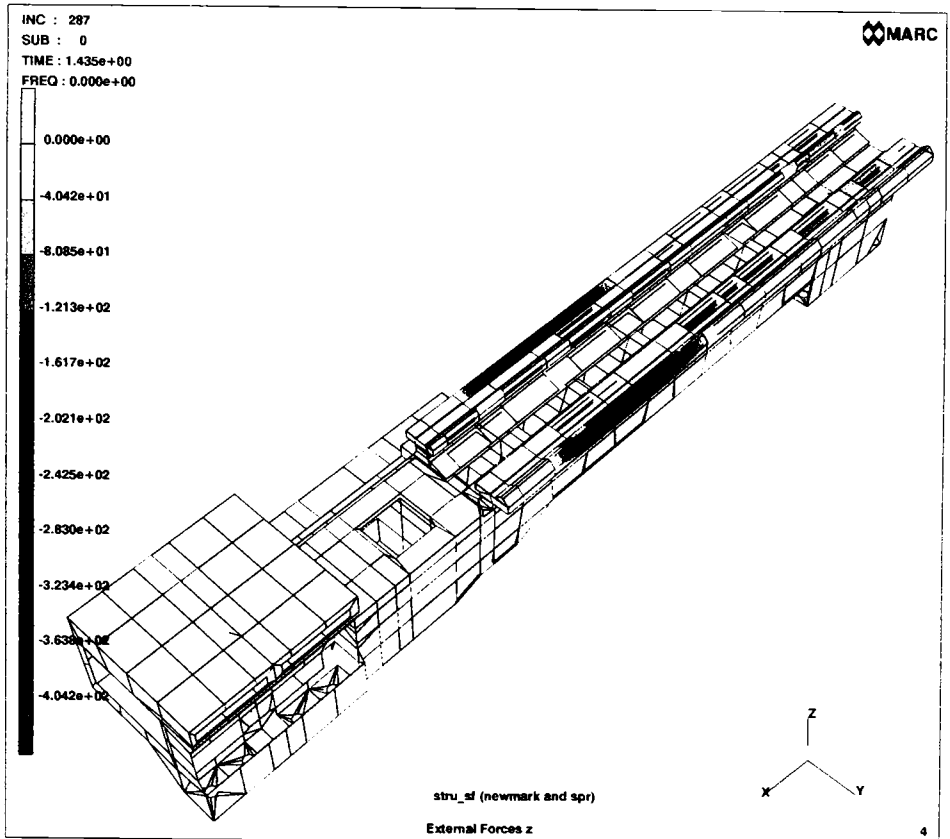

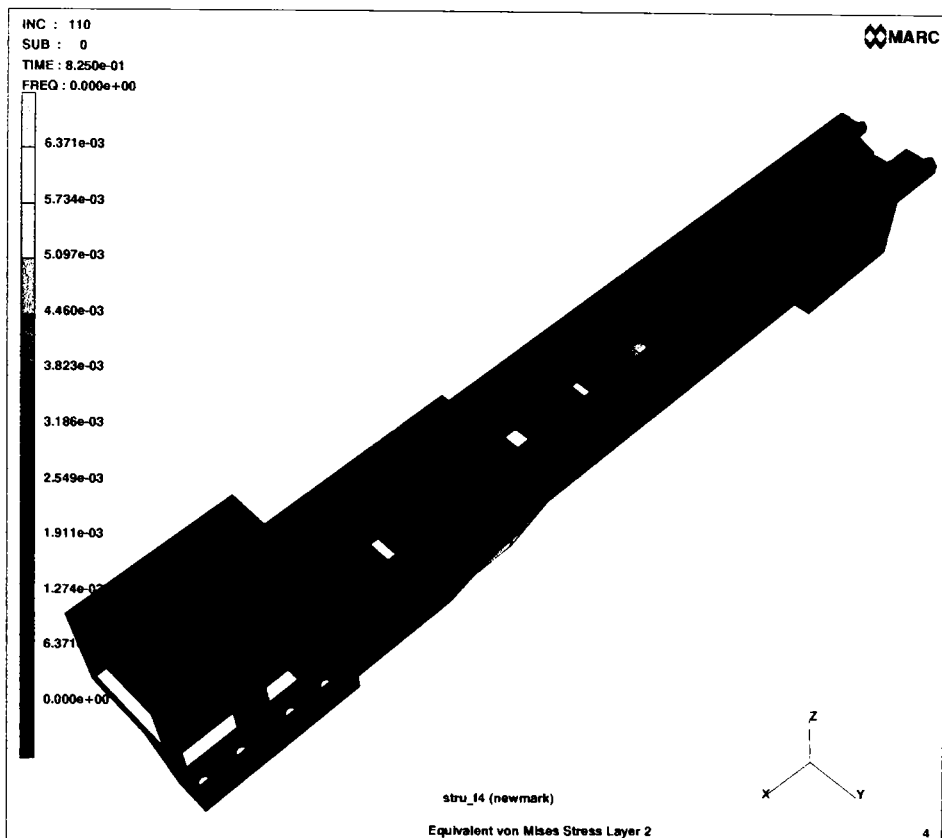

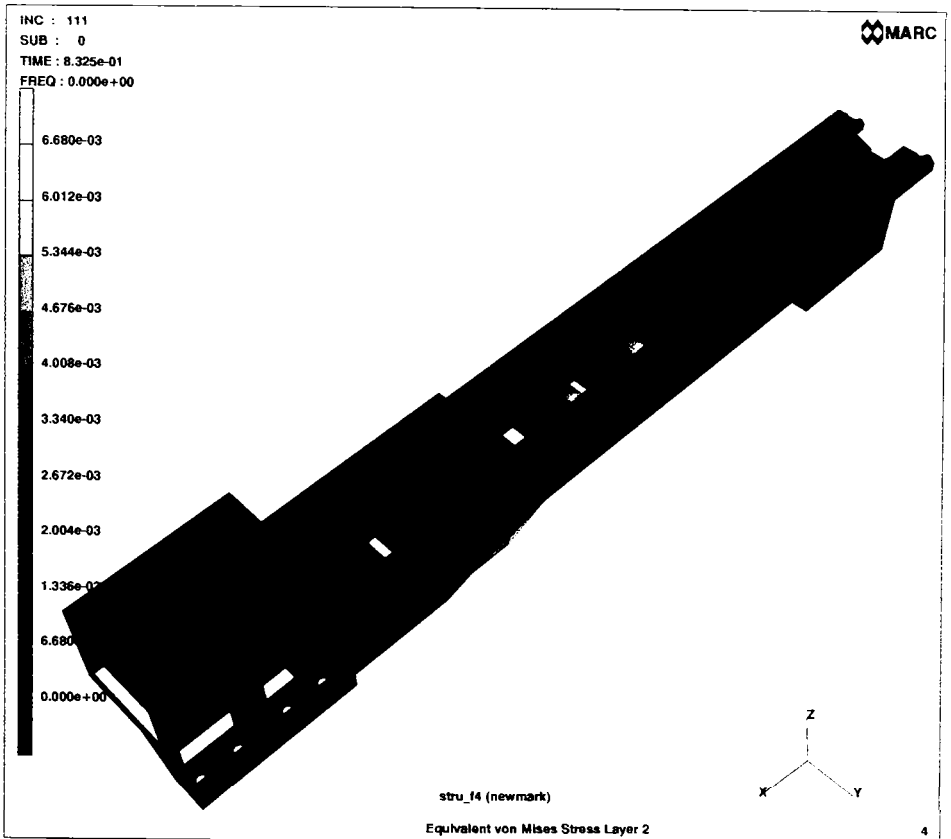

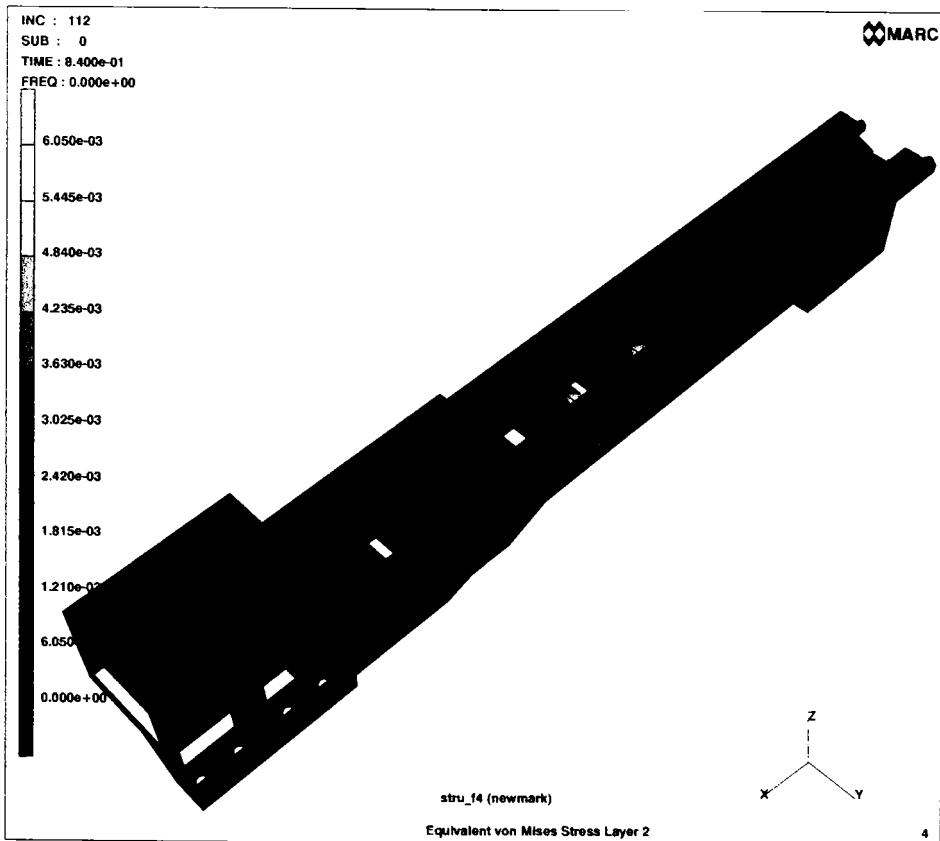

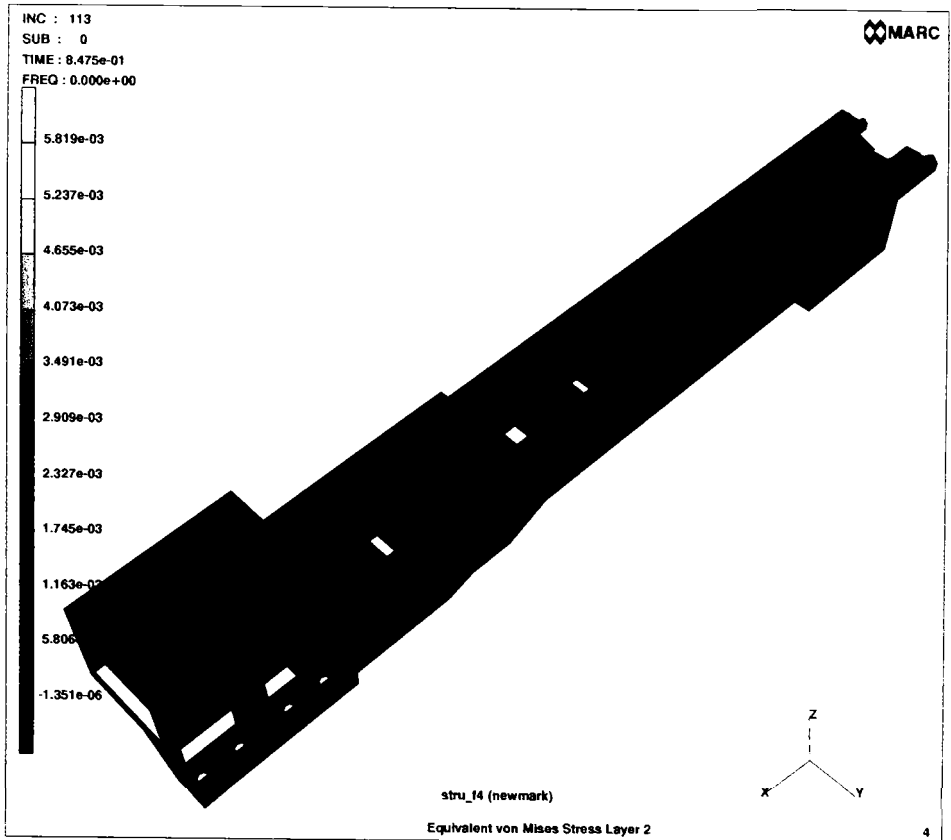

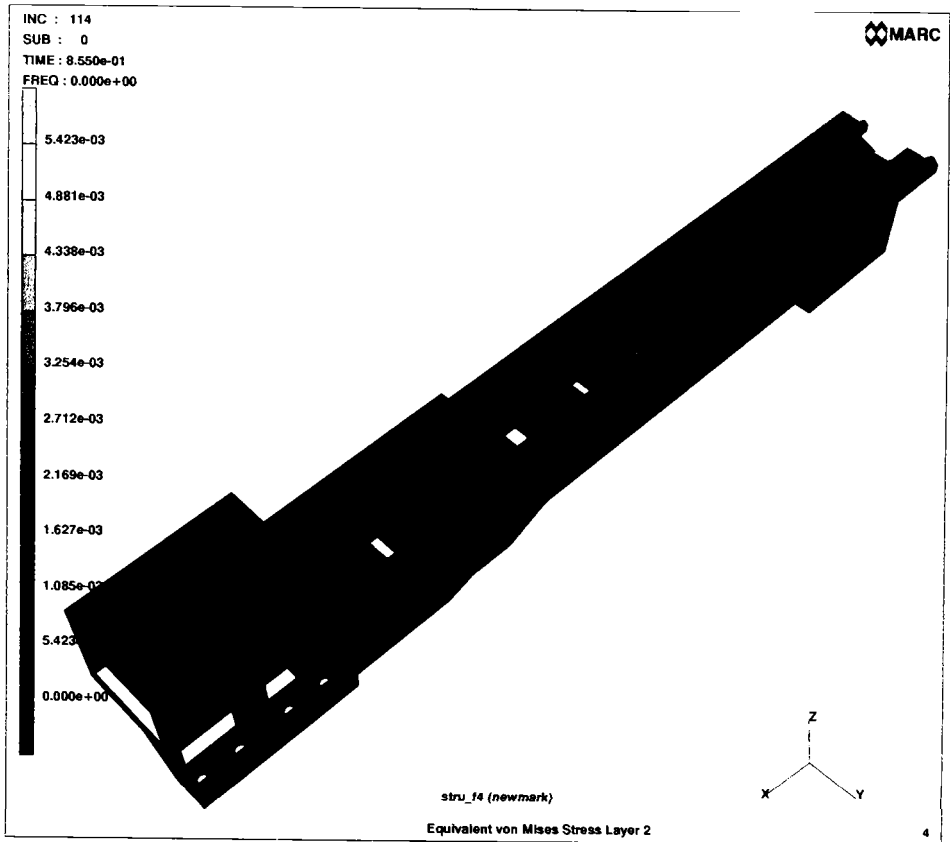

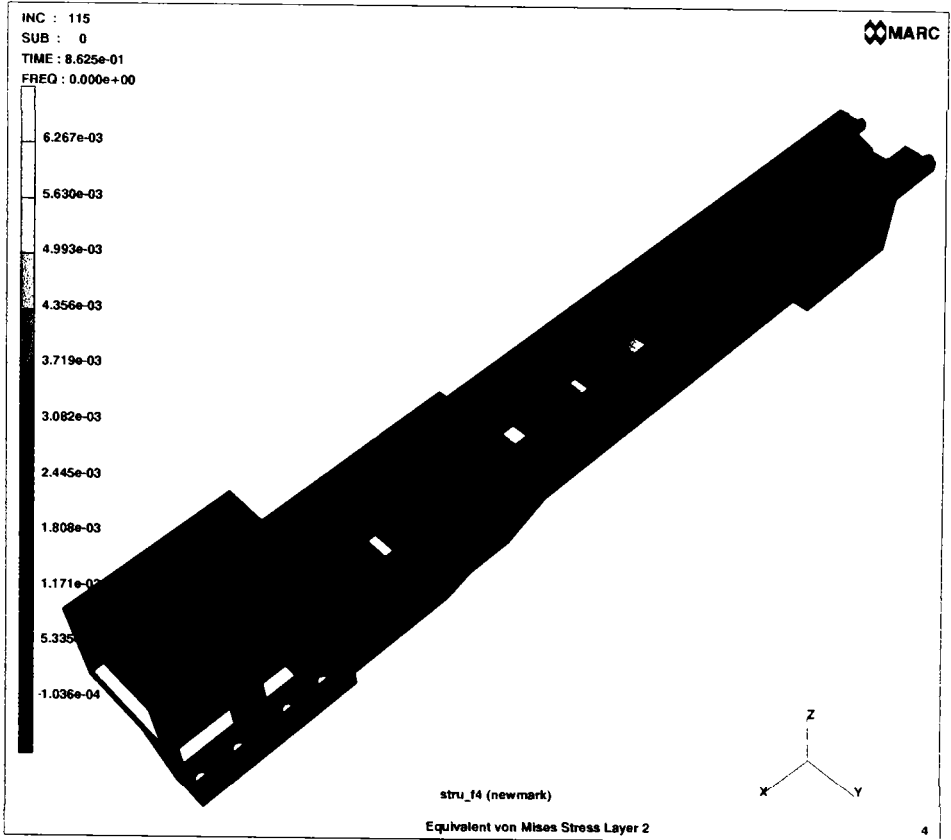

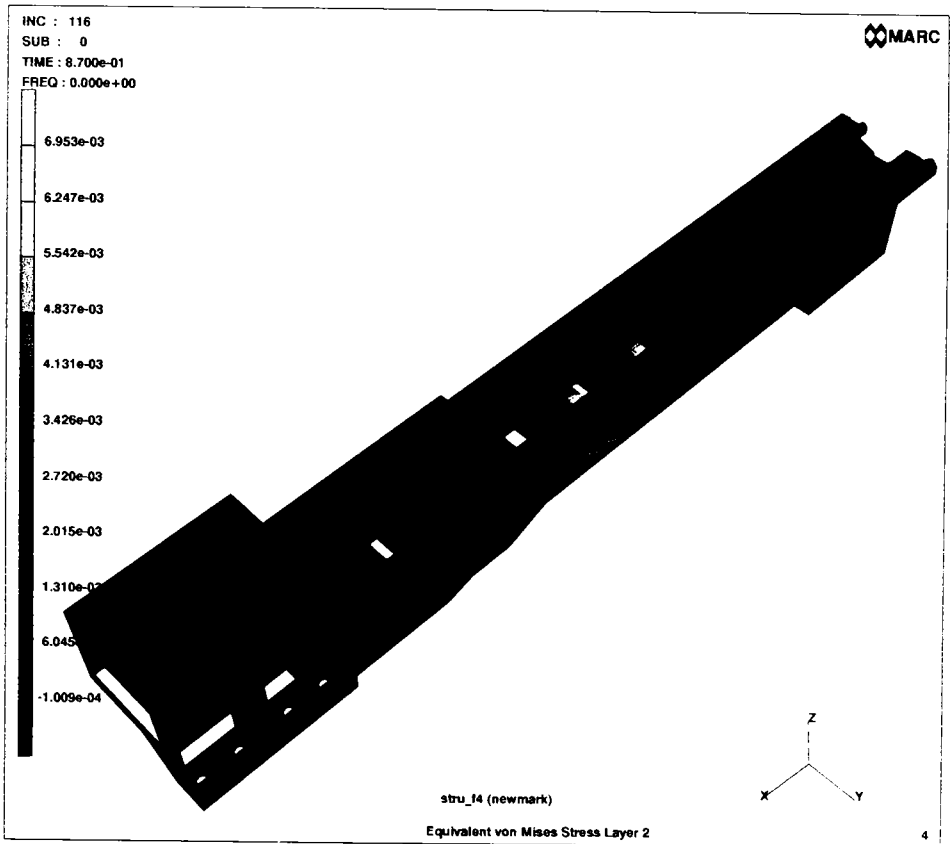

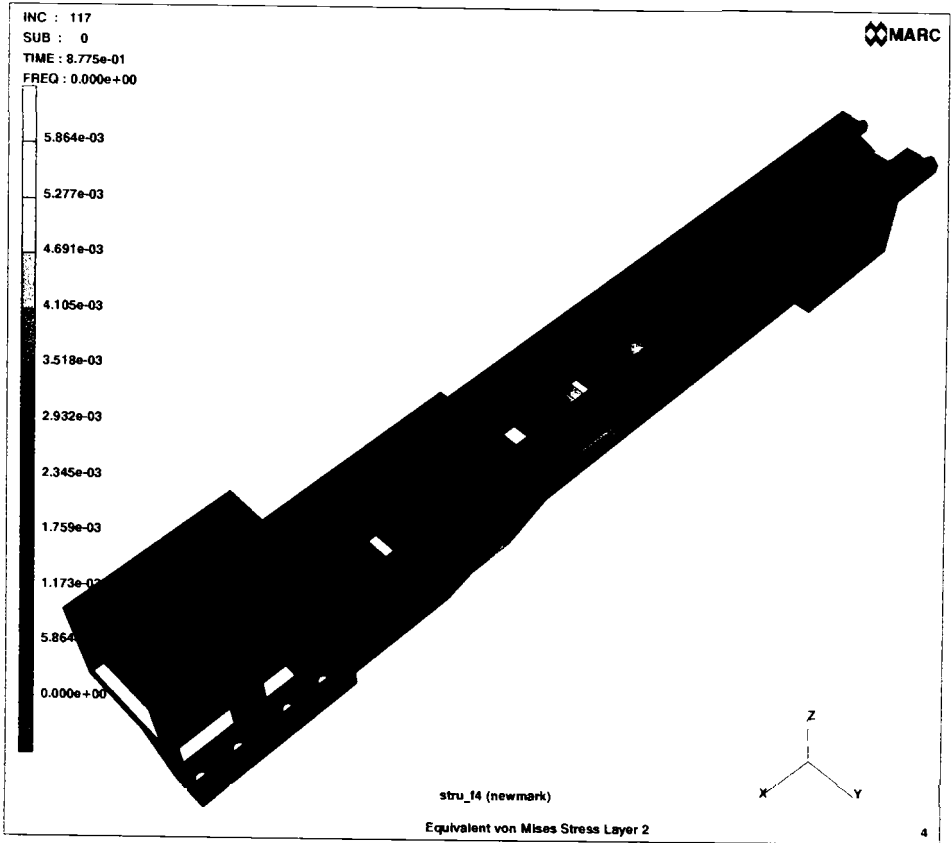

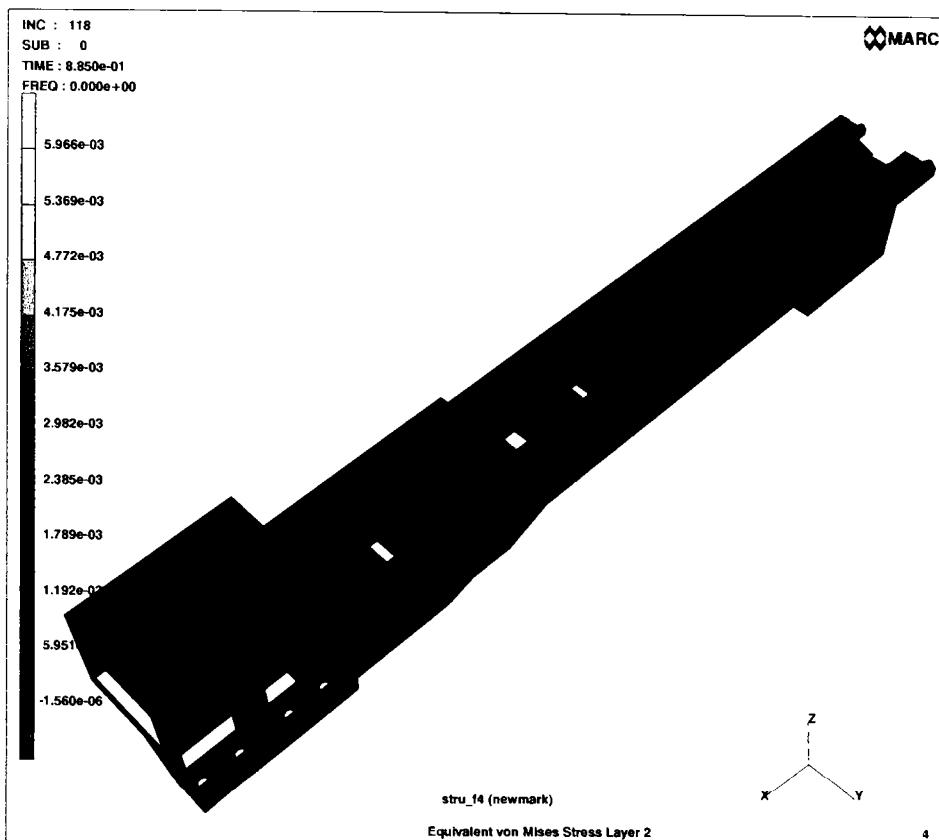

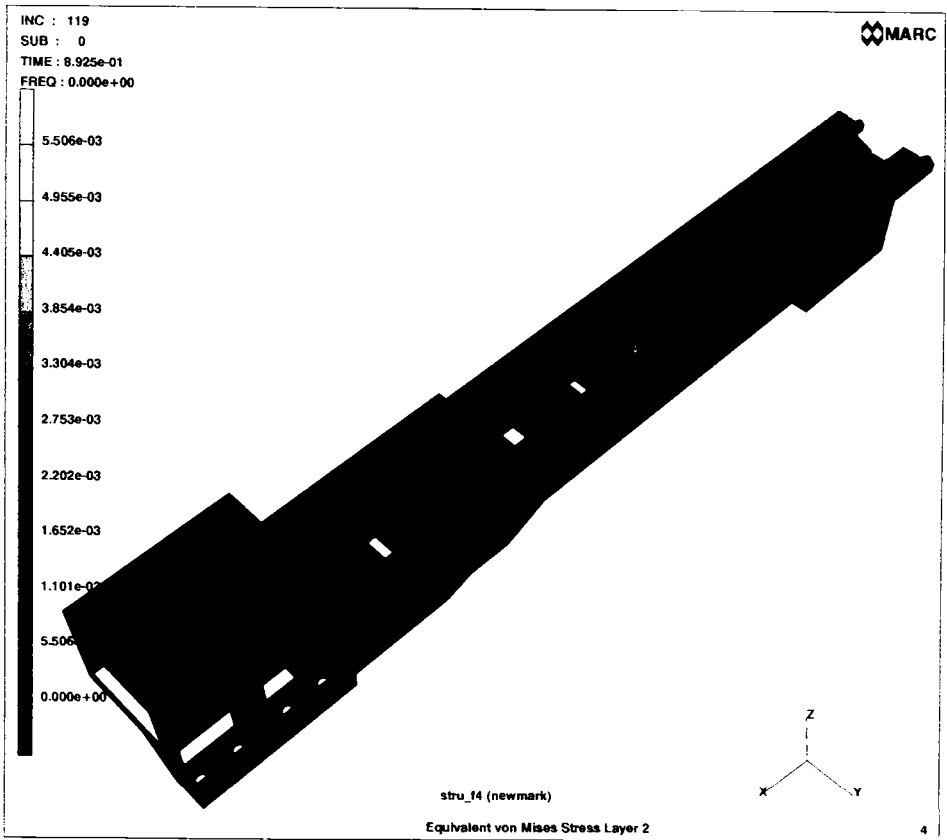

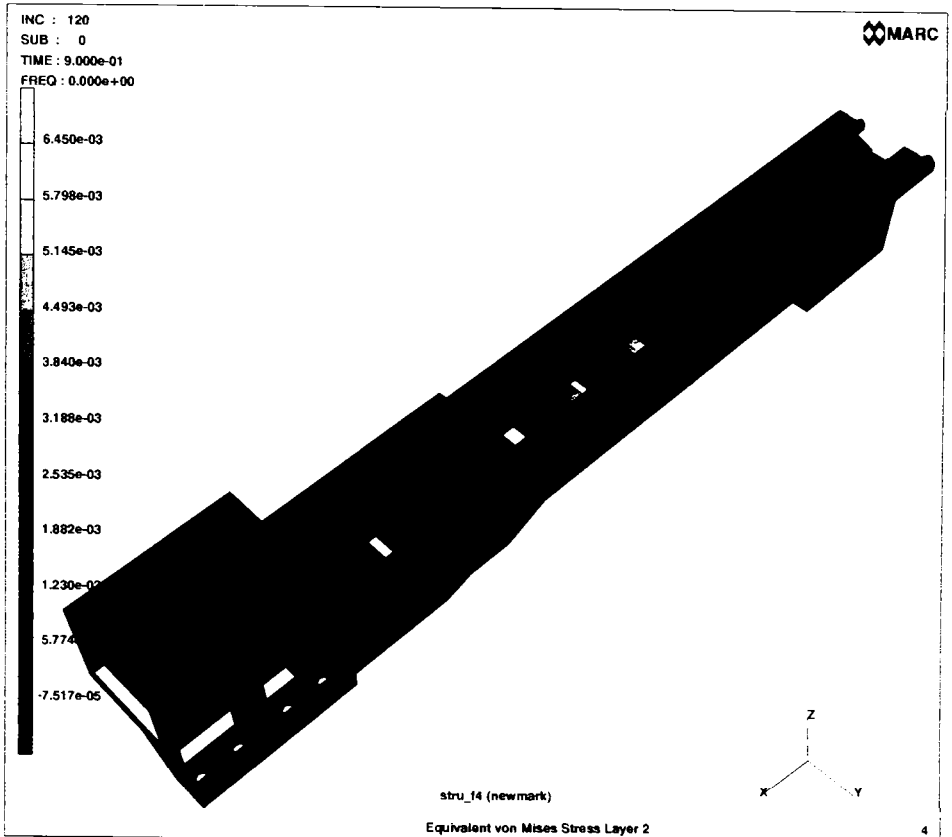

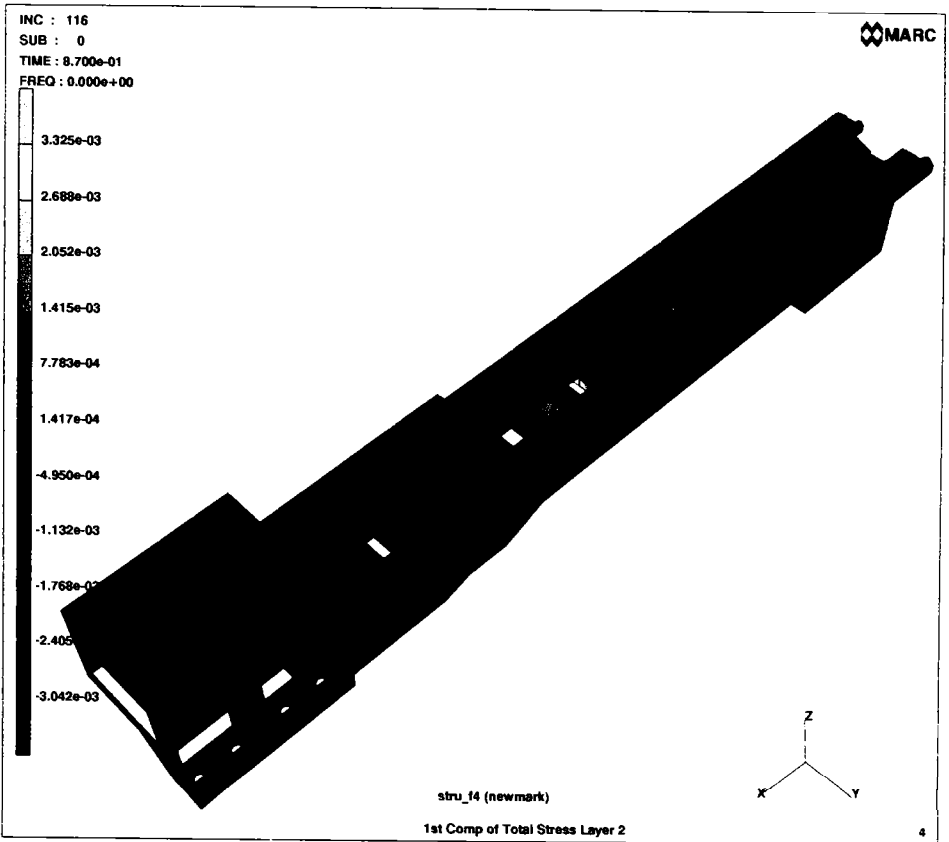

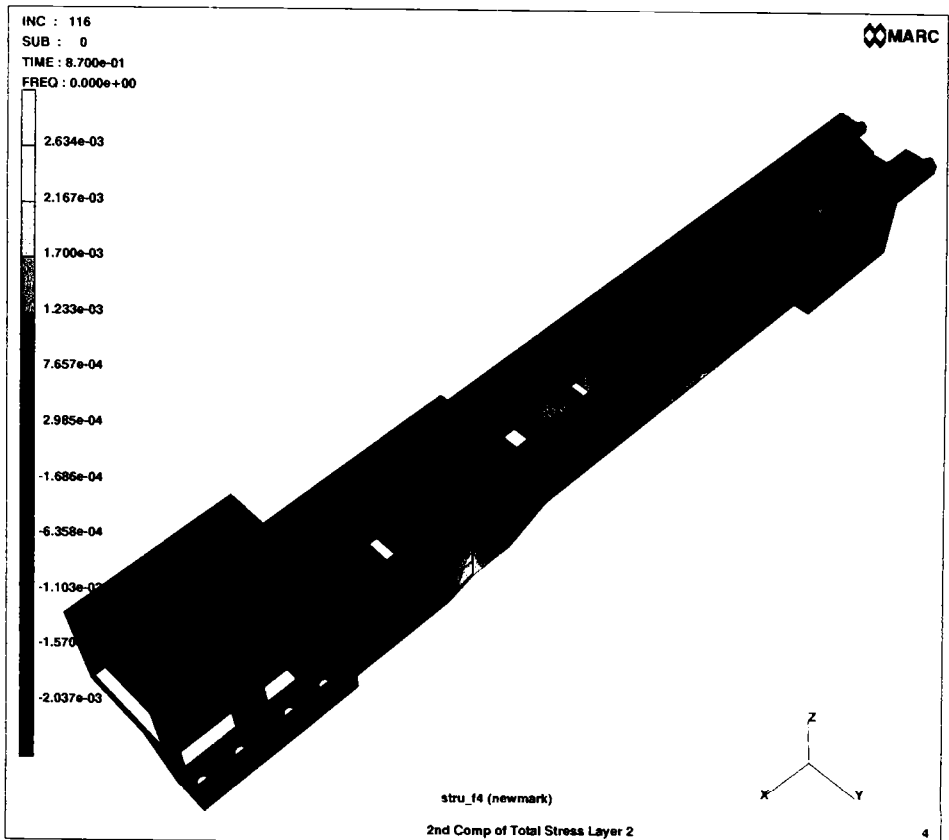

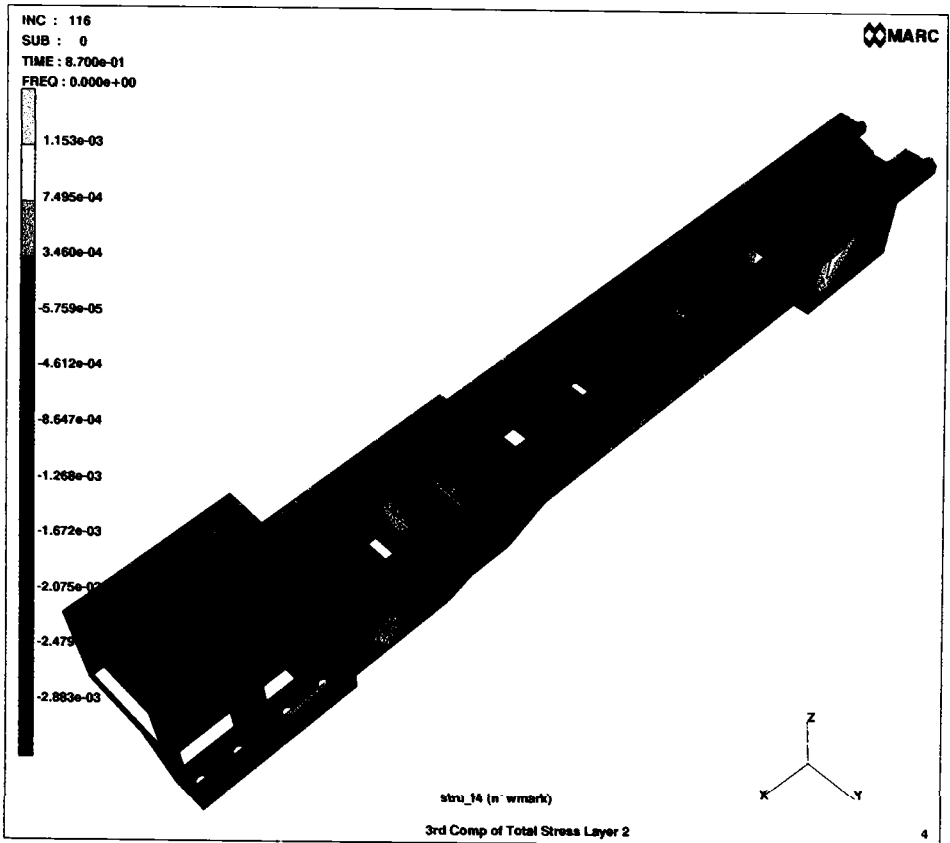

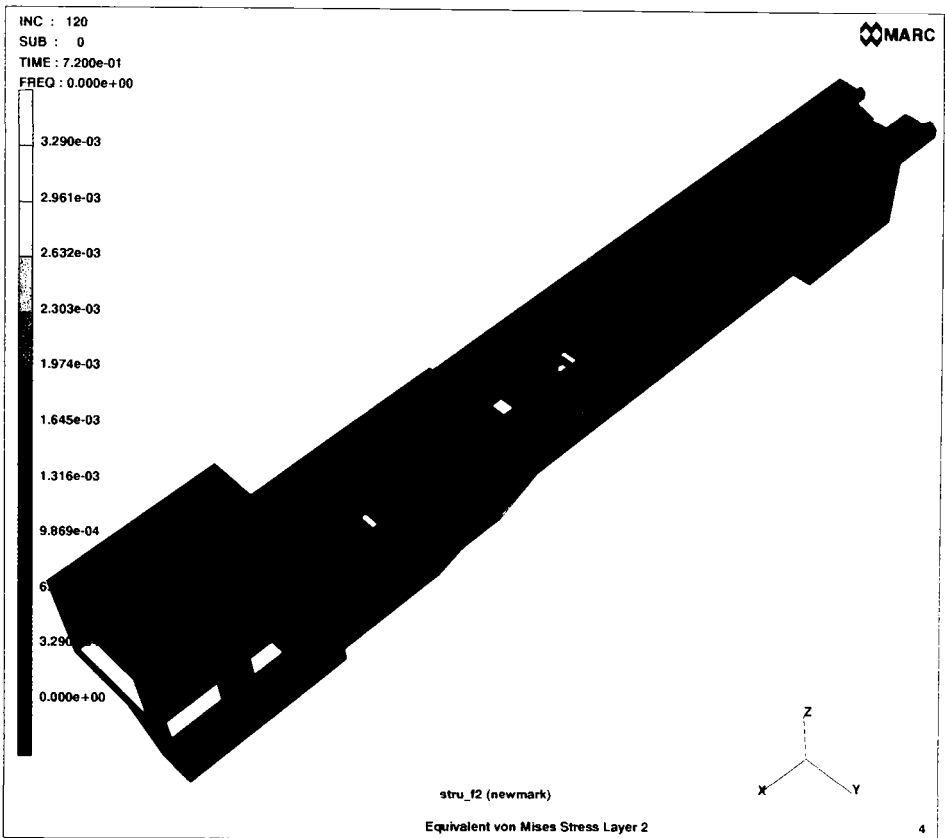

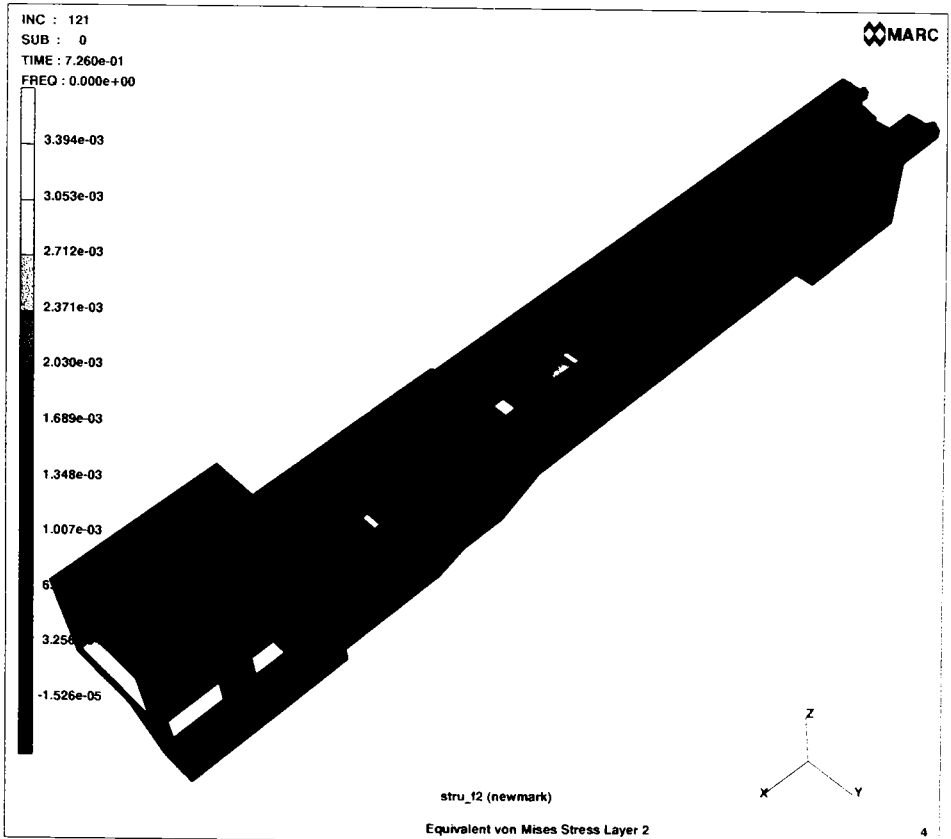

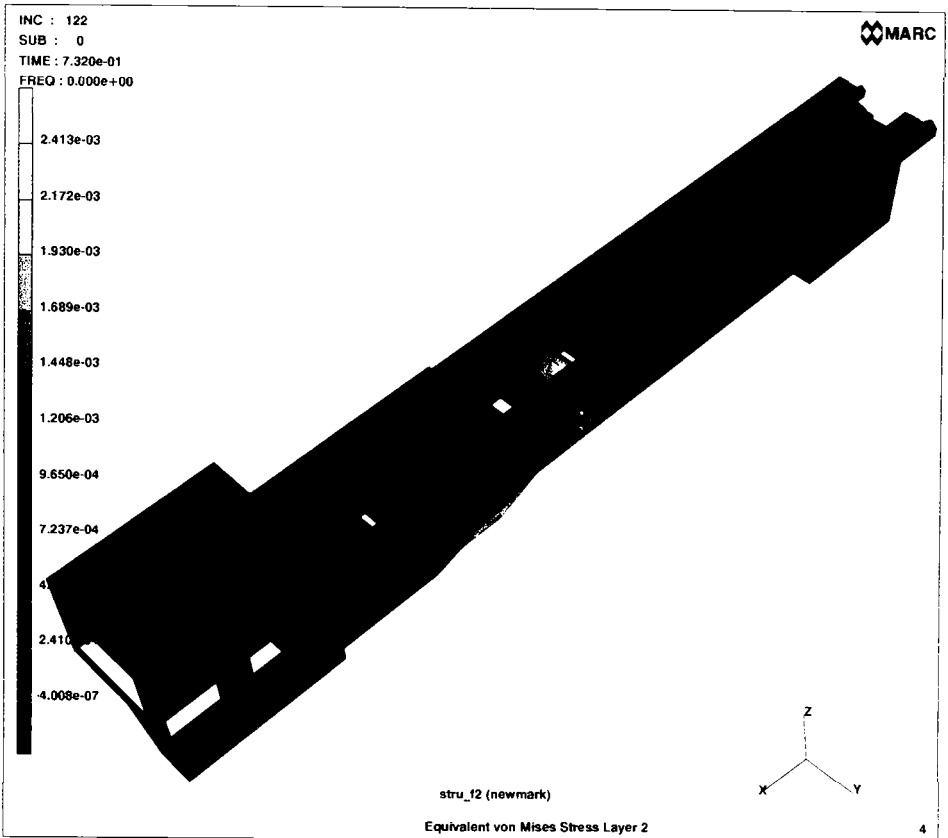

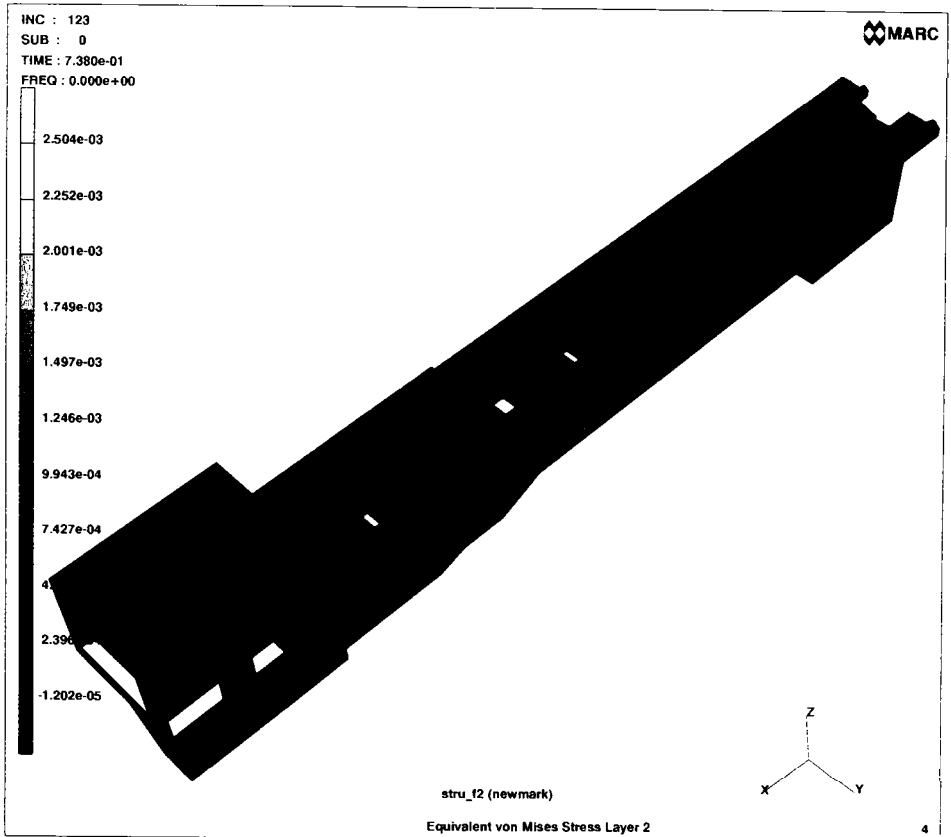

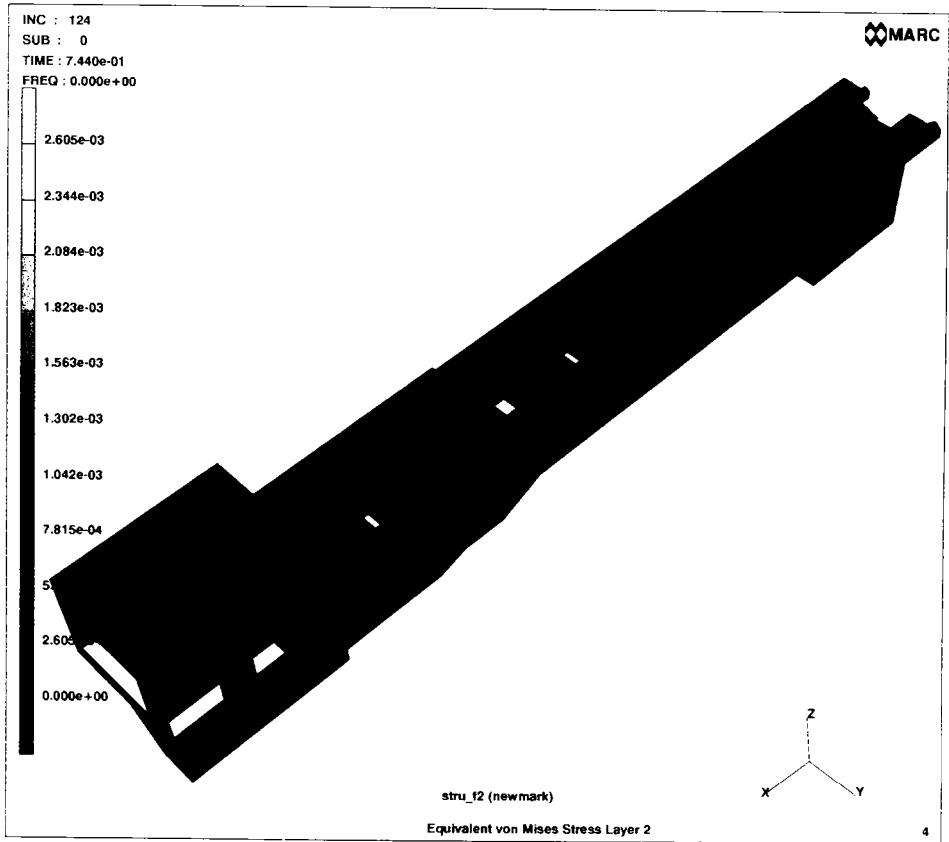

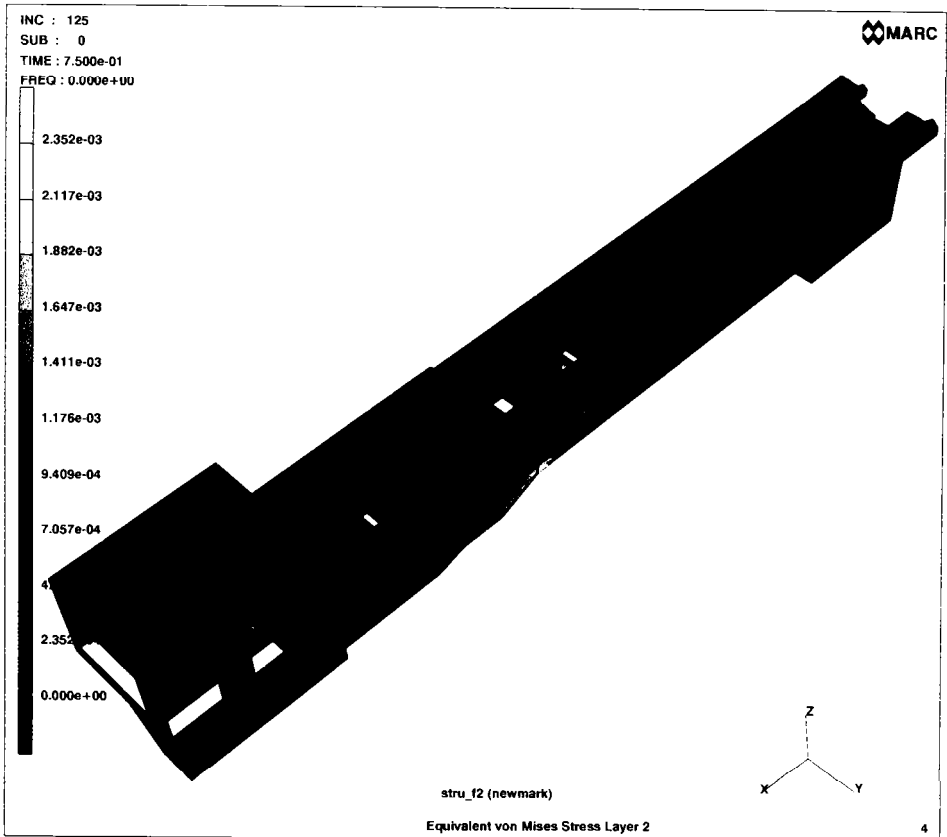

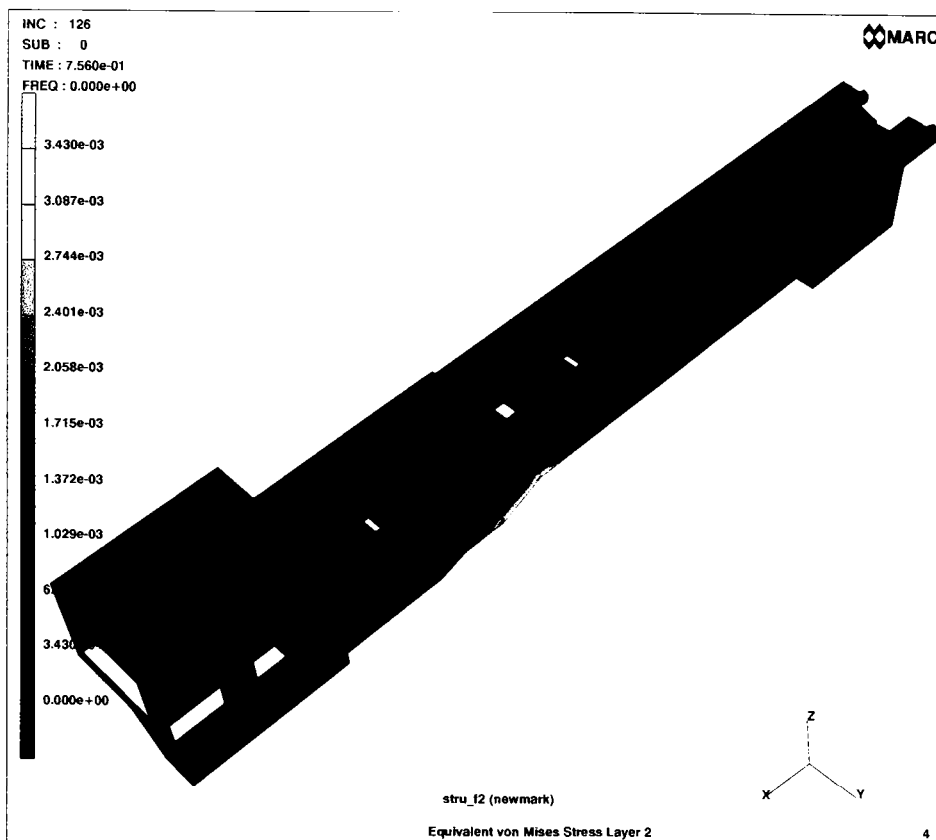

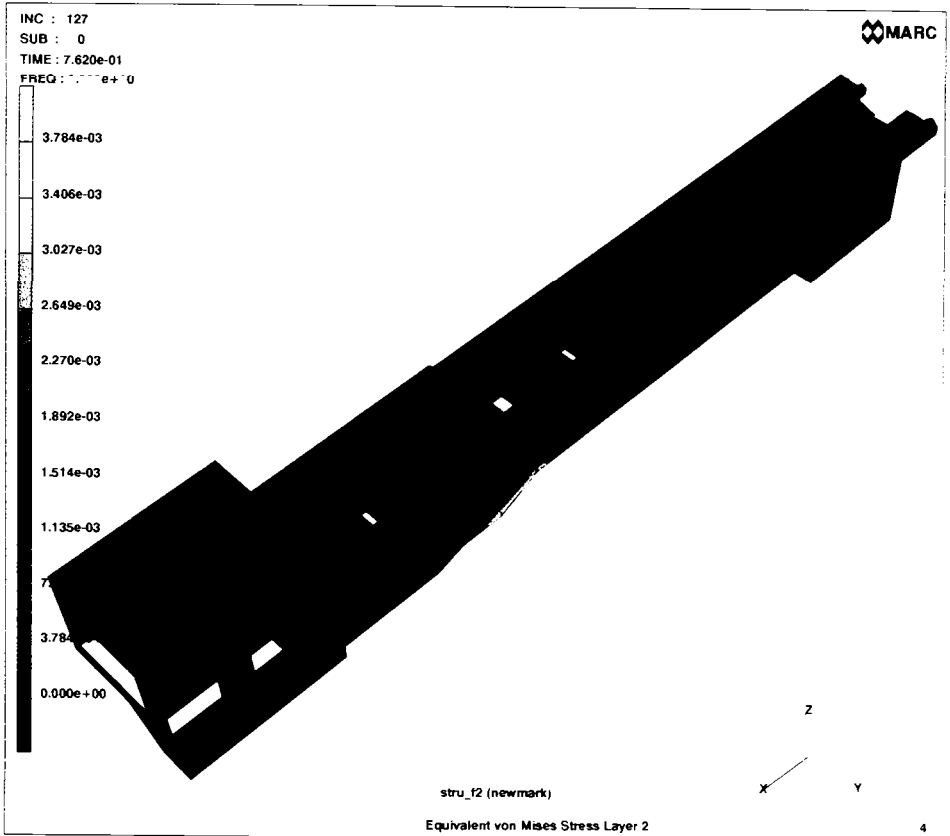

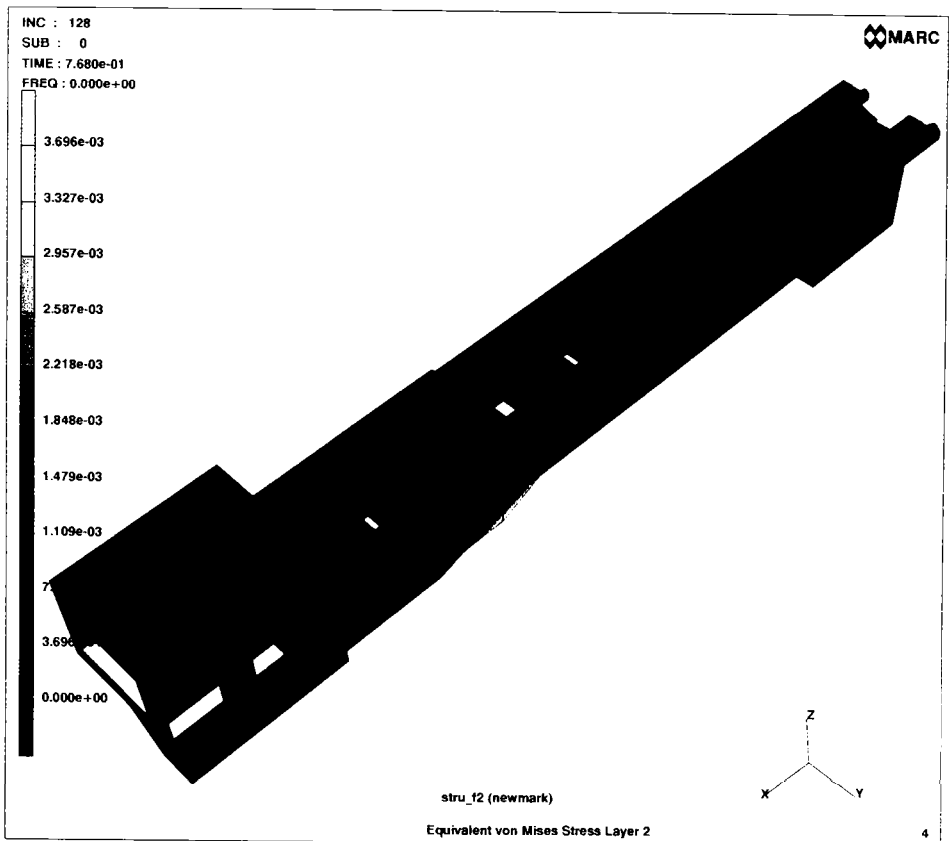

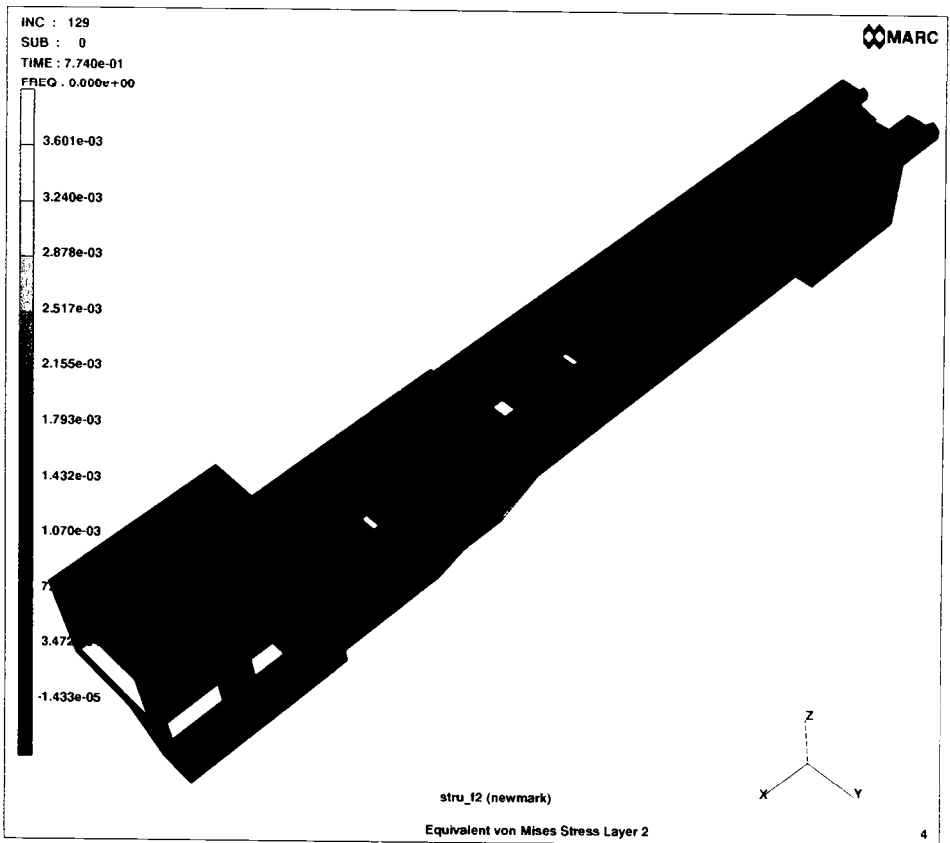

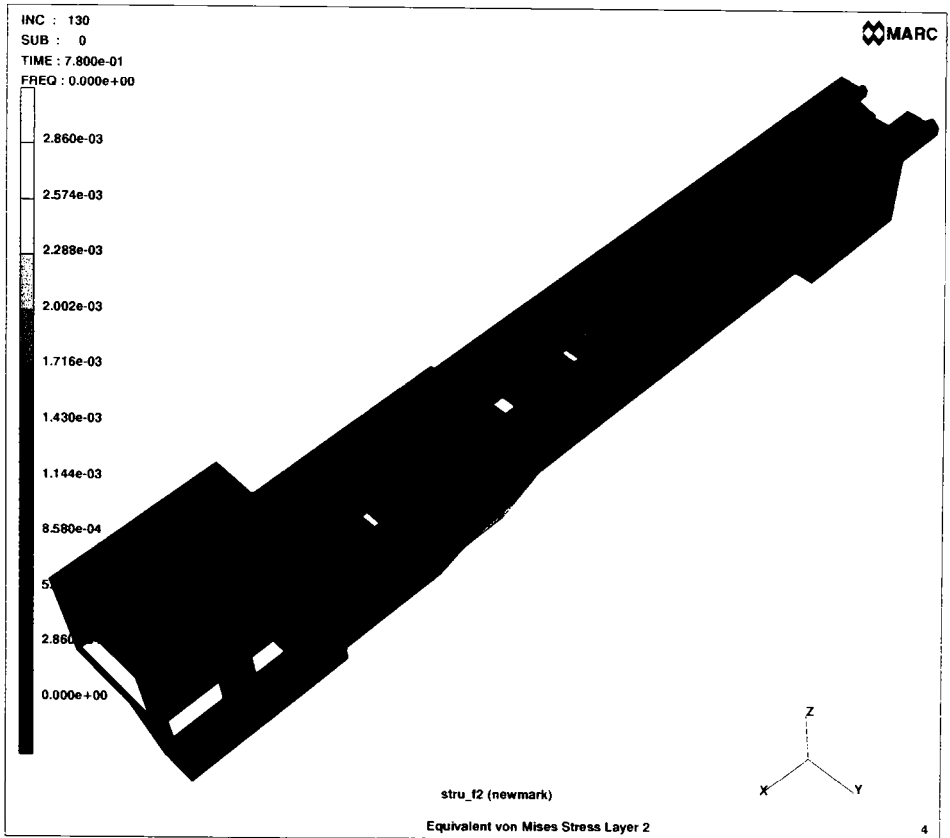

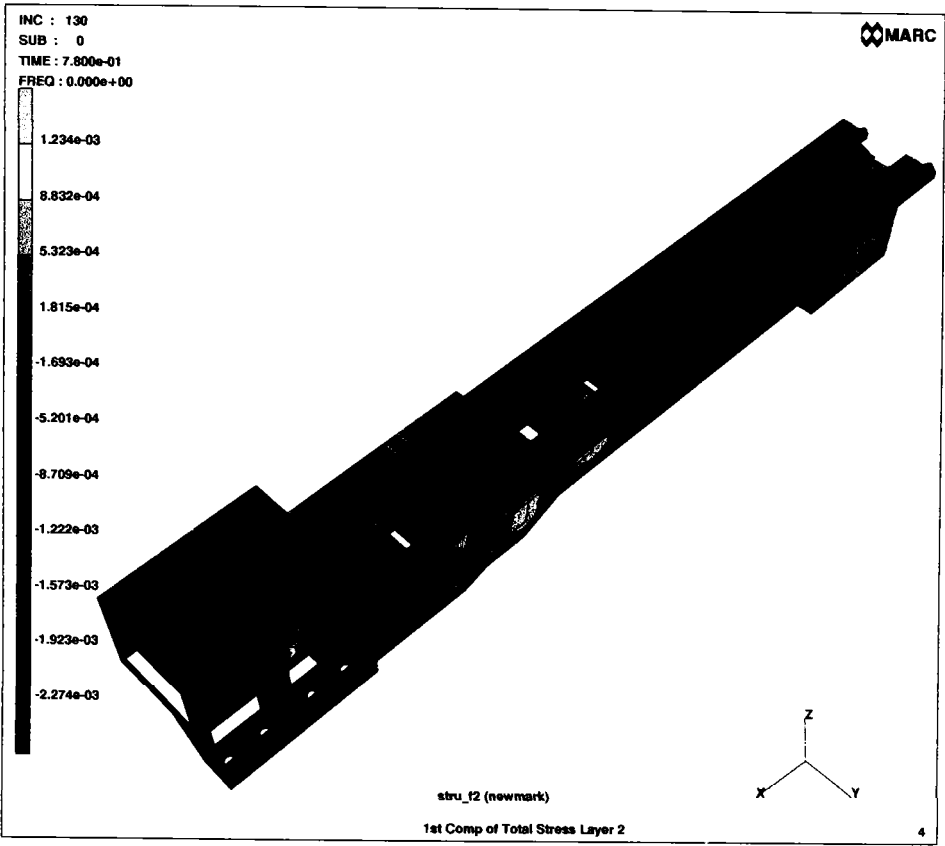

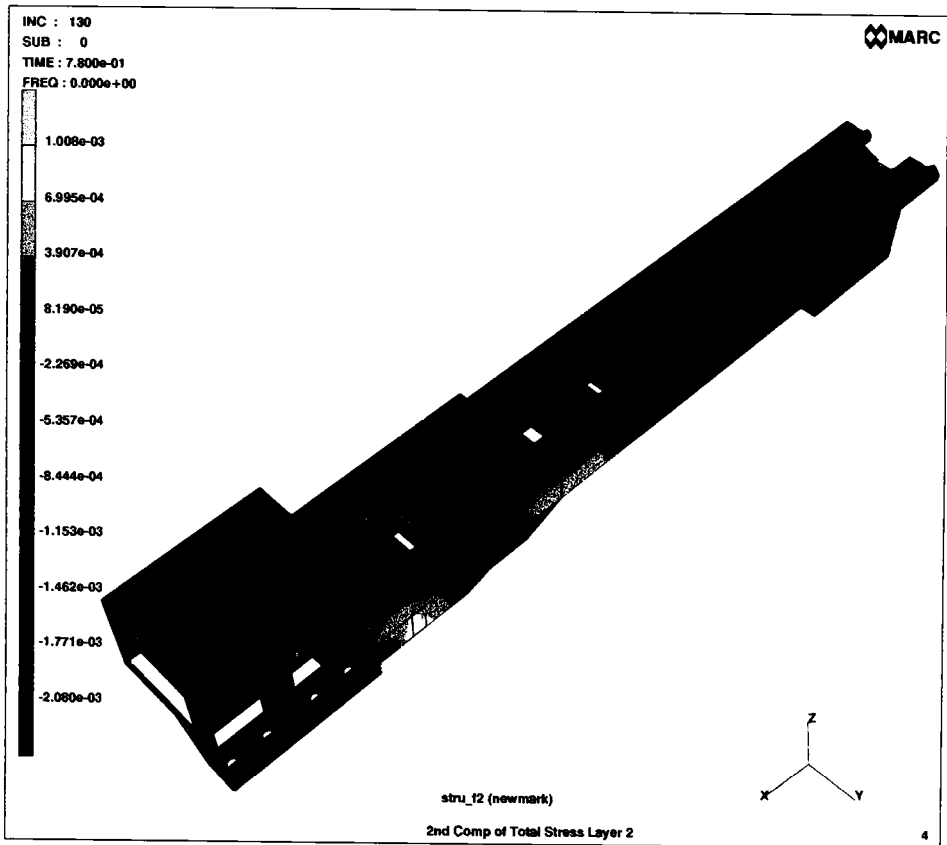

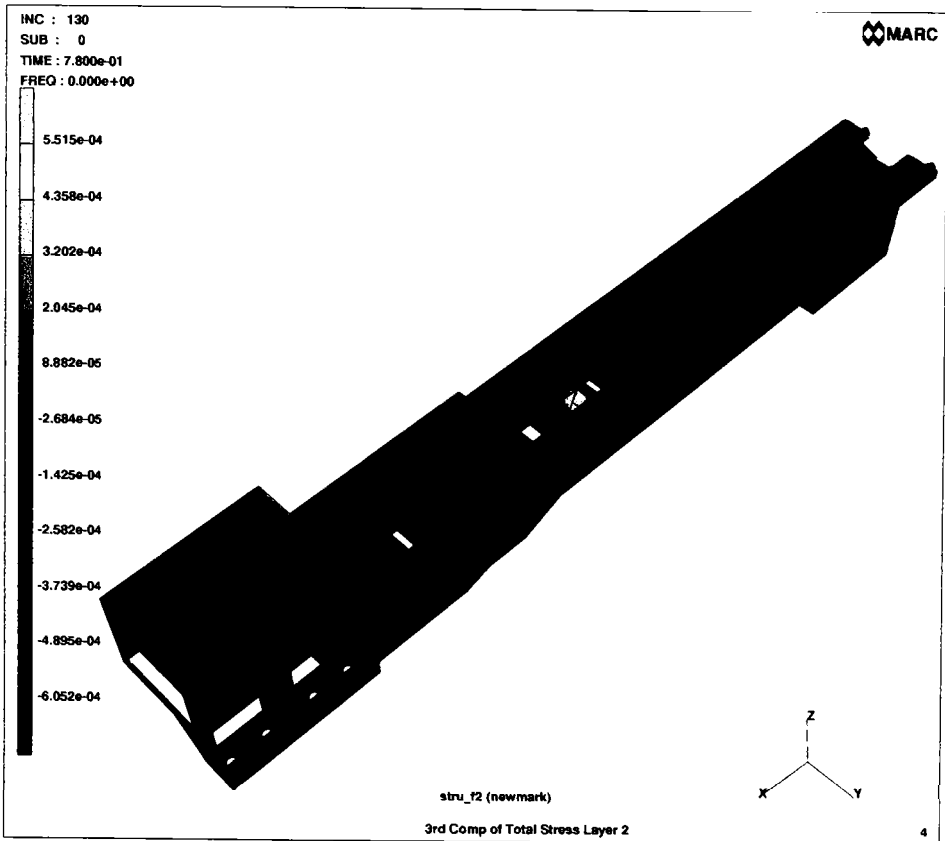

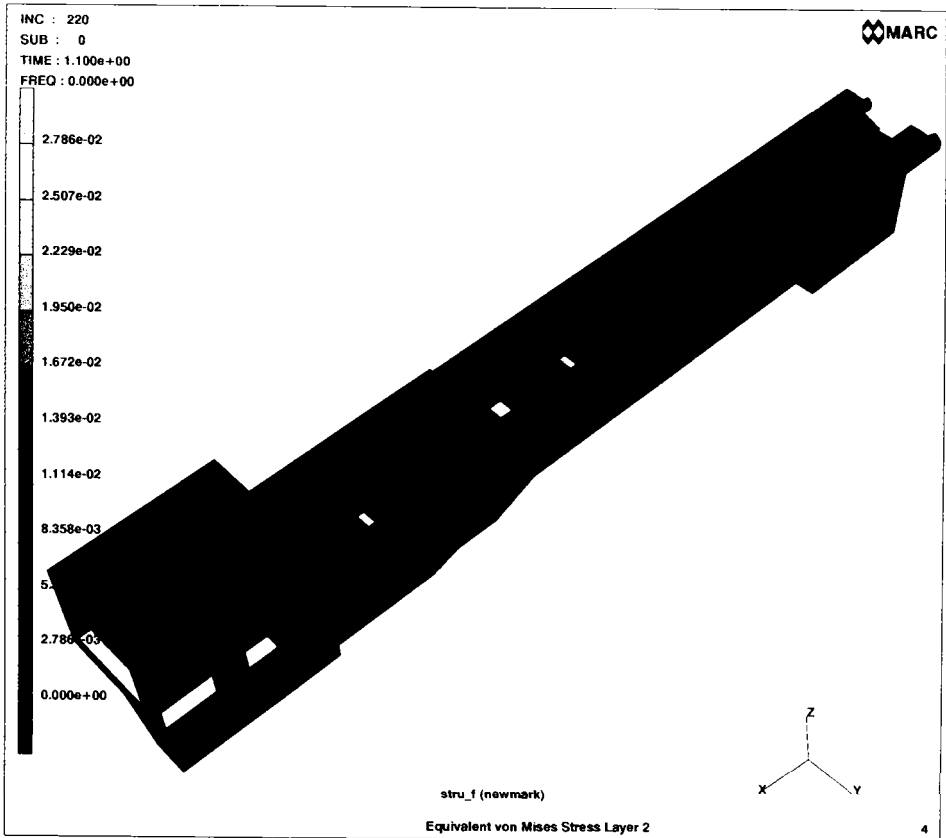

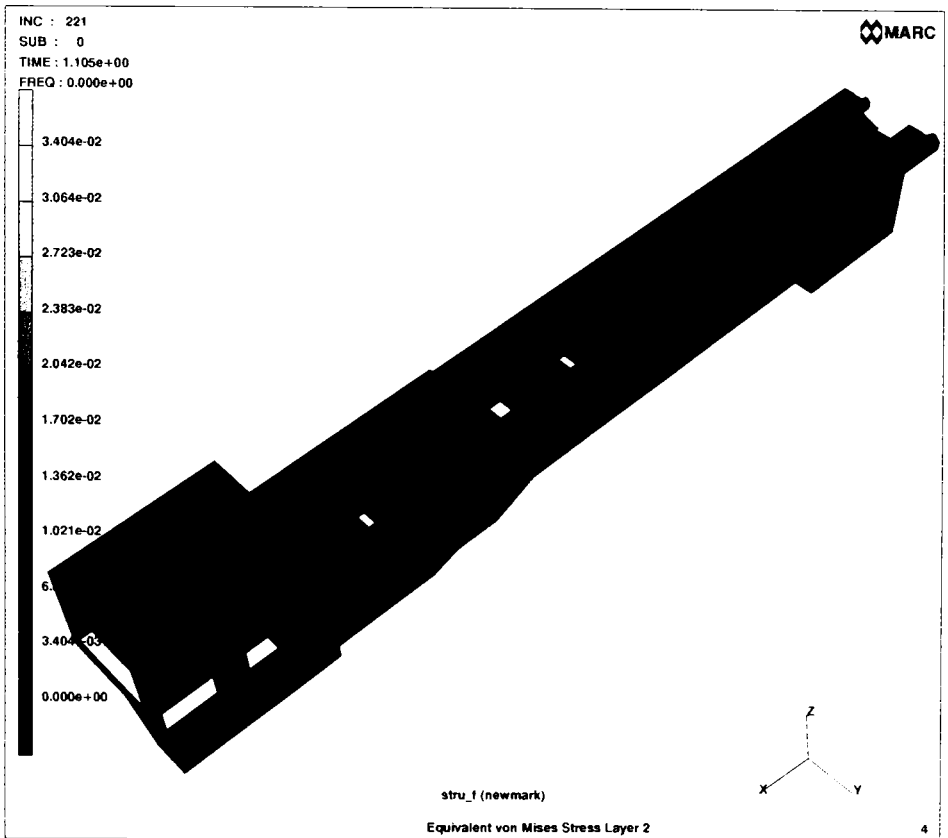

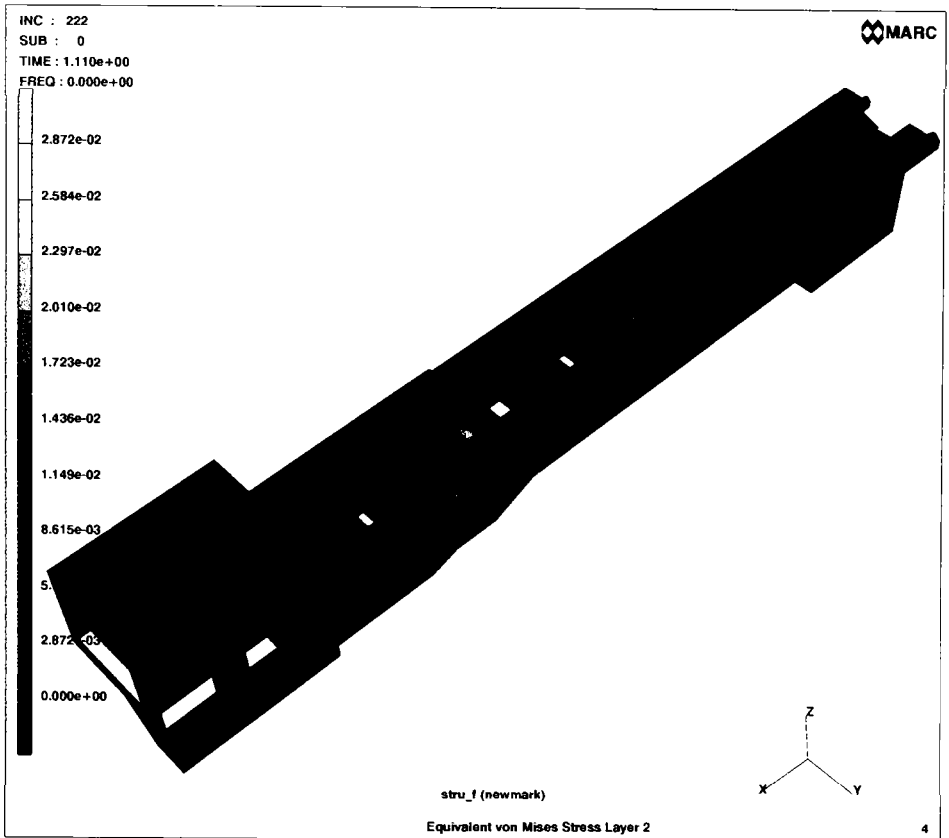

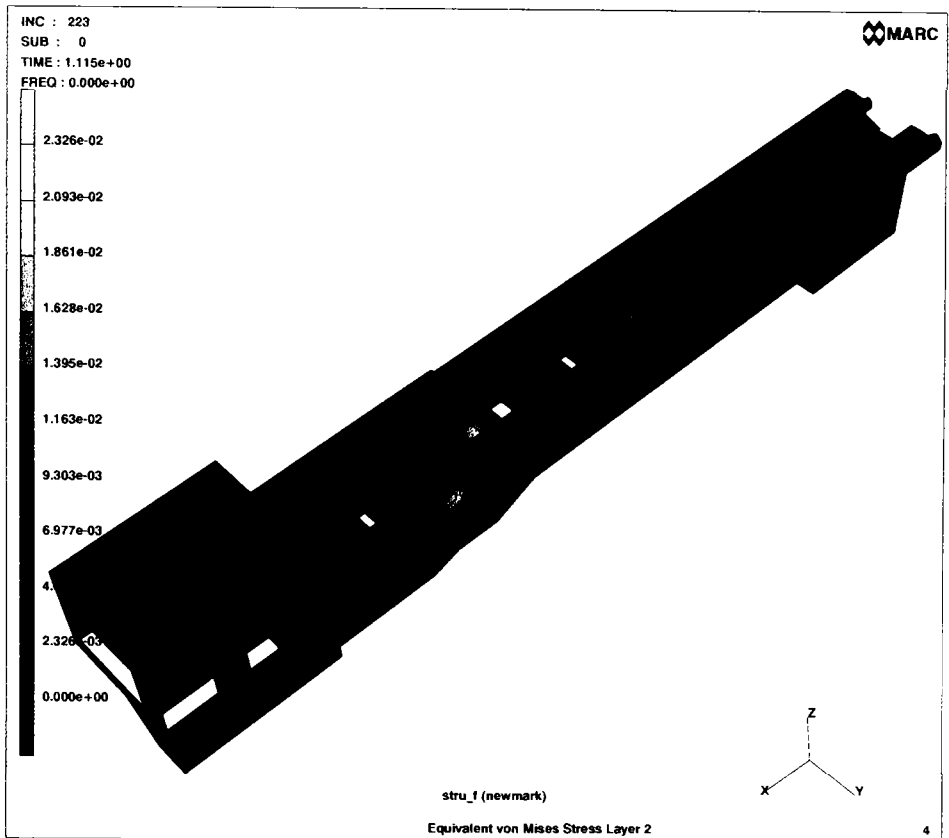

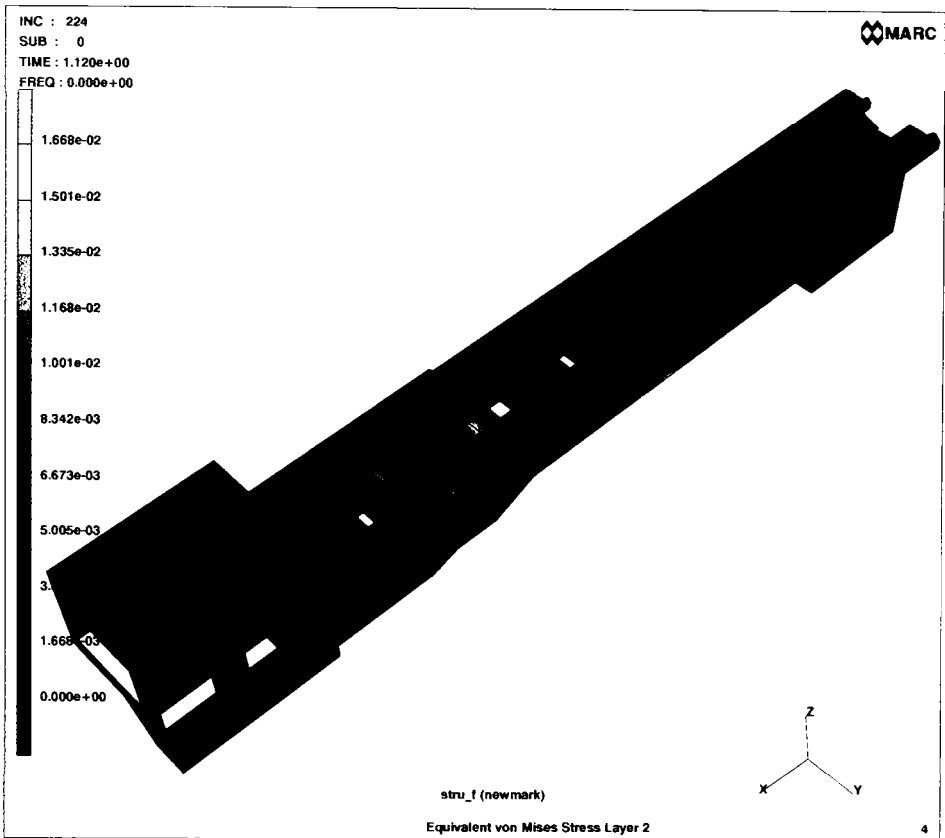

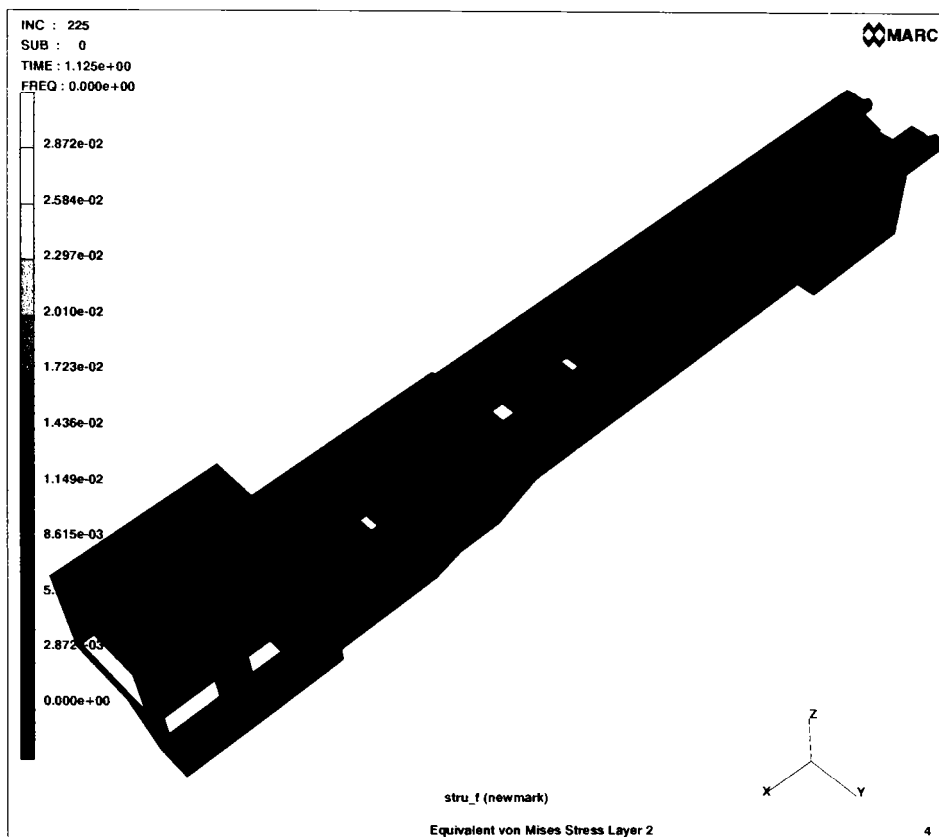

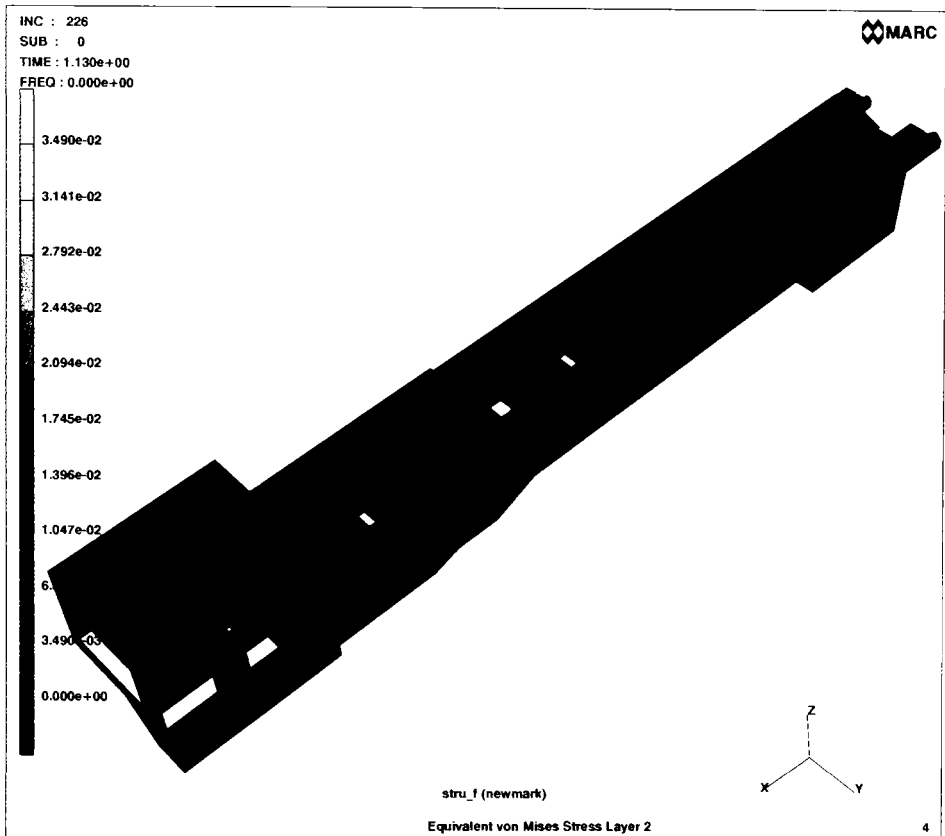

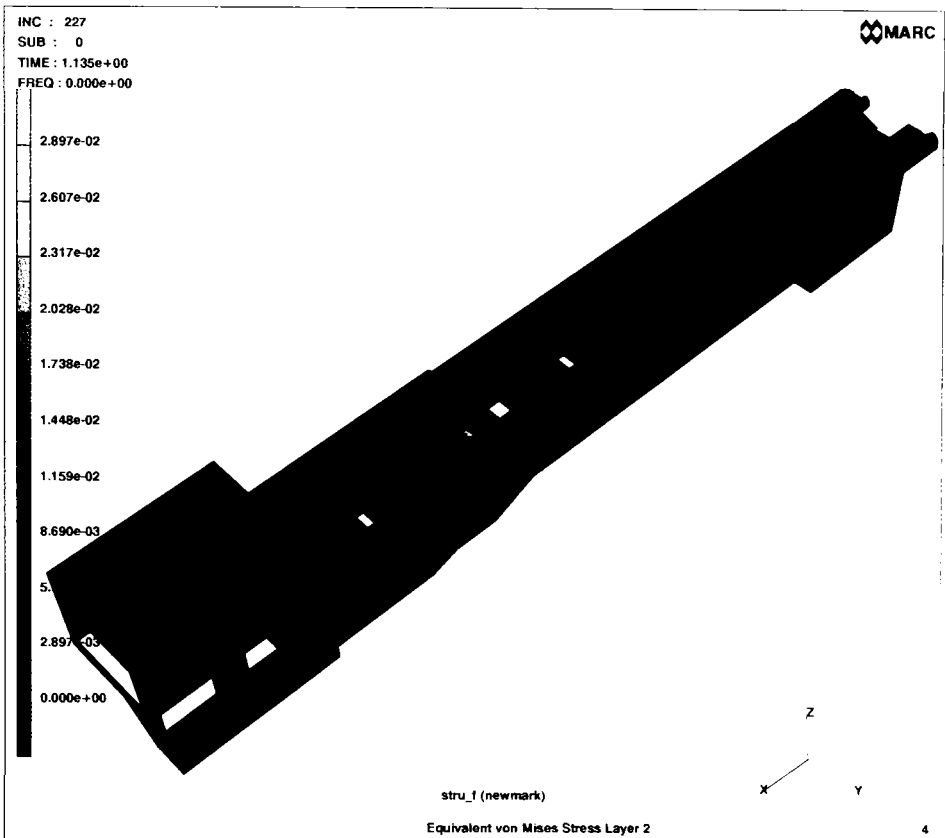

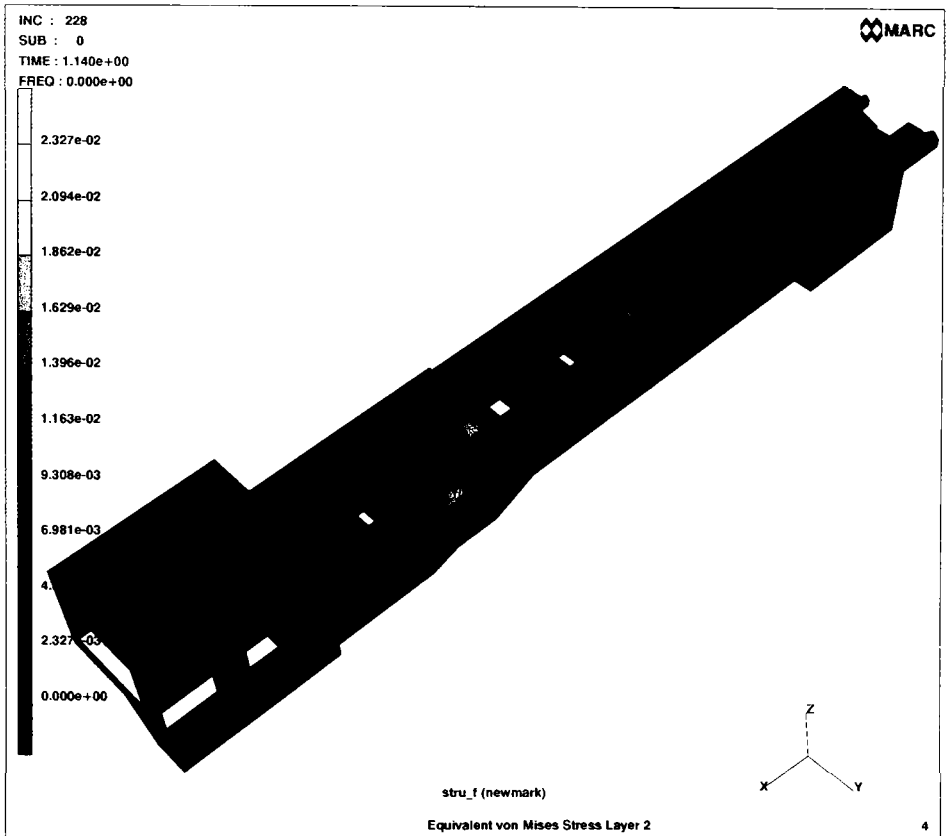

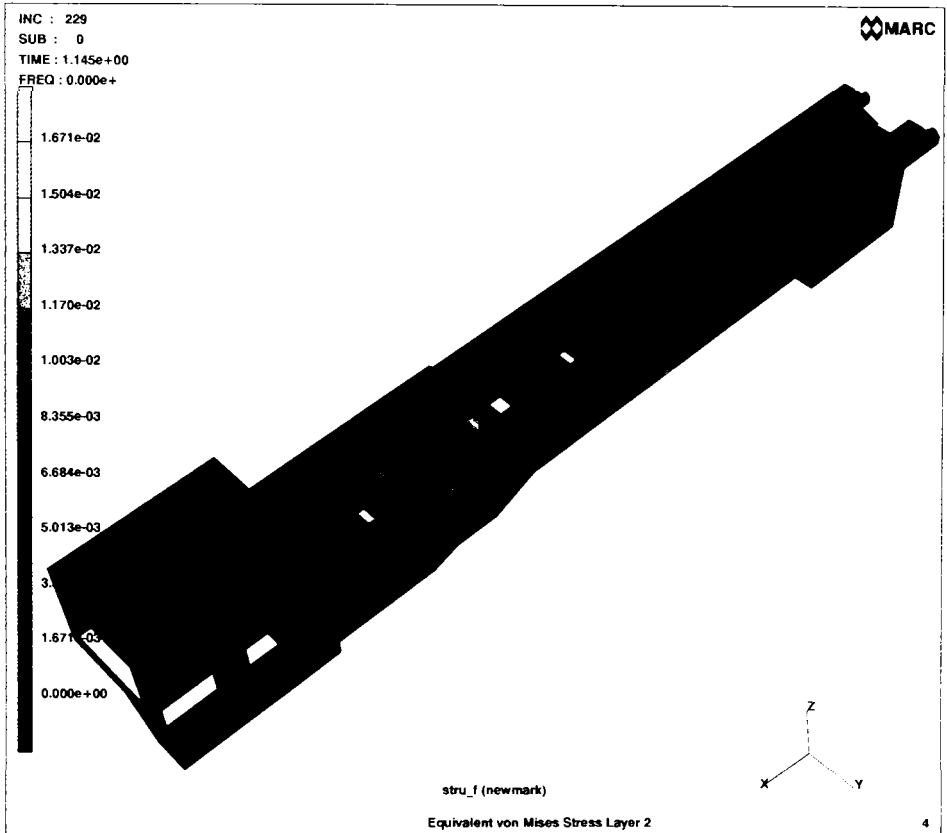

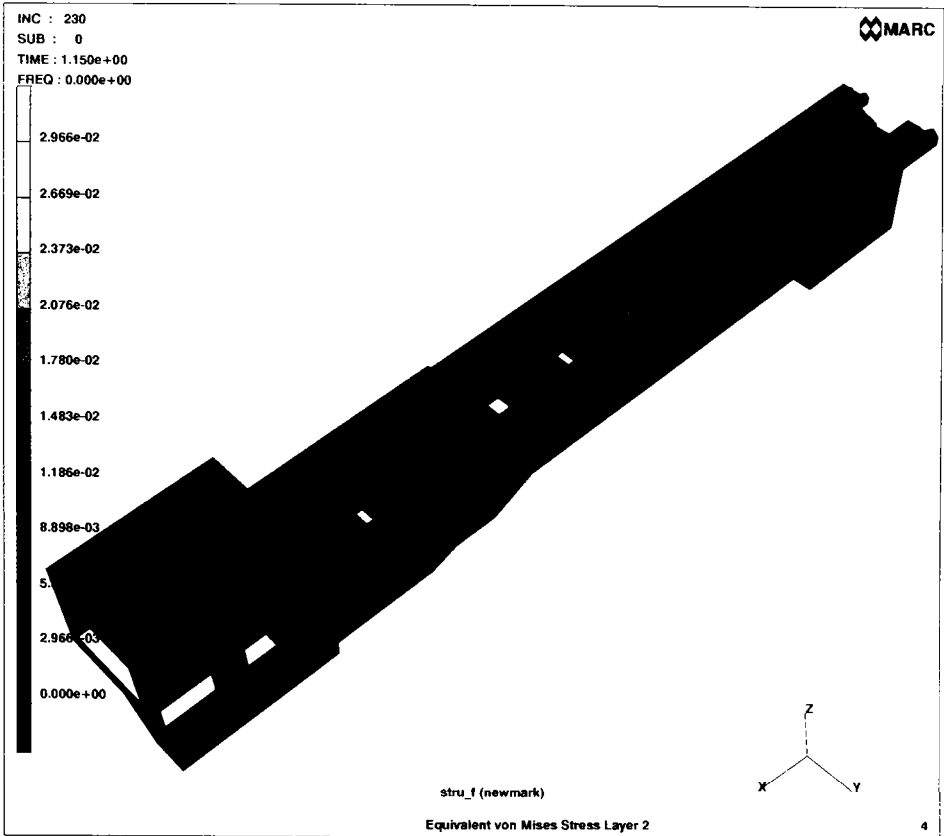

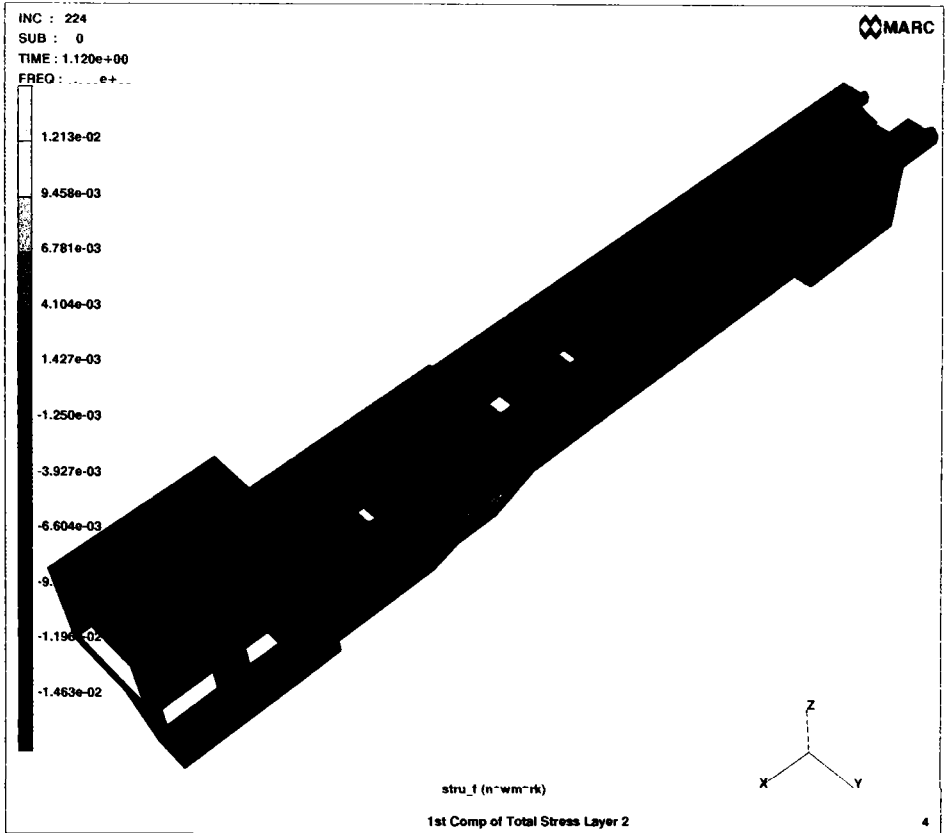

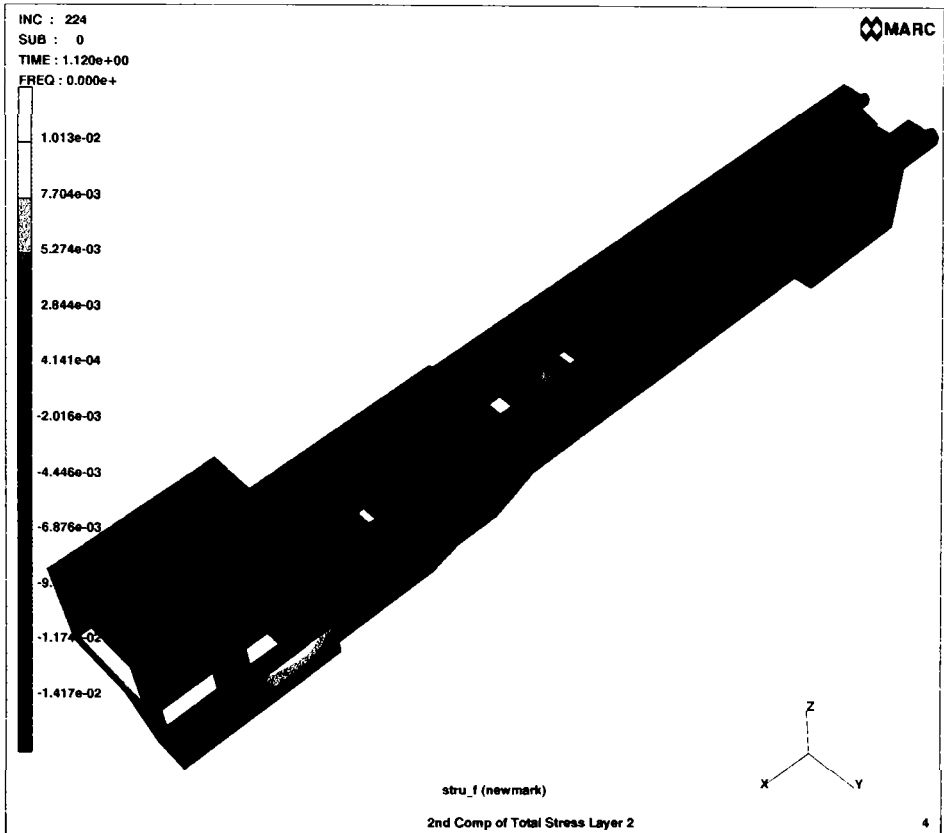

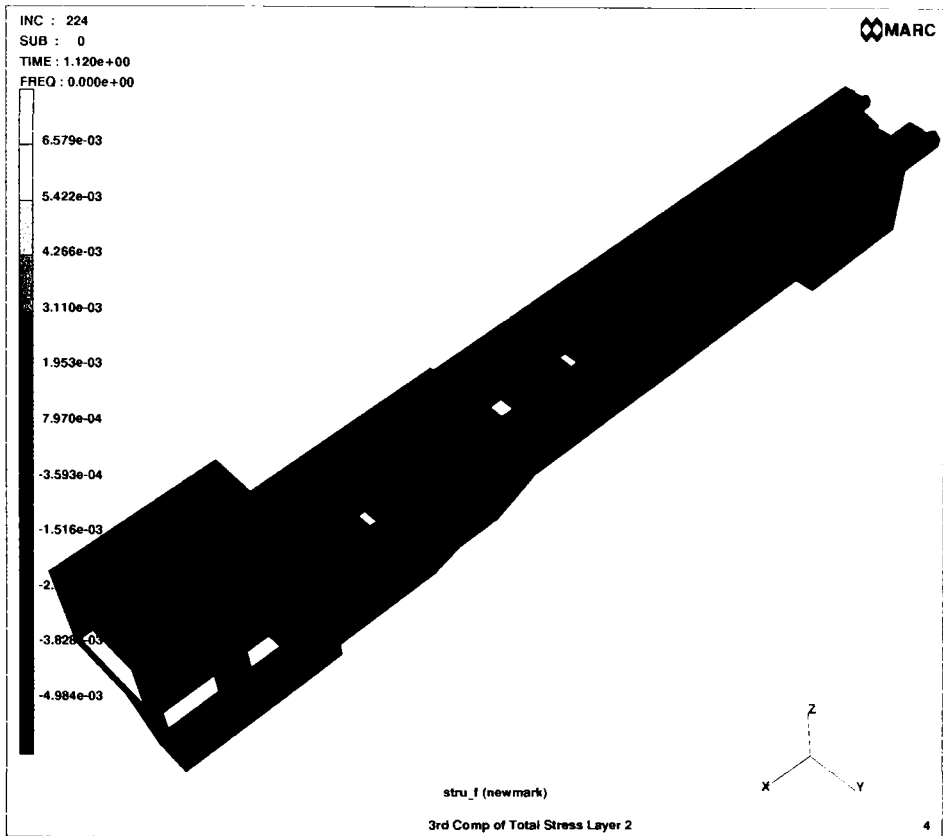

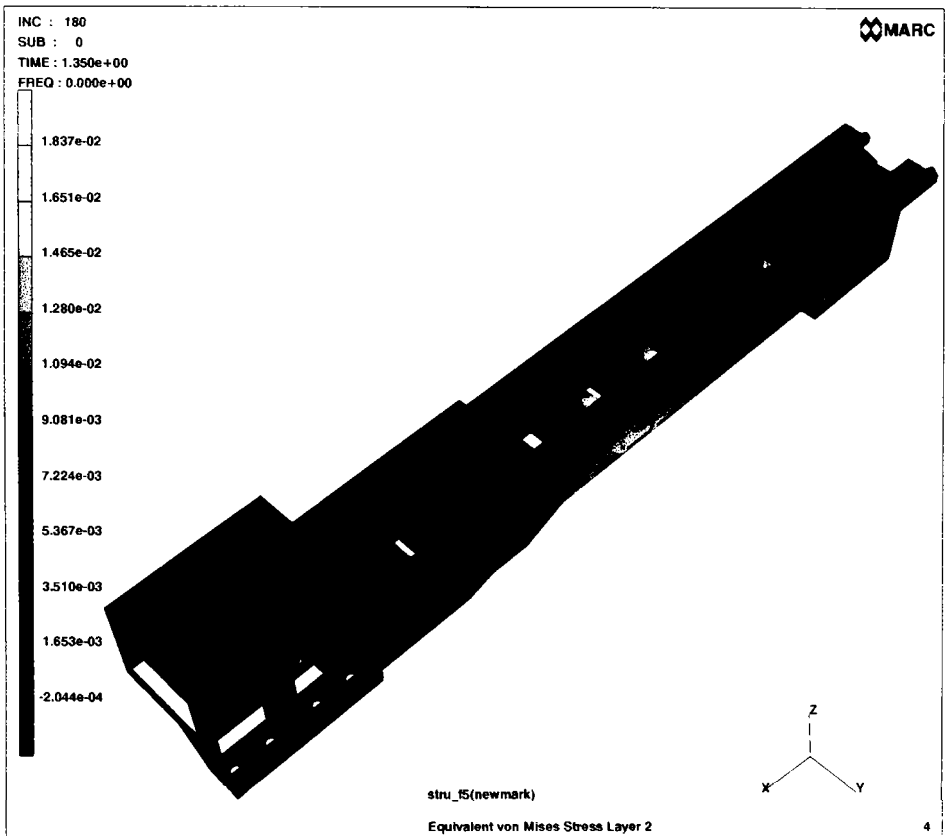

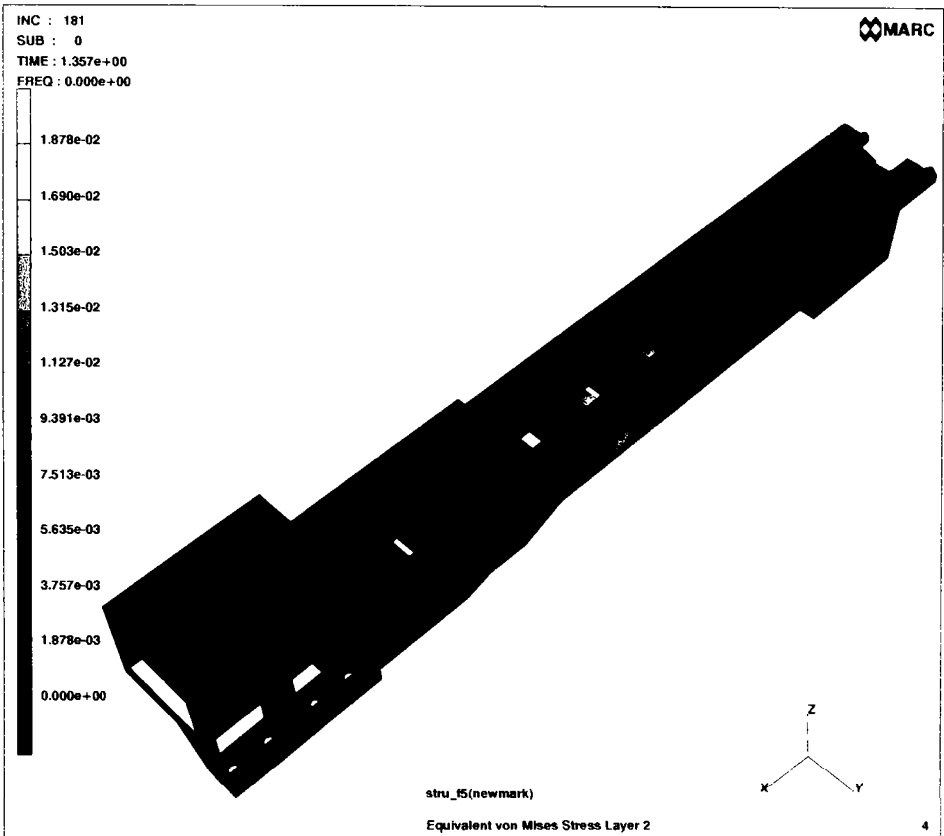

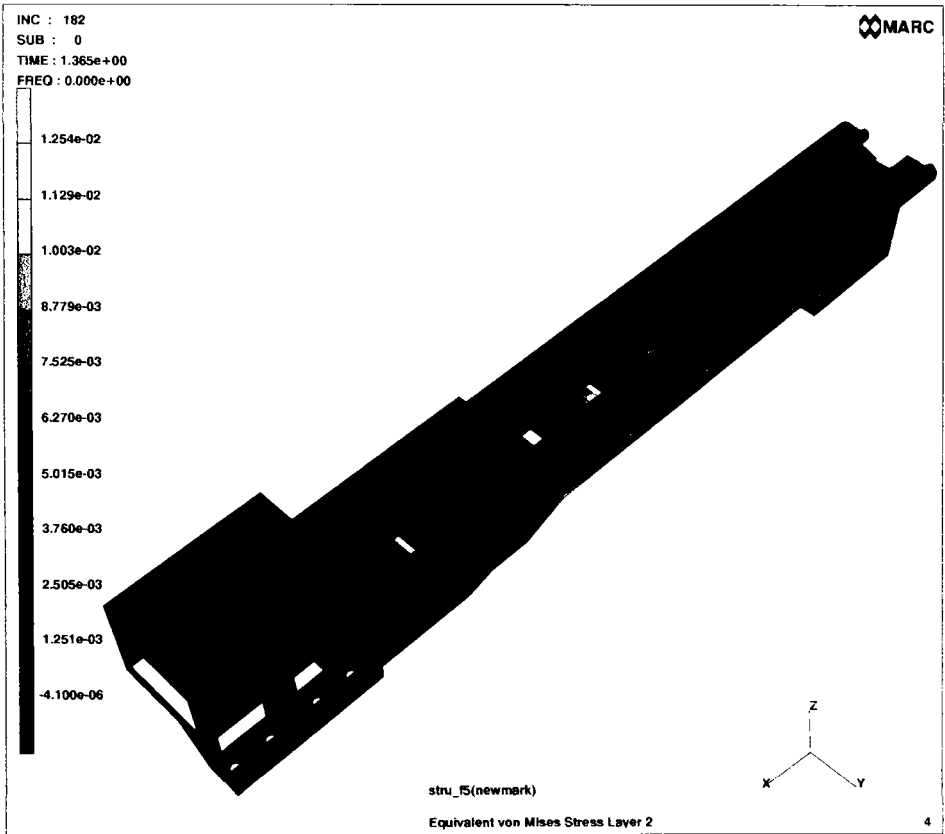

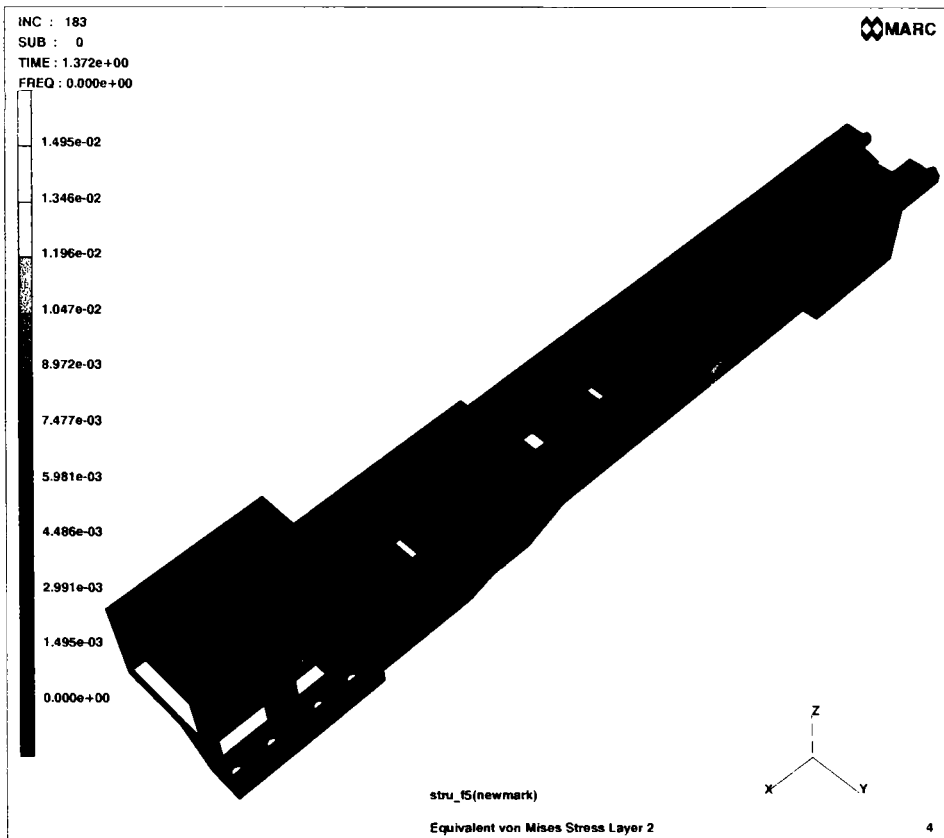

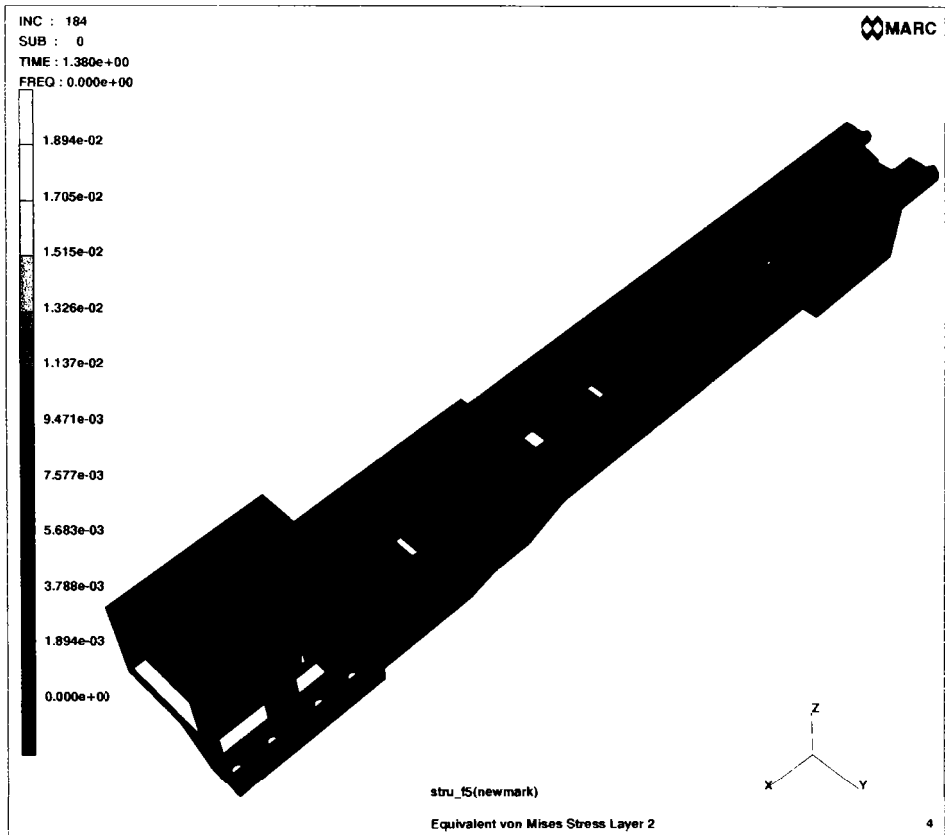

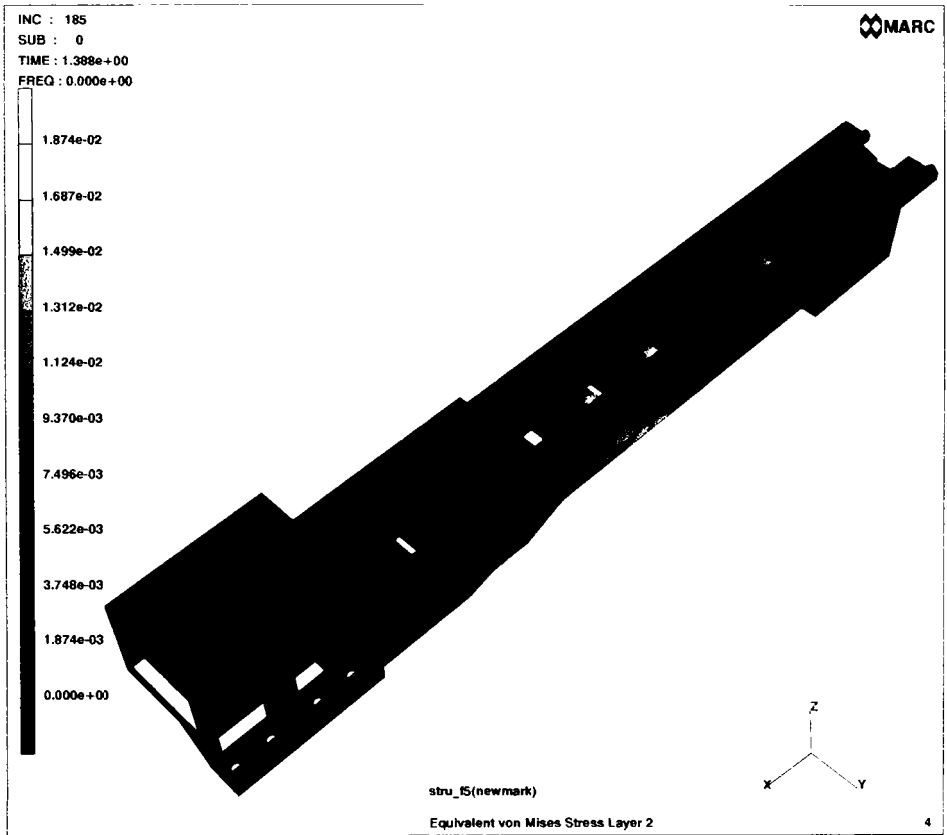

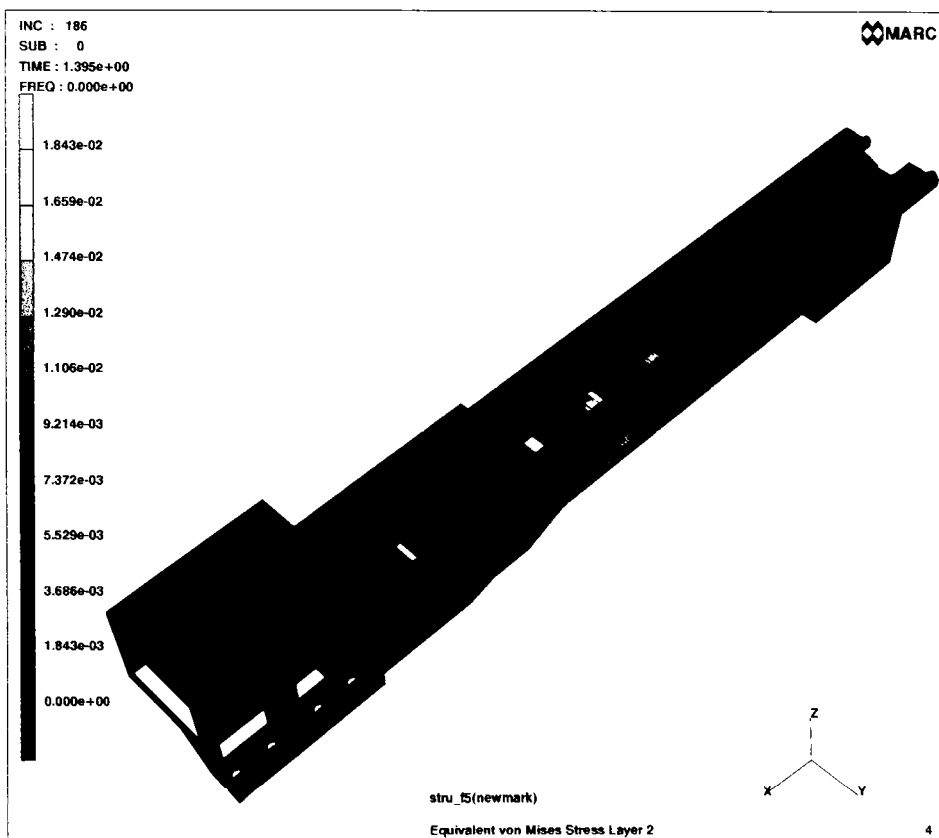

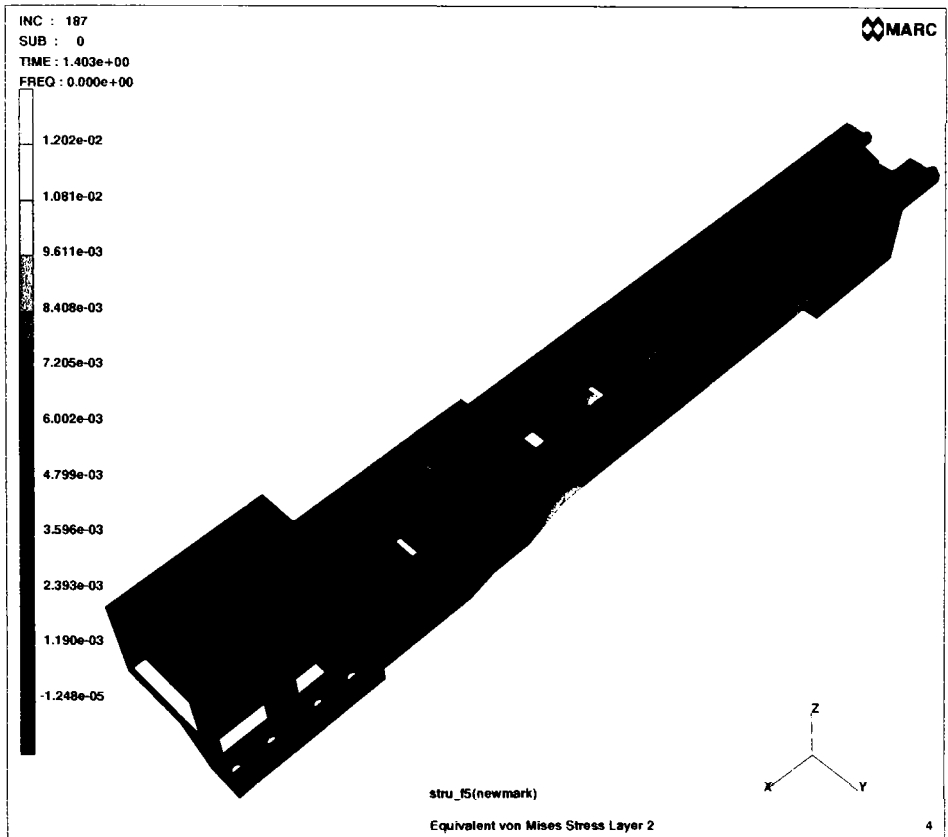

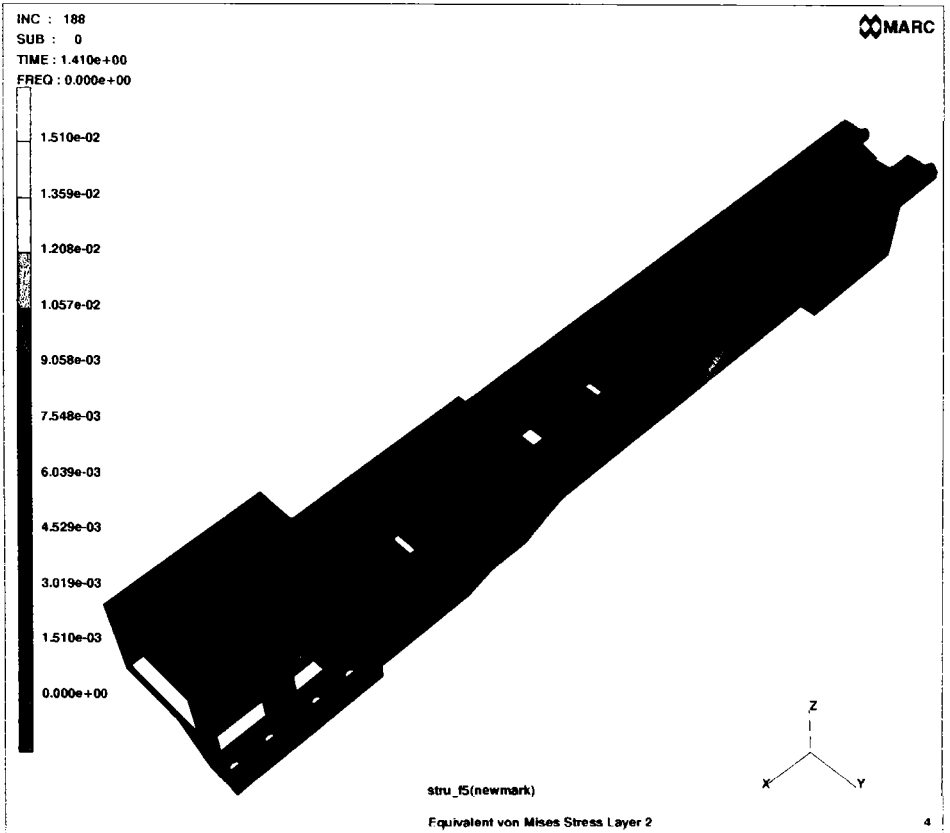

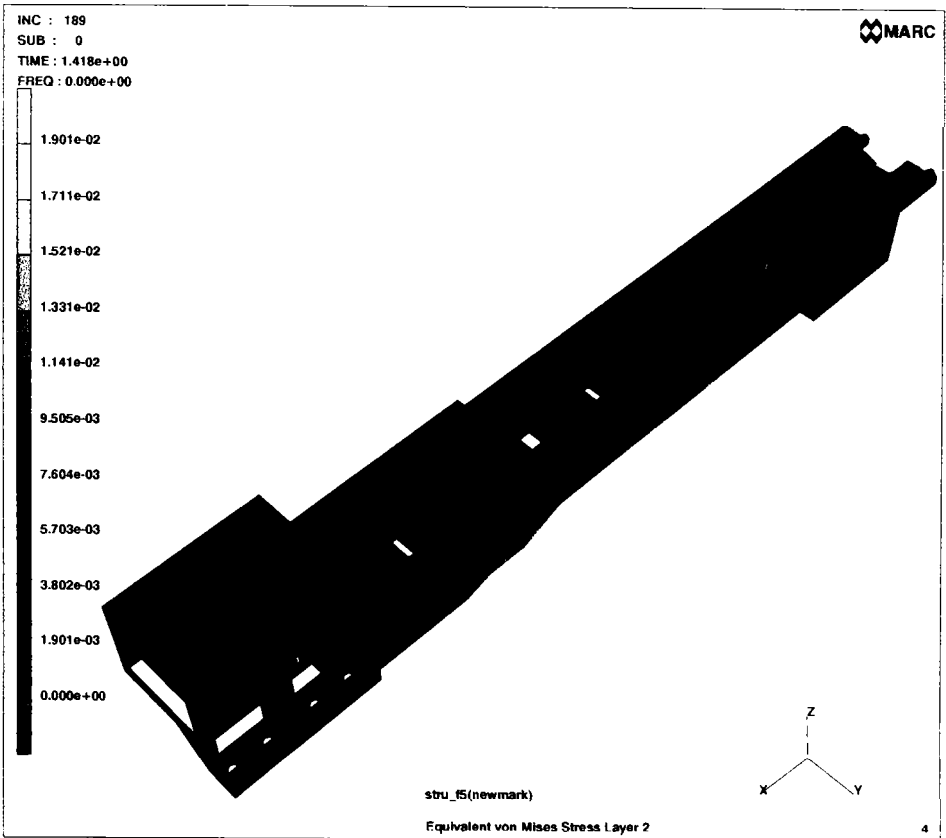

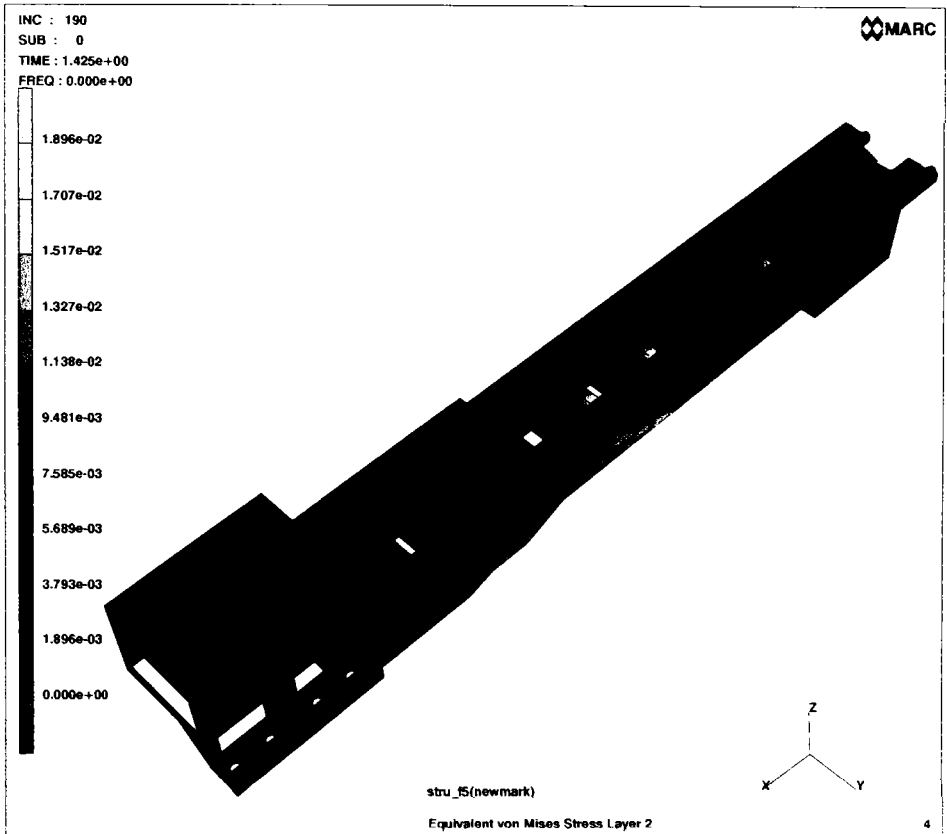

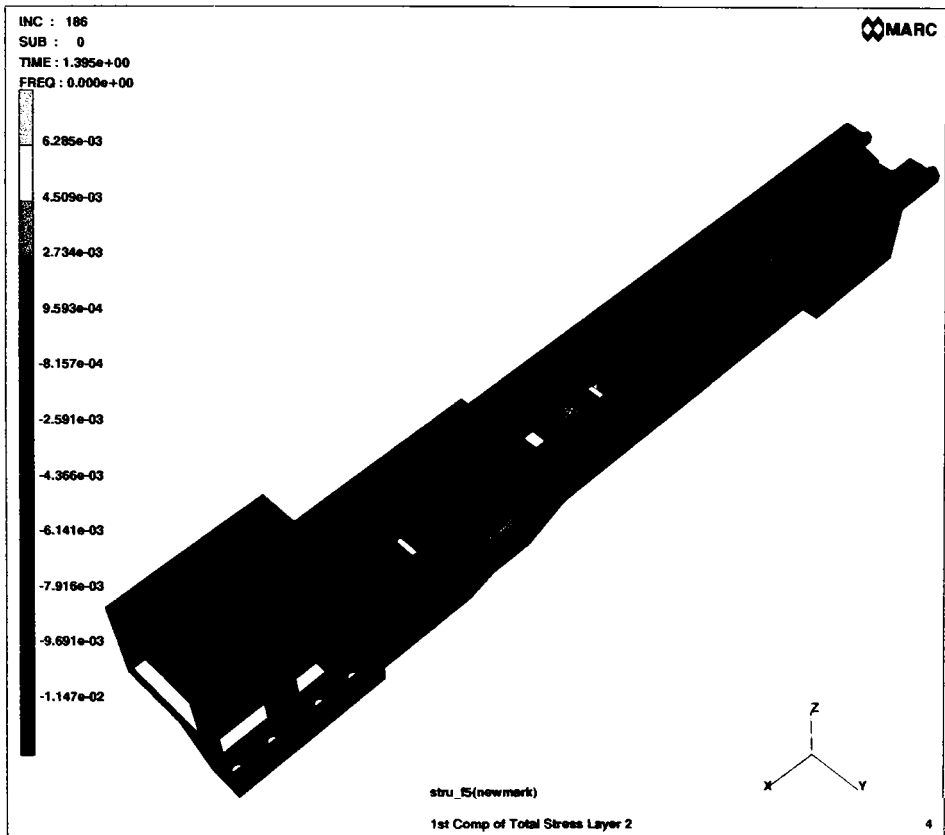

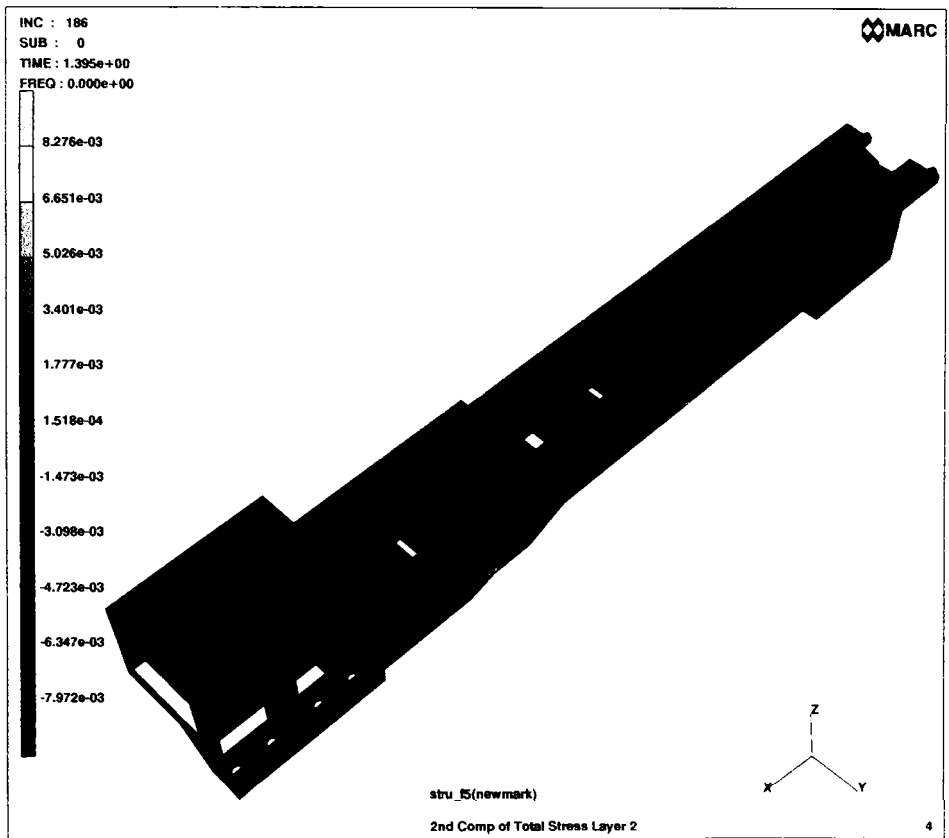

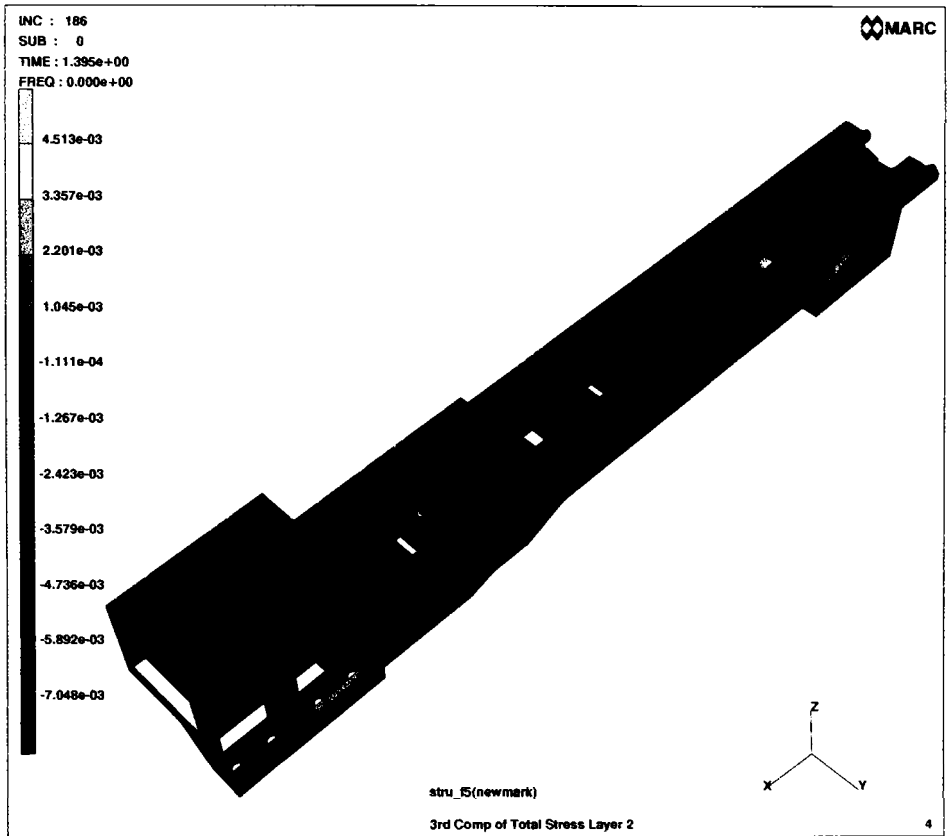

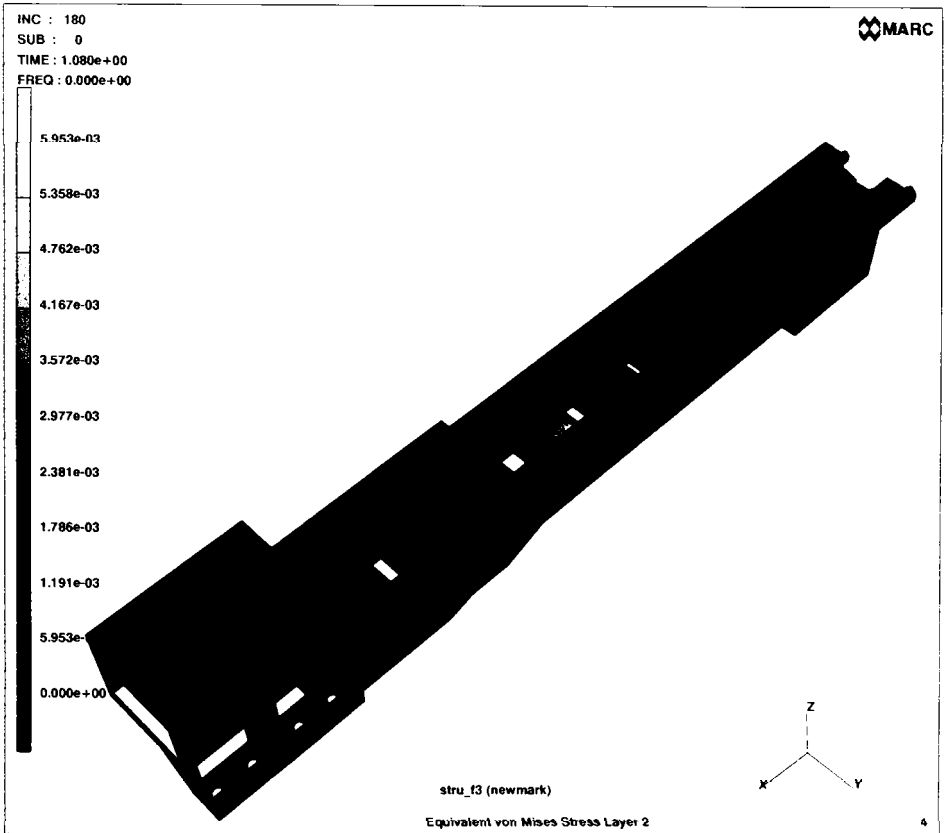

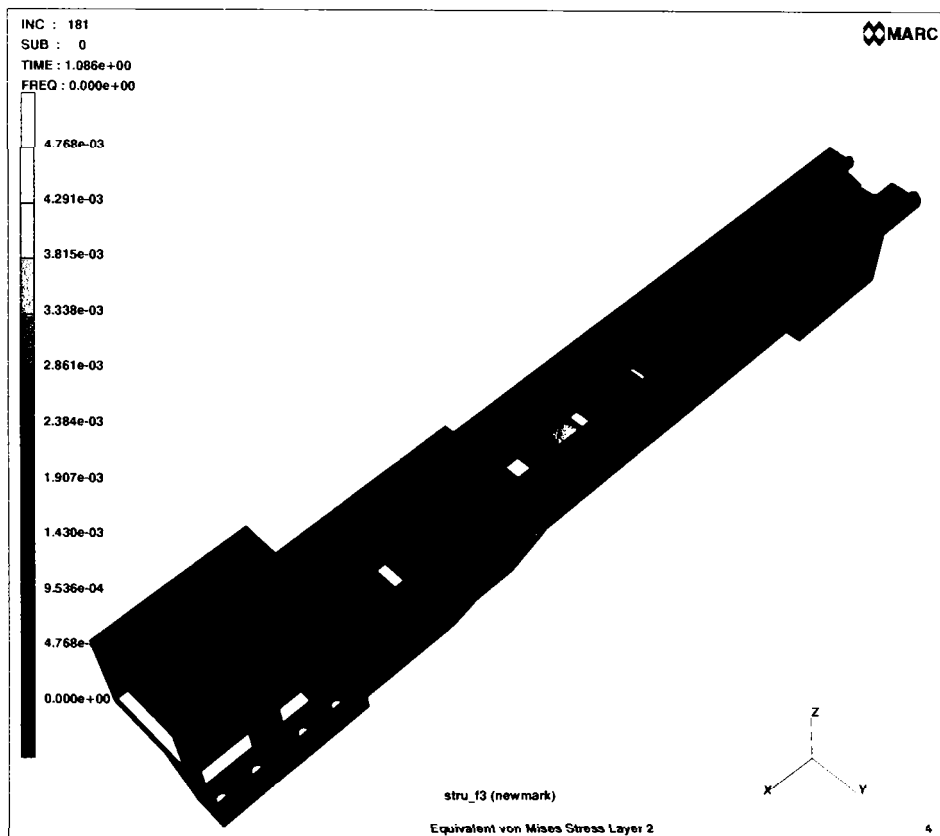

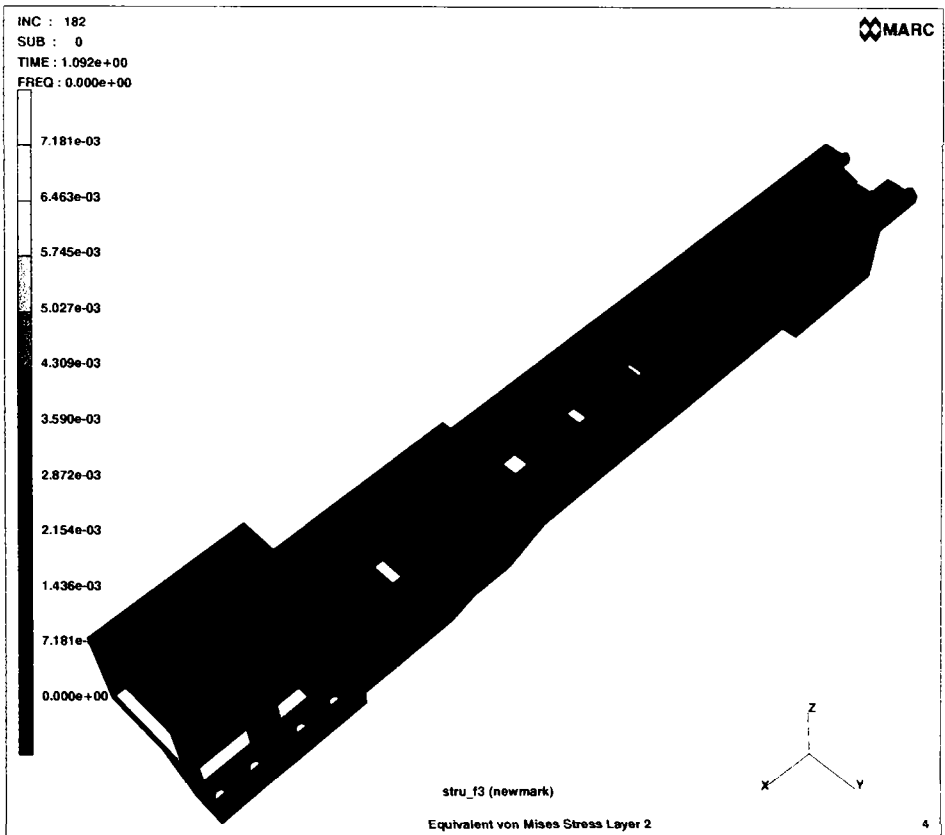

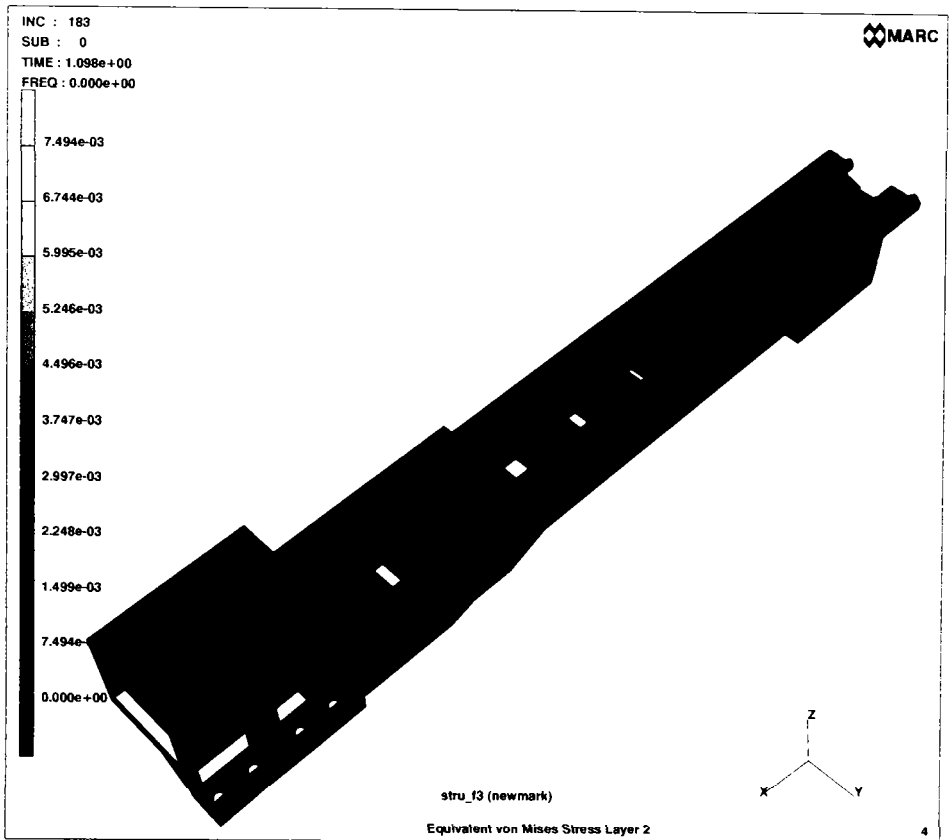

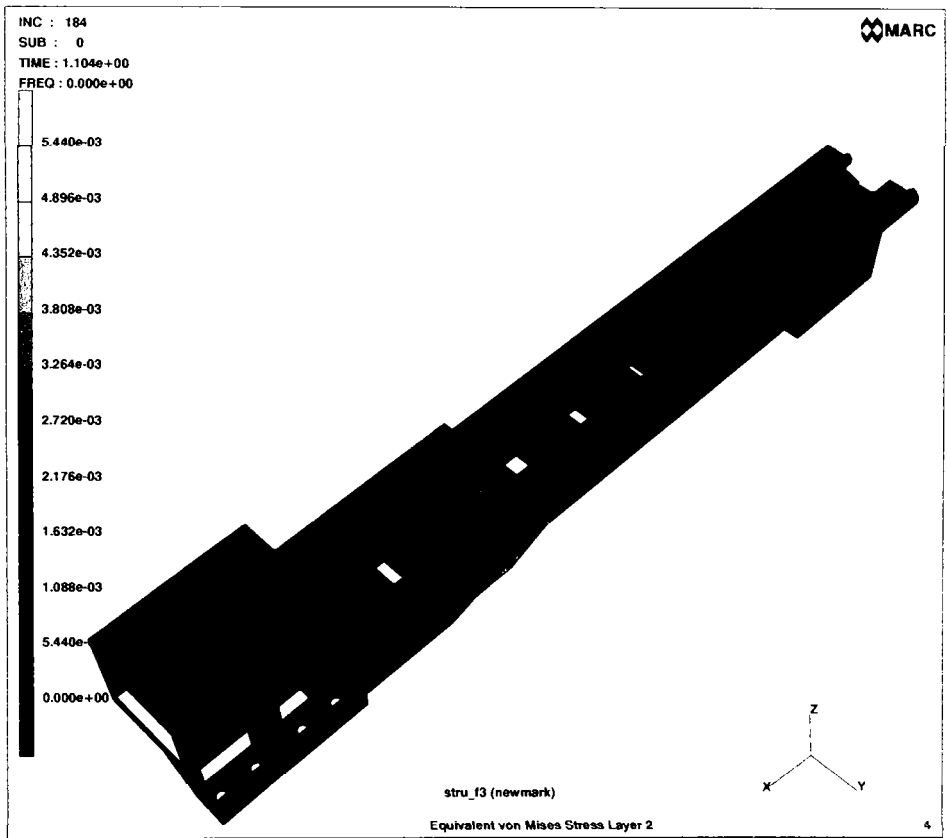

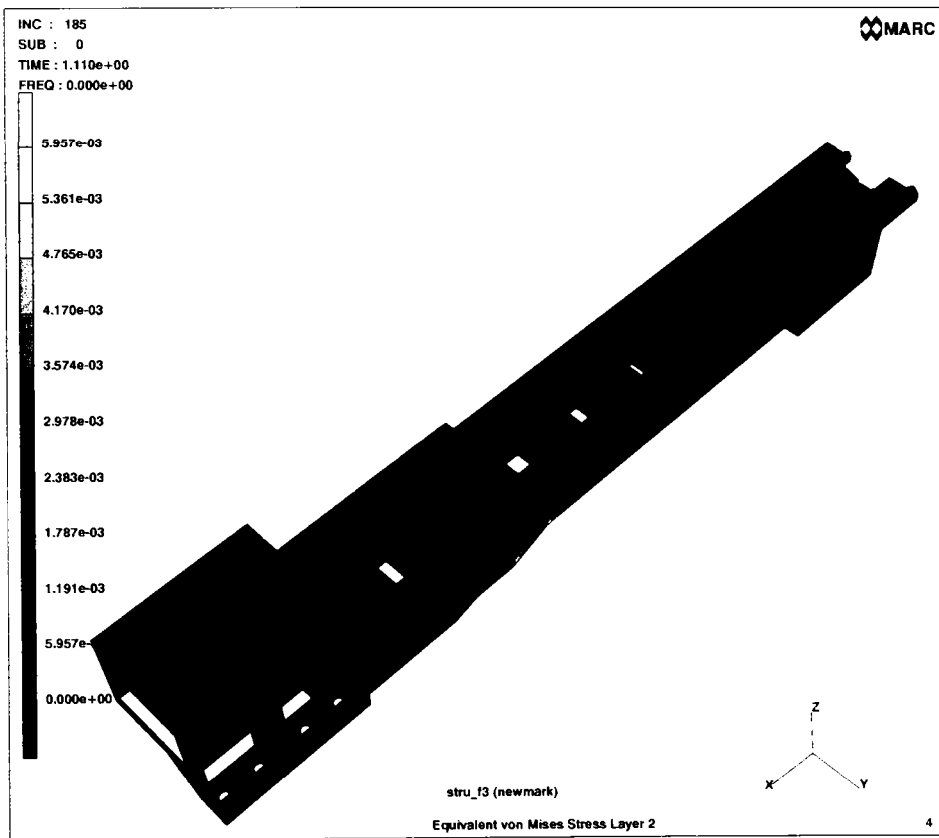

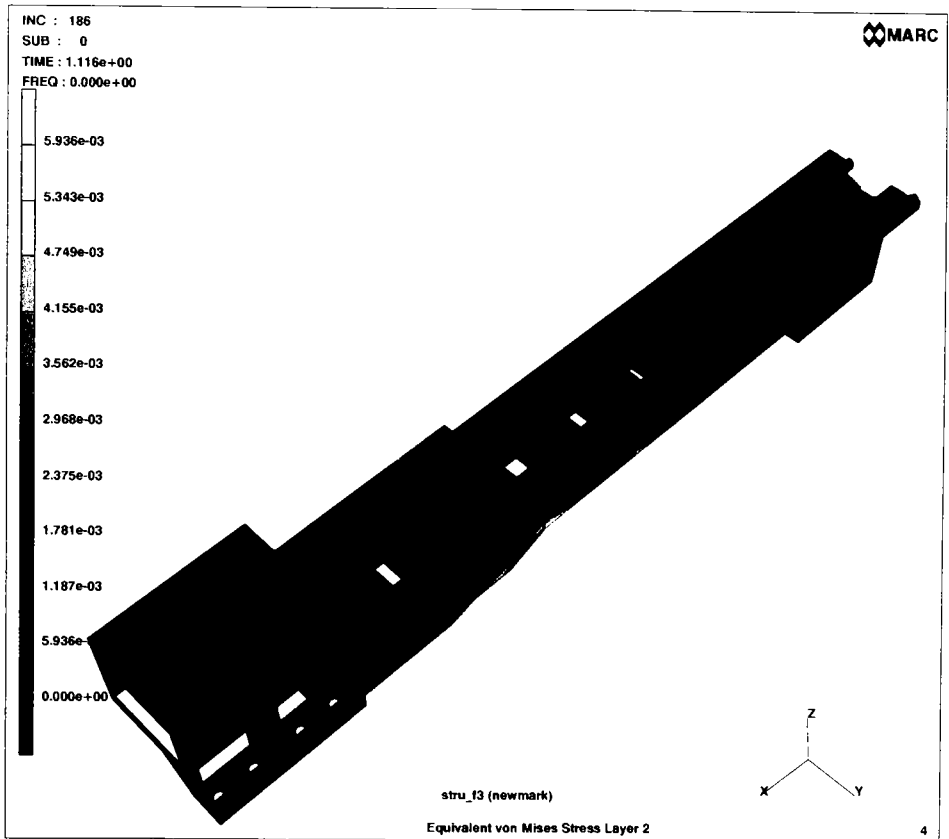

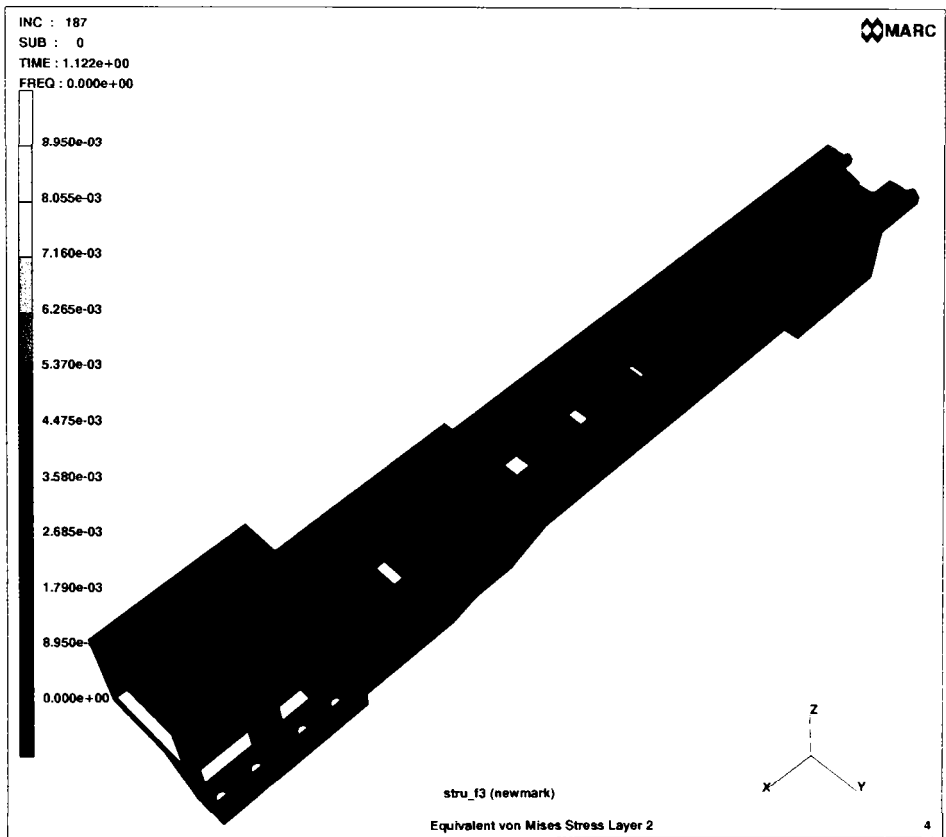

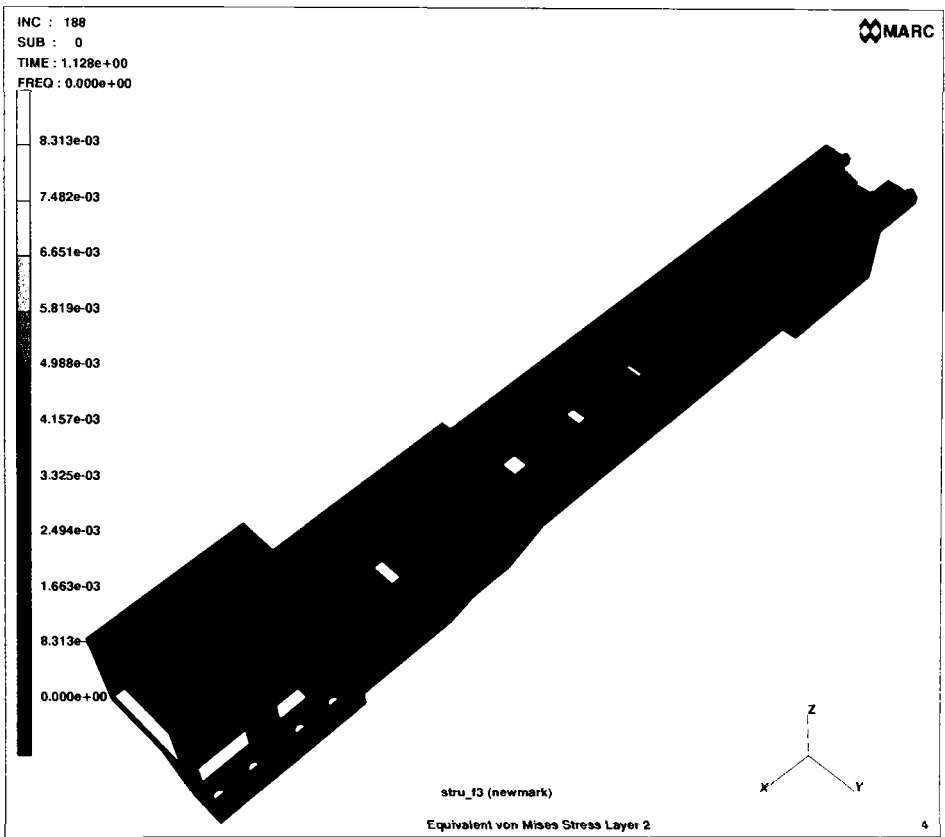

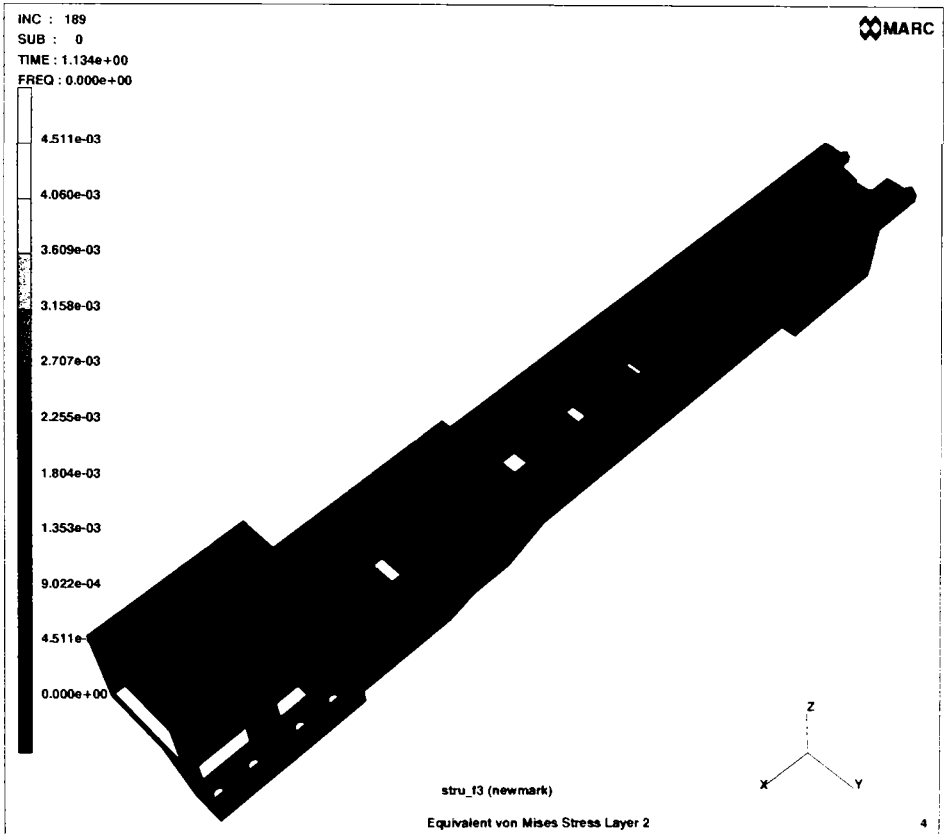

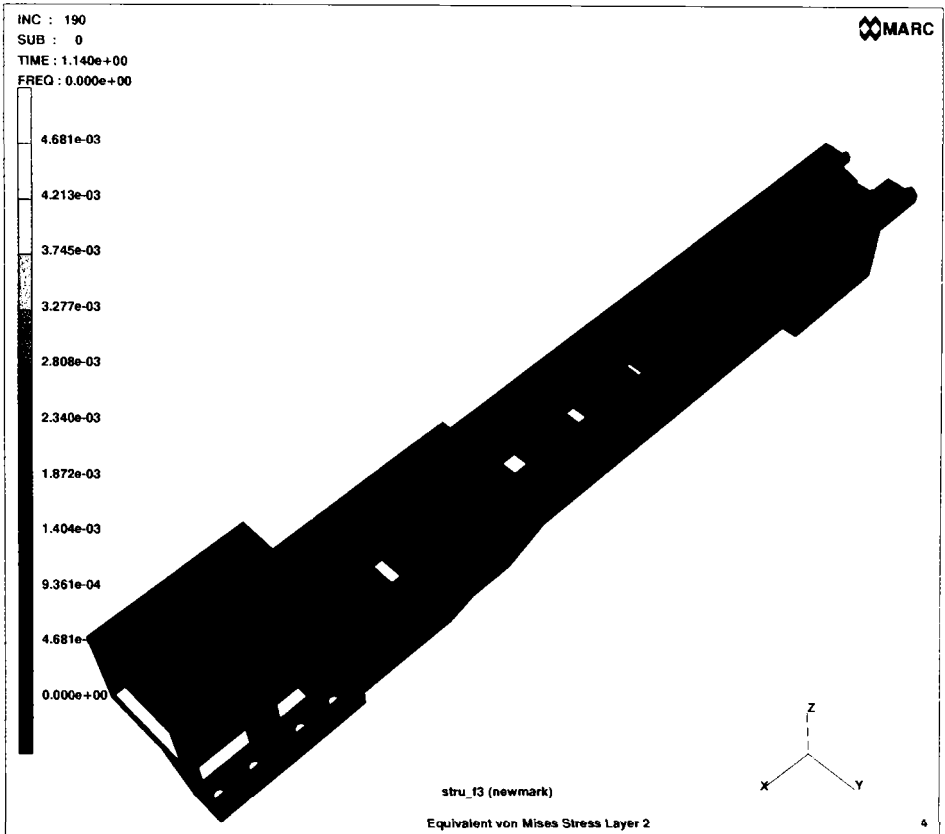

INC : 2
SUB : 0
TIME : 1.200e-02
FREQ : 0.000e+00

