

SATIN BOWERBIRD OPTIMIZATION ALGORITHM FOR THE APPLICATION OF OPTIMAL POWER FLOW OF POWER SYSTEM WITH FACTS DEVICES

Dr. Jagadeeswar Reddy Chintam¹, Dr. V. Geetha²,

¹Assistant Professor, Mekapati Rajamohan Reddy Institute of Technology & Science, Udayagiri, JNTU Anathapuram, SPSR Nellore 524226, India

²Professor and HOD, Dept. of EEE, Government College of Engineering, Salem, Tamil Nadu 636011, India

chreddygct@gmail.com¹, drvgeetha1967@gmail.com²

Abstract: The following research paper, addresses the issue of the optimal power flow (OPF) of power system dealt by the proposal of adapting flexible ac transmission FACTS devices with Satin Bowerbird optimization (SBBOA) algorithm. The SBBOA is bio-inspired algorithm; it is carried out based totally on the principle of 'female-attracted-by-male' for breeding. The algorithm that is proposed is tested by using IEEE-30 bus test systems with FACT devices of two different types. The following are the two types of FACT devices that are kept at fixed locations:

- (i) Thyristor controlled series capacitor and
 - (ii) Thyristor controlled phase shifter
- The objective of the present study aims at four different functions. They are:
- (a) Minimizing the cost of fuel
 - (b) Minimizing active power loss during transmission
 - (c) Reduction of emission and
 - (d) Minimizing the combination of economic and environmental cost.

The SBBOA give the finest simulation outcomes than lately proposed optimization algorithms given in the literature.

Keywords: optimal power flow, optimization, Satin Bowerbird optimization algorithm, FACTS devices.

1. Introduction

Recent day's OPF plays the most important role in managing and controlling modern power system with secure operation. It is also maintains a balance between the demand and generation with minimum cost of the production and maintenance without any interruption by the adjustment of control variables such as sizing of FACTS devices, generator active and reactive power, voltage of the generator bus, transformer tapping values [1], [2] etc. Past decades onwards various conventional and newly formed optimization techniques are applied to solve OPF problems such as Newton method [3], linear programming method [4], nonlinear programming method [5], quadratic programming method [6], interior point method [7], Gray wolf optimizer method [8], League

championship optimization method [9], Particle swarm optimization method [10], Satin Bowerbird Optimization method [11], Artificial bee colony optimization method [12], Magnetotactic bacteria moment migration optimization method [13], Hybrid Evolutionary Firefly Algorithm (HEFA) [14] etc.

The conventional and evolutionary optimization techniques are little modified by incorporating FACTS devices with better capability for solving OPF problems without disturbing the system's security. In [15], overloading issues of transmission lines are relieved and real power losses are minimized through the incorporation of UPFC and optimization of Symbiotic Organism Search (SOS) and Biogeography based krill herd algorithm. SOS and oppositional krill herd algorithm methods are applied to solve OPF problems on modified IEEE-30 and IEEE-57 bus systems equipped with both thyristor controlled series capacitor (TCSC) as well as with thyristor controlled phase shifter (TCPS). This functions with the objective of fuel cost minimization, with and without valve point effect, transmission line loss, emission and also with combined economic and emission cost [16], [17]. Symmetrical Distance Travelling Optimization algorithm (SDTO) is proposed for the parameters estimation and for selection of values with the best fitness function through proper controlling of optimal power flow in the transmission lines by incorporating multi FACTS devices [18].

Literature survey states that many different methods of new optimization techniques have been applied to find a solution to the conventional OPF problem of power systems. Literature survey also reveals that the solution of OPF problem of the power network along with FACTS devices requires the use of optimization techniques to solve these problems.

Research are done continuously seeking to achieve better optimization by applying techniques towards finding a solution for engineering as well as non-engineering applications. In [19], a novel Satin bowerbird optimization technique algorithm is introduced. In

SBBOA, adult males attract female birds during mating season by constructing a beautiful bower by using their own natural instinct and imagination. Following the nature of Satin Bowerbird's life model, SBBOA algorithm is developed. It is capable of solving problems in the engineering field with fast convergence rate and less computational time and is found to be very efficient.

In this work, the proposed SBBOA is tested on modified IEEE-30 for providing better solutions to OPF problems along with the help of FACTS devices with different objectives functions such as (i) minimizing fuel cost (with and without valve point effect), (ii) minimizing of both economic and environmental cost, (iii) reduction of emission, and (iv) minimizing active power loss during

transmission. Based on the literature survey, the TCSC and TCPS devices are placed at constant locations. The superior results so obtained are compared with other computational algorithms results that have already been done and given.

2. Mathematical modelling of TCSC and TCPS

The concept of TCSC and their advantages is given in reference[20], [21]. The static model of the network is seen with TCSC connected between i^{th} and j^{th} bus of the system as shown in Figure 1(a). The power flow equations of the branch having TCSC are given by Eq.(1) and Eq.(2) [22].

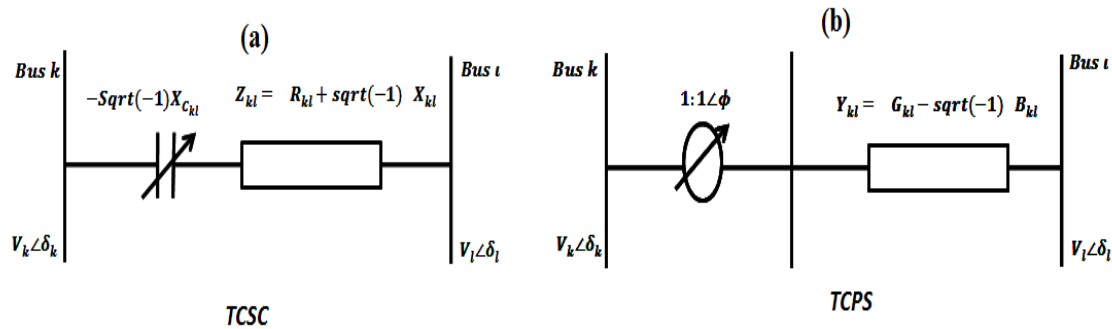

Figure 1: Represents (a) Single line circuit diagram of TCSC connected in-between buses of k^{th} and l^{th} , (b) Single line circuit diagram of TCPS connected in-between buses of k^{th} and l^{th}

$$P_{kl} = V_k^2 G_{kl} - V_k V_l G_{kl} \cos(\delta_k - \delta_l) - V_k V_l B_{kl} \sin(\delta_k - \delta_l) \quad (1)$$

$$Pr_{kl} = -V_k^2 B_{kl} - V_k V_l G_{kl} \sin(\delta_k - \delta_l) - V_k V_l B_{kl} \cos(\delta_k - \delta_l) \quad (2)$$

Similarly, real and reactive power flows in-between l^{th} to k^{th} bus is expressed by the Eq.(3) and Eq.(4)

$$P_{lk} = V_l^2 G_{kl} - V_k V_l G_{kl} \cos(\delta_k - \delta_l) - V_k V_l B_{kl} \sin(\delta_k - \delta_l) \quad (3)$$

$$Pr_{lk} = -V_l^2 B_{kl} - V_k V_l G_{kl} \sin(\delta_k - \delta_l) - V_k V_l B_{kl} \cos(\delta_k - \delta_l) \quad (4)$$

Where

$$\text{Conductance}(G_{kl}) = \frac{R_{kl}}{R_{kl}^2 + (X_{kl} - X_{C_{kl}})^2}; \quad \text{and} \quad \text{Susceptance}(B_{kl}) = \frac{X_{kl} - X_{C_{kl}}}{R_{kl}^2 + (X_{kl} - X_{C_{kl}})^2}.$$

In Figure 1(b) is shown the TCPS model with connection in-between k^{th} and l^{th} buses, which also has a complex tapping ratio of $1:1\angle\phi$ and series admittance of $Y_{kl} = (G_{kl} - jB_{kl})$ [12,14]. Similarly, TCSC model of real and reactive power flows from k^{th} to l^{th} bus are expressed by Eq.(5) and Eq.(6) [22].

$$P_{kl} = \frac{V_k^2 G_{kl}}{\cos^2 \phi} - \frac{V_k V_l}{\cos \phi} [G_{kl} \cos(\delta_k - \delta_l + \phi) + B_{kl} \sin(\delta_k - \delta_l + \phi)] \quad (5)$$

$$Pr_{kl} = -\frac{V_k^2 B_{kl}}{\cos^2 \phi} - \frac{V_k V_l}{\cos \phi} [G_{kl} \sin(\delta_k - \delta_l + \phi) + B_{kl} \cos(\delta_k - \delta_l + \phi)] \quad (6)$$

Real and reactive-power flows in-between buses l^{th} to k^{th} are expressed by Eq.(7) and Eq.(8)

$$P_{kl} = V_k^2 G_{kl} - \frac{V_k V_l}{\cos \phi} [G_{kl} \cos(\delta_k - \delta_l + \phi) + B_{kl} \sin(\delta_k - \delta_l + \phi)] \quad (7)$$

$$Pr_{kl} = -V_k^2 B_{kl} + \frac{V_k V_l}{\cos \phi} [G_{kl} \sin(\delta_k - \delta_l + \phi) + B_{kl} \cos(\delta_k - \delta_l + \phi)] \quad (8)$$

The injected real and reactive-powers of TCPS at k^{th} and l^{th} buses are given by the Eq.(9) – Eq.(12)

$$P_{ks} = -G_{kl} V_k^2 \tan^2 \phi - V_m V_l \tan \phi [G_{ij} \sin(\delta_k - \delta_l) - B_{kl} \cos(\delta_k - \delta_l)] \quad (9)$$

$$Pr_{ks} = B_{kl} V_k^2 \tan^2 \phi - V_k V_l \tan \phi [G_{kl} \cos(\delta_k - \delta_l) - B_{kl} \sin(\delta_k - \delta_l)] \quad (10)$$

$$P_{ks} = -V_m V_l \tan \phi [G_{kl} \sin(\delta_k - \delta_l) - B_{kl} \cos(\delta_k - \delta_l)] \quad (11)$$

$$Pr_{ks} = -V_k V_l \tan \phi [G_{kl} \cos(\delta_k - \delta_l) - B_{kl} \sin(\delta_k - \delta_l)] \quad (12)$$

3. Problem formulation of OPF with FACTS

The objective of the newly proposed OPF is to minimize the objective function (OBF) while satisfying all constraints of equality and inequality. The OPF problem is formulated by Eq.(13) and Eq.(14) [23]–[25].

$$\text{Minimize OBF}(x, y) \quad (13)$$

$$\text{Subject to: } \begin{cases} \text{eq}(x, y) = 0 \\ \text{ieq}_k \leq \text{ieq}(x, y) \leq \text{ieq}_l \end{cases} \quad (14)$$

The power flow based on changing of generators' active powers except slack bus, generators' voltages and discrete variables are transformers' tap settings, reactive power injections of shunt regulators, reactance values of TCSC devices and phase shifting angles of TCPS devices. Hence, x and y may be expressed by (15) and (16), correspondingly,

$$x^T = [P_{G1}, V_{L1}, \dots, V_{LNL}, Q_{C1} \dots Q_{CNG}, S_{11} \dots S_{INTL}] \quad (15)$$

$$y^T = [P_{G2}, P_{GNG}, V_{G1} \dots V_{GNG}, T_1 \dots T_{NT}, Q_{C1} \dots Q_{CNC}] \quad (16)$$

3.1. Equality and Inequality constraints:

The OPF with the TCSC and TCPS are subjected to the both equality and inequality constraints mentioned in following.

These equality constraints of the load flow equations given in Eq.(17),Eq.(18)[22].

$$\sum_{k=1}^{NGB} (P_{Gk} - P_{Lk}) + \sum_{k=1}^{NTCPS} P_{ks} = \sum_{k=1}^{NGB} \sum_{l=1}^{NGB} |V_k| |V_l| |Y_{kl}| \cos(\theta_{kl} + \delta_k - \delta_l) \quad (17)$$

$$\sum_{k=1}^{NGB} (Q_{Gk} - Q_{Lk}) + \sum_{k=1}^{NTCPS} Q_{ks} = \sum_{k=1}^{NGB} \sum_{l=1}^{NGB} |V_k| |V_l| |Y_{kl}| \sin(\theta_{kl} + \delta_k - \delta_l) \quad (18)$$

Inequality constraints of generator voltage, active and reactive-power, Load bus voltage, Transmission line, Transformer tap settings, Shunt compensators, TCSC reactors, TCPS phase shifters, of k^{th} bus must lie in-between minimum and maximum limits as given by Eq.(19) - Eq.(27)

$$V_{Gkmin} \leq V_k \leq V_{Gkmax} ; k=1, 2, \dots, NGB \quad (19)$$

$$P_{Gkmin} \leq P_k \leq P_{Gkmax} ; k=1, 2, \dots, NGB \quad (20)$$

$$Q_{Gimin} \leq Q_i \leq Q_{Gimax} ; k=1, 2, \dots, NGB \quad (21)$$

$$V_{Lkmin} \leq V_k \leq V_{Lkmax} ; k=1, 2, \dots, NLB \quad (22)$$

$$S_{lk} \leq S_{lkmax} ; k = 1, 2, \dots, NT \quad (23)$$

$$T_{Gkmin} \leq T_k \leq T_{Gkmax} ; k=1, 2, \dots, NRT \quad (24)$$

$$Q_{ckmin} \leq Q_{ck} \leq Q_{ckmax} ; k=1, 2, \dots, NS \quad (25)$$

$$X_{tkmin} \leq X_{ck} \leq X_{tkmax} ; k=1, 2, \dots, NTCSC \quad (26)$$

$$\phi_{tkmin} \leq \phi_{ck} \leq \phi_{tkmax} ; k=1, 2, \dots, NSC \quad (27)$$

3.2. Objective function

In this current work, SBBOA effectiveness tested on four different objective functions taken as follows:

(a) Minimizing fuel cost: This problem is aimed at minimizing the total fuel cost and at the same time satisfying all the equality and inequality constraints and may be formulated by Eq.(28)

$$\text{Minimize } G_{FC}(P_G) \quad (28)$$

where $G_{FC}(P_G)$ is the total generator fuel cost in \$/hr.

Generator units of total fuel cost (with Quadratic function) minimization without valve effect is given by Eq.(29) [26].

$$G_{FC}(P_G) = \left(\sum_{k=1}^{NG} F_k(P_{Gk}) \right) = \left(\sum_{k=1}^{NG} a_k + b_k P_{Gk} + c_k P_{Gk}^2 \right) \quad (29)$$

where, a_k , b_k and c_k represents cost coefficients of the k^{th} generator unit.

Generator units of total fuel cost minimization with valve effect in practical and accurate model multiple valve steam turbines incorporates is represented by Eq.(29) [15], [26].

$$G_{FC}(P_G) = \left(\sum_{k=1}^{NG} F_k(P_{Gk}) \right) = \sum_{k=1}^{NG} a_k + b_k P_{Gk} + c_k P_{Gk}^2 + d_k \times \sin\{e_k \times PGkmin - PGk\} \quad (30)$$

Where, d_k and e_k are cost coefficients of fuel at k^{th} generator unit.

(b) Transmission loss minimizing: The mathematical formulation of transmission loss minimizing is represented by Eq.(31)

$$\text{Minimization } TP_{loss} \quad (31)$$

where, TP_{loss} is the total transmission line power loss mathematically, represented by Eq.(32)

$$TP_{loss} = \sum_{k=1}^{NTL} G_k [V_k^2 + V_l^2 - 2|V_k| |V_l| \cos(\delta_k - \delta_l)] \quad (32)$$

where, G_k is the conductance of the k^{th} line connected between k^{th} to l^{th} buses.

(c) Emission minimizing: Mathematical representation of generator emission Minimizing is given by Eq.(33) [23].

$$\text{Minimization } E(P_G) \quad (33)$$

where, $E(P_G)$ is total generator emission.

In wide-ranging varieties, generators emit the nitrogen oxides (NO_x) and sulfur oxides (SO_x) pollutants into the atmosphere. It is separately modeled and expressed by Eq.(34)[27].

$$E(P_G) = \sum_{k=1}^{NG} (\alpha_k + \beta_k P_{Gk} + \gamma_k P_{Gk}^2 + \eta_k \exp(\lambda_k P_{Gk})) \quad (34)$$

Where, α_k , β_k , γ_k , η_k , and λ_k are emission coefficients.

(d) Combined economic and environmental cost minimizing: The objective is to consider both cost effectiveness and emission simultaneously. Both the economic and environmental OPF problem has been converted into a problem with a single objective by introducing price penalty factor γ [23] and may be formulated as

$$\text{Min OBF } (G_{FC}, E) \quad (35)$$

where OBF (G_{FC} , E) is the combination of economic as well as environmental cost which may be represented by Eq.(33) [28].

$$\text{OF } (G_{FC}, E) = G_{FC} + \gamma \times E \quad (36)$$

The steps for calculating γ is found in [23].

4. Satin Bowerbird Optimization Algorithm(SBBOA)

Satin Bowerbirds spend their whole life time living mainly in the rain forests and mesic forests of Eastern Australia. Similar to the other bird families, they move into open places for eating food during the autumn and winter seasons. However, during breeding season, the male bird constructs bowers with special sticks by which female birds are attracted. The male with the making of the bower, decking it with decorations and

dancing around the surrounding place attracts the female [11], [29]. The other male birds steal and destroy the decorations in the bower to overcome competition[30]. Female birds visit many bowers before choosing their partner for breeding. In this SBBOA, adult male birds begin by constructing superior bowers with different materials for attracting female during mating season. Based on the life style of satin bowerbird, SBBOA is structured with various stages as following:

4.1. Generating a set of random bower

SBBOA begins with creating an initial population randomly similar to other meta-heuristic optimization algorithms. The bower position is set with the initial population. Each position is an n-dimensional vector of parameters that must optimize. These values are randomly initialized so that a uniform distribution is considered between the lower and upper limit parameters. The parameters of each bower are the same as the variables in the optimization problem. The combination of parameters determines the attractiveness of the bower.

4.2. Calculating the probability of each population member

The probability is the attractiveness of a bower. A female satin bowerbird selects a bower (built) based on its probability. Similarly, a male mimics bower building through selecting a bower based on the probability that is assigned to it. This probability is calculated by Eq. (37). In this equation, Fit_k is fitness of the k^{th} solution and NB is the number of bowers. In this equation, the value of Fit_k is achieved by Eq.(38)[11].

$$Prob_k = \frac{Fit_k}{\sum_{n=1}^{NB} fit_n} \quad (37)$$

$$Fit_k = \begin{cases} \frac{1}{1+f(x_k)}, & f(x_k) \geq 0 \\ 1 + |f(x_k)|, & f(x_k) < 0 \end{cases} \quad (38)$$

In this equation, $f(x_k)$ is the value of the cost function in k^{th} position or k^{th} bower. The cost function is a function optimized by the Eq. (38) which has two parts. The first part calculates the final fitness where values are greater than or equal to zero, while the second part calculates the fitness for values less than zero. This equation has two main characteristics such as for $f(x_k)=0$ both parts of this equation have fitness value of one and fitness value is always a positive value

4.3. Elitism

Elitism is one of the important features of evolutionary algorithms. Elitism allows the best solution (solutions) to preserve at every stage of the optimization process. All the birds normally build their nests using their natural instincts. The male satin Bowerbird like all other birds in the mating season and uses his natural instincts to build his bower and decorate it. This means that all males use materials to decorate their bowers. However, an important factor that attracts more attention to the bower of a particular male is his experience. This

experience helps a lot in both his dramatic gestures as well as his bower building. This means that older males can attract more attention than others to their bowers. In other words, experienced males build better bowers, and so these bowers have more fitness than the other bowers. In this work, the position of the best bower built by birds (best position) is intended as the elite of iteration. Since the position of the elite has the highest fitness, it should be able to influence the other positions[11].

4.4. Determining new changes in any position

In each cycle of the algorithm, new changes at any bower are calculated according to Eq.(39).

$$x_{ik}^{new} = x_{ik}^{old} + \lambda_k \left(\left(\frac{x_{jk} + x_{elite,k}}{2} \right) - x_{ik}^{old} \right) \quad (39)$$

In this equation, x_k is k^{th} bower or solution vector and x_{ik} is k^{th} member of this vector. x_j is determined as the target solution among all solutions in the current iteration. In Eq.(39), value j is calculated based on probabilities derived from positions. In fact, the value j is calculated by the roulette wheel procedure, which means that the solution having larger probability will have more chance to be selected as x_j ; x_{elite} indicates the position of the elite, which is saved in each cycle of the algorithm. In fact, position of the elite is the position of a bower whose fitness is the highest in the current iteration. The parameter λ_k determines the attraction power of the goal bower. It determines the amount of step, calculated for each variable. This parameter is determined by Eq.(40)[11].

$$\lambda_k = \frac{\alpha}{1+p_j} \quad (40)$$

In Eq. (40), α is the greatest step size and p_j is the probability obtained by Eq.(37) using the goal bower. Since the obtained probability values are between 0 and 1, the denominator of this equation is collected by 1 to avoid 0 in the denominator of the Eq.(40). As is obvious from Eq.(40), the step size is inversely proportional to the probability of target position. In other words, when the probability of the target position is greater (due to the constant α), movement to that position is more carefully done. The highest step size occurs when the probability of the target position is 0 while the step size will be α . On the other hand, the lowest step size occurs when the probability of target position is 1 and the step size is $\alpha/2$.

4.5. Mutation

When males are building a bower on the ground, they may be attacked by other animals or be completely ignored. In many cases, stronger males steal materials from weaker males or may even destroy their bowers. Therefore, at the end of each cycle of the algorithm, random changes are applied with a certain probability. In this step, random changes are applied to x_{ik} with a certain probability. Here, for mutation process, a normal distribution (N) is employed with an average of x_{ik}^{old} and variance of σ^2 , as seen in Eq.(41).

$$x_{ik}^{new} \sim N(x_{ik}^{old}, \sigma^2) \quad (41)$$

$$N(x_{ik}^{old}, \sigma^2) = x_{ik}^{old} + (\sigma \times N(0,1)) \quad (42)$$

In Eq. (42), the value of σ is a proportion of space width, as calculated in Eq.(43).

$$\sigma = z \times (var_{max} - var_{min}) \quad (43)$$

In Eq. (43), var_{max} and var_{min} are the upper and lower bounds respectively assigned to the variables. z is the percentage of the difference between the upper and lower limits and is variable[11].

4.6. Combining old population and the population obtained from changes:

At the end of each cycle, old population and the population obtained from changes are evaluated. After the evaluation, these two populations are combined and sorted (based on the values obtained from the cost function) and the new population is created according to the previously defined number, while the others are deleted[11].

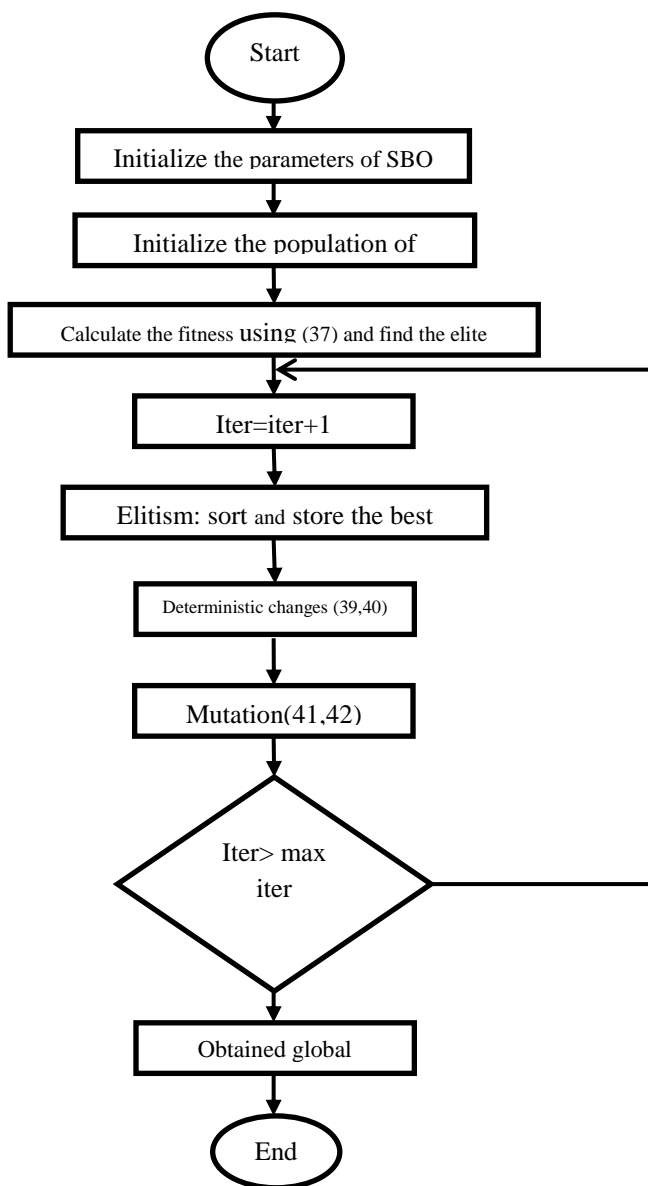

Figure 2: Flowchart of SBBOA

4.7. Pseudo code for SBBOA algorithm

Initialize the first population of bowers randomly
 Calculate the cost of bowers

Find the best bower and assume it as elite

While the end criterion is not satisfied

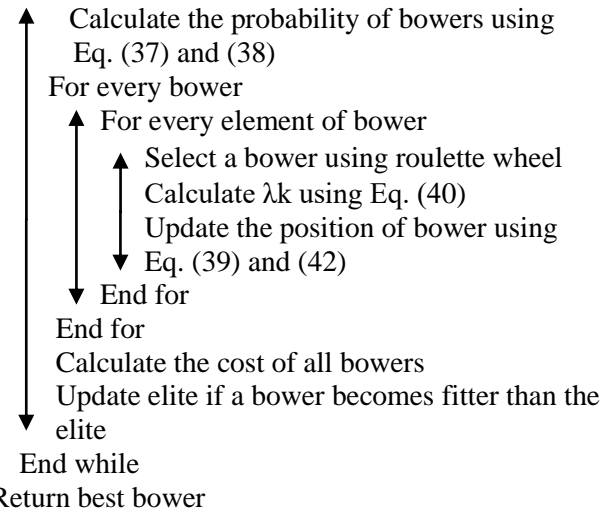

4.8. Mathematical procedure for SBBOA algorithm for OPF:

Mathematical procedure is applied to OPF problem based on the above discussion and Figure2.

Step 1: Initialize the parameters of power system (line data, bus data, fuel cost co-efficient, load flow parameters, etc.) as well as those of the proposed algorithm and specify the upper and lower limits of each individual parameter like, active power generation, generator bus voltage, load bus voltage, reactive power generation, tap changing transformers, shunt compensating devices, line flow through each transmission line and most importantly TCSC reactance and TCPS phase shift constraints etc.

Step 2: The objective function is evaluated for the bowerbird population and the best solution is stored as elite.

Step 3: Deterministic changes: The attraction power of the bower is calculated based on Eq.(37),(38) and (40). The new solution is obtained from older solution following deterministic changes (39). These new solutions are the new set of values for generation re-scheduling. The solutions implemented in the objective function, and the fitness of the solution are evaluated.

Step 4: Random changes apply to the existing solutions based on certain probability as in Eq.(41) and Eq.(42). The fitness of the obtained solution is evaluated using the objective function.

Step 5: In every iteration, the best solution is preserved as the “elite” solution. After the end of the iterations, the elite solution corresponds to the solution of the problem.

4. Implementation of SBBOA for OPF problem with FACTS

Calculation of the fitness of each element is calculated with the help of the objective function of the problem. The actual-value position of the bower has the following: active-power generation, reactive-power generation, transformer taps, generator voltages, shunt

capacitors/inductors and load bus voltages. Change is made in the actual-value position of the agents to suit the mixed variable vector and that is used to calculate the objective function value of the problem based on Newton–Raphson power flow[1].

5. Simulation test results and Discussion:

The current research work reveals, SBBOA is used to solve OPF problem on modified tests systems such as, namely IEEE-30 and IEEE-57 with FACTS units at fixed position of system which is in good agreement with findings of other researchers [28]. The prototype systems were simulated and designed using MATLAB 2018a software with 2.63 GHz and 3 GB RAM computer. In this current work, 30 experimental trails were conducted for all the simulation and the trail cases as well as the obtained results were compared and reported.

5.1 Standard IEEE-30 modified bus test system:

The standard IEEE-30 modified bus test system collective with the Six Generators, forty-one transmission lines, four transformers, nine shunt VAR units. The entire demand of the test system is 2.834 p.u. with 100 MVA base. The required information of Generators rating, Bus data, Fuel cost coefficients, and Transmission line data with limitation for the simulation purpose are taken from [31]. In this, two units of TCSC are installed in-between the lines of 3-4 and 19-20 as well as two TCPS units are installed in-between lines of 5- 7 and 10- 22[28].

(a) Minimizing fuel cost (valve point effect): As cost effectiveness is foremost in industries, minimizing Fuel cost is kept as the main objective. The Valve point loading reveals the generator input and output characteristics are non-linear. In the present work, SOS algorithm based solution of OPF problem with FACTS for fuel cost minimization is the objective of this test system. The results are then compared with recent literature namely RCGOA[28] and DEOA[28].

Table 1. Representation of the optimized control parameter settings for minimizing fuel cost with IEEE-30 modified bus test system using various algorithms (with valve point effect).

Control Parameter	RCGOA	DEOA	SOSOA	SBBOA(Proposed)
Cost, \$/h	831.03	826.54	824.21	824.14
P_{G1} , MW	198.81	199.13	200.00	199.95
P_{G2} , MW	38.96	38.32	45.00	40.44
P_{G5} , MW	19.16	20.17	15.040	19.56
P_{G8} , MW	10.64	11.43	10.000	10
P_{G11} , MW	13.56	10.43	10.08	10.08
P_{G13} , MW	12.03	12.66	12.00 0	12
P_{Gtotal} , MW	293.16	292.14	292.120	292.03
θ_{5-7} , (Degree)	-0.5713	-0.1891	-0.1824	-0.1821

θ_{10-22} , (Degree)	-0.0281	0.2177	0.2157	0.2156
Xcp_{3-4} , (p.u.)	0.0185	0.0123	0.0121	0.0120
Xcp_{19-20} , (p.u.)	0.0247	0.0250	0.0252	0.0253
Emission, (ton/h)	0.4366	0.4383	0.44369	0.44352
P_{loss} , MW	9.76	8.74	8.72	8.71.6
CT, (seconds)	714.8	505.6	500.71	500.68

RCGOA: real code genetic optimization algorithm; DEOA: differential equation optimization algorithm; SOSOA: symbiotic organism search optimization algorithm; SBBOA: Satin bowerbird optimization algorithm; CT: computational time

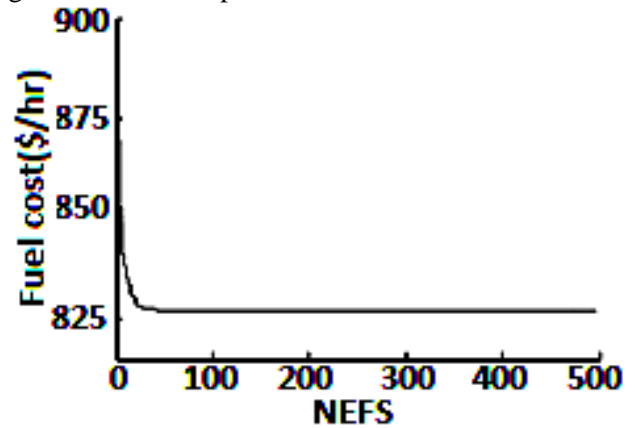

Figure 3: The plot of convergence for minimizing fuel cost with IEEE-30 modified bus test system.

From the analysis of Table 1 it is clearly shown that SBBOA based algorithm gives the minimum fuel cost as 824.14 \$/h, which is economically the least when compared to other algorithms reported in literature[28]. Illustration of the plot based on SBBOA has a convergence of fuel cost (\$/h) for this test system which is as shown in Figure 3.

(b) Minimizing Transmission line loss: Transmission line loss in a power system increases the operating cost and subsequently increases the electricity tariff. Hence, optimal control parameter settings are required to minimize the objective function of transmission line loss for this particular test system. The results of the proposed SBBOA are tabulated in Table 2. In this table, SBBOA based outcomes are compared to other recently applied optimization techniques which were reported in the literature namely RCGOA and DEOA[28].

Table 2. Representation of the optimized controlparameter settings for minimizing of active-power loss in transmission lines with IEEE-30 modified bus test system given by various optimization algorithms.

Control Parameter	RCGOA	DEOA	SOSOA	SBBOA(Proposed)
Cost, \$/h	985.21	992.30	992.24	992.23
P_{G1} , MW	77.58	74.59	74.685	76.71
P_{G2} , MW	69.58	67.30	67.450	68.34
P_{G5} , MW	49.98	50.00	50.00	49.99
P_{G8} , MW	34.96	34.85	34.430	34.98
P_{G11} , MW	23.69	27.04	27.180	24.03
P_{G13} , MW	30.43	32.36	32.380	32.01
P_{Gtotal} , MW	286.22	286.14	286.125	286.06
δ_{5-7} , (Degree)	-0.5347	-0.5329	-0.5326	-0.5325
δ_{10-22} , (Degree)	-0.0292	-0.4526	-0.4520	-0.4518
X_{cp3-4} , (p.u.)	0.0193	0.0084	0.0082	0.0081
$X_{cp19-20}$, (p.u.)	0.0239	0.0045	0.0045	0.0045
Emission, (ton/h)	0.2144	0.2109	0.210944	0.21093
P_{loss} , MW	2.82	2.74	2.725	2.724
CT, (seconds)	711.7	497.4	485.2	485.12

RCGOA: real code genetic optimization algorithm; DEOA: differential equation optimization algorithm; SOSOA: symbiotic organism search optimization algorithm; SBBOA: Satin bowerbird optimization algorithm; CT: computational time

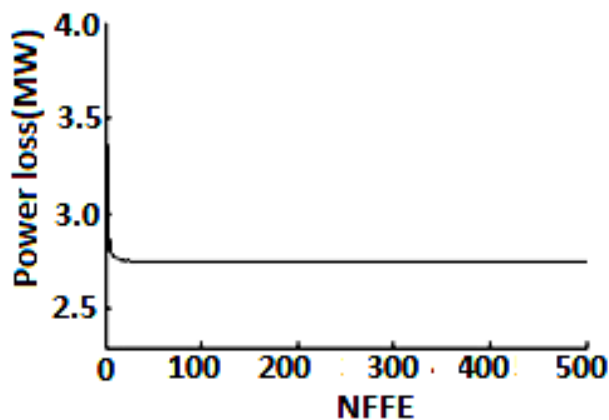

Figure 4: The plot of convergence for minimizing of power loss using IEEE-30 modified bus test system.

In the proposed method, the real-power loss obtained with the help of this test system is found to be **2.721 MW**. It is the optimum value, when compared to other techniques. It also satisfies all the constraints of the system. In Figure 4, is shown the plot of power loss convergence.

(c) **Minimizing Emission:** During power generation using fossil fuels, there is an emission of polluting gases. It causes severe impact on environment as well as on living creatures in the earth. Hence, in this work,

consideration of minimizing emission is one of the main objective functions. The optimal control parameter values obtained are produced in Table 3 along with the values obtained using other techniques as reported in the literature namely DEOA[28],RCGOA[28] and SOSOA[17]. The analysis of the results obtained shows that emission produced by proposed SBBOA is 0.204747ton/h. It is very less when compared with the results reported in other research articles. In the graphical illustration Figure 5, is shown the near optimal value of emission (ton/h).

Table 3. Representation of the optimized controlparameter settings for minimizing of emission of IEEE-30 modified bus test system given by various optimization algorithms.

Control Parameter	RCGOA	DEOA	SOSOA	SBBOA(Proposed)
Cost, \$/h	1015.80	1015.10	1014.40	1012.10
P_{G1} , MW	63.98	63.50	64.340	63.45
P_{G2} , MW	67.75	67.92	67.080	68.04
P_{G5} , MW	50.00	50.00	50.000	50
P_{G8} , MW	35.00	35.00	35.000	35
P_{G11} , MW	29.96	30.00	30.000	29.8
P_{G13} , MW	40.00	40.00	40.000	40
P_{Gtotal} , MW	286.69	286.42	286.420	286.29
δ_{5-7} , (Degree)	-0.5518	-0.5478	-0.5417	-0.5464
δ_{10-22} , (Degree)	-0.0288	0.029	0.0285	0.0282
X_{cp3-4} , (p.u.)	0.0192	0.0187	0.0183	0.0185
$X_{cp19-20}$, (p.u.)	0.0246	0.0251	0.0248	0.0246
Emission,(ton/h)	0.2049	0.2048	0.204756	0.204747
P_{loss} , MW	3.29	3.02	3.020	3.014
CT, (seconds)	707.6	511.3	501.2	501

RCGOA: real code genetic optimization algorithm; DEOA: differential equation optimization algorithm; SOSOA: symbiotic organism search optimization algorithm; SBBOA: Satin bowerbird optimization algorithm; CT: computational time

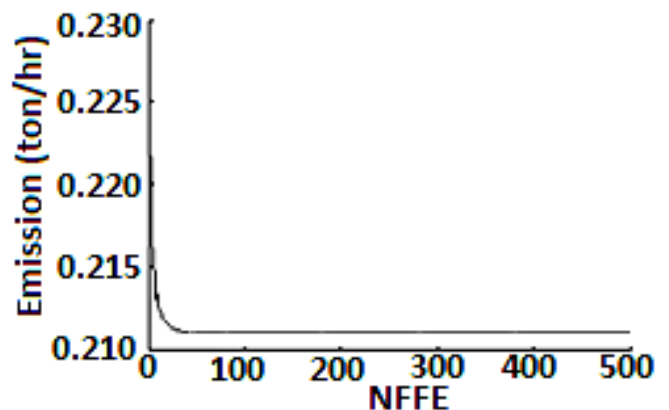

Figure 5: The plot of convergence for minimizing emission with IEEE-30 modified bus test system.

(d) Minimizing Fuel cost (without valve point):The power production has been done in an economical mode without valve-point effect taken and presented in Table 4. In this test system, the generation of real-power for the solution of OPF with FACTS devices is installed to minimize the fuel cost (without valve point effect). By the values recorded in Table 4 it is demonstrated that the proposed SBBOA shows the reduction of fuel cost as 7.19 \$/h, 0.64 \$/h and 0.09 \$/h as compared to RCGOA[28], DEOA[28], and SOSOA[17] techniques. Figure 6, is an illustration of the convergence of fuel cost (\$/h).

Table 4. Representation of the optimized controlparameter settings for minimizing fuel cost (without valve point effect) of IEEE-30 modified bus test system given by various optimization algorithms.

Control Parameter	RCGOA	DEOA	SOSOA	SBBOA(Proposed)
Cost \$/h	803.84	797.29	796.74	796.65
P_{G1} MW	192.46	180.26	186.40	184.34
P_{G2} MW	48.38	49.32	46.23	46.45
P_{G5} MW	19.54	20.82	20.54	19.67
P_{G8} MW	11.60	17.61	14.34	17.9
P_{G11} MW	10.00	11.05	11.57	11.07
P_{G13} MW	12.00	12.69	12.68	12.28
P_{Gtotal} MW	294.00	291.75	291.76	291.71
δ_{5-7} (Degree)	1.9137	-0.5558	-0.5517	-0.5501
δ_{10-22} (Degree)	0.8251	-0.0286	-0.0276	-0.0266
X_{cp3-4} (p.u.)	0.0200	0.0190	0.0191	0.0291
$X_{cp19-20}$ (p.u.)	0.0200	0.0243	0.0240	0.0230
Emission(ton/h)	NG	0.3756	0.393843	0.393834
P_{loss} MW	10.60	8.35	8.360	8.362
CT(s)	265.8	487.3	482.1	480.8

RCGOA: real code genetic optimization algorithm; DEOA: differential equation optimization algorithm; SOSOA: symbiotic organism search optimization algorithm; SBBOA: Satin bowerbird optimization algorithm; CT: computational time

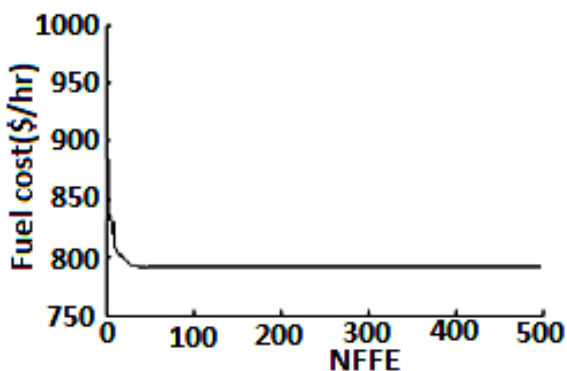

Figure 6: The plot of convergence form inimizng fuel cost (quadratic cost function) of IEEE-30 modified bus test system.

(e) Minimizing Combined emission and Fuel cost: The pollutants emitted from the power generation stations affect the environment. Ill-effects such as air pollution, noise pollution, global warming are caused. Finding a solution for curtailing those effects may result in additional cost. So it is necessary during operation to bring down fuel cost along with the minimizing of emission. The best solution to OPF problem with FACTS has been yielded by the SBBOA for minimizing both the cost as well as the ill-effects on environment. The obtained controlled parameters of fuel cost and emission are tabulated in Table 5. From the table, it is analysed that the reduction in fuel cost is 1.447 \$/h and 5.741 \$/h when compared to the reduction reported by SOSOA and DEOA as given in literature[17], [28]by using SBBOA algorithm. Figure 7 shows the graphical representation of a good convergence profile of minimized combined emission and fuel cost obtained by SBBOA. And it has reached a near optimal solution.

Table 5. Representation of the optimized controlparameter settings for minimizing of combined emission and fuel cost of IEEE-30 modified bus test system given by various optimization algorithms.

Control Parameter	DEOA	SOSOA	SBBOA(Proposed)
Cost, \$/h	1238.099	1233.805	1232.358
P_{G1} , MW	107.98	118.230	110.77
P_{G2} , MW	58.57	55.570	57.57
P_{G5} , MW	32.38	31.900	30.44
P_{G8} , MW	27.61	26.540	28.73
P_{G11} , MW	29.51	22.87	26.8
P_{G13} , MW	33.27	34.210	34.04
P_{Gtotal} , MW	289.32	289.320	288.35
δ_{5-7} , (Degree)	0.6131	0.6129	0.6126
δ_{10-22} , (Degree)	-0.0745	-0.0741	-0.0743
X_{cp3-4} , (p.u.)	0.0024	0.0022	0.0023
$X_{cp19-20}$, (p.u.)	0.0170	0.0165	0.0164
Emission, (ton/h)	0.2364	0.246647	0.248355
P_{loss} , MW	5.92	5.920	5.920
CT, (seconds)	521.9	510.7	510.6

RCGOA: real code genetic optimization algorithm; DEOA: differential equation optimization algorithm; SOSOA: symbiotic organism search optimization algorithm; SBBOA: Satin bowerbird optimization algorithm; CT: computational time

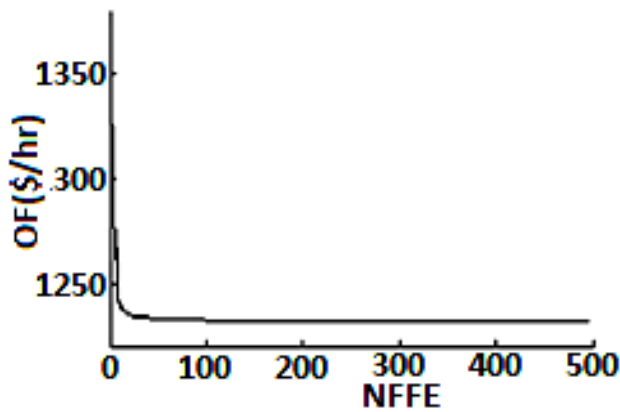

Figure 7: The plot of convergence for minimizing combined environmental and economic cost of standard IEEE-30 modified bus test system.

6. Conclusion

A newly designed meta-heuristic algorithm with Satin Bowerbird optimization SBBOA is proposed which is specifically developed to deal with the OPF problem of modified IEEE-30 test systems equipped with FACTS units. It is formulated as a nonlinear optimization problem with equality and inequality constraints of the system. This study is proposed with the objective functions of minimizing the fuel cost, minimizing active power loss during transmission, reduction of emission and minimizing the combination of economic and environmental cost each dealt in detail independently. The proposed SBBOA strategy for solving OPF problems is attained by utilizing modified IEEE-30 bus test systems with installed TCSC and TCPS at predetermined locations. The obtained results are then compared with the results of other recently applied techniques reported in the literature. It is found that of all the methods so far studied, SBBOA has aced out in all the experiments of the OPF issue with FACTS units. Consequently, the proposed SBBOA might be prescribed as the best method in dealing with other mind boggling engineering optimization issues for the future analysts.

References

- [1] H. H. Happ and K. a. Wirgau, "A review of the Optimal Power Flow," *J. Franklin Inst.*, vol. 312, no. 3–4, pp. 231–264, 1981.
- [2] J. A. Momoh, M. E. El-Hawary, and R. Adapa, "A review of selected optimal power flow literature to 1993 part i: nonlinear and quadratic Programming Approaches," *IEEE Trans. Power Syst.*, vol. 14, no. 1, pp. 96–103, 1999.
- [3] D. I. Sun, B. Ashley, B. Brewer, A. Hughes, and W. F. Tinney, "Optimal power flow by Newton approach," *IEEE Trans. Power Appar. Syst.*, vol. PAS-103, no. 10, pp. 2864–2880, 1984.
- [4] B. Stott and E. Hobson, "Power System Security Control Calculations Using Linear Programming, Part I," *Power Appar. Syst. IEEE Trans.*, vol. 75, no. 5, pp. 1713–1720, 1978.
- [5] A. M. Sasson, "Decomposition Techniques Applied to the Nonlinear Programming Load-Flow," *IEEE Trans. Power Appar. Syst.*, vol. PAS-89, no. 1, pp. 78–82, 1970.
- [6] N. Nabona and L. L. Freris, "Optimisation of economic dispatch through quadratic and linear programming," *Electr. Eng. Proc. Inst.*, vol. 120, no. 5, pp. 574–580, 1973.
- [7] B. V. Rao, G. V. N. Kumar, R. V. S. L. Kumari, and N. G. S. Raju, "A fast algorithm for power system optimization problems using an interior point method," *2011 Int. Conf. Power Energy Syst.*, vol. 7, no. 2, pp. 1–6, 1991.
- [8] A. A. El-Fergany and H. M. Hasanien, "Single and Multi-objective Optimal Power Flow Using Grey Wolf Optimizer and Differential Evolution Algorithms," *Electr. Power Components Syst.*, vol. 43, no. 13, pp. 1548–1559, 2015.
- [9] H. R. E. H. Boucekara, M. A. Abido, A. E. Chaib, and R. Mehasni, "Optimal power flow using the league championship algorithm: A case study of the Algerian power system," *Energy Convers. Manag.*, vol. 87, pp. 58–70, 2014.
- [10] M. A. Abido, "Optimal power flow using particle swarm optimization," *Int. J. Electr. Power Energy Syst.*, vol. 24, no. 7, pp. 563–571, 2002.
- [11] J. Chintam and M. Daniel, "Real-Power Rescheduling of Generators for Congestion Management Using a Novel Satin Bowerbird Optimization Algorithm," *Energies*, vol. 11, no. 1, p. 183, 2018.
- [12] M. Rezaei Adaryani and A. Karami, "Artificial bee colony algorithm for solving multi-objective optimal power flow problem," *Int. J. Electr. Power Energy Syst.*, vol. 53, no. 1, pp. 219–230, 2013.
- [13] J. Reddy Chintam, V. Geetha, and D. Mary, "Magnetotactic Bacteria Moment Migration Optimization Algorithm for Generators Real-Power Rescheduling in Deregulated Power System," *J. Comput. Theor. Nanosci.*, vol. 15, pp. 1461–1470, 2018.
- [14] J. R. Cintam, D. Mary, P. Thanigaimani, and P. Salomipuspharaj, "A zonal congestion management using hybrid evolutionary firefly (HEFA) algorithm," *Int. J. Appl. Eng. Res.*, vol. 10, no. 19, 2015.
- [15] J. R. C. S. Vinodini, "Real and Reactive Power Rescheduling for Zonal Congestion Management with Facts Devices using Symbiotic Organism Search (SOS) and Biogeography-Based Krill Herd (BBKH) Algorithm," *Jour Adv Res. Dyn. Control Syst.*, vol. 10, no. 09, pp. 210–227, 2018.
- [16] A. Mukherjee and V. Mukherjee, "Solution of optimal power flow with FACTS devices using a novel oppositional krill herd algorithm," *Int. J. Electr. Power Energy Syst.*, vol. 78, pp. 700–714, 2016.
- [17] D. Prasad and V. Mukherjee, "A novel symbiotic organisms search algorithm for optimal power flow of power system with FACTS devices," *Eng.*

- Sci. Technol. an Int. J., vol. 19, no. 1, pp. 79–89, 2016.
- [18] J. R. C. and D. D. Mary, “Optimal Relocating of Compensators for Real-Reactive Power Management in Distributed Systems,” *J Electr Eng Technol*, vol. 13, pp. 1921–718, 2018.
- [19] S. H. Samareh Moosavi and V. Khatibi Bardsiri, “Satin bowerbird optimizer: A new optimization algorithm to optimize ANFIS for software development effort estimation,” *Eng. Appl. Artif. Intell.*, vol. 60, pp. 1–15, 2017.
- [20] N. G. Hingorani, “Power electronics in electric utilities: role of power electronics in future power systems,” *Proc. IEEE*, vol. 76, no. 4, pp. 481–482, 1988.
- [21] X.-P. Zhang, C. Rehtanz, and B. Pal, *Flexible AC Transmission Systems: Modelling and Control*, 2nd ed. Berlin, Heidelberg: Springer Berlin Heidelberg, 2012.
- [22] W. Ongsakul and P. Bhasaputra, “Optimal power flow with FACTS devices by hybrid TS/SA approach,” *Int. J. Electr. Power Energy Syst.*, vol. 24, no. 10, pp. 851–857, 2002.
- [23] P. K. Roy, S. P. Ghoshal, and S. S. Thakur, “Combined economic and emission dispatch problems using biogeography-based optimization,” *Electr. Eng.*, vol. 92, no. 4–5, pp. 173–184, 2010.
- [24] A. Bhattacharya and P. K. Chattopadhyay, “Application of biogeography-based optimisation to solve different optimal power flow problems,” *IET Gener. Transm. Distrib.*, 2011.
- [25] A. Bhattacharya and P. K. Roy, “Solution of multi-objective optimal power flow using gravitational search algorithm,” *IET Gener. Transm. Distrib.*, 2012.
- [26] B. Shaw, V. Mukherjee, and S. P. Ghoshal, “A novel opposition-based gravitational search algorithm for combined economic and emission dispatch problems of power systems,” *Int. J. Electr. Power Energy Syst.*, 2012.
- [27] A. Chatterjee, S. P. Ghoshal, and V. Mukherjee, “Solution of combined economic and emission dispatch problems of power systems by an opposition-based harmony search algorithm,” *Int. J. Electr. Power Energy Syst.*, vol. 39, no. 1, pp. 9–20, 2012.
- [28] M. Basu, “Multi-objective optimal power flow with FACTS devices,” *Energy Convers. Manag.*, 2011.
- [29] S. W. Coleman, G. L. Patricelli, and G. Borgia, “Variable female preferences drive complex male displays,” *Nature*, vol. 428, no. 6984, pp. 742–745, 2004.
- [30] G. Borgia, “Bower destruction and sexual competition in the satin bowerbird (*Ptilonorhynchus violaceus*),” *Behav. Ecol. Sociobiol.*, vol. 18, no. 2, pp. 91–100, 1985.
- [31] O. Alsac and B. Stott, “Optimal Load Flow with Steady-State Security,” *IEEE Trans. Power Appar. Syst.*, vol. PAS-93, no. 3, pp. 745–751, 1974.