

# IMPLEMENTATION OF HARMONICS POWER FACTOR METER USING FUZZY LOGIC

**Dr.D.KAVITHA**

Department of Electrical & Electronics Engineering, Thiagarajar college of Engineering, Madurai

Email : dkavitha@tce.edu

**Abstract-** *In linear load conditions, power factor definition is unique. However increased use of power electronic devices, adjustable speed drives, and other nonlinear loads, causes the voltage and current waveforms to become non sinusoidal and highly distorted. In such a situation, different power factors are proposed. In this paper a new fuzzy based harmonics power factor (FHPF) meter is introduced to represent these power factors as a single index. The proposed harmonics power factor amalgamates the recommended PQIs, such as displacement power factor, transmission efficiency power factor and oscillation power factor. The FHPF was applied to non linear load with different distortion cases under, sinusoidal and non sinusoidal conditions. Considering the advantages of the fuzzy systems such as simplicity, ease of application, flexibility, speed and ability to deal with imprecision and uncertainties, this factor can be useful for power quality evaluation, cost-effective analysis of PQ mitigation techniques and billing purposes. It is shown that the new FHPF is expressive and accurately represents the existing power quality indices in all cases and in all situations. MATLAB simulations are performed. A hardware prototype of FHPF meter is developed using PIC. The current and voltage signals are sampled and the different power factors are calculated. Fuzzy logic coding is done and using a LCD, the index is displayed. The results are promising for implementation.*

**Index Terms**—harmonics, Power factor, Fuzzy logic, PIC microcontroller

## I. INTRODUCTION

Power Factor is a measure of system electrical efficiency. The significance of *power factor* lies in the fact that utility companies supply customers with volt-amperes, but bill them for watts. The classical definitions of apparent power and power factor work well as long as the loads are linear and the source voltage waveform is sinusoidal. This power factor can be used as a measure of the efficiency of the utilization of the equipment, efficiency of power transmission and oscillatory characteristics of power transfer. The consumer units in distribution systems have inductive and nonlinear characteristics. These non

linear loads inject harmonic currents of several orders into utility electric system leading to non sinusoidal situations[1-3] Here power factor calculated as a ratio of active power to apparent power cannot handle the above said properties at the same time. The proposal for various power factors such as displacement power factor, transmission efficiency power factor and oscillation power factor were given. To characterize power transfer efficiency and power oscillations in distorted voltage and current, transmission efficiency power factor and oscillation power factor were defined. Also there arise a need for alternative definitions of apparent power and power factor under harmonic conditions [4-8]. Therefore non sinusoidal Situations has recommended separating the fundamental current and voltage components from the harmonic components in order to calculate the fundamental apparent power and subsequently the displacement power factor to facilitate applying engineering economic techniques, such as power factor correction[9-12] . This also allows monitoring the fundamental power content separately from harmonic power content. Power factor is fundamentally an index of the quality of power that allows a user in a deregulated market to select an electricity provider on the basis of level of quality of the delivered power. As a result, there is a need to evaluate the quality of the power delivered through evaluating a power factor index.

Fuzzy system methodology has been demonstrated to allow solving uncertain and vague problems[13-14]. Hence a fuzzy logic based representative quality power factor is introduced[15]. This power factor index is evaluated as a single value that represents the three power factors identified earlier, namely the displacement, transmission efficiency, and oscillation power factors. Various soft computing techniques such as fuzzy logic, ANFIS were used for this evaluation. The simulation results using those techniques proved the effectiveness of the methodologies[16]. But, simulation didn't promise the practical usage of the idea. In this paper, simulations and a practical implementation of fuzzy-logic-based approach is proposed to calculate the FHPF using Mamdani's fuzzy inference mechanism (FIM). The proposed approach is tested for linear and nonlinear loads supplied from sinusoidal and/or non sinusoidal sources while considering

lagging and leading power factor. The proposed fuzzy logic based harmonic power factor meter can successfully be applied for evaluating the power quality while considering distorted waveforms.

This paper briefs the power factor concepts used, details the fuzzy inference system used for implementing the fuzzy harmonic power factor meter, simulations using MATLAB, hardware prototype development and conclude with the merits of the proposed meter.

## II. POWER FACTOR AND DEFINITIONS

Power factor is a measure of how efficiently electrical power is consumed. It is an indicator of the health or efficiency of the power distribution system. Let the voltage and current be given by

$$v(t) = \sqrt{2}v_{rms} \sin(\omega t) \quad (1)$$

$$i(t) = \sqrt{2}i_{rms} \sin(\omega t + \phi) \quad (2)$$

The active power is defined as the useful power transferred from the source to the load. This is the electric power that performs the useful work. It is what turns on the lights, causes motors to rotate or produces heat in a resistive element. Real power occurs when the current and voltage are sinusoidally varying in phase, peaking and crossing zero at the same time. Real power is measured in watts or kilowatts and billed by the kilowatt-hour. The active power is equal to,

$$P = v_{rms} i_{rms} \cos(\phi) \quad (3)$$

The apparent power is defined as the maximal active power that can be transmitted for the given rms value (or magnitude) of the voltage and given rms value (or magnitude) of the current. It can be expressed as,

$$S = v_{rms} i_{rms} \quad (4)$$

The power factor is then defined as the ratio,

$$PF = P/S \quad (5)$$

Willems[8] proposed separate definitions for the apparent power and the power factor to characterize the power transmission efficiency and the power oscillations. He defined the transmission efficiency power factor as

$$TEPF = \frac{P}{S} \quad (6)$$

Here, P and S are the active and apparent power as defined in (3) and (4). Willems also defined the oscillation power factor as

$$OSCPF = \frac{TEPF}{\sqrt{\frac{1}{2} + TEPF^2}} \quad (7)$$

Note that the maximum value of the oscillation power factor is 0.816 and occurs in case of pure resistive load which explains the unavoidable oscillation even in the sinusoidal situation while the minimum value is zero which occurs in case of the pure reactive element where there is continuous oscillation with zero average or active power. Another important power factor that is useful for monitoring separately the fundamental power from the harmonic power as well as easily applying in many engineering economic techniques such as power factor correction was recommended by the IEEE Working Group in [6]. They recommended the separation of the fundamental power components from the non-fundamental components and hence calculating the fundamental active and fundamental apparent power. The displacement power factor is defined by the ratio

$$DPF = P_1/S_1 \quad (8)$$

## III. FUZZY INFERENCE SYSTEM FOR FHPF METER

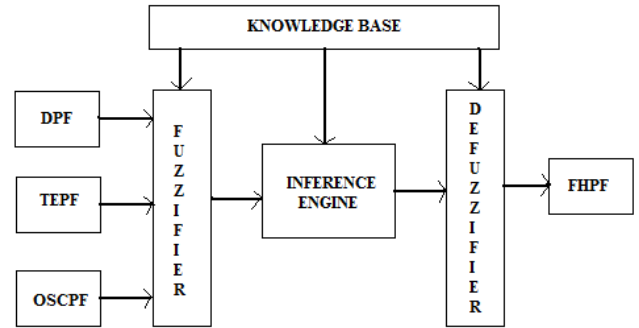

**Figure 1: Schematic diagram of Fuzzy logic based Harmonic power factor meter inference system**

The concept of fuzzy logic was well established[13]. This section explains the fuzzy logic based approach utilized to calculate the fuzzy representative quality power factor (FNSPF) which is a single value that represents an amalgamation of the existing power factors, DPF, TEPF, OSCPF. Figure 1 shows the Schematic diagram of Fuzzy logic based Harmonic power factor meter inference system. The inputs to the RQPF module are the displacement power factor dPF, transmission efficiency power factor (TEPF), and oscillation power factor (OSCPF). The values of the displacement power factor and transmission efficiency power factor range

between 0 and 1 while those of the oscillation power factor range between 0 and 0.816. Triangular form for the membership functions is used due to its simplicity to represent the variables. Three linguistic variables, Low (L), Medium (M), and High (H) are used to represent the input variables. The output is the FHPF which is represented by seven linguistic variables. They are Low (L), Moderately Low (ML), Somewhat Low (SL), Medium (M), Somewhat High (SH), Moderately High (MH), and High (H). Figure. 2 shows the representation of the input and output using linguistic variables.

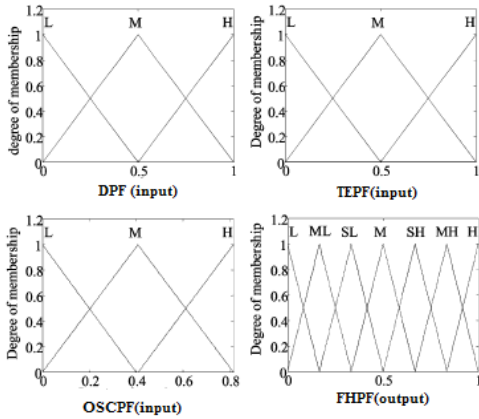

**Figure 2: Input and output fuzzification. DPF:Displacement power factor, TEPF:Transmission efficiency power factor. OSCPF:Oscillation power factor, FHPF:Fuzzy Harmonic power factor.**

There are three inputs that are each represented by three linguistic variables. Therefore we have 27 rules in the FHPF module.

Fuzzy inference rules used are listed in Table 1.

**Table 1 Fuzzy inference rules**

S.No	DP	TEPF	OSCPF	FHPF
1	L	L	L	L
2	L	L	M	ML
3	L	L	H	SL
4	L	M	L	ML
5	L	M	M	SL
6	L	M	H	M
7	L	H	L	SL
8	L	H	M	M
9	L	H	H	SH
10	M	L	L	ML
11	M	L	M	SL

12	M	L	H	M
13	M	M	L	SL
14	M	M	M	M
15	M	M	H	SH
16	M	H	L	M
17	M	H	M	SH
18	M	H	H	MH
19	H	L	L	SL
20	H	L	M	M
21	H	L	H	MH
22	H	M	L	M
23	H	M	M	SH
24	H	M	H	MH
25	H	H	L	MH
26	H	H	M	MH
27	H	H	H	H

Mamdani's fuzzy inference mechanism (FIM) that is used here, is commonly used, in which the implication part is modeled by means of the minimum operator while the aggregation part is processed using the maximum operator. There are many defuzzification techniques in the literature. Here the centroid method is used for defuzzification. This method returns the center of area under the curve that results from the aggregation process. Hence this method also called as center of area (COA) or center of gravity (COG) method is preferred. For given values of the displacement power factor, transmission efficiency power factor, and oscillation power factor, the fuzzy inference system module will calculate the fuzzy harmonic power factor.

#### IV. SIMULATIONS AND RESULTS

The FIS is applied to different test cases that include linear and nonlinear loads supplied from sinusoidal and non sinusoidal sources. The different conditions taken and studied are:

1. Linear load supplied from sinusoidal source.
2. Linear load supplied from Non Sinusoidal Source.
3. Non linear Load Supplied From Sinusoidal Source.
4. Non linear Load Supplied From Non Sinusoidal Source. Figure 3 shows a circuit simulated that consists of load supplied from a through a line having an impedance of  $5+j5\Omega$ . The source voltage has the rms voltage of 230 volts and the frequency is 50Hz. The load voltage and the load current are used to calculate the displacement power factor, oscillation power factor, transmission power factor. For non sinusoidal sources, in addition to the fundamental component, harmonics components are added. For non linear load, the diode having snubber resistance of 500

ohms and snubber capacitance of 250 nF is connected with linear load. Using the proposed fuzzy based harmonic power factor module, the value of the Fuzzy Harmonic power factor can be obtained. Table 2 lists the seven different cases considered.

**Table 2 Cases considered for FHPF Evaluation**

Case	R <sub>load</sub> in ohms	X <sub>load</sub> in
1	1	0
2	0	20
3	0	5
4	20	20
5	20	113
6	20	5
7	20	-20

Seven cases are considered for FHPF evaluation and their results under above stated four conditions are given in Table 3 to 6.

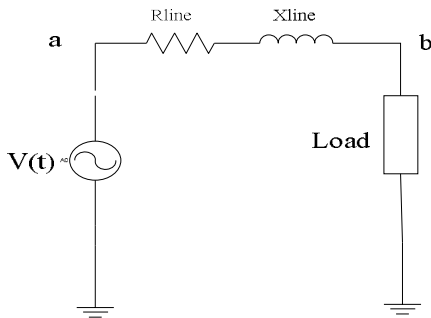

**Figure 3 Linear loads supplied from sinusoidal or non sinusoidal source**

**Table 3 Simulation Result for Linear Loads under Sinusoidal Source**

Case	DPF	TEPF	OSCPF	FHPF
1	1	1	0.82	1
2	0	0	0	0
3	0	0	0	0
4	0.7	0.7	0.71	0.71
5	0.2	0.25	0.331	0.3
6	0.97	0.97	0.81	0.93
7	0.7	0.7	0.7	0.71

**Table 4 Simulation Result for Linear Loads under Non Sinusoidal Source**

Case	DPF	TEP	OSCPF	FHPF
1	1	1	0.8	1
2	0	0	0	0
3	0	0	0	0
4	0.7	0.53	0.6	0.67
5	0.2	0.13	0.18	0.28
6	1	0.58	0.63	0.77
7	0.7	0.54	0.61	0.68

**Table 5 Simulation Result for Non Linear Loads under Sinusoidal Source**

Case	DPF	TEPF	OSCPF	FHPF
1	1	0.62	0.65	0.8
2	0.3	0.02	0.03	0.2
3	0.6	0.02	0.03	0.25
4	0.8	0.5	0.58	0.7
5	0.4	0.24	0.32	0.38
6	0.95	0.59	0.64	0.78
7	0.8	0.5	0.58	0.7

**Table 6 Simulation Result for Non Linear Loads under Non Sinusoidal Source**

Case	DPF	TEPF	OSCPF	FHPF
1	1	0.6	0.65	0.8
2	0.48	0.03	0.04	0.2
3	0.87	0.03	0.04	0.32
4	0.92	0.52	0.59	0.66
5	0.58	0.29	0.37	0.4
6	1	0.6	0.65	0.78
7	0.96	0.52	0.59	0.68

It is noted from the results that for the first case, first two conditions shows FHPF as 1 indicating the absence of reactive power as well as harmonics in the supply as well as load. The third and fourth condition of the same case shows reduced FHPF of 0.8 due to the presence of non linear loads. Thus this index reduces by identifying the presence of devices through which consumer injects harmonics. In the next two cases, there is no real power usage of customer as R component is 0, FHPF is 0 for the first two conditions but is increased up to 0.3 in case of third and fourth

condition and this is due to the presence of non linear loads. Except seventh case, all power factors are lagging. Fourth, fifth and sixth case is the study of presence of both R and X terms in the circuit in which the FHPF increases with decrease in inductive reactance which proves the power factor theory. When comparing the DPF and FHPF, it is observed that both agree to each other in the case of linear load and sinusoidal supply case but FHPF shows reduced value if either the load is non linear or the source is non sinusoid. Thus this index is nearer to the transmission efficiency power factor and indicates a value consolidating the various power factor indices.

## V. HARDWARE IMPLEMENTATION OF THE ALGORITHM

The experimental setup of the proposed algorithm is carried out on an experimental prototype with a PIC16F877A microcontroller kit used for computation. The PIC samples the voltage and current waveform and computes the three power factors. Also it evaluates the fuzzy based harmonic power factor. The required programming is done using PICkit 2™ Programmer. PIC estimates the displacement power factor by measuring the phase angle between the voltage and current waveforms. Look up table is created for the computation of the active power and apparent power. A matlab program is developed for the calculation of active and apparent power under different load conditions with different range of harmonics in voltage and current signals. A simulation of about 800 cases are done and based on the results, look up table is formed for obtaining active and apparent powers. Transmission efficiency power factor and subsequently oscillation power factor are calculated using equation.. These three power factors are given as inputs to determine the fuzzy harmonic power factor. The block diagram of the hardware setup is given in figure. The experimental setup is provided in figure. Practical loads such as fan, driller machine, bulb load along with the experimental setup of SCR based rectifier circuits are used as a load.

### ALGORITHM FOR THE CONTROLLER SYSTEM:

1. Start the program.
2. Voltage and current samples are taken using on chip ADC of PIC16F877A.
3. Displacement power factor is found by comparing current and voltage waveform using zero crossing detectors.
4. Samples are compared with simulation values and find transmission efficiency (t) power factor.
5. Find Oscillation Power factor by means of t value.
6. Compute the membership values for d, t, o by calculating slope based on membership degree.

7. For every power factor now three – LOW, MEDIUM, HIGH membership values are thus calculated.
8. The respective values are passed to the Rule base.
9. Evaluate the FHPF for all 27 rules.
10. Defuzzify FHPF based on centroid method and find crisp value.
11. Display value in LCD.

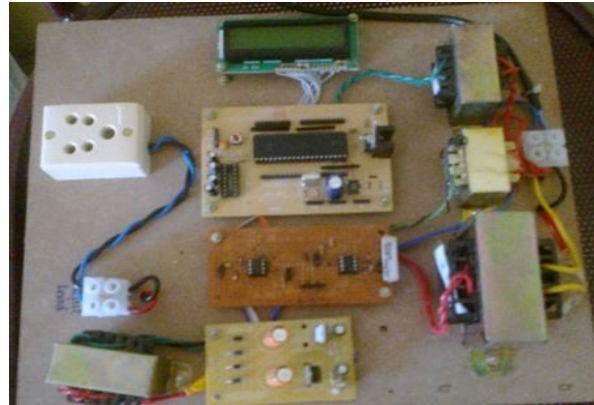

Figure 4 Hardware setup to measure FHPF

Table 7 Hardware Output

LOAD	DPF	TEPF	FHPF
FAN (230V, 0.3A)	0.78	0.65	0.700
TUBE LIGHT (230V, 0.14A)	0.880	0.99	0.897
20+j5	0.897	0.552	0.653
35+j5	0.899	0.772	0.718

## VI .CONCLUSION

Normally utilities are penalizing the customers based on the power factor values. As this power factor is not unique under harmonic conditions, neither the Utility nor the customer must suffer, due to an incorrect bill. A valid proof for satisfying the customers with the reason for which they have been penalized is also essential.

The proposed fuzzy based harmonic power factor meter is used to represent the existing different power factors—displacement power factor, transmission efficiency power factor and oscillation power factor as a single quantity. From the simulation of the proposed fuzzy based approach for calculating the representative quality power factor in linear or nonlinear loading conditions and supplied from sinusoidal or non- sinusoidal sources, considering lagging and leading power factor cases, it is

found that this factor is very expressive and accurately represents these power factors in all cases. The designed measurement device characterizes qualitatively and quantitatively the degree of electric power system utilizations by a single index, while carrying all of the characteristics of the three power factors that it represents. The index can be effective in making a cost-effective analysis for applying the power factor correction devices and power quality mitigation techniques. Since fuzzy based harmonic power factor can completely characterize the system power factors performance, this might help facilitate the comparative economic analysis which requires an estimation of the costs associated with the variations of the power factors due to disturbances and the costs of different PQ mitigation alternatives. This power factor will be useful for billing purposes, since it has proven to be very sensitive to any changes in power factor especially under non-sinusoidal operating conditions. Therefore, customers will be charged the correct amount based on the power factor maintained by them.

## VII. REFERENCES

- [1] A. E. Emanuel, "On the definition of power factor and apparent power in unbalanced polyphase circuits with sinusoidal voltage and currents," *IEEE Trans. Power Del.*, vol. 8, no. 3, pp. 841–852, Jul. 1993.
- [2] Fayçal CHABNI, Rachid TALEB, M'hamed HELAIMI, "High Order Harmonics Elimination in Modified Single Phase 5-level Cascaded H-bridge Inverter Using HGA", *Journal of Electrical Engineering*, Volume 17, no.3, 2017
- [3] P. S. Filipski, Y. Baghzouz, and M. D. Cox, "Discussion of power definitions contained in the IEEE dictionary," *IEEE Trans. Power Del.*, vol. 9, no. 3, pp. 1237–1244, Jul. 1994.
- [4] L. S. Czarnecki, "Power related phenomena in three-phase unbalanced systems," *IEEE Trans. Power Del.*, vol. 10, no. 3, pp. 1168–1176, Jul. 1995.
- [5] M. Markovska, D. Taskovski, "Efficient implementation of QMF filter bank for power harmonic analysis on digital signal processor", *Journal of Electrical Engineering*, Volume 16, no.4, 2016
- [6] "Practical definitions for power systems with nonsinusoidal waveforms and unbalanced loads: A discussion," *IEEE Trans. Power Del.*, vol. 11, no. 1, pp. 79–87, Jan. 1996.
- [7] D. Sharon, "Power factor definitions and power transfer quality in nonsinusoidal situations," *IEEE Trans. Instrum. Meas.*, vol. 45, no. 3, pp. 728–733, Jun. 1996.
- [8] J. L. Willems, "Reflections on apparent power and power factor in nonsinusoidal and polyphase situations," *IEEE Trans. Power Del.*, vol. 19, no. 2, pp. 835–840, Apr. 2004.
- [9] J. L. Willems, J. A. Ghijselen, and A. E. Emanuel, "The apparent power concept and the IEEE standard 1459-2000," *IEEE Trans. Power Del.*, vol. 20, no. 2, pt. 1, pp. 876–884, Apr. 2005.
- [10] H. Lev-Ari and A. M. Stankovic, "A decomposition of apparent power in polyphase unbalanced networks in nonsinusoidal operation," *IEEE Trans. Power Syst.*, vol. 21, no. 1, pp. 438–440, Feb. 2006.
- [11] A. Ferrero, "Definitions of electrical quantities commonly used in nonsinusoidal conditions," *Eur. Trans. Elect. Power*, vol. 8, pp. 235–240, 1998.
- [12] W. R. A. Ibrahim and M. M. Morcos, "Artificial intelligence and advanced mathematical tools for power quality applications: A survey," *IEEE Trans. Power Del.*, vol. 17, no. 2, pp. 668–673, Apr. 2002.
- [13] G. J. Klir, U. C. St, and B. Yuan, *Fuzzy Set Theory Foundations and Applications*. Upper Saddle River, NJ: Prentice-Hall PTR, 1997.
- [14] H.-J. Zimmermann, *Fuzzy Set Theory and Its Applications*, 4th ed. 2001.
- [15] Walid G, M. E. El-Hawary "A New Fuzzy-Based Representative Quality Power Factor for Nonsinusoidal Situations .," *IEEE Trans. Power Del.*, vol. 23, no. 2, pp. 930–936, April 2008.
- [16] N. RathinaPrabha a,n, N.S.Marimuthu b, C.K.Babulal," Adaptive neuro-fuzzy inference system based representative quality power factor for power quality assessment" *Neurocomputing* , 2010, 2737–2743