

Comprehensive analysis of PID and FOPID controller fed BLDC motor

P.Sureshpandiarajan^{1*}, P.Vimala², C.R.Balamurugan³, T.Sengolrajan⁴

¹Department of ECE, PSR Engineering College, Sivakasi

²Department of EEE, IFET Engineering College, Villupuram

³Department of EEE, Karpagam College of Engineering, Coimbatore, India

⁴Department of EEE, Kongunadu Engineering College, Trichy

*drcrb2005@gmail.com

Abstract-The FOPID and PID controller are designed for better control in terms of acceleration and deceleration in Brushless DC drive. The parameters k_p, k_i, k_d, λ and μ of these controller are optimized based on genetic algorithm. The optimized coefficients keep in track with zero error signals. The output of the controller is given to the variable dc source which varies the input voltage to the three phase inverter depending on the input signal. The three phase inverter gives the voltage to the BLDC motor which enhances the stability of the system. The effectiveness of the controller is demonstrated by simulation.

Keyword: PID, FOPID, BLDC motor, stability

1. Introduction

Brushless dc motor has coils at stationary part with PM at the moving part. As it does not have brushes and commutator the efficiency of the motor increases with decrease in the ohmic losses. Brushless dc motors are classified based on supply as 1Φ and 3Φ . But 3Φ configurations are commonly used. Generally, Angle of rotor location is identified using special type of sensor. But in this project the rotor position is determined from excitation current and voltage across the stator windings. The BLDC motor requires inverter as there is no brush and commutation arrangement. The inverter uses transistor for low drive application and Thyristor for high power drives. MOSFET/DIODE switches are used in the inverter. The commutation sequence to the MOSFET//DIODE depends on the rotor position. BLDC motor require less maintenance, generate less noise, have low inertia, have high efficiency, has long operating life. The proposed system will be used to have better performance. The PID and FOPID controller parameters are tuned by genetic algorithm [14], more optimization techniques are used to tune the coefficients of FOPID and PID controller [4]. In this paper the process to control is speed of the BLDC

motor. The BLDC motor is modeled [12] [5]. The FOPID controller transfer function is formed by using FOMCON toolbox [10]. The genetic algorithm optimization to tune PID and FOPID is done by using optimization toolbox.

2. Speed Control of BLDC motor

The block diagram for speed control of BLDC motor is shown in figure 1. The rotor position and speed of the Brushless dc motor is computed from the voltage and current supplied to the stator windings of BLDC motor. Each phase winding is excited in a sequence to run the Brushless dc motor. The phase winding of the Brushless dc motor is excited in a sequence by sequence commutation of the MOSFET/DIODE in the inverter.

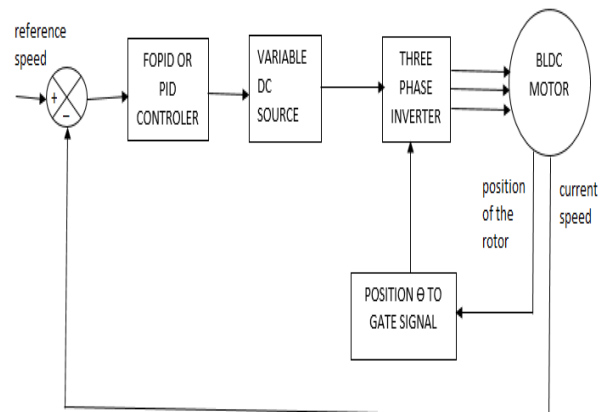

Figure 1. Block diagram of the proposed system

That switching sequence is given to the inverter from position to gate signal block as shown in figure 1. The acceleration of the proposed motor is depends on the voltage. Therefore, to control the speed of the BLDC motor, the input voltage must be controlled. The speed computed is compared with the reference speed by the comparator and the error signal is obtained. The error signal is given as input to the controller. The output of

the controller is control signal. This control signal is given as input to the variable DC source. There by the input DC voltage is controlled based on the BLDC motor speed.

2.1. PID Controller

The PID controller consists of the proportional, integral and derivative controller. The proportional controller gives proportional response of the input error value. The integral controller is proportional to magnitude and the duration of the error. It improves the settling time and decreases the difference in time. The integral term gives response which also depends on the sum of previous error values. The sum of the previous error value is multiplied with the gain k_i . The derivative control gives the slope of the error for specified duration and multiples it with the gain k_d . The sum of this proportional, integral and derivative control gives the PID controller. The control signal of PID controller in time domain.

$$u(t) = k_p e(t) + k_i \int_0^t e(t) dt + k_d \frac{de(t)}{dt} \quad (1)$$

Taking Laplace transform of above equation, the transfer function of PID controller is given by,

$$G_c(S) = \frac{U(S)}{E(S)} = k_p + \frac{k_i}{s} + k_d s \quad (2)$$

Where,

k_p is proportional gain, k_i is integral gain, k_d is derivative gain, $e(t)$ is an error signal

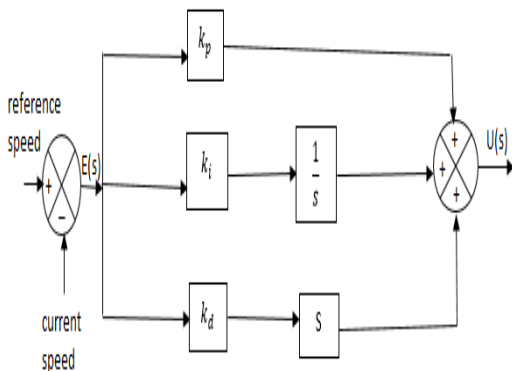

Figure. 2 Block diagram of PID controller

The block diagram of PID controller is shown in figure 2. The parameter k_p, k_i, k_d have to be tuned by

using genetic algorithm. The PID controller can implement in MATLAB/Simulink by PID block available in continuous time toolbox.

2.2. FOPID controller

Fractional order PID controller is commonly in the form $PI^\lambda D^\mu$. In this the integrator and differentiator is in the order of λ and μ . The TD representation of FOPID control signal is

$$u(t) = k_p e(t) + k_i D^{-\lambda} e(t) + k_d D^\mu e(t) \quad (3)$$

Where

$D^{-\lambda}$ - Fractional order integrator, D^μ - Fractional order differentiator

Taking Laplace transform for above equation, the TF of FOPID controller is given by

$$G_c(S) = \frac{U(S)}{E(S)} = k_p + \frac{k_i}{s^\lambda} + k_d s^\mu \quad (4)$$

Where

λ - Order of integrator, μ - Order of differentiator

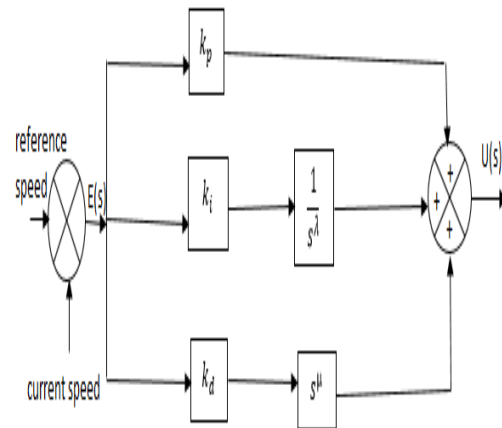

Figure. 3. Block diagram of FOPID controller

The block diagram of FOPID controller is shown in figure 3.

3. Design of BLDC motor

The rotor and shaft of the BLDC motor is assumed to be rigid. The mode is assumed as having viscous friction model. Therefore the friction torque is proportional to the shaft angular velocity. Based on Newton second law and KVL, 3Φ Y connected drive is given below with equations three phase star connected BLDC motor can be described by following equation

$$T_e = b\theta_m + J \frac{d^2\theta_m}{dt^2} + T_L \quad (5)$$

$$V_{ab} = R(i_a - i_b) + L \frac{d(i_a - i_b)}{dt} + e_a - e_b \quad (6)$$

$$V_{bc} = R(i_b - i_c) + L \frac{d(i_b - i_c)}{dt} + e_b - e_c \quad (7)$$

$$V_{ca} = R(i_c - i_a) + L \frac{d(i_c - i_a)}{dt} + e_c - e_a \quad (8)$$

Where $T_e, \theta_m, b, J, T_L, V, R, L, I, e$ are various parameters used.

The V and I equations is given by

$$V_{ab} + V_{bc} + V_{ca} = 0 \quad (9)$$

$$I_{ab} + I_{bc} + I_{ca} = 0 \quad (10)$$

To simplify the modeling, only two voltage equation are need, they are

$$2V_{ab} + V_{bc} = 3Ri_a + 3L \frac{di_a}{dt} + 2e_a - e_b - e_c \quad (11)$$

$$-V_{ab} + V_{bc} = 3Ri_b + 3L \frac{di_b}{dt} + 2e_b - e_a - e_c \quad (12)$$

The torque generated by the BLDC motor is given by

$$T_e = (e_a i_a + e_b i_b + e_c i_c) / \frac{d\theta_m}{dt} \quad (13)$$

The trapezoidal Eb is given below

$$e_a = \frac{k_e d\theta_m}{2 dt} Tra(\theta_e) \quad (14)$$

$$e_b = \frac{k_e d\theta_m}{2 dt} Tra(\theta_e - \frac{2\pi}{3}) \quad (15)$$

$$e_c = \frac{k_e d\theta_m}{2 dt} Tra(\theta_e - \frac{4\pi}{3}) \quad (16)$$

Where k_e, θ_e are the Eb fixed and electrical angle respectively.

$$\theta_e = p\theta_m$$

Tra(θ_e) is the trapezoidal waveform function

$$Tra(\theta_e) = \begin{cases} 1, & 0 \leq \theta_e < \frac{2\pi}{3} \\ 1 - \frac{6}{\pi} \left(\theta_e - \frac{2\pi}{3} \right), & \frac{2\pi}{3} \leq \theta_e < \pi \\ -1 + \frac{6}{\pi} \left(\theta_e - \frac{5\pi}{3} \right), & \frac{5\pi}{3} \leq \theta_e < 2\pi \end{cases} \quad (17)$$

Substituting (14) (15) (16) in (13) we torque as follows:

$$T_e = \frac{k_e}{2} [Tra(\theta_e)i_a + Tra\left(\theta_e - \frac{2\pi}{3}\right)i_b + Tra\left(\theta_e - \frac{4\pi}{3}\right)i_c] \quad (18)$$

The angle of the rotor and speed of the rotor is related as follows

$$w_e = \frac{d\theta_m}{dt} \quad (19)$$

$$w_e = pw_m \quad (20)$$

Where

w_e - Electrical speed, w_m - Mechanical speed

From the equation (5) and (19), we get the speed equation as

$$w_m = \frac{T_e - T_L - k_f w_m}{J_s} \quad (21)$$

From (11)

The current i_a is given as

$$i_a = \frac{2V_{ab} + V_{bc} - 2e_a + e_b + e_c - 3Ri_a}{3LS} \quad (22)$$

From (12)

$$i_b = \frac{-V_{ab} + V_{bc} - 2e_a + e_b + e_c - 3Ri_a}{3LS} \quad (23)$$

From (10)

The current i_c is given as

$$i_c = -i_a - i_b \quad (24)$$

4. Inverter topology

The inverter used here is a three phase inverter. It consists of three leg and six MOSFET/DIODE. It is implemented by using universal bridge available in toolbox. The gate signal in this universal bridge decides the MOSFET commutation. The inverter is shown in figure 4,

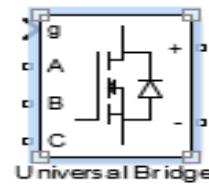

Figure 4. Three phase MOSFET/DIODE Inverter

5. System modelling

Transfer function of BLDC motor:

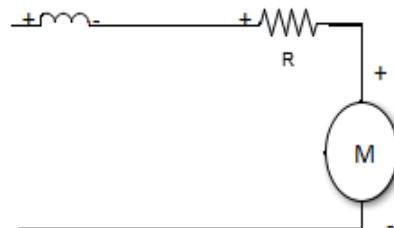

Figure 5. Circuit diagram of dc motor

Using Kirchoff's voltage law,

$$V_s = Ri + L \frac{di}{dt} + e \quad (25)$$

Where V_s , R , I , L , e are the source voltage, resistance in ohm, current to the motor, inductance of the coil, back emf respectively.

The torque is given by

$$T_e = k_f w_m + J \frac{dw_m}{dt} + T_L \quad (26)$$

Where T_e, k_f, J, w_m, T_L are the electrical torque, the friction constant, the rotor inertia the angular velocity and the supposed mechanical load respectively

The electrical torque and the Eb could be written as

$$e = k_e w_m \quad \text{and} \quad T_e = k_t w_m$$

Where k_e is back emf constant and k_t is torque constant.

From equation (25) and (26)

The transfer function for dc motor is given as

$$G(s) = \frac{w_m}{V_s} = \frac{k_t}{s^2 J L + (R J + k_f L) s + k_f R + k_e k_t} \quad (27)$$

Considering the following assumption,

1. The friction constant is small ($k_f = 0$)
2. $R J \gg k_f L$
3. $k_e k_t \gg k_f R$

And multiplying by $\frac{R}{k_e k_t} \times \frac{1}{R}$ in the equation (27)

The T.F of dc motor is given as

$$G(s) = \frac{\frac{1}{k_e}}{\tau_m \tau_e s^2 + \tau_m s + 1} \quad (28)$$

Where mechanical time constant $\tau_m = \frac{R J}{k_e k_t}$

Electrical time constant $\tau_e = \frac{L}{R}$

But for the BLDC motor

$$\tau_m = \sum \frac{R J}{k_e k_t}$$

$$\tau_e = \sum \frac{L}{R}$$

Therefore, since there is a symmetrical arrangement and a three phase the mechanical and electrical constant become,

$$\tau_m = \frac{3 R J}{k_e k_t}$$

$$\tau_e = \frac{L}{3 R} \quad (29)$$

Considering the phase effect,

$$\tau_m = \frac{3 R \phi J}{\frac{k_e (L-L)}{\sqrt{3}} k_t} \quad (30)$$

Where $k_e = \frac{k_e (L-L)}{\sqrt{3}}$

From the MAXON EC 45 FLAT BLDC motor datasheet, the value of phase resistance, phase

inductance, rotor inertia and mechanical time constant are shown in Table 1.

Table 1. MAXON EC 45 FLAT BLDC motor datasheet

Parameter	Symbol	Value	Unit
Phase resistance	R_ϕ	1.2	Ohm
Phase inductance	L	0.560	Mh
Rotor inertia	J	92.5 $\times 10^{-6}$	gcm^2
Mechanical time constant	τ_m	17.1	Ms

Substituting the above values in (29)

$$\tau_e = 155.56 \times 10^{-3}$$

From (6)

$$k_e = 0.076 \frac{v - secs}{rad}$$

Substituting the values of τ_m, τ_e, k_e in (27) we get the T.F of BLDC motor as

$$G_1(s) = \frac{13.11}{2.66 \times 10^{-6} s^2 + 0.0171 s + 1} \quad (31)$$

Transfer function of inverter:

The transfer function of the inverter is given as:

$$G_2(s) = \frac{k_{in}}{1 + s T_{in}} \quad (32)$$

Delay time $T_{in} = 0.004 \text{ sec}$

$$\text{Gain } k_{in} = \frac{2 V_{DC}}{\pi V_{cm}} = 0.65 \times \frac{200}{20} = 6.36$$

$$\text{Therefore, } G_2(s) = \frac{6.36}{1 + 0.004 s} \quad (33)$$

Finally, the T.F of the system is given by

$$G(s) = \frac{G_1(s) \times G_2(s)}{1.064 \times 10^{-08} s^3 + 7.106 \times 10^{-05} s^2 + 0.0211 s + 1} \quad (34)$$

The parameters are tuned for this system.

6. Genetic algorithm

Genetic algorithm is an optimization technique. This technique is used to tune the parameter of PID and FOPID controller. The flowchart of the genetic algorithm is shown in figure 6. It is an iterative process with the population in each iteration called a generation. First the initial population is generated. The population may range from hundred to thousand. From the population the fitness solution to each

individual is chosen by objective function. In the selection process the portion of the existing population is selected. In the crossover/mutation, a new generation is generated. Finally, it checks whether it meet the criteria. If it meets the criteria it gets terminate otherwise the iteration repeats.

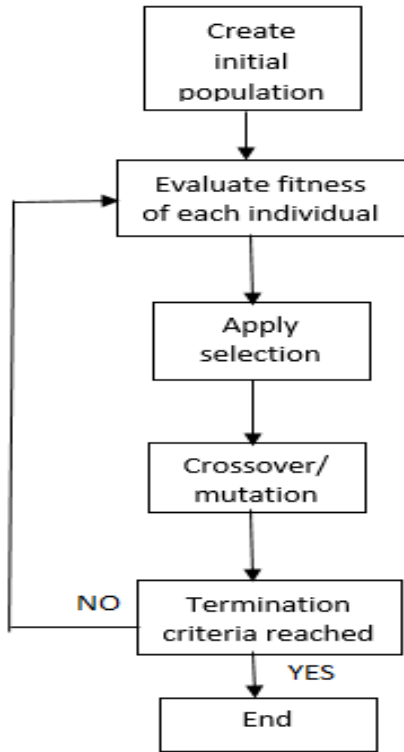

Figure. 6. Flowchart of genetic algorithm

6.1. Optimization of the PID and FOPID using genetic algorithm

The genetic algorithm can be implemented by using optimization toolbox. In FOPID tuning the parameter k_p, k_i, k_d, λ , and μ should be tuned to the proposed system.

The fitness function should be called as $@(x)$ fun name(x). The lower and upper limit of the cost function is shown in the table below.

Table 2. limit of FOPID parameter

FOPID PARAMETER	SET POINT (LOW)	SET POINT (HIGH)
K_p	0	2
K_i	0	2
Λ	0	1
K_d	0	2

μ	0	1

The parameter of genetic algorithm are chosen as in table

Table 3. criteria of genetic algorithm

Population	200
Initial population	10
Selection	Stochastic uniform
Mutation	Constraint dependent
Crossover	Constraint dependent

In PID tuning, k_p, k_i, k_d are the cost function.

The limit of PID controller is chosen as in table 4

Table 4. limit of PID controller

PID PARAMETERS	SET POINT (LOW)	SET POINT (HIGH)
K_p	0	2
K_i	0	2
K_d	0	2

Similarly by choosing criteria in optimization toolbox the parameter are tunes as shown in table 5.

Table 5. Tuned value of parameter of controller

	K_p	K_i	K_d	Λ	μ
PID	1.98	1.782	1.869	1	1
FOPID	1.904	1.7818	1.7061	0.1835	0.2217

The graphical representation is given by

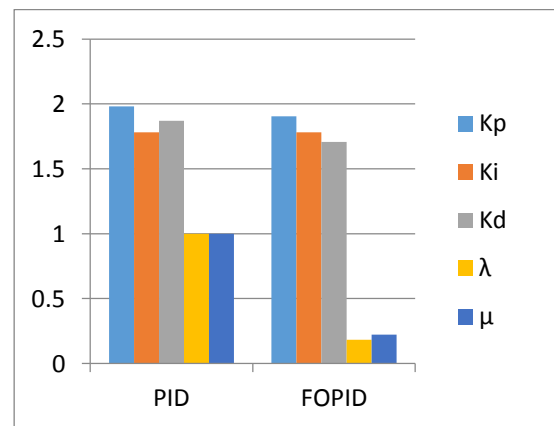

Figure. 7. Comparison plot

The graph generated while tuning the parameter of FOPID controller is shown in figure 8 and for PID

controller is shown in figure 9.

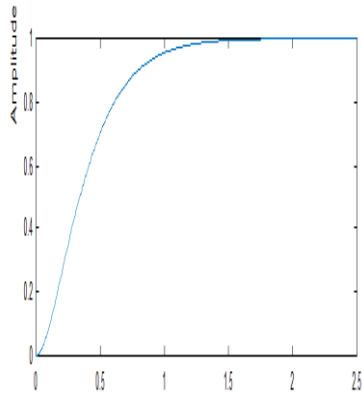

Figure.8. FOPID step response by genetic algorithm

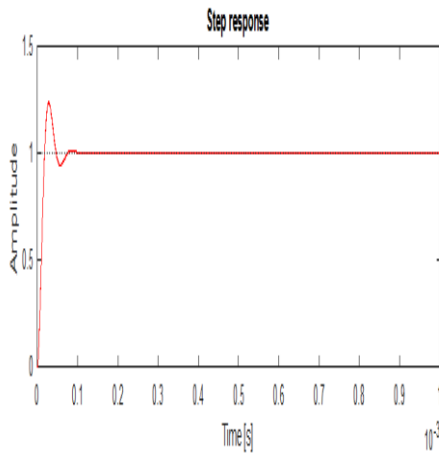

Figure. 9. PID step response by genetic algorithm

7. Simulation and Result

The simulation model of the speed control of BLDC motor is shown in figure 10. The PID controller is implemented by using PID block available in MATLAB. The transfer function of FOPID is generated by using FOMCON toolbox. The output speed response for PID controller is shown in figure 10.

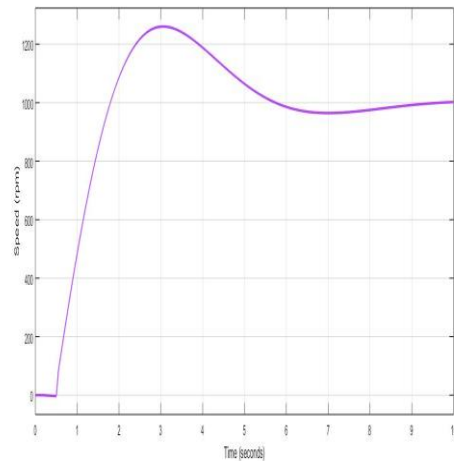

Figure. 10 speed response due to PID controller

An external disturbance is applied to the BLDC motor at 0.5 second. The PID controller controls the input voltage and the BLDC motor reaches the steady state at 8.5 second. Thus the settling time of the BLDC motor using PID controller is 8 second. The output speed response of the system due to FOPID controller is shown in figure 11.

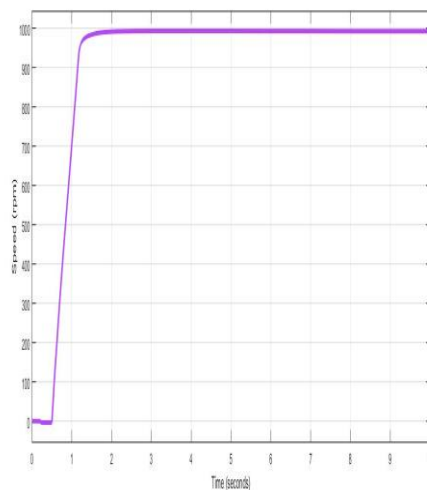

Figure.11. Speed response due to FOPID controller

An external disturbance is applied to the BLDC motor at 0.5 second. The FOPID controller controls the input voltage and the BLDC motor reaches the steady state at 1.3 second. Thus the settling time of the BLDC motor using FOPID controller is 0.8 second. Therefore the settling time of the speed due to the FOPID controller is 10.5 times faster than the PID controller. Comparison of PID and FOPID speed response is shown in figure 12.

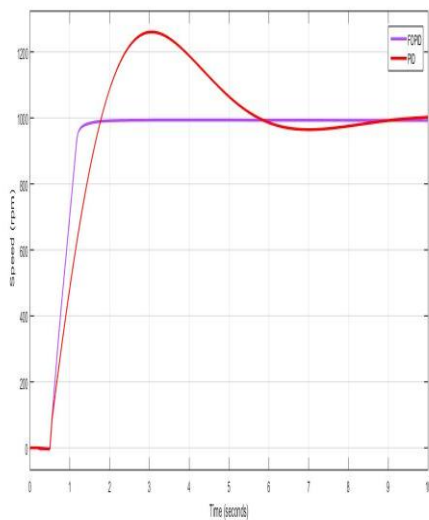

Figure. 12. Comparison of PID and FOPID speed response.

8. Conclusion

The FOPID controller enhances the dynamic response of the BLDC motor compared to the conventional PID controller. The settling time of the speed response is very fast when we use FOPID controller. So the performance of the FOPID based speed controller is better and efficient. Stability and robustness of the BLDC motor can be improved. So this proposed controller can be extended to other industrial control system.

References

- [1]Deep Mukherjee, Kshitij Rastogi, “A Performance Analysis Between IOPID and FOPID Controller on A Coupled Tank”, International Conference on Inventive Systems and Control, 2007.
- [2]Khubalkar.S.W, A. S. Chopade, A. S. Junghare and M. V. Aware, “Design and Tuning of Fractional Order PID Controller for Speed control of Permanent Magnet Brushless DC Motor”, IEEE First International Conference on Control, Measurement and Instrumentation (CMI),2017.
- [3]Wojciech Giernacki, “Near to Optimal Design of $PI^{\lambda}D^{\mu}$ Fractional-Order Speed Controller (FOPID) For Multirotor Motor Rotor Simplified Model”, 2016 International Conference on Unmanned Aircraft Systems ,2016.
- [4]WangLin, Zhong Chongquan, “Design of optimal fractional order PID controller using particle swarm optimization algorithm for DC motor system”, IEEE Advanced Information Technology, Electronic and Automation Control Conference (IAEAC), 2016.
- [5] Xiaotian Li, “Model-Based Design of Brushless DC Motor Control and Motion Control Modelling for RoboCup SSL Robots” Technology and Communication .
- [6]Ameer L. Saleh, Adel A. Obed, “Speed Control of Brushless DC Motor based on Fractional Order PID Controller”, International Journal of Computer Applications, Vol. 95, no.4,2017.
- [7]Narmada.K and M. Arounassalame, “Design and performance evaluation of Fractional ORDER controller for Brushless DC Motor”, International Journal on Electrical Engineering and Informatics – Vol. 6, no.3, September 2014.
- [8] Zhe Yan, Kai Li, Changqi Song, ling He, Yingyan Li, “Tuning and Application of Fractional Order PID Controllers”, International Conference on Measurement, Information and Control, 2013.
- [9]Sundaravadivu.K, B.Arun, K.Saravanan, “Design of Fractional Order PID Controller for Liquid Level Control of Spherical Tank”, IEEE International Conference on Control System, Computing and Engineering, 2011.
- [10] AlekseiTepIjakov, Eduard Petlenkov and JuriBelikov, “FOMCON: Fractional-Order Modeling and Control Toolbox for MATLAB”, MIXDES 2011, 18th International Conference "Mixed Design of Integrated Circuits and Systems", June 16-18, , Gliwice, Poland,2011.
- [11]Vishal Mehra, Smriti Srivastava, and PragyaVarshney, “Fractional-Order PID Controller Design for Speed Control of DC Motor”, Third International Conference on Emerging Trends in Engineering and Technology, 2011.
- [12]Olundayo john oguntoyinbo, “PID control of Brushless dc motor and ROBOT trajectory planning and simulink with MATLAB/SIMULINK”, Technology and communication, 2009,
- [13]Venu Kishore kadiyala, Ravi Kumar jatoth, sake pothalaiah, “Design and implementation of fractional order PID controller for Aerofin control system”, World Congress on Nature & Biologically Inspired Computing (NaBIC),2009.
- [14]Man.K.F, S. Tang, and S. Kwong, ‘Genetic Algorithms: Concepts and Applications’, IEEE Transactions On Industrial Electronics, Vol. 43, no.5, 1996.