

DESIGN AND IMPLEMENTATION OF FUZZY LOGIC AND SLIDING MODE MPPT CONTROLLER FOR SOLAR PV SYSTEM

First chinnamayan VENNILA

Alagappa Chettiar Government College of Engineering and Technology,
Karaikudi-630003, Sivagangai Dist,Tamilnadu,India,09629377320,c.vennila@yahoo.com

Second mariappan VIJAYARAJ

Government College of Engineering, Srirangam,
Trichy-620012,Tamilnadu,India,09442964798,mvijayaraj25567@gmail.com

Abstract: PV cell has single operating point where the value of current and voltage results in a maximum power output. PV cell is directly connected to the load, the output power can be drastically reduced due to the load mismatching. It represents maximum power is not delivered from PV source to load. So it is necessary to provide a MPPT technique to extract maximum power from PV cells. In order to improve the power extraction from solar PV the MPPT technique should be accurate and fast. In this paper performance analysis of standalone solar PV system having Non inverting Buck Boost converter with sliding mode control MPPT and fuzzy logic control MPPT controller is carried out. A detailed Mathematical modeling is done to confirm the stability of the system. Detailed simulation is done in MATLAB/Simulink for validating the model. The instantaneous power corresponding to various insolation for sliding mode controller and fuzzy logic controller for extracting maximum power are obtained and compared. These power output is compared with conventional P&O method. SMC shows a very good response for tracking MPP and FLC shows smooth tracking. Hardware implementation is done, which confirms the validity of the simulation results.

Key Words: Fuzzy Logic Control , Maximum Power Point Tracking (MPPT), Noninverting Buck-Boost Converter, Sliding Mode Control.

1. Introduction

Solar photovoltaic cell is a PN junction device through photovoltaic effect it converts light energy in to electrical energy. Energy of the photon in the light is more than the band gap energy then the

electron is emitted. Thus the flow of electrons constitutes current. The voltage and current associated with a PV cell exhibits a nonlinear characteristic in nature. PV module is created by combining PV cells by connecting them in series and parallel according to the required current and voltage ratings. The PV Module has an optimum operating point called Maximum Power Point (MPP) denotes the value of operating voltage and current of PV module to extract maximum power from it. This MPP varies on operating temperature and insolation on the module. Maximum power point tracking techniques along with any one of switch mode power converters can be used as MPP tracker. In this paper a noninverting buck-boost converter is used for this operation point.

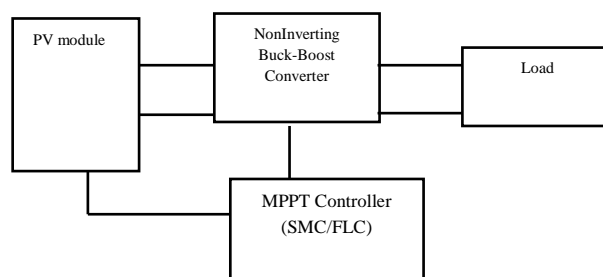

Fig. 1 Block Diagram

Perturb and Observe (P&O) MPPT technique is a well known technique used to extract maximum power [1]. A conventional P&O technique measures the dc-dc converter's output power to change the voltage at the input of the converter by varying the

duty cycle of the converter. Hill Climbing is another popular technique [1] based on a trial and error method. In this technique the voltage is increased up

MPPT technique is another technique in which a fixed percentage (71%-78%) [2] of open circuit voltage is used as module operating voltage to extract maximum power from solar PV. Fractional Short Circuit Current MPPT technique is another technique in which a fixed percentage (78%-92%) [2] of short circuit current is used as module operating current to extract maximum power from solar PV. Incremental conductance is also a well known MPPT technique where the operating condition of module is obtained by using dI/dV and $-I/V$ relationship [3]. So many other MPPT methods using Artificial Neural Network (ANN) technique, Fuzzy Logic Control (FLC), Particle Swarm Optimization (PSO), Ant Colony Optimization (ACO), Sliding Mode Control (SMC) and Genetic Algorithm (GA). In this work SMC based and FLC based MPPT techniques are used. Fig 1 shows the proposed system's block diagram.

2. Proposed System

2.1 PV cell Modelling

A solar PV cell can be modelled as a combination of a current source with a anti parallel diode. PV has its own series and parallel resistance. Series resistance is because of opposition to the flow of electrons from n to p layer and parallel resistance is because of leakage current. Fig 2 shows the equivalent circuit of solar cell [4].

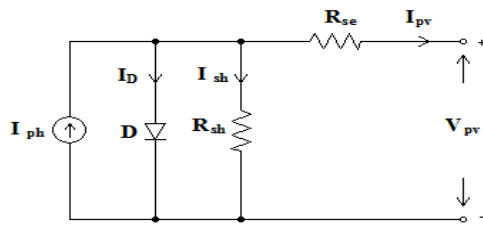

Fig. 2. Single Diode Model of Solar Cell

With respect to the Ortiz photovoltaic model, analytical equations are used to relate the PV current with PV voltage for a given temperature and irradiance on single PV cell. The equations are as follows,

$$I(v) = \frac{I_{sc}}{1 - \exp\left(\frac{V_{pv} - 1}{bV_{oc}}\right)} \left[1 - \exp\left(\frac{V_{pv} - 1}{b}\right)\right] \quad (1)$$

to the value the PV Module outputs maximum power. Fractional Open Circuit Voltage

$$P(v) = V_{pv} I(v) \quad (2)$$

$$V_{oc} = \frac{I_r}{I_{std}} T_{cvoc}(T_{pv} - T_{std}) + V_{max} - (V_{max} - V_{min}) \exp\left(\frac{I_r}{I_{std}} \ln\left(\frac{V_{max} - V_{oc}}{V_{max} - V_{min}}\right)\right) \quad (3)$$

$$I_{sc} = \frac{I_r}{I_{std}} (I_{sc} + T_{cisc}(T_{pv} - T_{std})) \quad (4)$$

$$b_{n+1} = \frac{V_{op} - V_{oc}}{V_{oc} \ln\left[1 - \frac{I_{op}}{I_{sc}} (1 - \exp\left(\frac{1}{b_n}\right))\right]} \quad (5)$$

$$\frac{\partial P(V)}{\partial V} = \frac{\left(I_{sc} - I_{sc} \exp\left(\frac{V_{pv} - 1}{bV_{oc}}\right) - V_{pv}\right)}{1 - \exp\left(\frac{1}{b}\right)} - V * \frac{-I_{sc} \exp\left(\frac{V_{pv} - 1}{bV_{oc}}\right) \left(\frac{-1}{b}\right)}{bV_{oc} - bV_{oc} \exp\left(\frac{1}{b}\right)} \quad (6)$$

at MPPT $dP/dV=0$, by solving eqn (6) V_{op} is obtained [5].

$$V_{op} = C V_{oc} \quad (7)$$

$$C = Re\left(b \left(\text{lambertw}\left(-0.36787944 \exp\left(\frac{1}{b}\right)\right) + 1\right)\right) \quad (8)$$

Six parameters needed for the model are taken from the manufactures data sheet and characteristic constant b [11]. V_{max} is the V_{oc} at standard temperature with irradiance more than 1200w/m^2 . V_{min} is the V_{oc} at standard temperature with irradiance less than 1200w/m^2 [5]. Through MATLAB m-file program using Fixed Point Algorithm the value of Characteristic constant b was found 0.0839 with error tolerance 10^{-7} .

Table 1
Electrical specifications of 85W solar panel in simulation

Description	Rating
Short-circuit current I_{sc}	5.45 A
Open-circuit voltage V_{oc}	22.2 V
Current at P_{max}	4.95 A
Voltage at P_{max}	17.2 V
Temp co-efficient of $V_{oc}(T_{cvoc})$	-64.5mV/°C
Temp Co-efficient of $I_{sc}(T_{cisc})$	1.4mA/°C

Table 1 shows the electrical specifications of the panel to be modeled. The I-V and P-V curves for a solar cell under STC are also given in the Fig 3a and 3b. Curves reveals that the cell operates as a constant current source at low values of operating voltages

and a constant voltage source at low values of operating current.

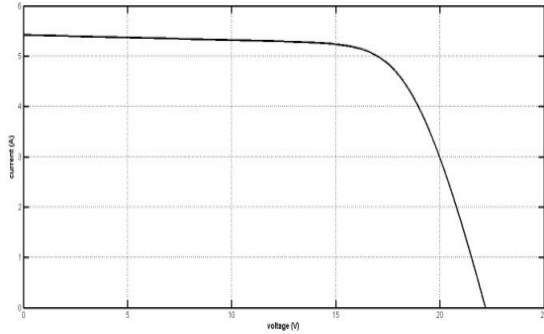

Fig. 3 a) I-V Characteristics of a PV module for 1000W/m²

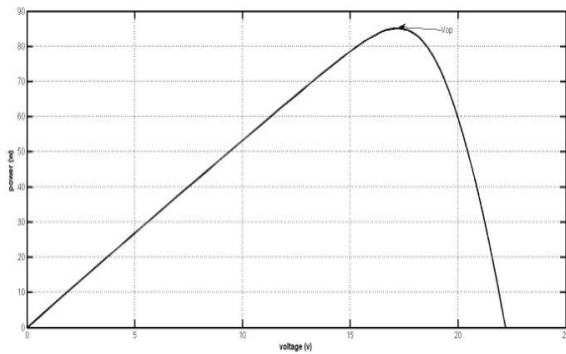

Fig. b) P-V Characteristics of a PV module for 1000W/m²

2.2. Non Inverting Buck Boost Converter

DC-DC converter is used as switching mode regulator to maintain regulated dc voltage at output. The regulated voltage at output is achieved by fixed frequency of 20 kHz for PWM and the switching device is MOSFET. In order to reduce the current stress and improve the efficiency buck mode is preferred in this work [6]. Fig 4 shows the schematic diagram of Non Inverting Buck –Boost converter with 12V battery as load.

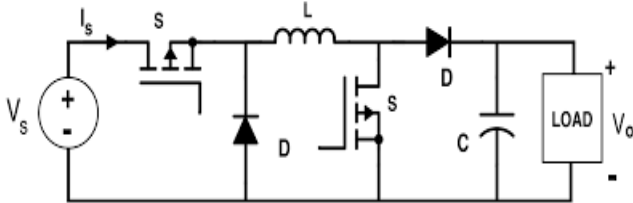

Fig. 4 Schematic Diagram of Non Inverting Buck-Boost Converter

With reference to the circuit arrangement with switch S_1 active and with switch S_2 off the converter works in the buck mode. In this case the diode D_1 acts as the freewheeling diode. The circuit obeys the

steady state input output voltage relationship as given by $V_{out} = V_{in} * k$. Where k is the duty cycle. Input voltage expected between 10V and 20V. As long as the input voltage is more than 12 volts the TSBB will work as a buck converter. With an input voltage of 20 volts the duty cycle to deliver an output voltage will be $k = 0.6$. With an input voltage of 12 volts the value of k will be 1. Therefore the value of k will lie anywhere between 0.6 and 1 depending upon the source voltage. Circuit components are designed as follows with 2% of current ripple and 3% of the voltage ripple limitations,

$$D_{buck} = V_o/V_{in} \quad (9)$$

$$I_o = P_o/V_o \quad (10)$$

$$I_L = I_o/(1-D) \quad (11)$$

$$L_{cr} = V_{in} * D/f * \Delta I_L \quad (12)$$

$$C_{cr} = I_o * D/f * \Delta V_o \quad (13)$$

Table 2 represents the values of circuit components of Non Inverting Buck Boost converter in simulation.

Table 2

Specifications of converter components used in simulation

Component	Description
MOSFET	IRF540
Capacitor	100 μ F
Inductor	500mH
Diode	MUR604
Switching frequency	20kHz

2.3. Sliding Mode Controller

Sliding mode controller can be designed by selecting the desired surface [7,8]. Maximum power can be extracted from the PV module at the given temperature and irradiance conditions. Maximum power can be related to an optimal voltage V_{op} with help of fill factor. Multiplying the instant open circuit voltage with fill factor V_{op} is obtained. Fill factor is the ratio of V_{max} to V_{oc} . Since the output voltage is known the maximum power can be extracted from the PV system. Surface can be chosen so as to force the system to reach that voltage in a finite time and stay there for infinite time. With that in mind, the following sliding manifold is chosen,

$$\sigma = V - V_{op} \quad (14)$$

V_{pv} is the voltage output of the PV panel V_{op} is the optimal voltage. This sliding manifold forces all the trajectories of the system to reach the optimal voltage and to keep it in the optimal voltage for all

future time. The optimal voltage is dynamic in solar PV system it changes with changes in irradiance and temperature.. Duty cycle of the converter is controlled by this sliding manifold. Switching device operating states are,

$$\begin{cases} On & V - V_{op} > 0 \\ Off & V - V_{op} < 0 \end{cases} \quad (15)$$

The controller output as follows

$$u = \begin{cases} 1 & V - V_{op} > 0 \\ 0 & V - V_{op} < 0 \end{cases} \quad (16)$$

A control law for controller is as follows

$$u = \frac{1}{2} + \frac{1}{2} \cdot \text{sign}(V - V_{op}) \quad (17)$$

For a 10W solar panel's V_{op} given in datasheet is 16.8V, where as V_{op} estimated is 17.0991V. Error is 0.2991V. Same way I_{op} is 0.59A and the estimated I_{op} is 0.5790A, error is 0.011A. Hence the power supplied to the battery rises to 0.0116W. Then the power to the battery is incremented by 26% with converter.

2.4. Fuzzy Logic Controller

The expected variation in the V_{oc} is in the range [0 24] and V is in the range [9 11]. Since the converter duty cycle is lies between 0.6 to 1 the range of ΔD is taken as [-5 5]. In this work the inputs to a MPPT fuzzy logic controller are error and change in error.

$$\text{error } E(n) = V_{op} - V_{act} \quad (18)$$

$$\text{change in error } \Delta E(n) = E(n) - E(n-1) \quad (19)$$

$E(n)$ and $E(n-1)$ are calculated and converted to the linguistic variables, the fuzzy logic controller output, which is a change in duty ratio ΔD of the power converter is obtained. During fuzzification, numerical input variables are converted into linguistic variables based on a 7 similar triangular membership functions. The seven fuzzy levels used are NB (negative big), NS (negative small), ZE (zero), PS (positive small), and PB (positive big) [20]. The values beyond the range are taken as PB and NB. The narrow range selection of error and change in error is because of the enhancement in system steady state performance. According to the Mamdani Inference Rule base table is designed and shown in Table 3. The Max-Min method is used to

get membership value from membership functions. During defuzzification Centroid method is used to get proper value of ΔD which is to be added with current value of D .

Table 3
Fuzzy rule base table

error	Δ error	NB	NM	NS	ZE	PS	PM	PB
NB	NB	NB	NB	NB	NM	NM	NS	ZE
NM	NB	NB	NM	NM	NS	ZE	PS	PM
NS	NB	NM	NS	ZE	PS	PM	PM	PB
ZE	NM	NS	ZE	PS	PM	PM	PB	PB
PS	NM	NS	ZE	PS	PM	PM	PB	PB
PM	NS	ZE	PS	PM	PM	PB	PB	PB
PB	ZE	PS	PM	PB	PB	PB	PB	PB

2.5. P&O MPPT

PT technique output voltage only sensed. The power output of PV system is checked by changing the voltage of the PV. When operating voltage is increased, power is also an increase further ΔD is increased otherwise ΔD is decreased. In same way, when voltage is decreased if power increases the ΔD is decreased. These steps are repeated until PV module approaches V_{op} . The flow chart is shown in Fig 10.

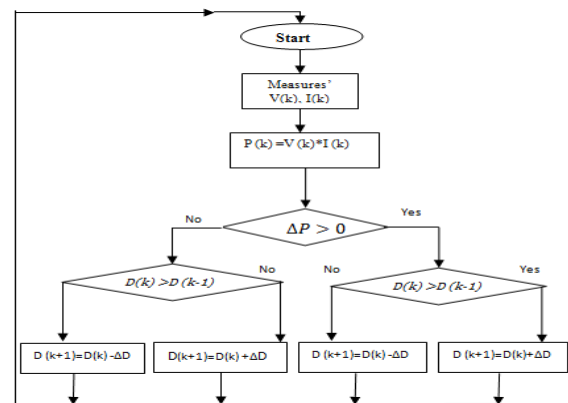

Fig. 5. Flow Chart of P and O method

3. Simulation

The simulation is done for both SMC and FLC and power outputs are compared. These power outputs are also compared with P & O method. All simulations are done using MATLAB/SIMULINK software. The PV

module block used in this paper is not temperature dependent. The PV panel specifications are listed in Table I. The input to the PV module is insolation and the current. The outputs of the PV module are voltage and power where the voltage output terminal is connected to the 12 V battery Load through Noninverting buck-boost converter.

3.1. Simulation of Sliding Mode Controller

Fig 6a shows the simulation diagram of sliding mode controller and the Fig 6b shows simulated waveforms.

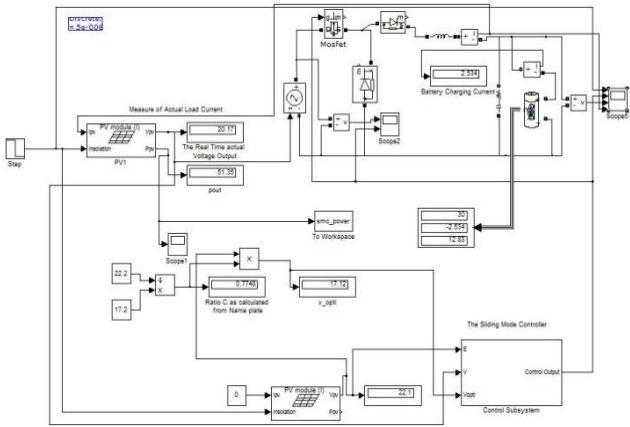

Fig. 6a Simulation Diagram of Sliding mode Controller

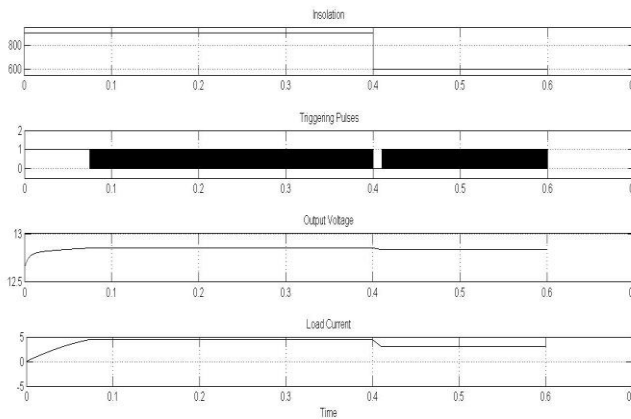

Fig. 6b Simulated waveforms of SMC

3.2. Simulation of Fuzzy Logic Controller

Fig 7a shows the simulation diagram of fuzzy logic controller and the Fig 7b shows simulated waveforms.

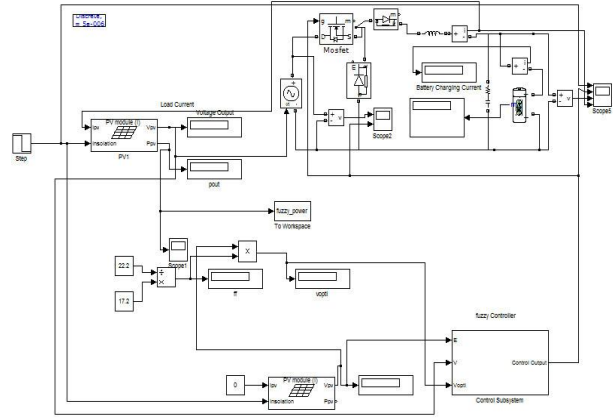

Fig. 7a Simulation Diagram of Fuzzy Logic Controller

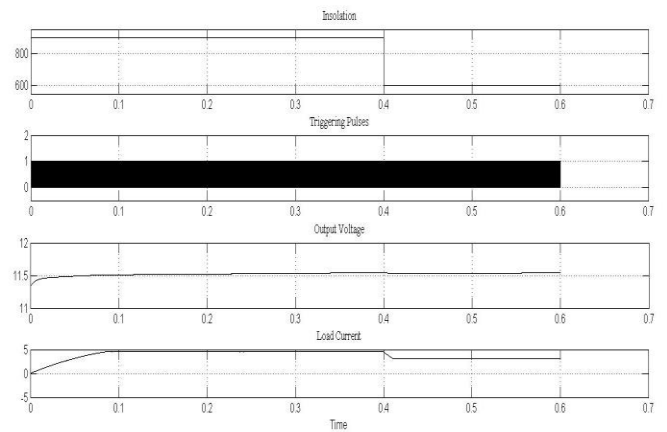

Fig. 7b Simulated waveforms of FLC

3.3. Simulation P&O method

Fig 8 shows the simulation diagram of fuzzy logic controller and the

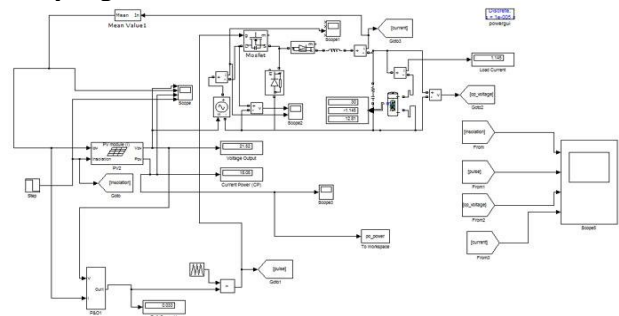

Fig. 8 Simulation Diagram of P and O Method

3.4. Comparison of SMC and FLC

Figure 9 and 10 shows simulated waveforms for comparison. The output voltage is sensed and given to the controller. The output of the sliding mode controller either turns on or turns off the switch. Where as in fuzzy logic controller duty cycle of converter is either increased or decreased. Both voltage and current are sensed in P & O method and given to P&O block. The output of

the P & O block controls duty cycle of converter. The simulation is done for 0.6 second which the step change is given at 0.4 second, at 0.4 second the insolation is changed from 900 to 600 w/m² and the power output for SMC, FLC, P&O techniques are compared.

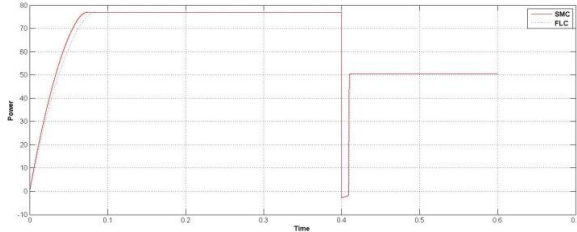

Fig 9. Power output comparison of SMC (red) and FLC (blue)

When comparing SMC with FLC, the SMC power output reaches the maximum point quicker than FLC. After changing the insolation in 0.4 second FLC power output has faster response than SMC. Both these method has faster response than P&O method after insolation change when comparing. However P&O power reaches the maximum power greater than FLC power. It is found that SMC for voltage based technique is somewhat smoother.

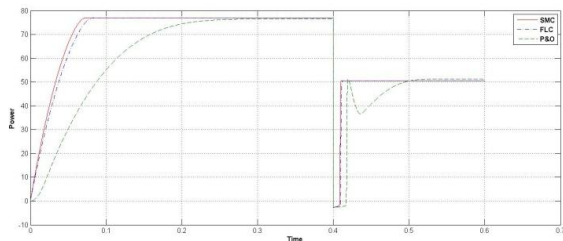

Fig 10. Pout comparison of SMC and FLC with P&O (green)

The power output of SMC and FLC are compared and shown in fig 10. It is found that both power output has slight differences. The power output of SMC can able to track peak power faster than FLC and also the peak power of SMC is slightly greater than FLC. Both power outputs of SMC and FLC are compared with P&O method.

4. HARDWARE IMPLEMENTATION

The hardware implementation is done for voltage based SMC and voltage based FLC. Both outputs are compared by varying insolation.

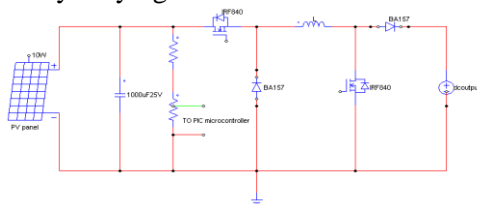

Fig 11. Circuit Diagram of Proposed System

In this work a 10 watts panel is used and the specifications of Solar Panel and circuit components are shown in Table 4 and 5.

Table 4
Electrical specifications of 10W solar panel

Description	Rating
Short-circuit current I_{sc}	0.65 A
Open-circuit voltage V_{oc}	21.0 V
Current at P_{max}	0.59 A
Voltage at P_{max}	16.8 V

The hardware is done for buck -boost converter also and switch parallel to the source is left open to operate in buck mode only. Input to this buck converter is 10W PV panel. Across this PV panel 1000µF 25V capacitor is used reduce input ripples and 10 k pot is used for scaling the voltage across PV panel and is given to the PIC microcontroller. The PIC microcontroller can be operated in the voltage range of 0 to +5 V only. So the pot is tuned to 5 V when the panel voltage is maximum.

Table 5
Specifications of hardware converter components

Component	Description
MOSFET	IRF840
Capacitor	1000µF
Inductor	500mH
Diode	BA157
Switching frequency	20kHz

The experimental setup for both sliding mode control and fuzzy logic control are same. The only difference is program. Fig 12 shows the circuit diagram for control unit. Here PIC 16F877A is used. Input from PV panel is given to RA0 pin of PIC microcontroller through 10 K pot. RA0 and RA1 are pin used for reading analog signals .Output of the PIC microcontroller is given to opto-coupler MCT2E which in turn drives the IRF 840 MOSFET used in converter.

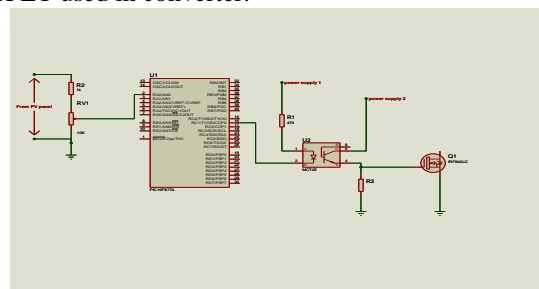

Fig 12. Circuit Diagram of Control Circuit with PIC 16F877A

Initially the switch will be opened and the open circuit voltage is sensed through RA0 pin and the value at that instant is stored in V_{oc} . Then the switch is closed and value at that instant is stored in V_{op} . If V_{op} is less than C of V_{oc} means the switch is opened or else it is closed. Like this the pulses are generated by PIC 16F877A and is given to buck converter switch. Both the controllers are compared by changing the insolation which is shown in Fig 13. The insolation to the solar panel is given with help 200 watts bulb. The brightness of bulb is varied with help of 0-230 volt variac. An ammeter is used in series with the variac. The readings are taken by varying variac from 0.25 to 0.75 amps with 0.05 intervals.

The DC input voltage, DC current and DC output voltage are noted and tabulated in Tables 6 and 7. The values of voltage and current at particular instant are multiplied to get power and this power is plotted against insolation with the help of MATLAB software. The brightness of bulb which can also be called as insolation depends upon the current in the variac. So the insolation is directly proportional to current in variac. This current multiplied by 100 to get the approximate insolation.



Fig 13a. Pulses generated by PIC16F877A for SMC

From the graph of Fig 15, it is found that sliding mode controller can able to track more power than fuzzy logic controller in the insolation range from 500 to 800. In higher insolation fuzzy logic controller can able to track more power than sliding mode control.

There are slight differences only but it is found that the response of sliding mode controller is faster than fuzzy logic controller. Pulses are instantly changed when the insolation is changed in sliding mode controller where as in fuzzy logic controller the pulse width is increased or decreased.

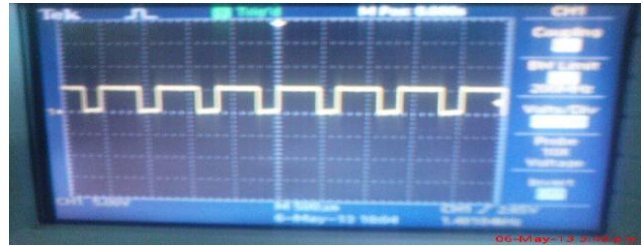

Fig 13b. Pulses generated by PIC16F877A for FLC

Table 6
Power output for various insolation using FLC

S.No	AC input from variac	DC input (voltage)	DC current (milli amps)	Output DC voltage (volts)	Input power (milli watts)
1	0.25	1.1	0.8	0.69	0.88
2	0.3	1.5	1.3	1.234	1.95
3	0.35	2.8	2.7	2.52	7.56
4	0.4	4.3	4.2	3.96	18.06
5	0.45	6.5	6.5	6	42.25
6	0.5	9	9.3	8.53	83.7
7	0.55	11.5	11.8	10.84	135.7
8	0.6	14.2	14.7	13.38	208.74
9	0.65	16.6	17.2	15.78	285.52
10	0.7	17.5	18.2	16.7	318.5
11	0.75	18.1	18.8	17.25	340.28



Fig 14. Hardware setup for Comparison of SMC and FLC

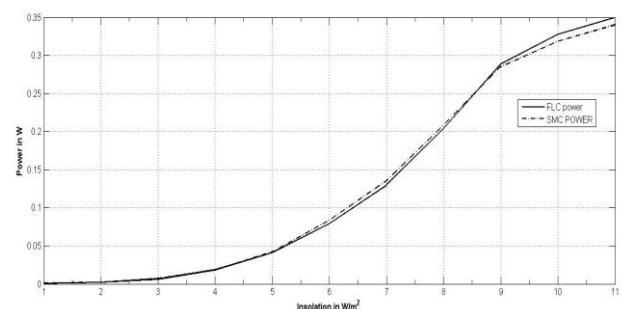

Fig 15. Comparison of power output of SMC and FLC

Table 7
Power output for various insolation using SMC

S.No	AC input from variac	DC input voltage (volts)	DC current (milli amps)	Output dc voltage (volts)	Input power (milli watts)
1	0.25	1	0.8	0.8	0.64
2	0.3	1.6	1.4	1.4	1.96
3	0.35	2.7	2.5	2.5	6.25
4	0.4	4.4	4.3	4	18.49
5	0.45	6.4	6.4	5.9	40.96
6	0.5	8.8	8.9	8.27	79.21
7	0.55	11.1	11.4	10.82	129.96
8	0.6	13.8	14.3	13.35	204.49
9	0.65	16.4	17	15.71	289
10	0.7	17.4	18.1	16.6	327.61
11	0.75	18	18.7	17.2	349.69

5 .CONCLUSION

The power output of SMC and FLC are compared and it is found that both power output has slight differences. The power output of SMC can able to track peak power faster than FLC and also the peak power of SMC is slightly greater than FLC. Both power outputs of SMC and FLC are compared with P&O method. It is found that both SMC and FLC has good response after step change at 0.4sec than P&O method and also tracking of peak power is faster in SMC and FLC than P&O. SMC provides a very good tracking speed for fast change, slow variation and constant solar irradiation on panel power. FLC technique presents a much smoother tracking with small fluctuations.

REFERENCES

1. Trishan Efram, Student Member, IEEE, and Patrick L. Chapman, Senior Member, IEEE” Comparison of Photovoltaic Array Maximum PowerPoint Tracking Techniques”,IEEE Transaction ,Energy Conversions, Volume 22,no.2,pp 439-449, June2007
2. Ariya Sanwongwanich,F.Blaabjerg, ”A Sensorless Power Reverse Control Strategy for Two-Stage Grid Connected PV Systems”, IEEE Transactions on Power Electronics, October 2017,pp(99),1-11
3. Safari, A. & Mekhilef, S.,” Simulation and hardware implementation of incremental conductance MPPT with direct control method using Cuk converter”, IEEE Transactions on Industrial Electronics, 58, 1154–1161,2011
4. Mohamed Salem Abdul Kareem, Manimaran Saravanan, “A new method for accurate estimation of PV module parameters and extraction of maximum power point under varying environmental conditions”, Turkish journal of electrical engineering and computer sciences(2016),24:2028-2041 doi:10.3906/elk-1312-268
5. Ortiz-Rivera, Eduardo I; Peng, F.Z., "Analytical Model For A Photovoltaic Module Using The Electrical Characteristics Provided By The Manufacturer Data Sheet”, Power Electronics Conference, 2005.Pesc’05. IEEE 36th, Vol. Pp 2087-2091, 11-14 Sept.2005.
6. Yaosuo Li, Kai Liu, Hui Wang, Min Gu. “Performance Evaluation of Controller Design Based on Accurate Model of Non-Inverting Buck Boost Converter Fed by Photovoltaic Module”. American Scientific Research Journal for Engineering, Technology and Sciences(ASRJETETS),2017,30(1).
7. Emil A. Jimenez Brea, Eduardo I. Ortiz-Rivera, Andres Salazar- Llinas, Jesus Gonzalez-Llorente, “Simple Photovoltaic Solar Cell Dynamic Sliding Mode Controlled Maximum Power Point Tracker for Battery Charging Applications”, 978-1-4244-4783- 1/10 ©2010 IEEE.
8. Vennila. C. ,Vijayaraj, M.,” A Novel MPPT Scheme for an Unequally Irradiated Solar Photovoltaic Panels Feeding a Common Load Using Sliding Mode Controller”, Current Signal Transduction Therapy, Volume 13, Number 1, August 2018, pp. 11-18(8).
9. Rajeshree Patil1 , Harsha Anantwar “Comparative Analysis of Fuzzy Based MPPT for Boost and SEPIC Converter Topologies for PV Application” IOSR Journal of Electrical and Electronics Engineering (IOSR-JEEE) e-ISSN: 2278-1676,p-ISSN: 2320-3331, Volume 12, Issue 3 Ver. IV (May – June 2017), PP 56-61
10. Riza,B. Sheldon,T. (1997). “Fuzzy Systems Design Principles Building Fuzzy IF-THEN Rule Bases”, IEEE PRESS.
11. Addelhakim Bekaid, Jean Paul Gaubert, Ahmed Gherbi “Design and implementation of a high-performance technique for tracking PV peak power”, IET Renewable Power Generation (Volume: 11, Issue: 1, 1 11 2017).