

# Performance analysis of High Gain Interleaved Boost Converter with voltage multiplier For Drip Irrigation

\*<sup>1</sup>K.V.Thilagar, <sup>2</sup>K.Mala and <sup>3</sup>P. Marish Kumar

\*<sup>1</sup>Assistant Professor, Easwari Engineering college, Chennai, India. kvthilagar@gmail.com

<sup>2</sup>Professor, Easwari Engineering college, Chennai, India

<sup>3</sup>Assistant Professor, Easwari Engineering college, Chennai, India

**Abstract:** *In this paper, fuel cell powered water pump using two phase interleaved boost converter with voltage multiplier is analyzed. Nowadays fuel cell becomes more passion for various standalone applications. DC-DC converters are mandatory between a fuel cell and load. To reduce power loss interleaved boost converter is proposed with the combination of the voltage multiplier. To enhance the performance of IBC with voltage multiplier Anti wind up PI controller is proposed in this paper. The entire system is analyzed using Matlab. To validate the performance of the proposed system it is compared with the PI controller based system.*

**Keywords:** *IBC with a voltage multiplier, fuel cell, PI, AWPI, SPIM.*

## 1. Introduction:

Fuel cells are predictable to become an important part in future distributed generation (DG) applications [1]. Fuel cells are static energy conversion devices that convert the chemical energy in hydrogen rich fuel to electricity in an efficient, quiet, and clean way. Fuel cells are chosen for the benefits of high efficiency, zero or low emission (of pollutant gases) [2], and flexible modular structure, compared with conventional power generation systems. Fuel cell DGs (FC DGs) can either be grid connected or stand-alone for various applications such as vehicles, water pumping, lighting etc. In this paper fuel cell is analyzed with the standalone water pumping application. An output voltage of fuel cell varies with the change in temperature and flow rate; hence a DC-DC boost converter is necessary to regulate the voltage.

Interleaved buck and boost converters have been studied in recent years to improve power converter performance in terms of efficiency, size, conducted electromagnetic emission, transient response and reliability. In an

IBC Coupled inductors provide the additional benefit of reduced winding loss and core loss with better input and inductor current ripple [3]–[5]. Various researchers analyzed the improvements in the performance of interleaved boost converters (IBCs) with the modification in core such as an E-E core coupled inductor [3]–[7], and E-I core-based coupled inductors [8] and [9]. In this paper two phase interleaved boost converter with voltage multiplier is proposed for analysis [10] [11]. Various controllers were analyzed for interleaved boost converters by many researchers. In a conventional PI controller, an integral windup phenomenon is a major drawback. Hence in this paper anti windup PI controller is proposed to control IBC.

This paper proposes anti windup PI controller for interleaved boost converter with voltage multiplier for fuel cell powered water pump.

## 2. Proposed System:

The proposed system consists of a fuel cell, two phase interleaved boost converter with voltage multiplier, single phase inverter, single phase induction motor (SPIM), PWM generator and AWPI controller for IBC control. Block diagram of a proposed system is shown in figure 1.

Fuel cell output voltage is boosted with the help of two phase IBC with voltage multiplier. AWPI controller controls the duty cycle of switching devices in an IBC. The output of the AWPI controller is compared with the high frequency triangular signals to produce pulses. As the FC delivers DC power, it must be inverted to meet the load. Typical simple 4 MOSFETs based single phase inverter is connected to convert available DC into AC required to run SPIM.

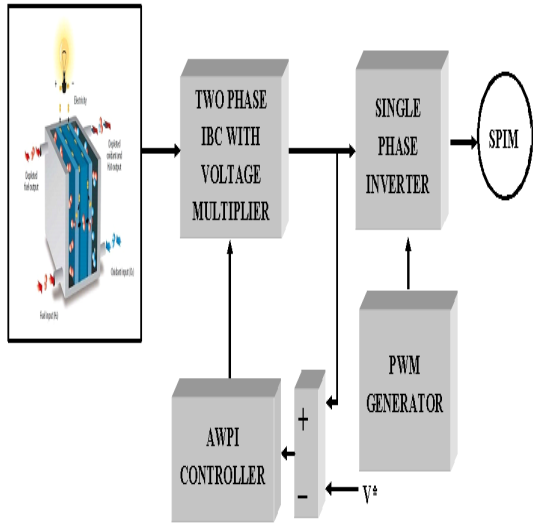

Figure 1 Block diagram of the proposed system

### 3. Fuel cell:

A single fuel cell generates small voltages, in the range of 1 V, and must be connected in series to raise and attain required voltage to meet an electric load [12]. The efficiency of the FC depends on fuel processing, water management, temperature control, ohmic loss, activation loss [13], and concentration loss. To analyze the closed loop control of an IBC, fuel cell output voltage is varied.

### 4. Proposed IBC with voltage multiplier:

Two phase IBC with voltage multiplier cell consists of two switches ( $M_a$  &  $M_b$ ), two diodes ( $D_a$  &  $D_b$ ), two inductors ( $L_a$  &  $L_b$ ) same as to conventional IBC additionally it has one more capacitor ( $C_a$ ) for voltage lifting other than output capacitor ( $C_b$ ). The connection of diodes and capacitors are changed from typical connection as shown in figure 2.

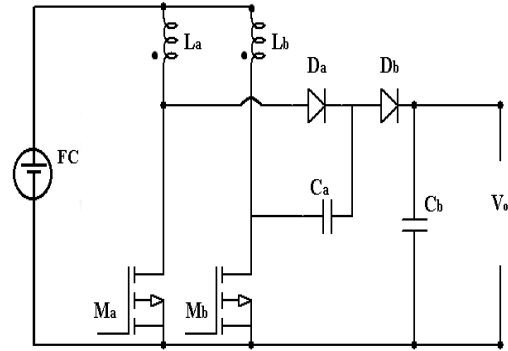

Figure 2 Circuit of IBC with voltage multiplier

When switch  $M_a$  is off during this period, the voltage across diode  $D_a$  is zero because diode conducts the current of boost inductor  $L_a$ . when switch  $M_b$  is off during this period, the voltage across diode  $D_a$  is  $V_o$  since diode  $D_b$  conducts the current of boost inductor  $L_b$  and switch  $M_a$  is on.

When both switches are on the voltage across the diode  $D_a$  is equal to the voltage across  $C_a$  ( $V_x$ ). Since the off time of both switches is identical, the voltage across a blocking capacitor is as follows,

$$V_x = V_o/2$$

The equations that are necessary to design the elements of converter are as follows.

The gain of the converter is given by [14]:

$$M = \frac{V_o}{V_{in}} = \frac{2}{1-D} \quad (1)$$

Where  $V_o$  and  $V_{in}$  are the input and output voltages and  $D$  is the duty ratio. The inductors and capacitors are designed using the formulas:

$$L = \frac{V_{in}D}{\Delta I_L f_s} \quad (2)$$

Where  $f_s$  is the switching frequency and  $\Delta I_L$  is the Inductor current ripple content.

$$C = \frac{DV_o T}{R\Delta V_o} \quad (3)$$

Where  $T$  is the time period,  $R$  is the load resistance and  $\Delta V_o$  is the output voltage ripple.

From the above design equation, it is noted that high gain will be achieved when  $0.5 \leq D \leq 1$ . In this analysis, PI/AWPI decides the  $D$  to control voltage.

#### 4.1 PI controller for IBC:

A proportional integral controller is massively utilized in many industrial control systems for its simple and easy implementation. In this paper, a PI controller is proposed to control the duty cycle of IBC to regulate the output voltage. Voltage error is given as input to the PI controller to produce the duty cycle. An equation of PI controller for IBC is as follows

$$d = K_p e(s) + \frac{K_i}{s} e(s) \quad (4)$$

$$e = V_{dc}^* - V_{dc}$$

where  $d$  is the duty cycle,  $K_p$  is proportional gain,  $K_i$  is the integral gain,  $e$  is the voltage error.

#### 4.2. AWPI controller for IBC

An integral action in a PI controller extensively causes windup or rollover problem [15], [16]. This issue happens in two cases (i) while the input error remains nonzero for a long time (ii) while the input error to the controller is significant. Nonzero errors happen when speed reaches and/or settles above or below the reference speed. Variation in the output of fuel cell makes the converter output voltage variation. Hence it is required to conquer the windup phenomenon with the help of AWPI method. Figure 3 shows the anti windup PI controller for voltage control of IBC.

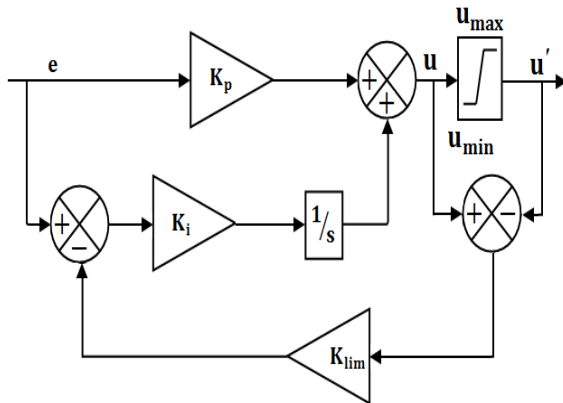

Figure 3 Block Diagram of Anti windup PI Controller.

Output 'd' can be expressed as

$$d(t) = \left( X_0 - \frac{e}{K_{lim}} - d_{max} + K_p \times e \right) \exp^{-K_i K_{lim} t} + \left( \frac{e}{K_{lim}} + d_{max} \right) \quad (5)$$

Where  $X_0$  is the initial value of state 'x', If steady state value of 'd' is  $d_{ss}$ , then

$$d_{ss} = d_{max} + \frac{e}{K_{lim}} \quad (6)$$

It can be noted from the steady state and dynamic relationships that, while the error input 'e' is less than zero ie, negative, the  $K_{lim}$  value has to be high therefore the  $d_{ss} \approx d$  as a result that controller will shift out from the saturation quickly.

#### 5. Simulation results and analysis

A fuel cell of 24V, 1kw is applied to run 1HP, 230V, and 50Hz single phase induction motor. To study the performance of PI/AWPI controller as IBC voltage controller, fuel cell output is considered in both cases such as constant and variable. Consider a case that fuel cell output voltage is varied from 20V to 24V at the time of 2 sec. To attain 230V AC in an inverter, IBC output is set to reference voltage of 325V. Performance of PI, AWPI based systems is presented in the aspects of IBC output voltage, Inverter voltage and motor speed in figures 4 and 5 respectively.

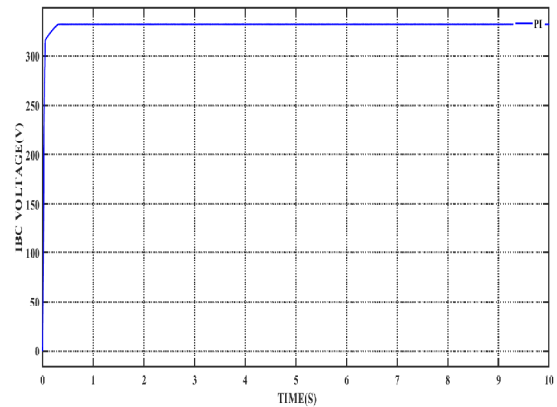

Figure 4 (a) IBC output voltage using PI

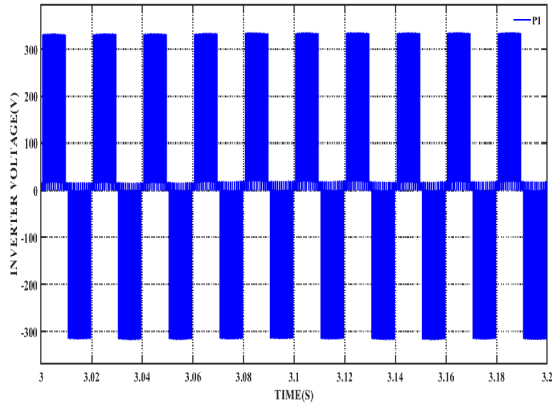

Figure 4 (b) Inverter voltage

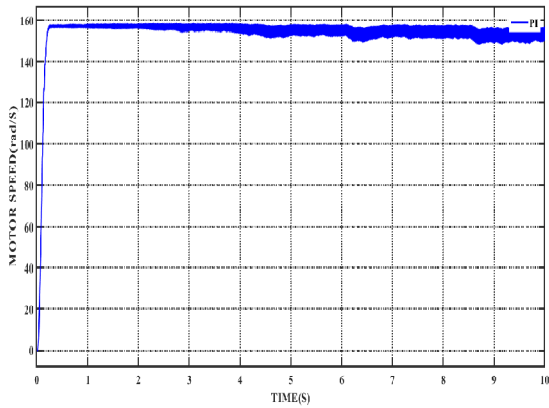

Figure 4 (c) Motor speed

Figure 4 Performance of PI based proposed system under variable input voltage

From figure 4(a) it is noted that voltage settles in 333V while the reference voltage is 325V, which states the steady state error in converter voltage. It impacts in an inverter voltage too. Figure 4 (c) shows that the oscillation in speed after settling of voltage is noticeable and has to be reduced.

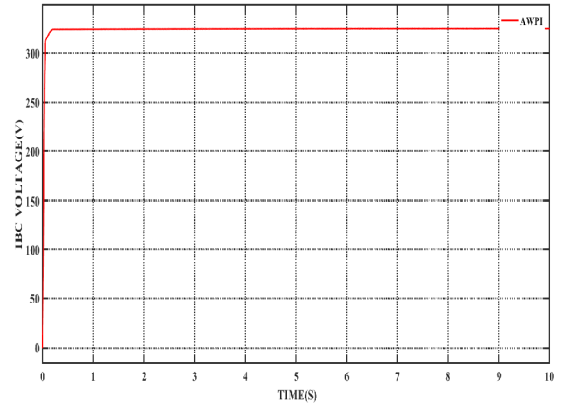

Figure 5 (a) IBC output voltage using AWPI

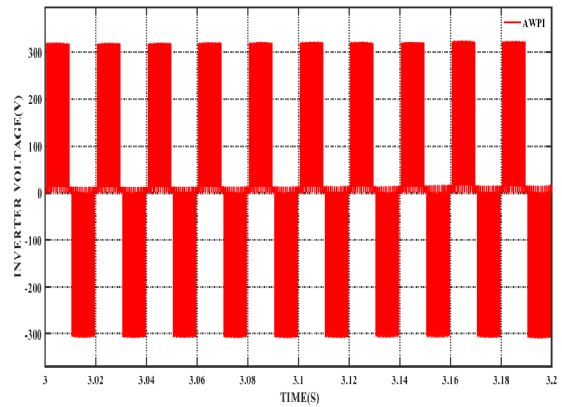

Figure 5 (b) Inverter voltage

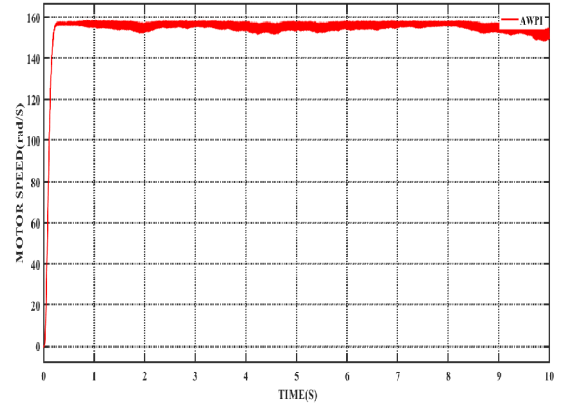

Figure 5 (c) Motor speed

Figure 5 Performance of AWPI based proposed system under variable input voltage

From figure 5 it is observed that converter voltage settles in 324.5V which is almost equal to the reference voltage. It states that the steady state error is reduced.

Comparative performance of PI and AWPI controller based system is shown in figure 6.

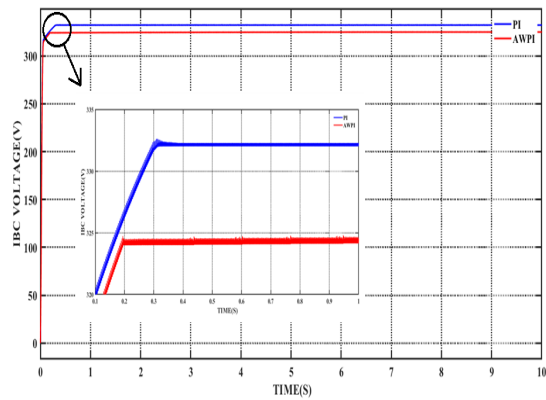

Figure 6 (a) IBC output voltage

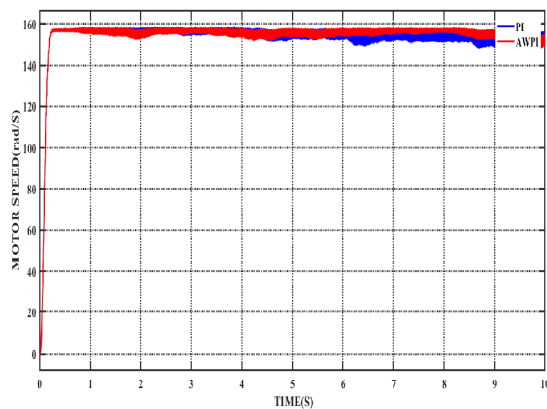

Figure 6 (b) Motor speed

Figure 6 Comparative performance of the proposed system under variable input voltage. From the comparative analysis, it is noted that there is some overshoot in the PI controlled voltage whereas no overshoot in AWPI controlled converter voltage. Speed ripple is also reduced by AWPI controller. Consider a case 2 where the input voltage is maintained as constant 24V. Comparative performance of PI and AWPI controllers in the aspect of a converter output voltage and voltage stress across the switching device is presented in figure 7.

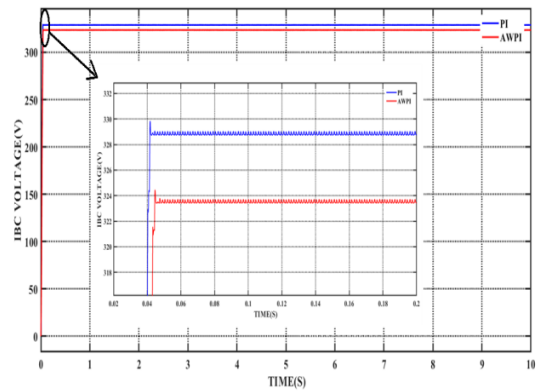

Figure 7 (a) IBC output voltage

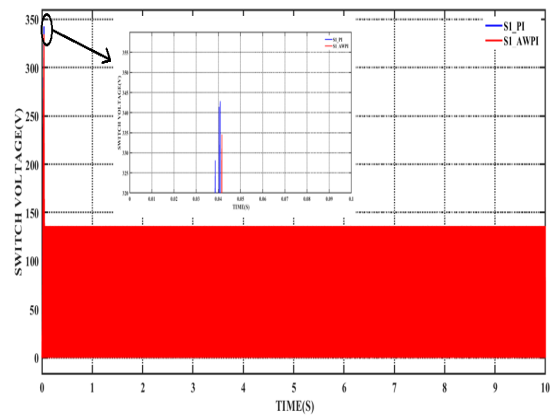

Figure 7 (b) voltage stress across the switching device

Figure 7 Comparative performance of the proposed system under constant input voltage

From figure 7 it is noted that voltage stress across the switch is reduced with the help of AWPI controller. Numerical analysis of controllers is presented in table 1.

Table 1 Comparative performance

Controllers	Overshoot (%)		Steady state error (%)		Settling time(s)	
	Case 1	Case 2	Case 1	Case 2	Case 1	Case 2
PI	0.3	0.27	2.5	1.23	0.32	0.32
AWPI	0.16	0.15	0.15	0.36	0.2	0.2

From table 1 it is noted that the AWPI controller improves the performance of the system in the aspects of overshoot, steady state

error and settling time compare to PI controller. From the analysis, it is noted whether the input is constant or variable the AWPI controller based system offers better performance than PI.

## 6. Conclusion:

Fuel cell powered Anti windup PI controlled interleaved boost converter with voltage multiplier has been analyzed with single phase induction motor load. Initially, the system is examined with PI controller based IBC in the aspects overshoot, steady state error and settling time. Voltage ripple in converter output results in ripples in the speed of induction motor. Proposed Anti windup PI controller based system reduces speed ripples and steady state error. It eliminated the overshoot in converter output voltage. AWPI controller offers the additional benefit of reduced voltage stress across the switch compared to PI. Hence the AWPI controlled proposed system effectively utilizes the fuel cell and improves the performance of motor for water pumping application.

## References:

1. Alzueta, Beatriz, Raquel Garde, and Mónica Aguado. "1 Residential fuel cells for distributed generation."
2. Aso, S., Kizaki, M., & Nonobe, Y. (2007, April). Development of fuel cell hybrid vehicles in Toyota. In *Power Conversion Conference-Nagoya, 2007. PCC'07* (pp. 1606-1611). IEEE.
3. Kosai, Hiroyuki, Seana McNeal, Austin Page, Brett Jordan, Jim Scofield, and Biswajit Ray. "Characterizing the effects of inductor coupling on the performance of an interleaved boost converter." *Proc. CARTS USA 2009* (2009): 237-251.
4. Huang, Xudong, Xiaoyan Wang, Troy Nergaard, Jih-Sheng Lai, Xingyi Xu, and Lizhi Zhu. "Parasitic ringing and design issues of digitally controlled high power interleaved boost converters." *IEEE Transactions on Power Electronics* 19, no. 5 (2004): 1341-1352.
5. Hu, Yanshen, Yunxiang Xie, Hao Tian, and Baoming Mei. "Characteristics analysis of two-channel interleaved boost converter with integrated coupling inductors." In *Power Electronics Specialists Conference, 2006. PESC'06. 37th IEEE*, pp. 1-6. IEEE, 2006.
6. Hu, Yanshen, Yunxiang Xie, Huamin Xu, and Hao Tian. "Design and implementation of two-channel interleaved boost converters with integrated coupling inductors." In *Power Electronics and Motion Control Conference, 2006. EPE-PEMC 2006. 12th International*, pp. 625-630. IEEE, 2006.
7. Thounthong, Phatiphat, Panarit Sethakul, Stéphane Rael, and Bernard Davat. "Design and implementation of 2-phase interleaved boost converter for fuel cell power source." (2008): 91-95.
8. Wen, Wei, and Yim-Shu Lee. "A two-channel interleaved boost converter with reduced core loss and copper loss." In *Power Electronics Specialists Conference, 2004. PESC 04. 2004 IEEE 35th Annual*, vol. 2, pp. 1003-1009. IEEE, 2004.
9. Wong, Pit-Leong, Peng Xu, P. Yang, and Fred C. Lee. "Performance improvements of interleaving VRMs with coupling inductors." *IEEE Transactions on Power Electronics* 16, no. 4 (2001): 499-507.
10. Jang, Yungtaek, and Milan M. Jovanovic. "Interleaved boost converter with intrinsic voltage-doubler characteristic for universal-line PFC front end." *IEEE Transactions on Power Electronics* 22, no. 4 (2007): 1394-1401.
11. Zhou, Luo-wei, Bin-xin Zhu, Quanming Luo, and Si Chen. "Interleaved non-isolated high step-up DC/DC converter based on the diode-capacitor multiplier." *IET Power Electronics* 7, no. 2 (2014): 390-397.
12. Lindahl, Peter A., Steven R. Shaw, and Steven B. Leeb. "Fuel Cell Stack Emulation for Cell and Hardware-in-the-Loop Testing." *IEEE Transactions*

*on Instrumentation and Measurement* (2018).

13. Wang, Caisheng, M. Hashem Nehrir, and Steven R. Shaw. "Dynamic models and model validation for PEM fuel cells using electrical circuits." *IEEE transactions on energy conversion* 20, no. 2 (2005): 442-451.
14. Li, Wuhua, Yi Zhao, Yan Deng, and Xiangning He. "Interleaved converter with voltage multiplier cell for high step-up and high-efficiency conversion." *IEEE Transactions on Power Electronics* 25, no. 9 (2010): 2397-2408.
15. Ghoshal, Anirban, and Vinod John. "Anti-windup Schemes for Proportional Integral and Proportional Resonant Controller." (2010).
16. Shin, Hwi-Beon. "New antiwindup PI controller for variable-speed motor drives." *IEEE Transactions on industrial electronics* 45, no. 3 (1998): 445-450.