

REAL POWER FLOW CONTROL OF 2 BUS MC-UPFC USING FUZZY LOGIC CONTROLLERS

¹C. Boopalan, ²V. Saravanan, ³T. A. Raghavendiran, ⁴S. Deepaprasath

¹Research Scholar, Anna university, Chennai India.

² Professor/EEE, Arunai Engineering College, Tiruvannamalai, India

³Dean, Sri Venakateswara Engineering college for women, Tirupathi, India

⁴Assistant Porfessor/EEE, C. Abdul Hakeem College of Engineering and Technology, Vellore, India

Correspondence Author : boopalan@annauniv.edu

Abstract

This paper deals with the design and testing of 2 Bus power system incorporated with Matrix Converter based Unified Power Flow Controller [MC-UPFC] to improve the transmission parameters such as real power and reactive power in both the generator side and the load side. The MC-UPFC is the rich topology in the Flexible AC Transmission System [FACTS] which is capable of controlling both the transmission parameters voltage injected and the angle of injection simultaneously with the switching technique of Direct power control by the smooth sliding control which gives less ripple in the injecting control parameters such as control voltage $[V_c]$ and voltage angle $[a]$. Hence the sliding surface and relevant control switching state of the MC can be controlled by the Fuzzy Logic Controller [FLC] which gives the robust and autonomous decision making in the selection of the appropriate switching state for the effective real power control in the power system. The work has been carried out in the MATLAB Simulink simulator which gives the finest controlling features and simple design procedures and easy monitoring of the output

Index terms: Matrix converter (MC), Unified power flow controller (UPFC), Fuzzy logic Controller (FLC).

INTRODUCTION:

In the modern Engineering world the demand of electricity is grown up and the quality concern of the electricity is also developed in the consumers mind because of the wide increase in electronic equipment usage in the day to day life. The power system which comprises of generation transmission and distribution has to be optimized for the effective utilization of the electric energy. The transmission system is the major observable area for the scope of research because the loss and quality is the major crisis in the system. Facts devices are the major solution providers in ensuring the distribution parameters [1-2].

There are various facts devices are available in the power system, among them UPFC is the device which is having more advantages over all other FACTS devices. UPFC comprises of two converters one connected in shunt with transmission and other converter is connected in series with the transmission line and both converters connected with the Direct Current link. UPFC is capable for real time control and dynamic compensation in AC transmission system [3-10].

The application of power electronics in power system makes the static and smooth control possible in power system. In the power electronics controllers the matrix converter has attracted more and more attentions due to the advantageous features such as sinusoidal input and output current control. Bidirectional energy flow controllable, lots of modulation techniques are available under which space vector based pulse width modulation technique with direct power control using sliding mode control is performing better. The matrix converter is placed in series with the transmission line. This results in the whole power being transmitted through MC thereby demanding higher device rating [11-17].

The matrix converter concept was first published in mid of 1970's. The circuit was considered to be a cycloconverter where the devices were fully controllable, which also called as forced commutation cycloconverter. Matrix converters are direct ac to ac converters that are used to convert available ac supply into desirable ac output with variable voltage and variable frequency. This converter are used for sinusoidal input/output current and voltages, input power factor control, regeneration capability, compact circuitry and less weight, Less noise. Works on direct duty ratio control. MC is more robust and reliable it can act as full converter. The direct Pulse width modulation control is implemented in this paper [18-24]. The MC-UPFC topology comes without any bulky reactive element except for lighter components such as bipolar switches. Thus reduces the cost. Construction is simple less components compared with conventional UPFC [25-26].

The fuzzy logic controller (FLC) is an adaptive control algorithm which is an emerging trend in the control and decision making system. In our proposed system the switching scheme based on the need of the controller will be provided by the FLC system as FLC based MC-UPFC. The complex space vector model is presented along with space vector PWM with fuzzy logic algorithm. The proposed FLC based MC-UPFC is a 3 limb 9 switches connected to the transmission system through a shunt and series transformer. The switching scheme of the MC is controlled by a FLC. The proposed system will precisely control the power flow by controlling the injecting bus voltage the injecting angle. Fuzzy system is designed using Fuzzy Inference System [21-29].

In the following sections the functioning and performance of FLC based MC-UPFC will be discussed.

SYSTEM MODELING:

UPFC WITH TRANSMISSION SYSTEM:

The proposed power system was represented in the figure: 1 consists of sending end and receiving end generators G_1 and G_2 respectively with the voltages V_{G1} and V_{G2} . The power system has a transmission line and it can be realized as an equivalent resistor and inductor in series namely R and L . The load is connected in the power system and represented with Z_L . The MC-UPFC was connected to the transmission line through a shunt transformer (T_{SH}) and series transformer (T_{SE}) to control the power system. The Fuzzy block is used to provide the switching control signals. The Power system parameters are measured in the buses namely B_1 and B_2 .

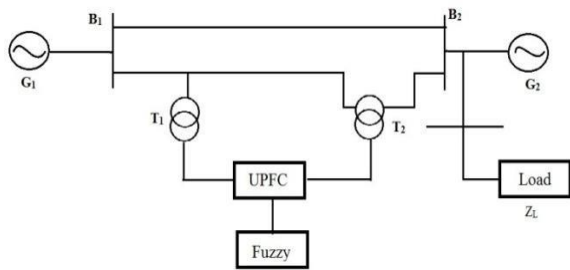

Figure:1 Power system with FLC based MC-UPFC

WORKING OF MC- UPFC SYSTEM:

Figure: 2 shows the reduced model of 3-phase MC-UPFC with a generator block named as generator with the voltage of V_g , MC-UPFC shown with its controlled injecting voltage V_c , transmission line represented with TL block and the line voltage as V_t , the influence of the

controlled injected voltage through the transformer is represented as V_s and it was fed to the impedance load shown as Z_L .

The voltage and current at various points and its direction can be understood with the help of the figure: 2. For system modeling, the Generating sources, series transformers and parallel transformers are all considered ideal. The matrix converter is constructed with the help of bi-directional ideal switches and represented as a controllable voltage source, The matrix converter is connected to transmission system with the input through parallel connected transformer and output through the series connected transformer. In the MC-UPFC all 9 bidirectional switches are arranged to ensure the possibility of each phase voltage can be feed to any phase by the controlled injected volt to the load independently. The real power of the system can be controlled injecting of voltage to the transmission system from the UPFC with two control parameter namely amplitude V_c and phase angle α .

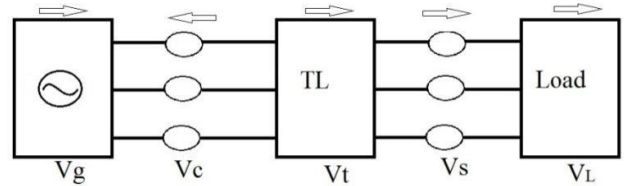

Figure:2 Equivalent circuit of MC-UPFC in Power system.

In our Proposed system the matrix converter will replace the three devices called shunt converter, dc-link and series converter. The MC-UPFC model has a major block as 3×3 a three limb 9 switch converter which can be controlled by a Direct Power control method to maintain the line real power. The switched voltage will be observed by the shunt transformer (T_{SH}) and injected through the series transformer (T_{SE}). The 9 bi-directional switches can turn ON and turn OFF according to the control signal. These switches allows any phase voltage to be injected to any phase in the transmissionline.

Applying the kirchoff's law to the UPFC transmission network, the power delivered can be estimated with the dq coordinates procedure.

$$I_d = \int \left((\omega I_q) - \left(\frac{R_2}{L_2} \right) I_d^2 + I \left(\frac{1}{L_2} \right) (V_{Ld} - V_{R0d}) \right) \quad (1)$$

$$I_q = - \int \left((\omega I_d) + \left(\frac{R_2}{L_2} \right) I_q - \frac{1}{L_2} (V_{Lq} - V_{R0q}) \right) \quad (2)$$

The simplified real power and reactive power can be equated with the power system parameter [19] as given below,

$$\text{Real power } P = V_d \cdot I_d \quad (3)$$

$$\text{Reactive Power } Q = -V_d \cdot I_q \quad (4)$$

The Error e_p is obtained from the difference between the pre-set reference power in per unit and the actual power available in the load bus B₂ the same procedure is applied to identify the e_q reactive power.

The stability conditions mentioned in equation (5) & (6), has to be satisfied to control the real and reactive power [19-21]. The sliding mode function $S(e_p, t)$ is quantized by the hysteresis comparator with three level as (-1),(0) and (+1), similarly $S(e_q, t)$ sliding mode reactive power error also obtained.

$$S_p(e_p, t) \cdot dS_p(e_p, t) < 0 \quad (5)$$

$$S_q(e_q, t) \cdot dS_q(e_q, t) < 0 \quad (6)$$

To control the real power in the load bus the following algorithm is implemented.

1. If $S_p(e_p, t) < 0 \Rightarrow \dot{S}_p(e_p, t) < 0 \Rightarrow P_{out} < P_{ref}$ to increase P.
2. If $S_q(e_q, t) < 0 \Rightarrow \dot{S}_q(e_q, t) < 0 \Rightarrow P_{out} > P_{ref}$
3. then chose vector suitable to increase P.
4. If $S_p(e_p, t) = 0 \Rightarrow P_{out} = P_{ref}$ then chose vector which un-change P. Where, P_{out} is actual power, P_{ref} is the reference power assigned to the controller.

To ensure smooth voltage injection sliding mode technique is implemented. To achieve the sliding mode voltage control, we need to select the right switch so that the voltage injection will give less transient peak over shoot in the load side. To understand the technique we need split the single cycle of the 3-phase voltage into 12 segments in time frame. To control with the space vector modulation we must need to know the actual instantaneous position of the waveform as to be identified [12-20].

$$\text{Control switch arrangement } C = \begin{bmatrix} c1 & c2 & c3 \\ c4 & c5 & c6 \\ c7 & c8 & c9 \end{bmatrix}$$

To ease the understanding of the switching state table, let we assume the matrix of switches are arranged as above (3x3) matrix 'C' with the switch numbers c1 to c9. The control the injecting voltage and angle 21 switching schemes are used and it was presented in the Table:1.

Switching state	Output voltage each phase			Switches in On state
	V _A	V _B	V _C	
1	A	B	B	1,5,6
2	B	A	A	4,2,3
3	B	C	C	4,8,9
4	C	B	B	7,5,6
5	C	A	A	7,2,3
6	A	C	C	1,8,9
7	B	A	B	4,2,6
8	A	B	A	1,5,3
9	C	B	C	7,5,9
10	B	C	B	4,8,6
11	A	C	A	1,8,3
12	C	A	C	7,2,9
13	B	B	A	4,5,3
14	A	A	B	1,2,6
15	C	C	B	7,8,6
16	B	B	C	4,5,9
17	A	A	C	7,8,3
18	C	C	A	1,5,9
19	A	A	A	1,2,3
20	B	B	B	4,5,6
21	C	C	C	7,8,9

Table: 1-sliding mode DPC switching state

For the execution of the above table the FLC will give the decision in terms of the switching sequence number and with reference to this the switching pattern will be switched in the matrix converter.

In case, if the switching state is "6" we need to switch on 1,8,9 switches in Matrix converter. input reactive power have to be considered for selection of switching states. The sign of the matrix reactive power Q_i can be determined by knowing the location of the output currents.

The possibilities of switching sequence based on the Voltage location, Current location and the sign of input reactive power is stated in the table:2.

Ca	Cb	I _{o12} & I _{o1}		I _{o2} & I _{o3}		I _{o4} & I _{o5}		I _{o6} & I _{o7}		I _{o8} & I _{o9}		I _{o10} & I _{o11}	
		Cqi(v1)		Cqi(v2)		Cqi(v3)		Cqi(v4)		Cqi(v5)		Cqi(v6)	
		P	M	P	M	P	M	P	M	P	M	P	M
L	H	19	24	21	24	20	21	20	23	23	22	22	19
L	Z	8	11	8	11	10	7	7	12	12	9	8	9
L	L	13	18	18	15	15	14	14	17	16	17	13	16
Z	H	19	24	19	24	20	21	20	23	23	22	8	19
Z	Z	9	10	15	19	17	18	10	9	19	20	17	18
Z	L	23	20	23	22	22	19	24	19	21	24	20	21
H	H	17	4	14	17	13	16	18	13	18	15	15	14
H	Z	12	7	12	9	8	9	11	8	10	11	10	7
H	L	23	20	23	22	22	19	24	19	21	24	20	24

Table: 2-sliding mode Sliding mode DPC switching state

Table: 2 illustrate the sample of switching scheme possibilities in each column. If sliding error of real and reactive power are quantized into three level called as high (H), low (L) and zero (Z). There will be 9 different combinational possibilities as mentioned in the column 1 and column 1 in the table: 2 as the voltage location was segmented into 12 regions each having 30 degree span from V1 to V12, similarly the output current location also segmented and named from I1 to I12. Based on the combinational possibilities switching patterns from 1 to 18 stated in the table: 1 is selected and if the error is zero then the null vector switching pattern can be selected which is highlighted from switching patterns from 19 to 21 in table: 1. To execute we need to switch on the switch number mention in the table-2. For example if the switching state is 7 we need to switch on (1,5,6) switches in Matrix converter.

MC-UPFC WITH FUZZY LOGIC CONTROL:

The power system proposed consists of a generator and the generated voltage is fed to the transmission line through the bus. The matrix converter with the 9 switches was connected through the shunt and series transformer. The UPFC can be controlled through the three phase relay which can be operated by the external control device so that the total UPFC system can be switched whenever it is required. At the end of the transmission line loads is which can receives the injected power parameters at the bus 2. The matrix converter is connected with the help of 9 bidirectional switches in three limbs operated by the switching schemes. The UPFC can be switched off/on with the timer based relay. A second order filter is connected in series with the UPFC to smoothen the injected power. A six winding three phase transformer with the transformer ratio $K=1$ is connected to the UPFC in parallel and the secondary winding of the transformer coil is connected in series with each phase so that the UPFC control voltage is

seriously injected to the transmission line to control the real power of the load. The external pulse is given to operate the UPFC with the time reference.

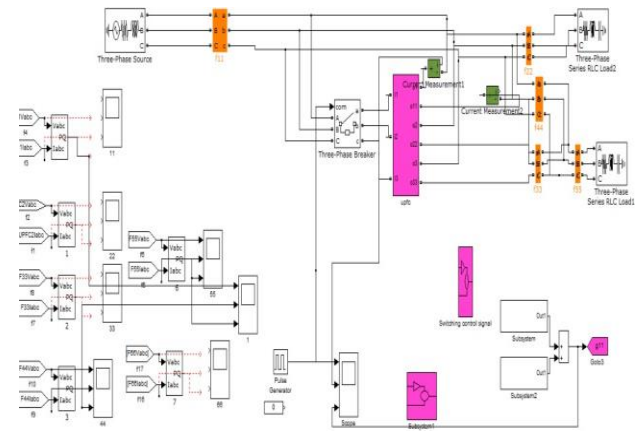

Figure : 3 Schematic diagram of a MC-UPFC

Control signal to the switches in the matrix converter is given through the selector switch in which the switching sequence have been feed with 21 different switching patterns. By feeding the control pattern number to the selector switch so that the power electronic switches operate accordingly.

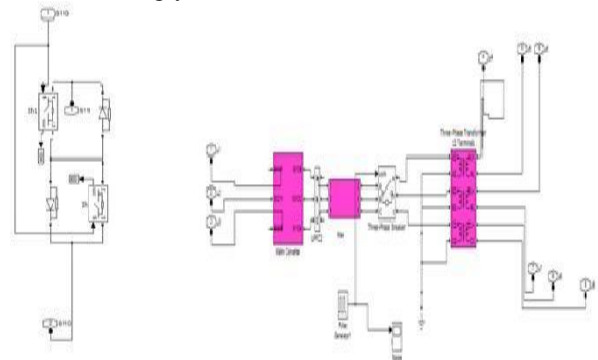

Figure: 4.(a) Bi-directional switch; (b) matrix converter with filter and series transformer.

Matrix converter is constructed with a bi-directional switch which is formed by two Insulated Gate Bi-polar Transistors (IGBT) switch connected back to back with a free-wheeling diode in anti-parallel connection as shown in the figure: (4.a) To form a matrix converter this kind of switch is connected in 3x3 matrix arrangement. Figure: (4.b) shows the matrix converter block and a filter arrangement to smoothen the ripple. The selector switching arrangement gives the switching state as shown in the equation (8).

$$\text{selector array} = [c1 \ c1 \ c3 \ c4 \ c5 \ c6 \ c7 \ c8 \ c9] \quad (8)$$

Case 1: to switch on the pattern “6 “ in the table 2 the output phase voltages will be available as given in the equations (9),(10) &(11).

$$\text{outupt phase 1} \Rightarrow V_{oA} = V_{iA} \quad (9)$$

$$\text{outupt phase 2} \Rightarrow V_{oB} = V_{iC} \quad (10)$$

$$\text{outupt phase 3} \Rightarrow V_{oC} = V_{iC} \quad (11)$$

To achieve the pattern “6” we need to switch on the switches 1,8,9 as shown below representations both in matrix format in equation (12) and selector switch input single array format.

$$\text{Control switch state 21 } C = \begin{bmatrix} 1 & 0 & 0 \\ 0 & 0 & 0 \\ 0 & 1 & 1 \end{bmatrix} \quad (12)$$

$$\text{selector array} = [c1 \ c1 \ c3 \ c4 \ c5 \ c6 \ c7 \ c8 \ c9] \quad (13)$$

WORKING OF FLC based MC-UPFC:

Fuzzy logic control based MC-UPFC based on direct power control having many advantages over the conventional ones. This controller has combined advantages of both fuzzy logic controller (FLC) and direct power controller based on space vector modulation. The FLC can work on non-linear system. The controller increases the robustness in the controlling system. There are two inputs for the fuzzy system and one output from it.

The two inputs to the FLC are injected voltage and its derivative. The input membership functions are designed using triangular shaped member functions (tri). The single output of the FLC is denoted by C-alpha and C-Beta and the output membership is designed by triangular shaped member function (tri). The corresponding membership functions are shown below.

A fuzzyfication is used to convert the input data into linguistic variable. A knowledge Base is data base with control rule set. A defuzzyfication interface which connects to a non-fuzzy control action.

The implementation of the fuzzy logic control based direct power control using sliding mode control using space vector modulation the input voltage (V_{in}) location and output Current (I_o) location has to be identified and it has to be correlated to 12 segments.

The actual power available in the controlled bus is measured and compared with the reference power given then error signal is calculated. The error signal was quantized using 3 level hysteresis comparator and it was mention as C-alpha. Similarly the reactive bus power has measured and compared with the reference signal and the error signal was quantized by using 3 level hysteresis comparator and denoted as C-beta.

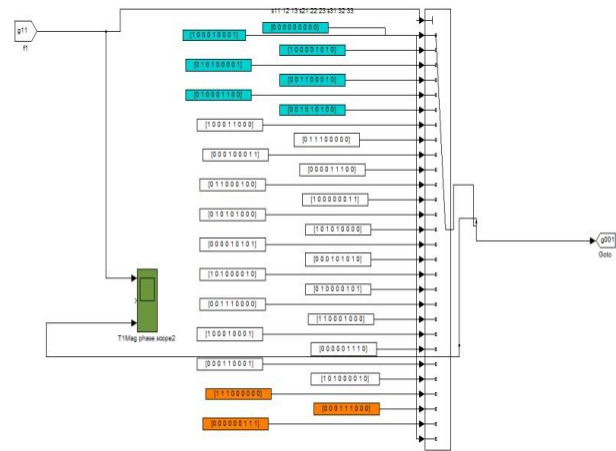

Figure-5 switching scheme selector switch.

Combination of C-alpha and C-beta can create 9(3x3) different possibilities and for each possibility we can match with the voltage segment (1-12) and current segment (1-12), based on the input reactive power error signal which has quantized into two level. Based on the above condition the switching state is selected and for the selection of the switching state fuzzy logic controller is implemented with two fuzzy controllers for real power control and reactive power control.

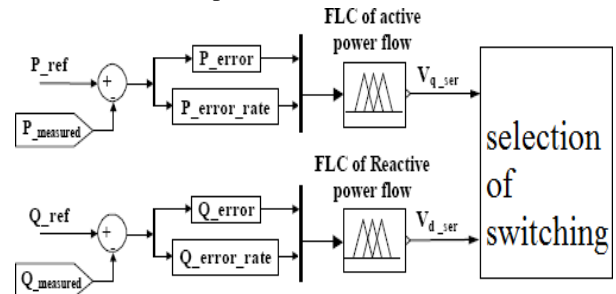

Figure: 6 block diagram of FLC in UPFC

The reference real power and reference reactive power will be fixed, the actual power quantities are measured and taken as input to the FLC as shown in the figure: 6, the direct errors and sliding surface errors $S_p(e_p, t)$ are measured and fed to the FLC which will give the switching state accordingly, and selector switch will select the switching state.

The figure: 7 shows the implementation of FLC in quantizing the real power with the direct power error and sliding mode error, The error signal are feed to the FLC and the output values varies from high , low and zero.

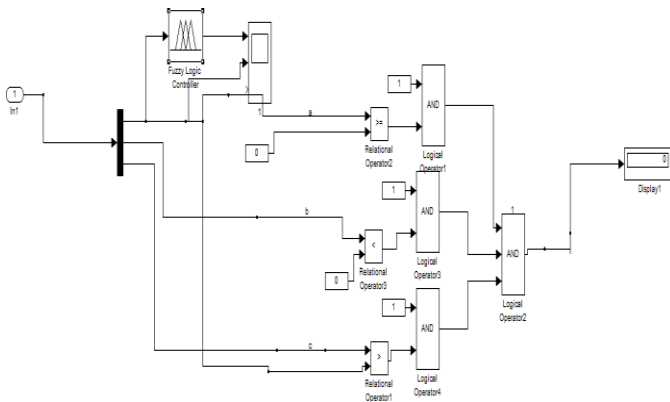

Figure:7 Implemented control circuit of FLC

To achieve the construction of FLC we need to frame the input membership functions as shown in the figure: 8(a). The member inputs are the direct power error quantities in real and reactive power. The membership functions are framed with triangular functions. The output functions are framed with the output member function as shown in the figure: 8(b).

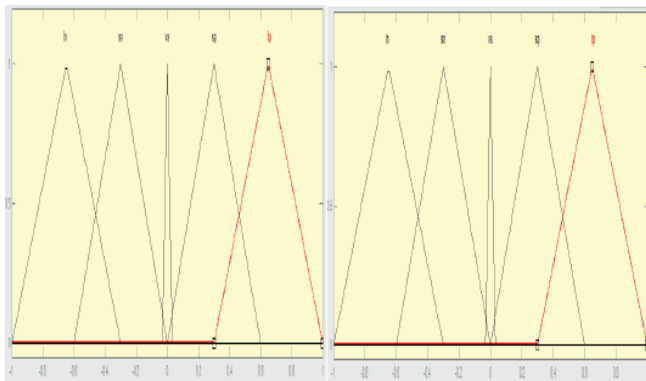

Figure: 8(a) FIS Fuzzy input member functions.

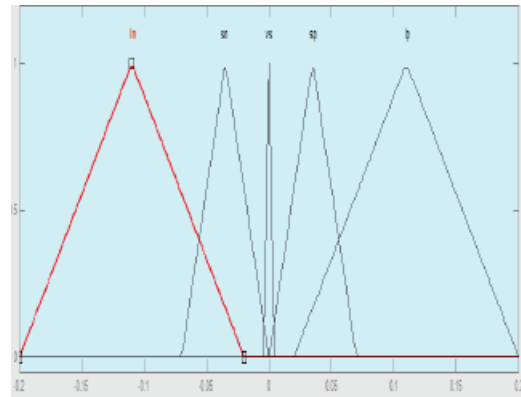

Figure: 8(b) FIS Fuzzy input member functions.

RESULTS:

The real power control in the 2 bus system is validated by constructing the simulation using MATLAB/Simulink Simpower System. The detailed design consisting of the blocks as matrix converter, generated voltage source, transmission system with shunt input transformer and series transformer with series filter is operated in the power graphical user interface. And its performance is monitored and highlighted with the input and output waveforms of the power parameters as input voltage, input current, real and reactive power. To reduce the simulation time Matrix converter was constructed with Ideal switches and the load with resistance and reactance as RL load is observed. With the resistive load the input power parameters are displayed in the figure: 9(a). the real power is constant also the reactive power. The output voltage and current wave form with the resistive load bus real and reactive power is shown in the output waveforms. Figure: 9 (b)

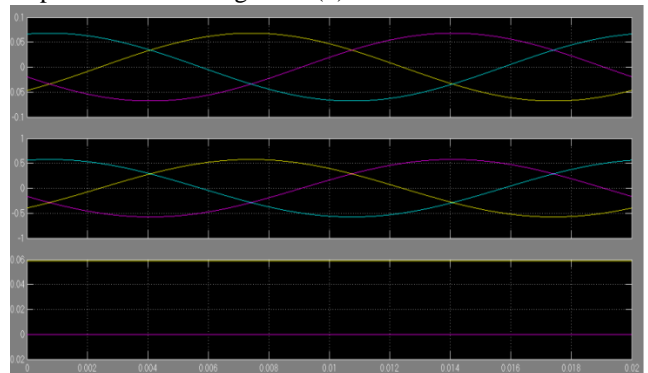

Figure: 9 (a) Input voltage, current, real power and reactive power.

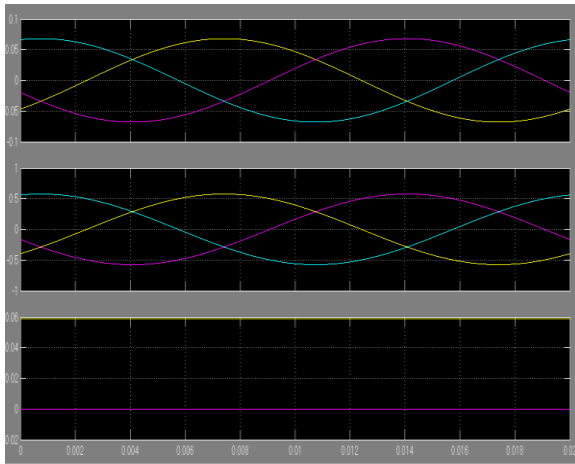

Figure: 9(b) Input voltage, current, real power and reactive power.

CONCLUSION:

In this paper, the real power flow control of the 2 bus transmission system is controlled using FLC based MC- UPFC is achieved with the sliding power control with direct power injection. Matrix converter based Unified Power Flow Controller has been developed using simulink tool Matlab simulator software. A efficient approach for designing Fuzzy logic controller for controlling the real power has been obtained for RL-impedance loading condition.. The use of MC-UPFC along with FLC provides better response and results in control of the real power with reference to the given reference power value in the power system.

In further this FLC algorithm can be developed for the 3 phase unbalanced loading condition. Also it has a scope of interconnected power flow controllers (IPFC).

REFERENCES:

1. L. Gyugi, C.D.Schauder, S.L. Williams, T.R. Rietman, D.R. Torgerson, A. Edris , "The Unified Power Flow Controllers: A new approach to Power Transmission Control", IEEE Trans. On Power Delivery, vol. 10, No.2 april 1995, pp.1085-1097.
2. I. Papic, P. Zunko, D. Povh, " Basic Control of Unified Power Flow Controller",IEEE Trans. On Power Systems, vol. 12, No. 4, November 1997.
3. K. R. Padiyar, A.M.Kulkarni, "Control Design and Simulation of Unified Power Flow Controller",IEEE Trans. On Power Delivery, vol. 13, No. 4, October 1998.

4. Hideaki Fujota, Yasuhiro Watanabe, Hirofumi Akagi, "Control and Analysis of Unified Power Flow Controller", IEEE Trans. On Power Electronics, vol. 14, No. 6, November, 1999.
5. H.F. Wang "Application of Modelling UPFC into mkulti-machine power system", IEE prac.-gener. Transm, Distrib., vol. 146, No. 3, May 1999.
6. Saeed Arabi, Prbhashankar Kundur, Rambabu Adapa, "Innovative Techniques in Modeling UPFC for Power System Analysis", IEEE Trans. On Power System, vol. 15, No. 1, February 2000.
7. Liming Liu, Pengcheng Zhu, Yong Kang, Jian Chen, " Power-Flow Control Performance Analysis of a Unified Power Flow Controller in Novel Control Scheme", IEEE Trans. On Power Delevery, vol.22, No.3, July
8. Amin Mohammadpour shotorbani, Ali Ajami, Saeed Gassem Zadeh, Mohammad Pourmahmood Aghababa, Behzad Mahboubi, IET Gener. Transm. Distrib., 2014. Vol. 8, Iss. 10, pp. 1712-1723.
9. Jiazin Yuan, Lei Liu, Wenli Fei, Li Chen, Baichao, "Hybrid Electromagnetic Unified Power Flow Controller: A Novel Flexible and Effective Approach to Control Power Flow", IEEE Trans. On Power Delivery.
10. Sauvik Biswas, Paresh Kumar Nayak "State-of-the-art on the protection of FACTS compensated high-voltage transmission lines: a review", IET trans. On High Volt., 2018, vol. 3 iss. 1.
11. Boon-Teck Ooi, Mehrdadkazerani, " Voltage-source Matrix Converter as a Controller in Flexible AC Transmission Systems", IEEE trans. On Power Delivery, Vol. 13, No. 1, January 1998.
12. Patrick Wheeler, Jon Clare, Lee Empringham, Maurice Apap, Michael Bland, " Matrix Converters", Power Engineering Journal, December 2002.
13. Rajan K. Gupta, Krushna K. Mohapatra, Apurva Somani, Ned Mohan, " Direct-Matrix-Converter-Based Drive for a Three-Phase Open- End-Winding AC Machine With Advanced Features", IEEE Trans. On Industrial Electronics, Vol.57, No. 12, December 2010.
14. Atif Iqbal, SK Moin Ahmed, Haitham Abu-Rub, " Space Vector PWM Technique for Tree-to-Five-Phase Matrix Converter",IEEE Trans. On Industry Application, Vol. 48, No.2, Mar/Apr 2012.
15. Matias Diaz, Roberto Cardenas, Felix Rojas, Jon Clare, "3-Phase 4-wire matrix converter-based voltage sag/swell generator to test low- voltage ride through in wind energy conversion systems. IET power electronics, 2014, Vol.7, Iss 12, pp, 3116-3125.
16. Mohammad Ali, Atif Iqbal, M. Rizwan Khan, Mohammad ayyub, Mohd. Anas Anees, "Generalized Theroy and Analysis of Scalar Modulation Techniques for A mxn Matrix Converter", Trans. On Power Electronics, 2016.
17. Yao Sun, Wenjing Ziong, Mei Su, Xing Li, Hanbing Dan, Jian Yang, "Carrier-Based Modulation Strategies for Multimodular Matrix Converters", IEEE Trans. On Industrial Electronics, vol.63, No. 3, march 2016.

18. Anindya Dasgupta, Praveen Tripathy, Partha Sarathi Sensarma, "Matrix Converter as UPFC for Transmission line Compensation", October 22-2, 2007/ EXCO, Daegu, Korea.
19. J. Monterio, J. Fernando Silva, S.F. Pinto, J. Palma. "Matrix Converter-Based Unified Power Flow Controllers: Advanced Direct Power Control Method", IEEE Trans. On Power Delivery, vol. 26, No.1, January 2011.
20. J. Monterio, J. Fernando Silva, S.F. Pinto, J. Palma. "Linear and Sliding-Mode Control Design for Matrix Converter-Based Unified Power Flow controllers", IEEE Trans. On Power Electronics, vol. 29, No. 7, July 2014.
21. Felipe Villarroel, Jose R, Espinoza, Christian A. Rojas, Jose Rodriguez, Marco Rivera, Daniel Sabrbaro. "Multi objective Switching State Selector for Finite-States Model Predictive Control Based on Fuzzy Decision Making in a Matrix Converter", IEEE Trans. On Industrial Electronics, Vol. 60, No. 2, February 2013.
22. D. Sri Vidya, Dr. T. Venkatesa, "Quasi-Z-Source Indirect Matrix Converter Fed Induction Motor Drive for Flow Control of Dye in Paper Mill. IEEE Trans. On Power Electronics, 2017.
23. D. Menniti, A. Pinnarelli, N. Sorrentino, "A Novel fuzzy logic controller for UPFC", IEEE, 2000.
24. M.E.A. Farrag, G.A. Putrus, L. Ran, "Design of Fuzzy Based-Rules Control System for the Unified Power Flow Controller", IEEE, 2002.
25. Aihong Tang, Youzin Yuan, Shijie Cheng, "The Study of Fuzzy-Logic Self-Adaptive Controller for UPFC", IEEE, 2008.
26. Chinnari Eswar Prasad, Shelly Vadhera, "Damping of Sub Synchronous Resonance Using Fuzzy Based PI Controlled UPFC", IEEE, 2015.
27. Ravinder Kumar, Mahendra Kumar, "Improvement Power System Stability Using Unified Power Flow Controller Based on Hybrid Fuzzy Logic-PID Tuning In SMIB system. IEEE 2015.
28. Asit Mohant, Sandipan Patra, Prakash K. Ray, "Robust fuzzy-sliding mode UPFC controller for transient stability analysis in autonomous wind-diesel-PV hybrid system", IET Gener. Trans. Distrib., PP. 1-10.
29. Fadi M. Albatsh, Saad Mekhelef, Shameem Ahmad, Hazlie Mokhils, "Fuzzy Logic Based UPfc and Laboratory Prototype Validation for Dynamic Power Flow Control in Transmission Lines", IEEE Trans. On Industrial Electronics.