

A Novel Strategic Approach to Enhanced High Performance Evaluation of IDVR and IPFC

E. Anbarasu¹ and S. Muthu Vijaya Pandian²

¹Research Scholar, Department of Electrical and Electronics Engineering, Anna University, Chennai.

²Professor, Department of Electrical and Electronics Engineering, SNS College of Technology, Coimbatore, Tamil Nadu
Email - anbarasu.e08@gmail.com

Abstract —This paper initiates a comprehensive comparison strategy among the Interlined Power Flow Controller (IPFC) and Interline Dynamic Voltage Restorer (IDVR). The fundamental operation of IDVR and IPFC has compared. The transmission line performance with IDVR and without IDVR presented in a strategic manner and result analysis made for further comparison with IPFC. The MATLAB/Simulink based model developed for IDVR and IPFC; the output response of the system has compared and an awesome conclusion proposed.

Index Terms--- Power Quality (PQ), Unified Power Quality Conditioner (UPQC), Dynamic Voltage Restorer (DVR).

I. INTRODUCTION

Nowadays Flexible AC Transmission Systems (FACTS) controllers are playing a vital role in terms of power flow control, transient stability and oscillation damping enhancement as reported in [1-3]. Researchers have presented design of FACTS-based stabilizers for SVC, TCSC, TCPS, and Unified Power Flow Controller (UPFC) in [5]. Interline Power Flow Controller (IPFC) is an advanced voltage sourced Converter based FACTS controller [2] which employs a number of dc to ac converters each providing a series compensation for a different lines. VSC-based FACTS controllers include the Static Synchronous Compensator (STATCOM) for shunt reactive power compensation, the Static Synchronous Series Compensator (SSSC) for series reactive power compensation, the Unified Power Flow Controller (UPFC) with the unique capability of independently controlling both the active and reactive power flow in the line. Generally speaking, the IPFC employs a number of VSCs linked at the same DC terminal, each of which can provide series compensation for its own line. It can also be regarded as several SSSCs sharing a common DC link. In this way, the power optimization of the overall system can be realized in the form of appropriate power transfer through

the common DC link from over-loaded lines to under-loaded lines [7].

An IDVR, which is two DVRs installed in two feeders with common dc bus, has the capability of active power exchange between two DVRs, and thus the energy storage device is not an issue. Therefore, the design criteria for the Selection of rating of an individual DVR are not applicable in IDVR structure. Voltage sags are one of the worst power quality disturbances that cause a lot of damage to customer's particularly industrial ones. These disturbances, mainly due to faults and start-up of large loads [9], are normally Characterized by the number of occurrences, the amplitude and the duration of sag [10]. IDVR consists of several DVRs on different distribution lines sharing a common DC link.

References [11 12] discuss the two-line IDVR system. The system utilizes the pre-sag compensation method to mitigate the voltage sag problem in one feeder provided that the voltage of the other is normal. A novel minimal energy consumption strategy for the IDVR is proposed in [12] where two different voltage distribution systems are protected using two DVRs. The first is a low voltage DVR operating in voltage sag mitigation mode injecting active power from the DC link capacitor. Simultaneously, the other medium voltage DVR keeps the voltage of the DC link capacitor constant. In [13], the optimum rating for two DVRs when used for IDVR system is designed An IDVR is similar to the inter line power flow controller (IPFC) in transmission systems [11] but to distribution systems. In this paper a performance comparison among interline power flow control and interline dynamic voltage restorer has presented. The approach carried out with application of performance of the system with IPFC and IDVR made and result analysis presented in the system.

Operational behavior of Interline Power Flow controller (IPFC):

The interline power flow controller shown in fig (1) consist of two VSCs, each of which located series in the lines with

their DC sides connected via a common capacitor. For the purpose of modeling the IPFC, it is considered in the form of several VSCs which have common DC connections. In IPFC design, assuming that it has two VSCs, one line is always selected as the main line and another line which is connected to the IPFC is considered as the dependent or lower line. In the main line, the active and reactive powers are both manageable entirely, and can adjust them to the desired value, but in the dependent or lower line, only one of the active or reactive powers is controllable, and the other is released. The important property of IPFC that can transmit power from overloaded lines to under loaded lines. It can be easily indicated that in the main lines, the active and reactive powers are completely controllable, and the control strategy can be achieved by changing the amplitude and angle of series converter voltage.

Operational behavior of Interline Dynamic Voltage Restorer (IDVR):

The IDVR system consists of several DVRs in different feeders, sharing a common DC-link. A two-line IDVR system shown in Figure 3 employs two DVRs are connected to two different feeders where one of the DVRs compensates for voltage sag or swell produced, the other DVR in IDVR system operates in power-flow control mode. Firstly, unlike individual DVRs, the duration of compensation in an IDVR is not usually restricted. The reason is that the required energy for compensation comes from another feeder, which is supposed to be healthy. However, energy absorption from the healthy feeder via dc link may cause overload and

unacceptable sag in the healthy feeder. Therefore, some inherent limitations always exist which depends on feeder parameters and the depth of sags, but not on the duration of sags. Based on this reasoning, minimum energy strategy is not necessarily applicable in compensation, and it may lead to larger rating and over-size DVR.

II. VOLTAGE SAG COMPENSATION IN A TWO FEEDER IDVR SYSTEM

The voltage sag in a two-feeder IDVR system is caused due to sudden increase of the load across a feeder. Consider the condition when the DVR in the IDVR system operates in Voltage-sag compensating mode while the DVR operates in power-flow control mode to keep the DC-link voltage at a desired level. When there is no voltage disturbance, the load voltage of Feeder is equal to the bus voltage V during Voltage sag, the DVR should be operated to meet this condition while supplying real power to the common DC-link. The harmonic elimination in any system is one of the important requirements nowadays. The total harmonic distortion in the response obtained can be reduced abruptly with interline dynamic voltage restorer.

III. RESULT ANALYSIS OF IDVR AND IPFC

From the simulink model proposed (fig 1); the interline power flow controller designed with two transmission lines of 50 KM each ; phase to phase RMS voltage (V_{rms}) = 10 KV

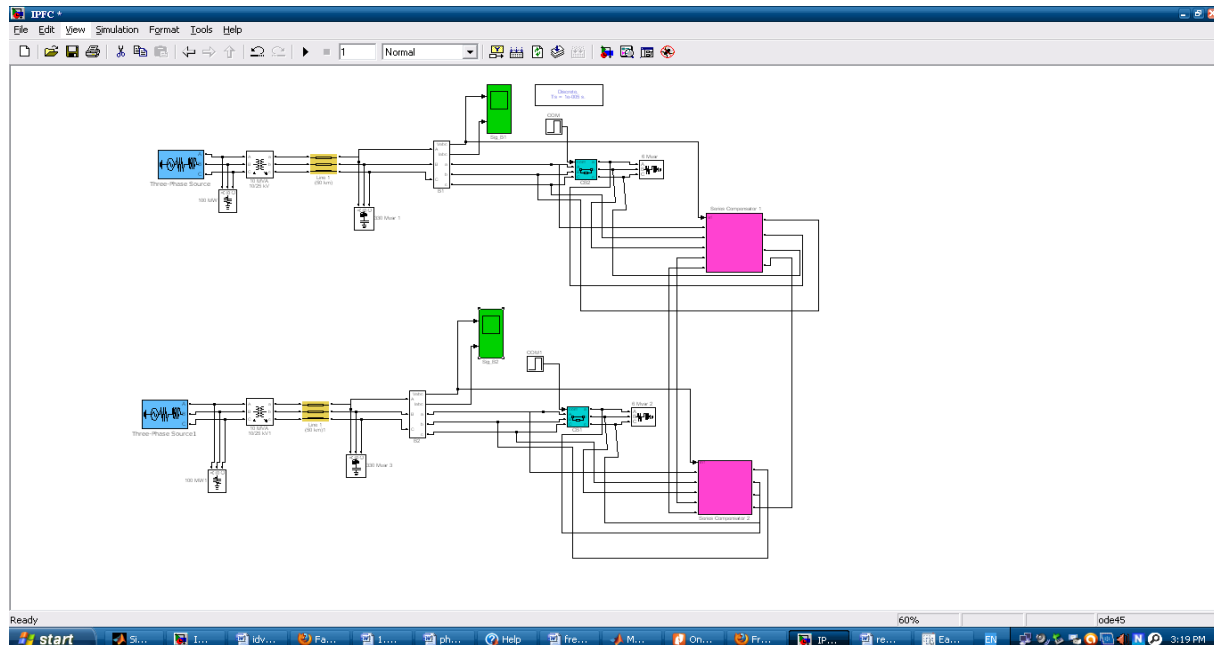

Fig. 1: The IPFC with two series compensators

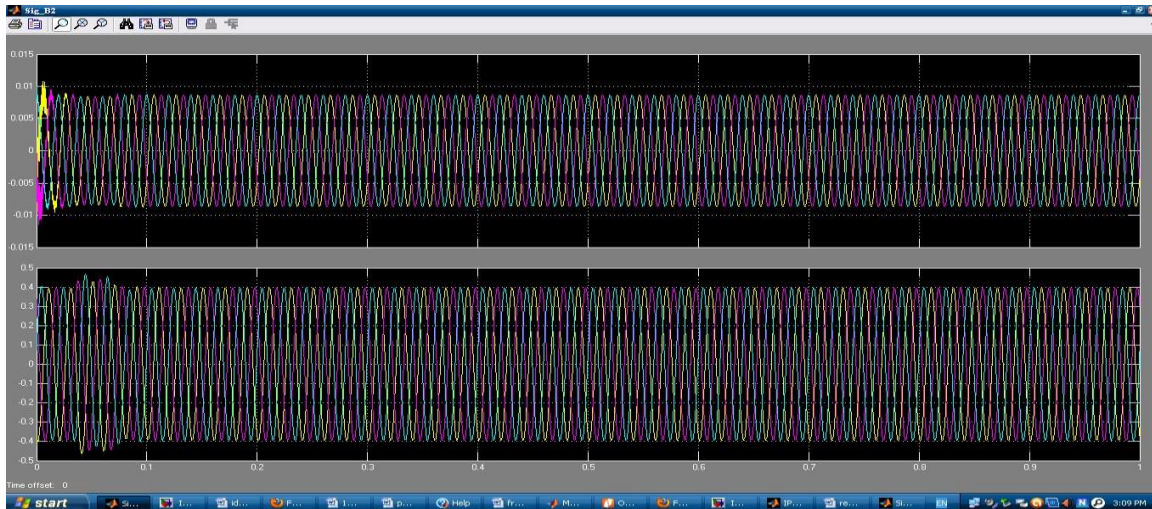

Fig. 2: Voltage and current response of the system

The partially controlled three phase voltage and current (V load; I load) response of system when ipfc is applied has given (in fig.2)

An IDVR model is presented with a line length 300 kilo meters; a three phase rms voltage of 13.8 KV; Three phase transformer with 6*350 MVA, 13.8/735 kv in fig.3

The distorted condition of load voltage and current appear when the IDVR is not added as in fig.4 and the fault mitigated voltage and currents are shown in fig 5 with the application of IDVR.

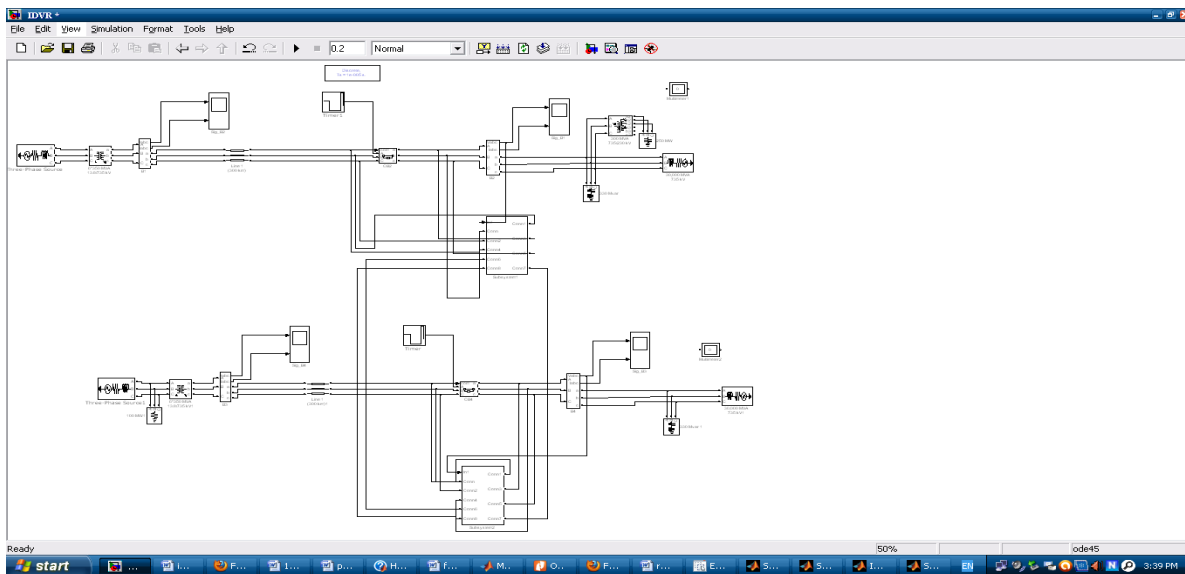

Fig. 3: Interline Dynamic Voltage Restorer (IDVR) with two DVR s in the line.

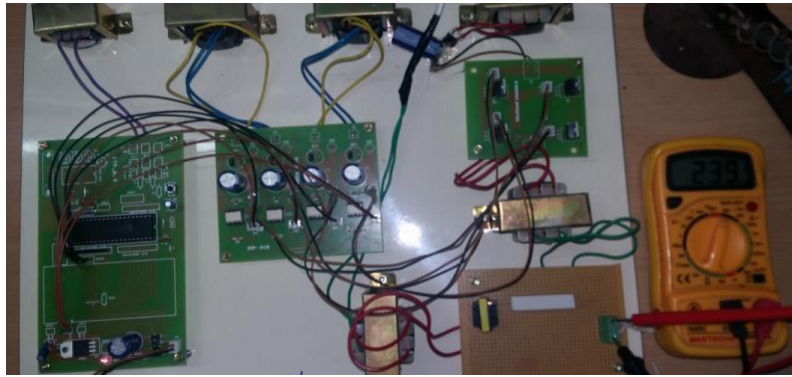

Fig. Experimental Setup for IDVR

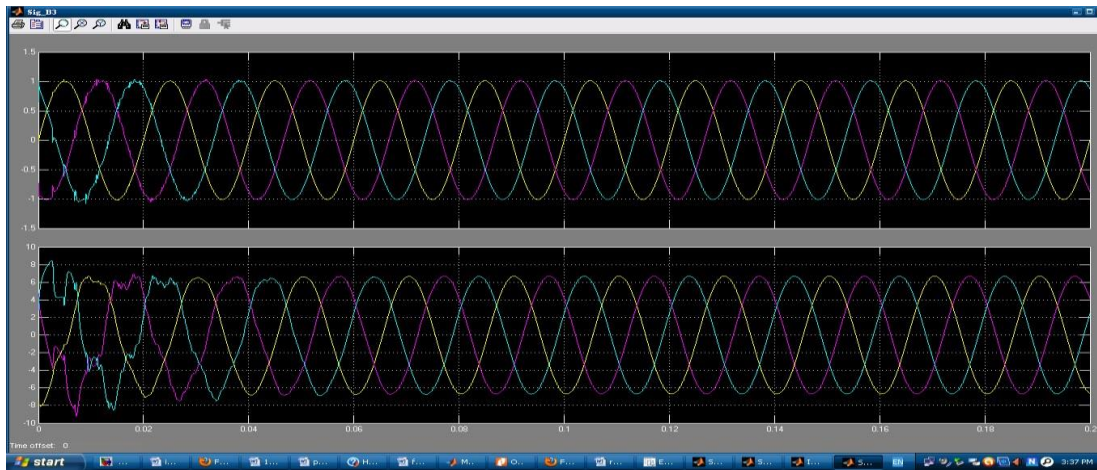

Fig 4. The output response (V load; I load) of the model when the IDVR is not added

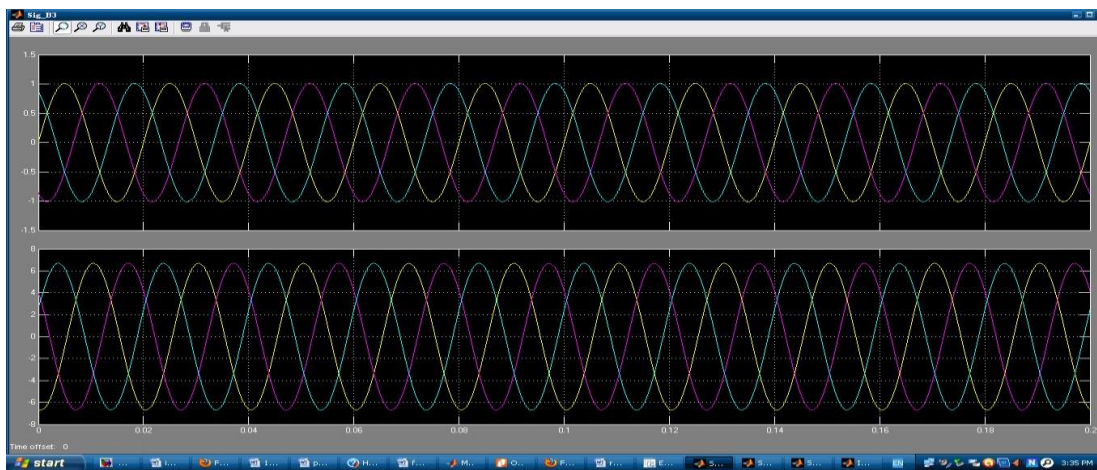

Fig.5.The stabilized output response (V load; I load) when IDVR is added in the model

IV. CONCLUSION

In this paper a comprehensive performance analysis among interline dynamic voltage restorer and interline power flow controller presented. The operation behavior of the IDVR and IPFC starting from fundamental structure has carried out in an effective manner. Observation of the load response presented in order to give effective comparison between IDVR and IPFC Experimental setup and Matlab/simulink models.

REFERENCES

- [1] R. Sadikovic, P. Korba and G. Andersson, "Application of FACTS Devices for Damping of Power System Oscillations," IEEE PowerTech 2005, Russia, June 2005.
- [2] P.K.Dash, S.Mishra, G.Panda, "Damping Multimodal Power System Oscillation Using a Hybrid Fuzzy Controller for Series Connected FACTS Devices," IEEE Transactions on Power Systems, Vol. 15, No. 4, November 2000, pp. 1360 – 1366. H.F. Hang, "Design of SSSC Damping Controller to Improve Power System Oscillation Stability," IEEE 1999.
- [4] N.Tambey and M.L.Kothari, "Damping of Power System Oscillation with Unified Power Flow Controller," IEE Proc. Gener. Trans. Distrib. Vol. 150, No. 2, March 2003, pp. 129 – 140.
- [5] N.G. Hingorami, L.Gyugyi, Understanding FACTS: Concepts and Technology of Flexible AC Transmission system, IEEE Press, 1999 [6] Y.H. Song and A.T. Johns, Flexible AC Transmission systems, IEE Power and Energy series 30, 1999.
- [6] L.Gyugyi, K.K.Sen, C.D.Schauder, "The Interline Power Flow Controller Concept: A New Approach to Power Flow Management in Transmission Systems," IEEE Transactions on Power Delivery, Vol. 14, No. 3, July 1999, pp. 1115 – 1123.
- [7] J. Chen, T.T. Lie, D.M. Vilathgamuwa, N.G.Hingorani, L.Gyugyi, "Understanding FACTS: concepts and technology of flexible AC transmission system", IEEE PRESS, 2000.
- [8] Y.H. Song and A.T. Johns, "Flexible AC Transmission System", IEE R Book Series on Power Engineering, December 1999.
- [9] L.Gyugyi, "Application Characteristics of Converter-Based FACTS Controllers", International Conference on PowerCon 2000, Vol.1.
- [10] L.Gyugyi, K.K.Sen, C.D.Schauder, "The Interline Power Flow Controller Concept: A New Approach to Power Flow Management in Transmission Systems", IEEE/PES Summer Meeting, Paper No. PE316-PWRD-0-07-1998,
- [11] L.Gyugyi, K.K.Sen, C.D.Schauder, "The Interline Power Flow Controller Concept: A New Approach to Power Flow Management in Transmission Systems", IEEE Transactions on Power Delivery, Vol. 14, No. 3, pp.1115-1123, July 1999.
- [12] Math H. J. Bollen, Understanding Power Quality Problems: Voltage Sags and Interruptions, Wiley, 1999.
- [13] Yashomani Y. Kolhatkar, and Shyama P. Das,; —Experimental Investigation of a Single-Phase UPQC With Minimum VA Loading|| IEEE TRANSACTIONS ON POWER DELIVERY, VOL. 22, NO. 1, JANUARY 2009 PP 373-380.
- [14] Dušan Graovac, Vladimir Kati, Alfred Rufer, Jovan Kneevi, —Unified Power Quality Conditioner Based on Current Source Converter Topology||, EPE 2010 – Graz, P1-P9. [48] L.H. Tey, P.L.So, Y.C.Chu, —Unified Power Quality Conditioner for Improving Power Quality Using ANN with Hysteresis Control||, International conference on power system- POWERCON 2009, 21-24 November 2004, pages: 1441-1446.
- [15] Metin Kesler, Engin Ozdemir, " A Novel Control Method for Unified PowerQuality Conditioner (UPQC) Under Non-Ideal Mains||, IEEE Conference, 978-1-4244-4783-1/10/\$25.00 ©2010 IEEE.[16] J. G. Nielsen, M. Newman, H. Nielsen, and F. Blaabjerg,—Control and testing of a dynamic voltage restorer (DVR) at medium voltage level,|| IEEE Trans.Power Electron.,vol. 19, no. 3,p.806,May 2004.
- [16] Rosli Omar And Nasrudin Abd Rahim " Modeling and Simulation for Voltage Sags/Swells Mitigation Using Dynamic Voltage Restorer (DVR)" 2008 Australasian Universities Power Engineering Conference (AUPEC'08).
- [17] Fawzi AL Jowder —Modeling and Simulation of Dynamic Vltage Restorer (DVR) Based on Hysteresis Vltage Control|| The 33rd Annual Conference of the IEEE Industrial Electronics Society (IECON) Nov. 5-8,2007,Taipei,Taiwan.