

# Assessment of Load Frequency Control of Three Area Interconnected Power System using Fuzzy Gain Scheduling controller

D. Revathi<sup>1</sup> G. Mohan Kumar<sup>2</sup>

<sup>1,2</sup>Park College of engineering and technology, Tamil Nadu, India, revathivasagam@gmail.com

## Abstract:

Fuzzy Gain Scheduling controller in load frequency control of three area electric power system is proposed in this paper. The three area interconnected thermal power plant is analyzed in this article. With the growth of power system capacity and size, it is often observed that huge tie-line power divergence and continued power fluctuation under sudden system load changes result in instability. Traditional PI controller is analyzed for stability by many researchers in load frequency control, but it does not satisfy the stability of the system. It demands the proposal of advanced PI controllers like Anti-windup PI and Fuzzy Gain Scheduling controller. The principle of the Anti-windup PI controller is based on avoiding the unwanted Windup phenomenon of Proportional Integral controller. The working of the Fuzzy Gain Scheduling controller is based on the auto tuning of gains of the Proportional Integral controller. The performance of traditional PI controller and proposed controllers are compared under small step disturbance using MATLAB / Simulink. Impacts of load disturbance on tie line power and frequency are analyzed.

**Keywords:** Load Frequency Control, Thermal-Thermal-Thermal interconnected power system, PI, Anti-windup PI, Fuzzy Gain Scheduling controller.

## 1. Introduction

Power quality is the most important prospect of electricity consumption. In maintaining the quality of power, Frequency plays a vital role. In a large scale power system based on load demand, many power plants are interconnected to meet the demand via tie line. When multi power systems are interconnected, it is crucial maintaining power flow in tie line and frequency without variations even in the case of load disturbance. Load varies incessantly based on the necessity of the consumer.

The abrupt change in the load deviates the frequency of the power system. Frequency change in power system causes power deviation at different rates in the multi system results in power flow in tie

line. To guarantee the stability of the system Load Frequency Controller is implemented in power generation control [1, 2]. Load Frequency Control (LFC) is significant to remain the system frequency and the inter-area tie power maximum possible the programmed values in an interconnected power system [3, 4]. A reliable power system should offer quality power as far as voltage and frequency even the existence of system disturbances and changes in the load. During Load variation, LFC controls by different control techniques such as PI modified PI controller to control the power generation to meet the load demand. It consistently monitors the load demand and distributes the load based on the rating of the system.

The load frequency control can be done by using a conventional PI controller. Despite the fact that the PI controller diminishes the steady state error delivers an overshoot which drives frequency variations [5, 6]. Overshoot is an effect of an integral windup phenomenon in a PI controller. In this paper integral windup problem is controlled by introducing anti-windup action in a PI controller [7]. In various applications such as motor drives and positioning etc., the anti windup PI controller produces effective performance [8, 9]. In an interconnected power system, load variations and disturbances are the fuzzy data in the view of the controller. Normally for processing with inaccurate data, the fuzzy logic controller is best [10, 11] choice of controller. To deal with inaccurate data in this article fuzzy gain scheduling controller is proposed for LFC in the Thermal-Thermal interconnected power system. In 1993 Fuzzy Gain Scheduling controller was introduced for process control application [12]. From various researches, it is noted that Fuzzy Gain Scheduling controller is an optimum choice for the linear and nonlinear system [13-15].

A. Selk Ghafari and A. Alasty analyzed an improved micro stepping operation of hybrid stepper motor drive using fuzzy gain scheduling controller [16] with experimental validation. Fuzzy gain scheduling controller is analyzed for various

applications such as non-linear control, Multi input multi output process control system and etc. [17]. The processing time of fuzzy gain scheduling controller is decided by the number of rules which is less than existing optimization techniques. In this article LFC for three area thermal power system is analyzed with the help of AWPI and FGS controller

## 2. Thermal-Thermal-Thermal Interconnected Power System

The typical block diagram of three areas interconnected thermal-thermal-thermal power system is presented in fig 1. Frequency deviations in systems 1-3 such as ( $\Delta f_1$ ), ( $\Delta f_2$ ), ( $\Delta f_3$ ) and tie line power deviation ( $\Delta P_{tie}$ ) are the main parameters analyzed to evaluate the performance of the power system. To analyze the response of the proposed system perturbation is introduced in all areas.

In a LFC manual control is replaced by the closed loop control system. The objective of the LFC is to eliminate the steady-state frequency error and tie line power deviation created by the load perturbation. Every system controls them and supports another system which cannot manage its individual variances.

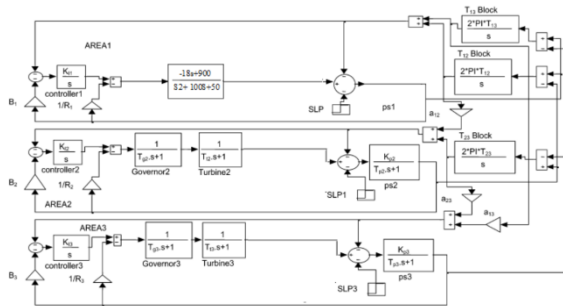

Fig.1. Three Areas interconnected thermal-thermal-thermal System with LFC

In thermal systems, active power generated is determined by the speed of the turbine, while speed is regulated by Speed governor. Equation (1) states the function of speed governor in terms of frequency deviation. Lack of power in that system causes frequency deviation in a system. A function of LFC is to sense the frequency deviation controls the turbine speed to assure the requirement, which automatically regulates the frequency. A flow of steam determines the turbine power. In this paper by reason of reliable and flexible design a single nonreheat turbine is utilized. Governing equation of nonreheat turbine is expressed as (2).

$$\Delta P_g(s) = \Delta P_{ref1}(s) - \frac{1}{R_1} \Delta f_1(s) \quad (1)$$

Where Speed regulation of thermal systems are  $R_1$  and  $R_2$

$$\Delta P_T(s) = \frac{1}{1 + sT_T} \Delta P(s) \quad (2)$$

Where  $T_T$  is the Non reheat turbine time constant

Load perturbation modifies the power generated. Equation (3) shows a deviation

$$\Delta P_T(s) - \Delta P_{D1}(s) = \frac{K_p}{1 + sT_p} \Delta f_1(s) \quad (3)$$

Where the Power system time constant is  $T_p$ , and  $K_p$  is the Power system gain parameter.

Three Thermal systems are associated through the interconnection named as Tie line [18]. It supports the relentless supply to the load. The equation of tie line is expressed as

$$\Delta P_{tie,1,2} = \frac{2\pi T}{s} (\Delta f_1(s) - \Delta f_2(s)) \quad (4)$$

## 3. PI controller for LFC

PI controller is a simple controller massively applied in various applications of the power system. This simple controller takes minimum time to respond. Steady state error is condensed efficiently by utilizing the PI controller. In LFC, Area Control Error (ACE) is taken as input to PI controller. The PI controller equation is as follows

$$U(s) = K_p E(s) + \frac{K_i}{s} E(s) \quad (5)$$

Where  $K_p$  and  $K_i$  are the gains of the controller,  $E(s)$  and  $U(s)$  are the input and output of the controller. Fig 2 shows the simulation model of the PI controller.

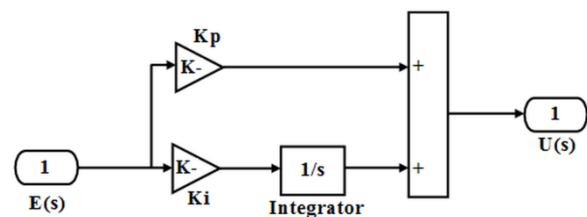

Fig.2. PI controller

The  $K_p$  &  $K_i$  values are tuned using Ziegler-Nichols' method. As discussed in an introduction section PI controller results high overshoot and long settling time.

#### 4. Anti-windup PI controller for LFC

From the name itself, it is clear that Anti-Windup PI (AWPI) controller compensates unwanted Windup phenomenon produced by the integral controller. So that the large overshoot produced by the controller is reduced. The anti-windup PI controller is applied in LFC system to reduce peak overshoot in frequency oscillation and its settling time. The working of the AWPI controller resembles the PI controller except that the integral controller has feedback from the output. There are several methods in an anti-wind up pi controller such as AWPI conditioned, AWPI with the dead zone, AWPI with tracking and AWPI tracking with gain. In a load frequency control system, AWPI tracking is applied for its less overshoot and faster settling time.

Feedback is the difference in output from before and after saturation. Feedback gain is referred to as [19].

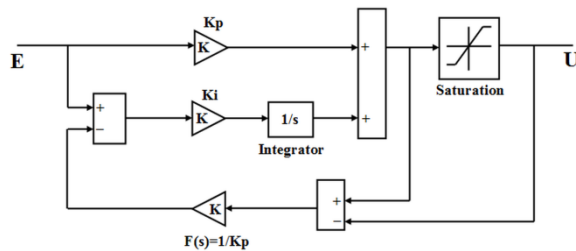

Fig.3. Anti-Wind up PI controller

$$F(s) = \frac{1}{K_p} \quad (6)$$

Anti-windup PI controller with the effect of saturation improves the system performance by allowing it to operate in the linear region most of the time and recover quickly from nonlinearity. It reduces frequency oscillation as well as settling time.

#### 5. Fuzzy Gain Scheduling Controller for LFC

The unchanging gains of PI controller for change in an input error produce an abrupt change in frequency. Soft computing tuning of  $K_p$  and  $K_i$  in a PI controller can defeat this issue. In this analysis, Fuzzy Gain Scheduling controller is proposed for auto tuning of gains [20]. Fuzzy logic controllers (FLCs) are

suitable for nonlinear system and system with vague data [21, 22]. Their advantages are a non requirement of a mathematical model, robustness, and acceptance of nonlinearity. In this analysis, ACE is fed as input to the FGS controller in an interconnected multi area thermal power system.

In this controller gains of PI controller such as  $K_p$  and  $K_i$  are tuned using the Fuzzy logic module. The Fuzzy inference of fuzzy Gain Scheduling controller is based on the fuzzy associative matrices. The calculation speed of the controller is very quick, which can satisfy the rapid need of the controlled object. The block diagram of the FGS system is shown in Figure 4.

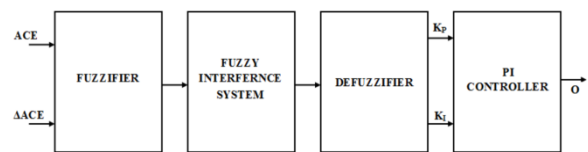

Fig.4. Block diagram of the Fuzzy gain scheduling controller

The design algorithm of Fuzzy gain scheduling controller in this paper is to tune the  $k_p$  and  $k_i$  values via fuzzy inference based on the current  $e$  and  $ec$  to make the control object attain the better transient performance.

Area control error “ $e$ ” and error change rate “ $ec$ ” are used as fuzzy input and the proportional gain  $k_p$  the integral gain  $k_i$  are used as fuzzy outputs. The outputs of the fuzzy controller are given to the PI controller which determines the turbine speed. The membership functions of input variables  $E$  and  $EC$  are five defined as {NB, NS, ZO, PS, PB}, where PB, PS, ZO, NS, and NB represent Positive Big, Positive Small, Zero, Negative Small and Negative Big respectively. The output variable of  $k_p$  and  $k_i$  are configured with four membership functions such as Zero, Positive Small, positive medium, and Positive Big. Triangular distribution functions are used for all variables. The membership function for all variables is shown in Figure 5 and 6.

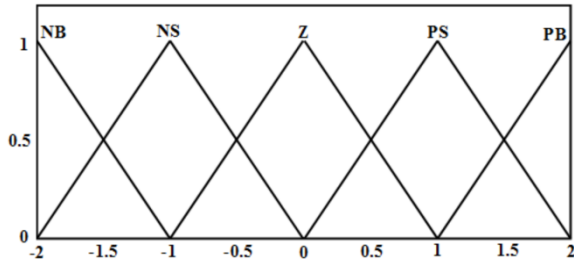

Fig.5. Membership functions of inputs

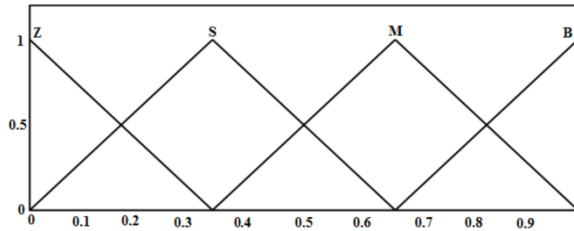

Fig.6. Membership functions of KP

The fuzzy rules are framed in order to make the system output response static and dynamic performances optimal. The fuzzy rules for  $K_p$  and  $K_i$  are given in table 1 and table 2. The Mamdani inference method is used as the fuzzy inference mode. The inference can be written as

"IF E is NS AND EC is PS THEN KP is PS, KI is PB."  $K_p$  and  $K_i$  are written the same as 25 fuzzy condition statements. The MIN-MAX method of fuzzification and centroid method of defuzzification is adopted.

Table 1 Control Rules for  $K_p$

Ec \ e	NB	NS	ZO	PS	PB
NB	Z	Z	Z	Z	Z
NS	PM	PM	PM	PM	PM
ZO	PB	PB	Z	PB	PB
PS	PS	PM	PM	PM	PM
PB	Z	PS	PB	PB	PB

Table 2 Control Rules for  $K_i$

ec \ e	NB	NS	ZO	PS	PB
NB	PB	PB	PB	PB	PM
NS	PM	PB	PS	PS	PS
ZO	PM	PB	Z	PS	PB
PS	PS	PS	PS	PS	PS
PB	PM	PB	PB	PM	PB

The Fuzzy Gain Scheduling controller lessens the magnitude of fluctuations in frequency error.

## 6. Results and analysis

Three area thermal-thermal-thermal interconnected power system simulation has been analyzed using MATLAB. Initially, the system is analyzed using the traditional PI controller. Then the same LFC system is analyzed using an anti-windup PI controller and Fuzzy Gain Scheduling controller in the aspects of settling time and overshoot. To analyze the performance of the plant, in this paper all thermal systems are disturbed by 1% step load. Table 1 shows the parameters of the system considered.

Table 3 Power Plant Parameters

R1, R2	2Hz/p.u.M.W
$T_T$	0.3 Sec
$T_H$	0.08 Sec
$K_p$	100
$T_p$	20 Sec
$A_{12}$	-1
T	0.0707
B	0.425 p.u.M.W / Hz

Figure 7-10 shows the  $\Delta f$  in system1-3 and Tie line of the three areas using PI control.

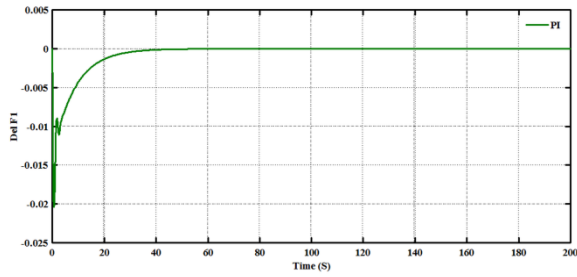

Fig.7. Frequency deviations in system 1 using PI

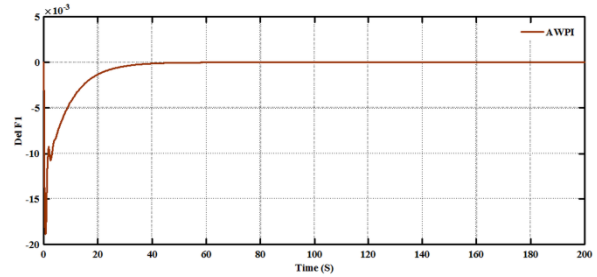

Fig.11. Frequency deviation in system1 using AWPI

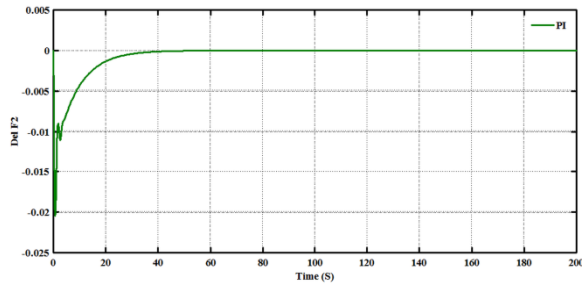

Fig.8. Frequency deviation in system 2 using PI

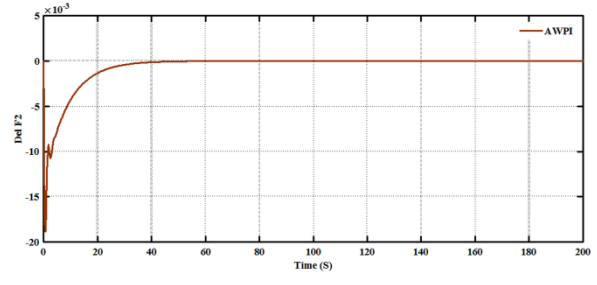

Fig.12. Frequency deviation in system 2 using AWPI

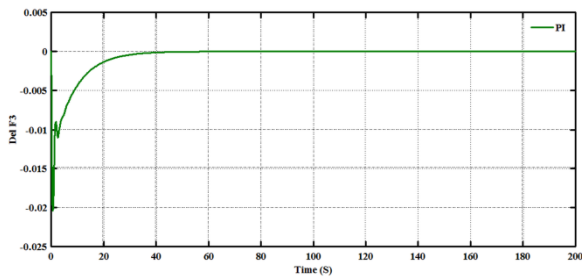

Fig.9. Frequency deviation in system 3 using PI

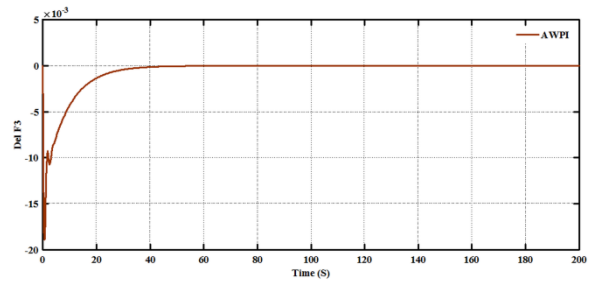

Fig.13. Frequency deviation in system 3 using AWPI

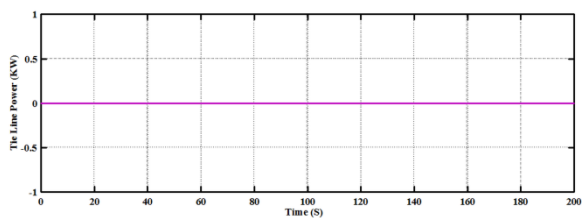

Fig.10. Power deviation in tie lines using PI

From the figure 7-9 it is noted that  $\Delta f$  reaches zero after settling time, but the oscillation in frequency at the time of starting of perturbation is high. Figure 11-13 shows the frequency deviation in system1- 3 using Anti-windup PI control.

From the figures 11-13 it is noted that oscillation in  $\Delta f$  at the time of starting is reduced compared to PI. Figure 14-16 shows the  $\Delta f$  of the three areas using fuzzy gain scheduling controller.

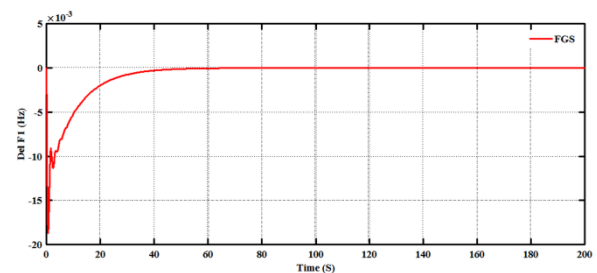

Fig.14. Frequency deviation in system 1 using Fuzzy Gain Scheduling controller

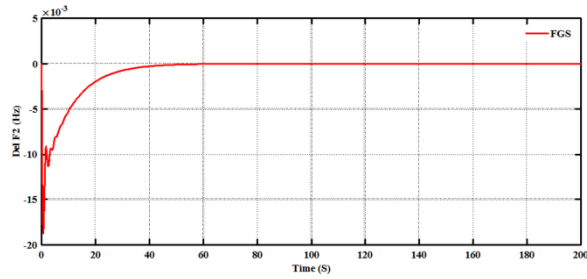

Fig.15. Frequency deviation in system 2 using Fuzzy Gain Scheduling controller

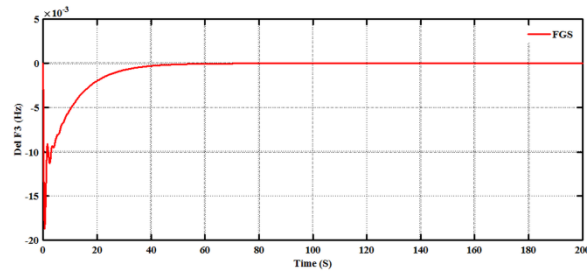

Fig.16. Frequency deviation in system 3 using Fuzzy Gain Scheduling controller

Comparison of frequency deviation of three controllers in system 1-3 is shown in Figure 17.

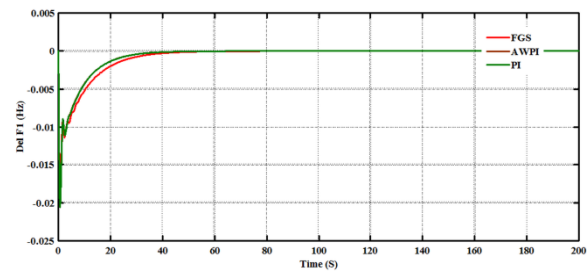

Fig.17. Comparison of frequency deviation in system 1 using PI, AWPI and Fuzzy Gain Scheduling controller

From the figures 14-17 it is obvious that FGS reduces overshoot compare to all other controllers discussed. Table 4 depicts performance comparisons of PI, AWPI and FGS controllers.

Table 4 Comparison of controller performance in  $\Delta f$

Controller	Overshoot (Hz)	Settling Time (Sec)
PI	0.0206	55
AWPI	0.0192	55
Fuzzy Gain Scheduling controller	0.0187	50

From table 4 it is observed that FGS produces better performance in the aspect of reduction in overshoot and settling time compare to PI and AWPI controllers.

## 7. Conclusion

In this study load frequency control on three area thermal- thermal- thermal interconnected system is analyzed. Initially, the system is analyzed using a PI controller designed using Zeigler Nicholas' method. By observing these results, the PI controller reduces steady state error. But it has overshoot and long settling time. To enhance the performance of system Anti-windup PI controller is applied to the system. It is an integral windup method of control, and it reduces overshoot compare to PI controller. Then the Fuzzy Gain Scheduling controller is implied to improve the performance of the system. It is an online tuning of controller gains and delivers reduced overshoot and reduced settling time compare to other controllers. All controllers are analyzed with the same load disturbance. From all above results, it is obvious that Fuzzy Gain Scheduling controller has better performance than other two controllers in frequency deviations and tie line power deviations.

## References:

- [1] Nanda,J, A.Mangala and S. Suri, "Some new findings on automatic generation control of an interconnected hydrothermal system with conventional controllers," *IEEE transaction of Energy Conversion*, vol.21, No.1, pp. 187-194, 2006. DOI: [10.1109/TEC.2005.853757](https://doi.org/10.1109/TEC.2005.853757)
- [2] Zribi M, Al-Rashed M, and Alrifai M, "Adaptive decentralized load frequency control of multi area power systems," *Int Journal of Electric Power Energy System*, vol.27, No.8, pp.575-83, 2005. DOI: [10.1016/j.ijepes.2005.08.013](https://doi.org/10.1016/j.ijepes.2005.08.013)
- [3] Kumari K,-S., Shankar G., and Gupta S, "Load frequency control using ANN-PID controller," *In Power Electronics, Intelligent Control and Energy Systems (ICPEICES)*, IEEE International Conference, pp. 1-6, July 2016.
- [4] Gholamrezaie V, Dozein, M,-G, Monsef H, and Wu, B. (2017). "An Optimal Frequency Control Method through a Dynamic Load Frequency Control (LFC) Model Incorporating Wind Farm," *IEEE Systems Journal*, Mar 2017. DOI: [10.1109/JSYST.2016.2563979](https://doi.org/10.1109/JSYST.2016.2563979)

- [5] Mangla A and Nanda J, "Automatic Generation Control of an Interconnected Hydro- Thermal System Using Conventional Integral and Fuzzy logic Control," In Proc. IEEE Electric Utility Deregulation, Restructuring and Power Technologies, DRPT2004, Hong Kong, vol.1, pp. 372-377. Oct 2004.
- [6] Wang, Kang, et al., "Control of tie-line power flow by nonlinear SMES controller," In Power and Energy Society General Meeting- Conversion and Delivery of Electrical Energy in the 21st Century, pp. 1-5. IEEE, 2008.
- [7] Tariq, Mohd, et al., "Fast response Anti-windup PI speed controller of Brushless DC motor drive: Modeling, simulation and implementation on DSP," *Journal of Electrical Systems and Information Technology* Vol.3, No.1, pp. 1-13, 2016. DOI: [10.1016/j.jesit.2015.11.008](https://doi.org/10.1016/j.jesit.2015.11.008)
- [8] Shin, Hwi-Beon, "New antiwindup PI controller for variable-speed motor drives," *IEEE Transactions on industrial electronics*, Vol.45, No.3, pp. 445-450, Jun 1998. DOI: [10.1109/41.679002](https://doi.org/10.1109/41.679002)
- [9] Xin-lan Li, Jong-Gyu Park and Hwi-Beom Shin, "Comparison and Evaluation of Anti-Windup PI Controllers," *Journal of power Electronics*, Vol.11, No.1, pp. 45-50, 2010. DOI: 10.6113/JPE.2011.11.1.045
- [10] Wahyudi, Tarig Faisal and Abdulgani Albagul, "Anti-Windup Scheme for Practical Control of Positioning Systems," *IIUM Engineering Journal*, Vol.5, No.2, pp.1-15, 2004.
- [11] Hiyama, T., S. Koga, and Y. Yoshimuta. "Fuzzy logic based multi-functional load frequency control." *Power Engineering Society Winter Meeting, 2000. IEEE*. Vol. 2. IEEE, pp. 921-926, 2000. DOI: [10.1109/PESW.2000.850052](https://doi.org/10.1109/PESW.2000.850052)
- [12] Çam E, Kocaarslan I, "Fuzzy logic controller in interconnected electrical power systems for load-frequency control," *Int Journal of Electric Power Energy System*, Vol.27, No.8, pp. 542-9. 2005. DOI: [10.1016/j.ijepes.2005.06.003](https://doi.org/10.1016/j.ijepes.2005.06.003)
- [13] Zhen-Yu Zhao, Masayoshi Tomizuka and Satoru Isaka, "Fuzzy gain scheduling of PID controllers," *IEEE transactions on systems Man and Cybernetics*, Vol.23, No.5, pp. 1392-1398. 1993. DOI: [10.1109/21.260670](https://doi.org/10.1109/21.260670)
- [14] Mieczysław A. Brdy'S, Jonathan J. Littler, "Fuzzy Logic Gain Scheduling For Non-Linear Servo Tracking," *Int. Journal of Applied Math. Computer Science*, Vol.12, No.2, pp. 209-219, 2002.
- [15] Blanchett T.-P, Kember G.-C, and Dubay R, "PID gain scheduling using fuzzy logic," *ISA Transactions*, Vol.39, pp. 317-325, 2000. DOI: [10.1016/S0019-0578\(00\)00024-0](https://doi.org/10.1016/S0019-0578(00)00024-0)
- [16] Ghafari, A.S. and Alasty, A., 2004, June. Design and real-time experimental implementation of gain scheduling PID fuzzy controller for hybrid stepper motor in micro-step operation. In *Mechatronics, 2004. ICM'04. Proceedings of the IEEE International Conference on* (pp. 421-426). IEEE.
- [17] Piltan, Farzin, Alireza Salehi, and Nasri Sulaiman, "Design artificial robust control of second order system based on adaptive fuzzy gain scheduling," *World Applied Sciences Journal*, Vol.13, No.5, pp. 1085-1092, 2011.
- [18] N. Cohn, "Some aspects of tie-line bias control on interconnected power systems," *American Institute Electrical Engineering Transaction*, Vol.75, pp. 1415-1436, Feb 1957. DOI: [10.1109/AIEEPAS.1956.4499454](https://doi.org/10.1109/AIEEPAS.1956.4499454)
- [19] Anirban Ghoshal and Vinod John, "Anti-windup Schemes for Proportional integral and Proportional Resonant Controller," *National Power Electronic Conference*, pp.1-6, 2010.
- [20] Chaiyatham, Theerawut, and Issarachai Ngamroo, "Optimal fuzzy gain scheduling of PID controller of superconducting magnetic energy storage for power system stabilization," *International journal of innovative computing, information and control*, Vol.9, No. 2, pp. 651-666, 2013.
- [21] C. Indulkar, B. Raj, "Application of fuzzy controller to automatic generation control," *Electric Machines and Power Systems*, Vol.23, No.2, pp. 209-220, 1995. DOI: [10.1080/07313569508955618](https://doi.org/10.1080/07313569508955618)
- [22] Soundarrajan, A, and S Sumathi, "Effect of Non-linearities in fuzzy based load frequency

control,” *International Journal of Electronic Engineering Research*, Vol.1, No.1, pp. 37-51, 2009.