

PERFORMANCE COMPARISON OF DIFFERENT BIDIRECTIONAL DC – DC CONVERTERS FOR SOLAR PV SYSTEM

GOMATHILS

Assistant Professor,
St. Joseph's Institute of Technology,
Chennai, India.
sgomathi411@gmail.com

RAGHAVENDIRAN T.A

Principal
Anand Institute of Higher Technology,
Chennai, India.

SUGANYADEVI M.V

Associate Professor
Saranathan College of Engineering
Trichy, India.

DEEPAK ARUMUGAM

Associate Professor,
St Joseph's Institute of Technology,
Chennai, India.

Abstract: In this paper the different topologies of Bidirectional DC-DC Converter(BDC) in buck-boost mode of operation for solar PV system are presented. The different topologies of non-isolated BDC are high gain, multiple input, series capacitor, switched capacitor & inductor. The open loop simulation of the four topologies is carried out to find output voltage and ripples for both step-up and step-down modes. The measurements of voltage gain and ripple factor give the best topology for solar PV system. Finally, the closed loop simulation and hardware testing of the best topology which has high voltage gain and low ripples are presented for both step-up and step-down mode operations.

Keywords: PV system, bidirectional DC-DC converter, non-isolated, buck-boost mode, high voltage gain.

1. Introduction:

In the current 21st century, development of sustainable energy plays an important in meeting the energy demand in the market and problems associated with fossil fuels, coal, oil, etc. Non-conventional energy sources such as solar, wind, tidal, geo-thermal, etc., act as alternative source and provide solution for global warming, greenhouse effect gases and environmental degradation [1-5]. Across the globe non-conventional energy sources have produced 24.5% of total energy production till 2016 [6]. Of these solar energy source is more familiar due its advantages such as wide availability, high energy density, reliability, scalable and economic feasibility. It is suitable for both grid connected system and standalone application [7]. Due to its intermittent nature solar PV system requires power electronics circuits and energy storage devices to make the output constant and to get reliable operation.

DC-DC converters involve the power conversion stage of the PV system for supplying power to the energy storage element. But these converters have the drawback of unidirectional power flow capability. These converters can be converted into bidirectional converters by replacing

diodes into controllable switches in the existing circuit. PV system along with bidirectional converter and energy storage elements is suitable for hybrid vehicle, spacecraft power systems and UPS. It has the advantages of low cost, high efficiency and better performance than ordinary DC-DC converter [8]. The different types of DC-DC converters and their control techniques used in the solar PV system and their efficiency. Bidirectional converter is classified into isolated and non-isolated converter. Low cost, transformer less, better efficiency, small size and no isolation required between source and load are the major advantages of non-isolated converters. But they have the drawback of low voltage regulation. On the other hand, isolated converters have the advantage of high voltage regulation along with transformer. The different topologies and the advantages & disadvantages of the non-isolated converter. The non-isolated BDC for renewable energy system and battery storage system with buck-boost mode operation, modeling, simulation analysis and hardware testing are briefly given in [7-8]. None of the above works found in the literature discusses the non-isolated BDC for solar PV system in terms of ripple factor and voltage gain. In this paper, the comparison of voltage gain and ripple factor of four different topologies in non-isolated bidirectional BDC including high gain, multiple input, series capacitor, switched capacitor and inductor for solar PV system is presented. The organization of the paper is as follows: Second section deals with the description and modeling of the different topologies in bidirectional DC-DC converter. The simulation analyses of the converter with different topologies are presented in section 3. The hardware validation of the converter is presented in section 4. The work is concluded in section 5.

2. Different Topologies in Bidirectional DC – DC converter:

The different Converter topologies of bidirectional BDC for PV system are given in this section. The different Non-Isolated converters are used to design High gain and

High energy conversion. These BDC are operated in both Step-up and step-down modes. In the step-up mode energy is stored in the battery and while in the step-down mode energy stored in the battery is used for PV applications. Renewable energy sources are important to meet power demands. Scarcity of power is balanced by using renewable energy sources.

First Topology High Gain DC-DC Converter (HGBDC) gives high voltage gain and high power used for solar applications. It has two switches and four diodes. Less number of switches decreases the switching stresses. Second topology is Multiple Input Bidirectional DC-DC Converter (MIBDC) that is used to connect the multiple sources with different voltage levels. It increases or decreases the voltage level with bidirectional power flow capability. It transfers the power between any two sources with different voltage levels. Two sources used in battery 1 and battery 2 are in different voltage levels. So power flows in two directions, from sources to the load and from the load to sources. It operates in five modes. Third topology is series capacitors connected Non-Isolated switched capacitor Bidirectional Dc-Dc Converter (SCBDC). It has four switches. These switches are operated in both Boost/Buck modes. Two series capacitors are connected in high voltage side. Fourth topology is switched capacitor-Inductor based Bidirectional Dc-Dc Converter (SCIBDC) having has five switches and four reactive elements (two capacitors and two inductors). All the four bidirectional converter topologies are shown in figure 1.

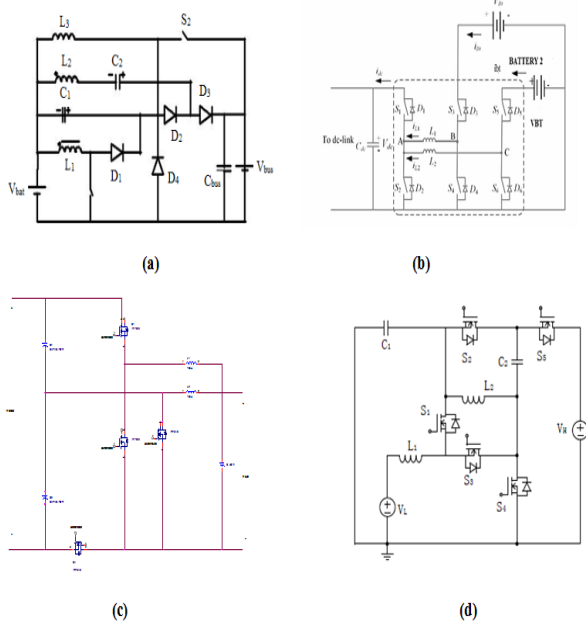

Fig. 1. Circuit Diagram of Different Topologies

The design of the four topologies is given in the following equations. The design equations of High gain Bidirectional DC-DC Converter are given in the following equations:

For Step-up mode

$$\text{Inductor voltage } V_{L1} = V_{\text{bat}} \quad (1)$$

$$\text{Capacitor voltage } V_{C2} = V_{L2} + V_{C1} \quad (2)$$

$$\text{Bus voltage } V_{\text{bus}} = V_{L2} + V_{C2} + V_{\text{bat}} \quad (3)$$

$$\text{Voltage ratio } \frac{V_{\text{bus}}}{V_{\text{bat}}} = \frac{n+1}{1-\Delta} \quad (4)$$

For Step-down mode

$$\text{Bus voltage } V_{\text{bus}} = V_{L3} + V_{\text{bat}} \quad (5)$$

$$\text{Battery voltage } V_{\text{bat}} = V_{L3} \quad (6)$$

$$\text{Voltage ratio } \frac{V_{\text{bat}}}{V_{\text{bus}}} = \Delta \quad (7)$$

The design equations of Series capacitors connected BDC is given in the following equations:

$$\text{Capacitor voltage } V_{C1} = V_{C2} = \frac{1}{1-\delta_{\text{SU}}} V_{\text{Low}} \quad (8)$$

$$\text{Output voltage } V_{\text{high}} = V_{C1} + V_{C2} \quad (9)$$

$$\text{Voltage ratio } V_{\text{CR SU}} = \frac{V_{\text{high}}}{V_{\text{Low}}} = \frac{2}{1-\delta_{\text{SU}}} \quad (10)$$

For Step-down mode

$$\text{Capacitor voltage } V_{C1} = V_{C2} = 0.5 V_{\text{High}} \quad (11)$$

$$\text{Voltage ratio } V_{\text{CR SD}} = \frac{V_{\text{Low}}}{V_{\text{High}}} = \frac{\delta_{\text{SD}}}{2} \quad (12)$$

$$\text{Ripple factor} = \frac{\Delta V_{\text{max}}}{V_{\text{max}}} \quad (13)$$

$$\text{Voltage gain } A = \frac{V_{\text{out}}}{V_{\text{in}}} \quad (14)$$

The design equations of the Switched capacitor-Inductor connected BDC are given in the following equations:

For Step-up mode ($0 < t < \delta$)

$$L_1 \text{ charged by line voltage } V_L = V_{L1} \quad (15)$$

$$L_2 \text{ charged by capacitor } C_1 V_{L2} = V_{C1} \quad (16)$$

$$C_2 \text{ charged by capacitor } C_1 V_{C2} = V_{C1} \quad (17)$$

Stage 2: switches S_1 and S_5 are turned on ($\delta < t < T$)

$$L_1, L_2, \text{ and } C_2 \text{ are discharged and Capacitor } C_1, \text{ charged} \quad (18)$$

$$V_L - V_{L1} - V_{L2} + V_{C2} = V_H \quad (18)$$

$$V_L - V_{L1} = V_{C1} \quad (19)$$

Two inductor voltages

$$\delta V_L + (1-D)T (V_L + V_{C2} - V_{L2} - V_H) = 0 \quad (20)$$

$$\delta V_{C1} + (1-D)T (V_L + V_{C2} - V_{L1} - V_H) = 0 \quad (21)$$

$$V_{C1} = V_{C2} = V_L / (1-D) \quad (22)$$

For Step-down mode

Stage 1: S_1 and S_5 are turned on

$$V_L + V_{L1} = V_{C1} \quad (23)$$

$$V_L + V_{L1} + V_{L2} + V_{C2} = V_H \quad (24)$$

Stage 2: S_2, S_3 and S_4 turned on

$$L_2 \text{ discharges capacitor } C_1 \text{ and } C_2 \text{ discharges capacitor } C_1 \quad (25)$$

$$V_L = V_{L1} \quad (25)$$

$$V_{L2} = V_{C2} \quad (26)$$

$$V_{C2} = V_{C1} \quad (27)$$

$$\delta (V_{C1} - V_L) + (1-D)T (-V_L) = 0 \quad (28)$$

Based on the above expressions the design of converters is carried out.

3. Simulation Analysis

The simulation analysis of the different bidirectional converter topologies is presented in this chapter. The simulation analysis of the converter was carried

out using MATLAB software. In all the 4 topologies input voltage 18V was applied to the converter and the operating frequency of all the switches was 20KHZ. In all the 4 topologies voltage was measured in step-up mode operation and the gain value was also calculated. The simulation model of 4 different topologies is shown in figure 2. All topologies were simulated by open loop mode of operation.

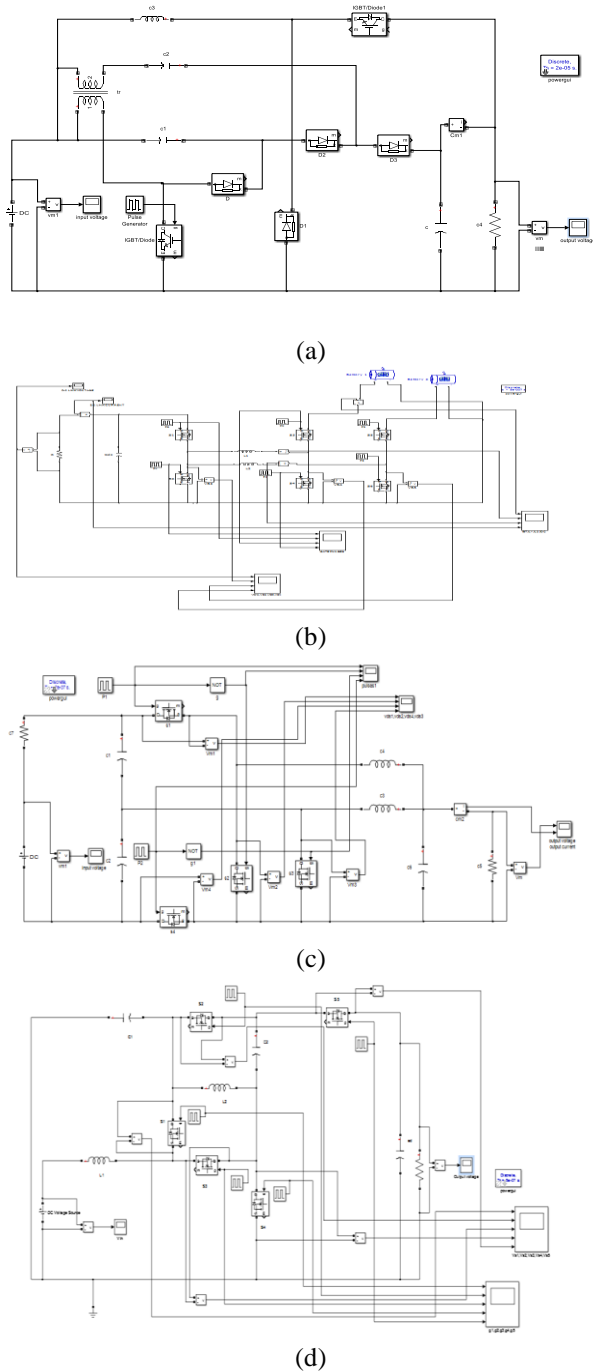

Fig.2. Simulation model of different Bidirectional DC-DC Converter, (a) High gain Bidirectional DC-DC Converter, (b) Multiple Input Bidirectional DC-DC Converter, (c) Series capacitors connected Bidirectional DC-DC Converter, (d) Switched Capacitor- Inductor connected Bidirectional DC-DC Converter

The input voltage applied to all the four converters was 18V which is shown in figure 3. The output voltage obtained from the simulation is shown in figure 4 and its comparison given in figure 5. From this, it becomes obvious that the highest output voltage is produced in the MIBDC topology and this value is equal to 360V. Also out of the 4 topologies the voltage gain of the MIBDC is 20. These are shown in figure 6. Finally, the ripple factor of the 4 converter is given in figure 7. From this, it can be seen that the ripple factor HGBDC is low compared with the other topologies and this value is equal to 0.0257. The comparison of output voltage and ripple factor is given in Table 1 and Table 2.

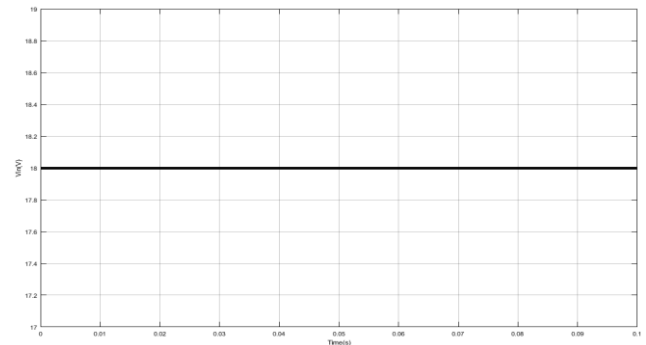
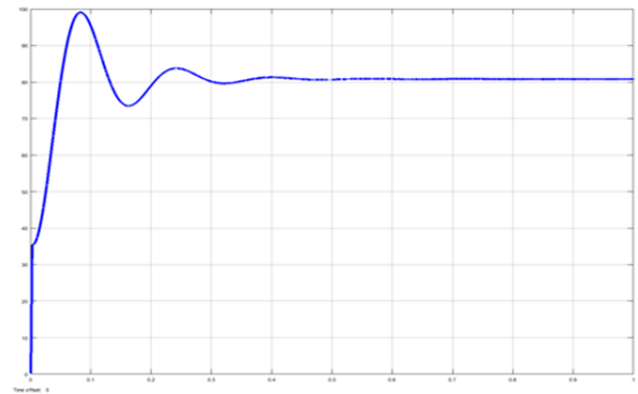
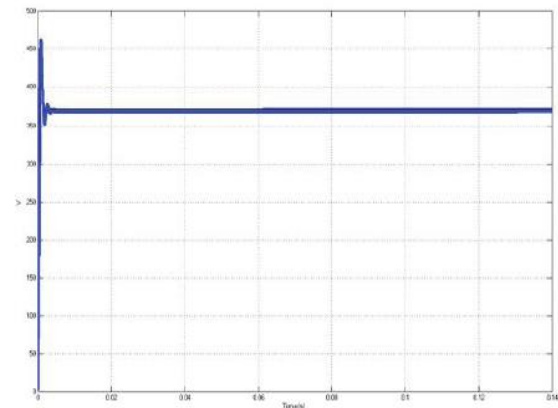

Fig.3. Input Voltage for step-up mode of operation



(a)



(b)

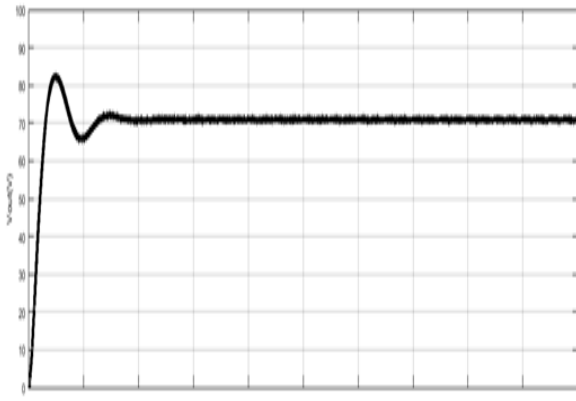

(c)

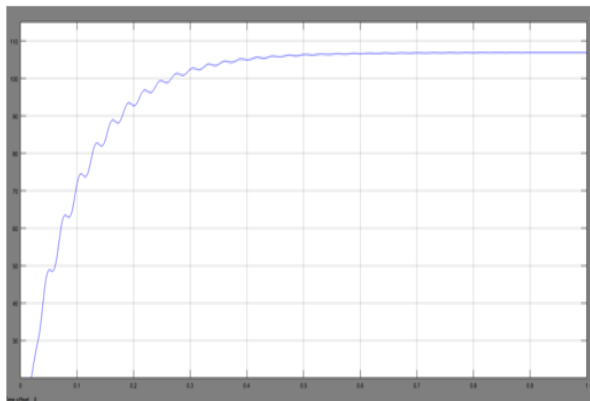

(d)

Fig. 4. Output voltage waveforms of (a) HGBDC, (b) MIBDC, (c) SCBDC, (d) SCIBDC in step-up Mode

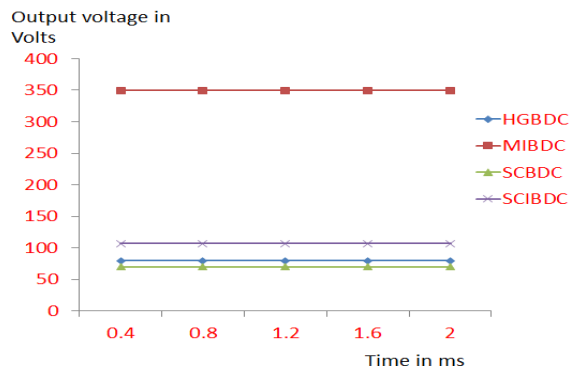

Fig. 5. Output voltage for different Bidirectional DC-DC Converter topologies

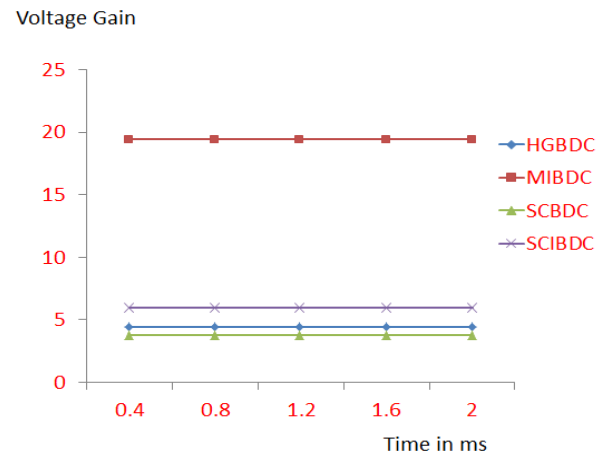

Fig. 6. Voltage gain at different Bidirectional DC-DC Converter topologies

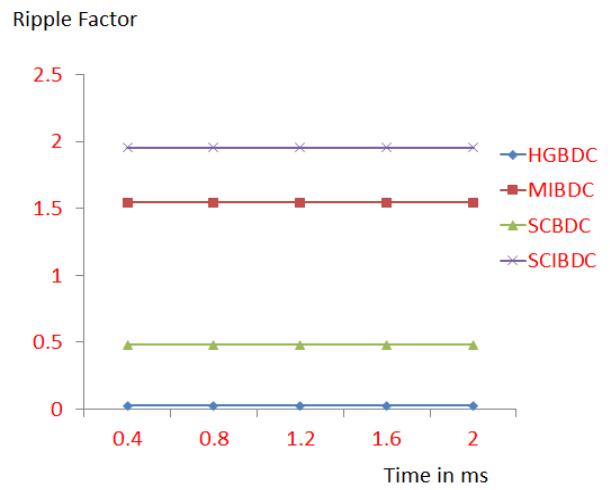

Fig. 7. Ripple factor for different Bidirectional DC-DC Converter topologies

Table.1.Comparison of output voltage and ripple factor for 4 topologies

S.No	Topology	Input Voltage	Output Voltage	Voltage Gain
1	High Gain Bidirectional Dc-Dc Converter Standalone Systems	18	80	4.44
2	Multi Input Bidirectional Dc-Dc Converter	18	350	19.44
3	Series capacitors connected Bidirectional Dc-Dc Converter With High Step-Down And Step-Up Voltage Conversion Ratio	18	70	3.8
4	Switched capacitor –inductor based Bidirectional Dc-Dc Converter	18	107	5.94

Table.2. Comparison of ripple factor for all 4 topologies

S.No	Topic	Switching Frequency	Ripple Factor	Parameters
1	High Gain Bidirectional Dc-Dc Converter Standalone Systems	20kHz	0.02597	$L_3= 1e-3H$ $C_1= 10e-6F$ $C_2= 10e-6F$ $C_{bus}= 1000e-6F$ $C_1=3\mu F$
2	Multi Input Bidirectional Dc-Dc Converter	20 kHz	1.5432	$C_2=3\mu F$ $L_1=100\text{ mh}$ $L_2=100\text{ mh}$
3	Switched capacitor – inductor based Bidirectional Dc-Dc Converter	20kHz	0.356	$C_1= 1000e-6F$ $L_1= 130e-6H$ $L_2= 130e-6H$
4	Bidirectional Dc-Dc Converter With High Step-Down And Step-Up Voltage Conversion Ratio(2016)	20kHz	1.95530	$C_1= 1000e-6F$ $C_2= 1000e-6F$ $L_1= 130e-6H$ $L_2= 130e-6H$

4. Hardware Implementation:

Hardware implementation of the multi input DC-DC converter is shown in figure 8. The proposed Multiple Input BDC is to interface more than two sources of power operating at different voltage levels. It gives the highest output voltage in the absence of any one of the sources. Two batteries are used to give input voltage. Hardware model consists of Power circuit, Control circuit and Isolation circuit. Power circuit consists of two batteries having the voltages of 6V and 12V, BDC and load. Converter circuit has 6 MOSFET switches. Similarly, the control circuit has microcontroller and buffer circuit. The function of PIC16F877A controller circuit is to give gate pulses for MOSFET switches. Buffer circuit is used as an amplifier in this system and the current from the micro controller is amplified and fed into isolation circuit. The input voltage applied to the converter is 18V which is shown in figure 9. The output voltage of the MIBDC is 360 V and it is shown in figure 10.

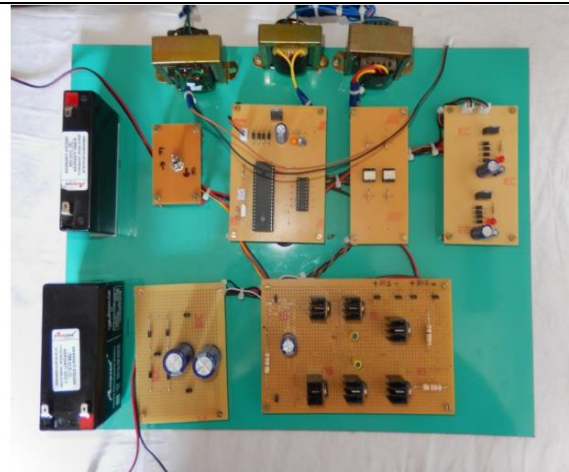

Fig. 8.Hardware implementation of Multiple Input Bidirectional Dc-Dc Converter

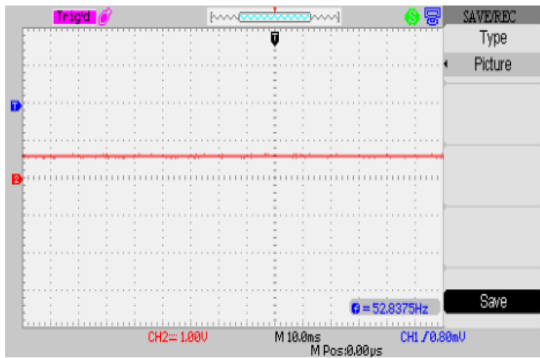

Fig.9 . Input voltage from different sources

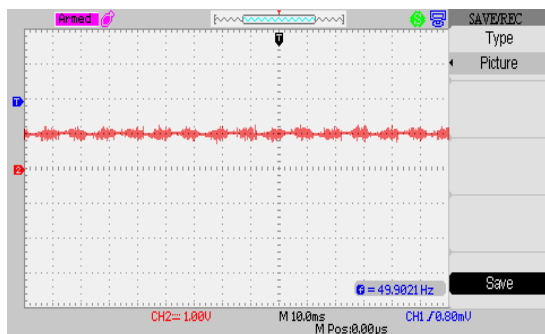

Fig.10 . Output Voltage of Multiple Input Bidirectional DC-DC Converter

5. Conclusion

The different topologies of non-isolated BDC were presented for solar PV system. From the open loop simulation of the four different topologies, it was found that the multi input BDC had high voltage gain compared with series capacitor and switched capacitor and inductor topologies. The hardware implementation of the multi input BDC was tested and the output voltages for both step-up and step-down modes were presented. Hardware and simulation results closely matched. It was concluded that this topology would be suitable for hybrid vehicles and standalone PV system.

The ripples produced in the MIBDC can be reduced by providing non-linear controller such as fuzzy controller or neural controller with closed loop operation. The high power rating of the converter can be achieved by cascade operation of the MIBDC.

References

- [1] Li Tianze, Lu Hengwei, Jiang Chuan, Hou Luan, and Zhang Xia, "Application and design of solar photovoltaic system" Journal of Physics: Conference Series 276 (2011) 012175.
- [2] Amresh Kumar Singh , Ikhlagh Hussain , and Bhim Singh , " Double-Stage Three-Phase Grid-Integrated Solar PV System With Fast Zero Attracting Normalized Least Mean Fourth Based Adaptive Control" IEEE Transactions On Industrial Electronics, Vol. 65, No. 5, May 2018.
- [3] Maithili.P and Sharmitha.D, "Three Port DC-DC Converter For Standalone Photovoltaic System", International Journal of Pure and Applied Mathematics, Vol. 117, No. 8, 2017, pp- 67-71.
- [4] Sasikumar.S and Krishnamoorthy .K, "A literature Survey on Bidirectional DC-DC Converter" IJLTEMAS, Volume No 4, Issue 10, October 2015.
- [5] Geetha D.K and Pramila P, "A survey on Efficiency in PV Systems with DC-DC converter" Communications of applied Electronics, ISSN 2394-4714.
- [6] Wai, R.,J. Duan, R,Y, Jheng, K,H "High-efficiency bidirectional DC-DC converter with high-voltage gain", Power Electronics, IET , vol.5,no.2, pp.173-184, Feb. 2012.
- [7] Duan, R.,Y.and Lee, J.D, "High-efficiency bidirectional DC-DC converter with coupled inductor", Power Electronics, IET , vol.5, no.1, pp.115-123, January 2012 .
- [8] Li Xin and XiePu, " Research on control strategy for Battery system of Photovoltaic Power system based on Bidirectional DC-DC converter", 5th International Conference on Environment, materials, chemistry and power Electronics 2016 pp .424-427.