

# **RESEARCH ON IMPACT OF THE EU CLIMATE-ENERGY PACKAGE ON ROMANIAN INDUSTRIAL ACTIVITIES**

Teză destinată obținerii  
titlului științific de doctor  
la

Universitatea "Politehnica" din Timișoara  
în domeniul inginerie mecanică  
de către

**ec. Dorel Cicirone BĂDESCU**

Conducători științifici: Prof.dr.ing. habil Ioana IONEL  
Prof.dr.ing. habil Winfried RUSS

Referenți științifici: Prof.dr.ing. George DARIE  
Prof.dr.ing. Ioan Dan GHEORGHIU  
Prof.dr.ing. Mihai JĂDĂNEANȚ

Ziua susținerii tezei: 12.11.2010

Seriile Teze de doctorat ale UPT sunt:

- |                        |   |
|------------------------|---|
| 1. Automatică          | 7. Inginerie Electronică și Telecomunicații |
| 2. Chimie              | 8. Inginerie Industrială                    |
| 3. Energetică          | 9. Inginerie Mecanică                       |
| 4. Ingineria Chimică   | 10. Știința Calculatoarelor                 |
| 5. Inginerie Civilă    | 11. Știința și Ingineria Materialelor       |
| 6. Inginerie Electrică |   |

Universitatea „Politehnica” din Timișoara a inițiat seriile de mai sus în scopul diseminării expertizei, cunoștințelor și rezultatelor cercetărilor întreprinse în cadrul școlii doctorale a universității. Seriile conțin, potrivit H.B.Ex.S Nr. 14 / 14.07.2006, tezele de doctorat susținute în universitate începând cu 1 octombrie 2006.

Copyright © Editura Politehnica – Timișoara, 2010

Această publicație este supusă prevederilor legii dreptului de autor. Multiplicarea acestei publicații, în mod integral sau în parte, traducerea, tipărirea, reutilizarea ilustrațiilor, expunerea, radiodifuzarea, reproducerea pe microfilme sau în orice altă formă este permisă numai cu respectarea prevederilor Legii române a dreptului de autor în vigoare și permisiunea pentru utilizare obținută în scris din partea Universității „Politehnica” din Timișoara. Toate încălcările acestor drepturi vor fi penalizate potrivit Legii române a drepturilor de autor.

România, 300159 Timișoara, Bd. Republicii 9,  
tel. 0256 403823, fax. 0256 403221  
e-mail: editura@edipol.upt.ro

## Acknowledgements

The present study was carried out at the "Politehnica" University of Timisoara, Faculty of Mechanical Engineering, Department of Mechanical Machines, Equipments and Transportation.

First of all, I would sincerely like to thank both my scientific supervisors Prof.dr.eng. habil Ioana Ionel from the "Politehnica" University of Timisoara and Prof.dr.eng. habil Winfried Russ from the Technical University of Munich, for their excellent guidance and scientific support. Their wide experience and knowledge in various research fields, especially energy and environmental protection, have been very useful for my development and research, including the finalization of this thesis.

The high academic level of the "Politehnica" University of Timisoara has "pushed" and "forced" me to work hard during my PhD study enabling and supporting me to raise to the level of this high ranked institution.

I also want to thank the specialists from the Institute for Studies and Power Engineering, in particular Prof.dr.eng. Ioan Dan Gheorghiu, General Director of ISPE Bucharest, and Mrs. Carmencita Constantin, Director of the Energy and Environment Division, for their cooperation, mentioning that with their help I succeeded to understand and find the applicability of my research and steps to follow.

Warm thanks are addressed to all the scientific reviewers of the thesis and to the Dean office of the Faculty of Mechanical Engineering.

Thanks also to dr.eng. Aurel Matei, General Director of COLTERM Timisoara, for both logistical and professional support.

I was very honored and even lucky to have the help of many people from different institutions, who contributed to this study and, sincerely, I want to apologize that I did not mention them.

For me this thesis was a struggle with myself, as time and novelty were both together important.

I thank also my family from home and office.

Timisoara, 12 November 2010

Dorel Cicirone BĂDESCU

Dedic această lucrare

Familiei mele

Bădescu, Dorel Cicirone

**Research on impact of the EU climate-energy package on Romanian industrial activities**

Teze de doctorat ale UPT, Seria 9, Nr. 86, Editura Politehnica, 2010, 197 pagini, 111 figuri, 30 tabele.

ISSN: 1842-4937

ISBN: 978-606-554-207-5

Cuvinte cheie:

Greenhouse Gas Emissions, European Union Emissions Trading Scheme, EU Climate-Energy Package, Emission Allowances, Industrial Activities, Impact of EU ETS, Production Costs, CO<sub>2</sub> Capture, Carbon Capture and Storage.

Rezumat,

The present study is aimed at initiating a unitary procedure and coherent original analysis concerning the consequences of implementing of each proposal from the EU package on "climate change and energy" towards Romania.

For long term, the attention should be given to Carbon Capture and Storage technologies, which involve the capture, transport and geological storage of CO<sub>2</sub>, applied especially to electricity producers and highly polluting industries.

The main scope consists of developing a methodology that predicts the costs for CO<sub>2</sub> rich technologies to be paid. It is based on ten case studies, representative for Romania.

The research was carried out according to the following steps: (i) analysis of the current situation and projected evolution of industrial sectors in Romania; (ii) identification of the costs induced by the application of the EU legislative package on the types of industrial activities, by means of an original mathematical model created; and (iii) cost evolution induced by the legislative package for the period 2013-2020.

The investigation carried out has clearly shown that the most affected sectors are those which produce electricity and heat. These sectors emit the largest amount of CO<sub>2</sub> per unit of production. It means they will obviously have to buy the largest quantity of emission allowances.

In parallel, one demonstrated that industrial sectors consuming electrical energy for the production processes are affected by the large quantities of emissions generated into the atmosphere and, indirectly, by the amount of electricity purchased. Thus, production costs will increase by 20-70% compared to 2009, depending on the type of industrial activity.

In terms of application of legislative provisions stipulated by Directive 2009/29/EC, starting from 2013, the mitigation of greenhouse gas emissions becomes a priority for each state. All industrial units will be able to keep their competitiveness on the market through: optimization of industrial processes and improvement of energy efficiency.

## Table of contents

<b>List of figures.....</b>	<b>8</b>
<b>List of tables.....</b>	<b>13</b>
<b>Nomenclature.....</b>	<b>14</b>
<b>1 EU Emissions Trading Scheme.....</b>	<b>16</b>
1.1 ETS industrial activities.....	16
1.1.1 Overview of the Romanian facilities covered by EU-ETS and their share in sector’s total emissions.....	16
1.1.2 Certificates allocated for the periods 2007 and 2008-2012.....	18
1.2 Industrial activities to be included in the EU-ETS for the period 2013-2020.....	22
1.2.1 Production and processing of ferrous metals (including ferro-alloys).....	24
1.2.2 Production of primary aluminium.....	28
1.2.3 Production and processing of non-ferrous metals (including production of alloys, refining, foundry, casting).....	30
1.2.4 Manufacture of mineral wool insulation material using glass, rock or slag.....	31
1.2.5 Production of carbon black involving the carbonization of some organic substances (oils, tars, cracker and distillation residues).....	33
1.2.6 Production of nitric acid.....	35
1.2.7 Production of ammonia.....	35
1.2.8 Production of soda ash and sodium bicarbonate.....	36
1.3 Aim of the study.....	40
1.4 Main objective.....	40
<b>2 The EU climate-energy legislative package.....</b>	<b>41</b>
<b>3 Structure of production costs.....</b>	<b>48</b>
3.1 General aspects.....	48
3.2 Structure of production costs for industrial activities covered by the EU ETS.....	48
3.2.1 Energy activities.....	49
3.2.2 Production and processing of ferrous metals.....	51
3.2.3 Mineral industry.....	52
3.2.4 Pulp and paper sector.....	54
3.3 Structure of production activities that will be covered by the EU ETS for the period 2013-2020.....	55
3.3.1 Energy and lime sector.....	55
3.3.2 Existing ETS activity to which after 2012 will be added a new ETS activity with other emission sources.....	56

3.4	Structure of production costs for non ETS production activities .....	57
3.4.1	Existing ETS activity for 2008-2012, which from 2013 onwards becomes non ETS.....	57
3.4.2	Non ETS activity that becomes after 2012 a new ETS.....	57
<b>4</b>	<b>ETS cost impacts on production costs for representative installations in 2013 .....</b>	<b>59</b>
4.1	Presentation of case studies.....	59
4.2	Impact of acquisition and transaction costs of allowances on current production costs for representative installations .....	63
4.2.1	Energy activities.....	73
4.2.2	Production and processing of ferrous metals .....	90
4.2.3	Mineral industry (cement, lime, glass and ceramic) .....	94
4.2.4	Pulp and paper.....	113
4.2.5	Energy and lime.....	117
4.2.6	Chemical industry.....	122
4.2.7	Non-ferrous metals.....	123
<b>5</b>	<b>Impact of the ETS costs on industrial activities in 2013.....</b>	<b>125</b>
5.1	Methodology for monitoring of CO <sub>2</sub> emissions from combustion units .....	141
5.1.1	Methodology for monitoring of combustion emissions, correlated with levels of approach .....	141
5.1.2	Methodology for monitoring of process emissions, correlated with levels of approach .....	143
5.2	Mathematical formulae .....	144
<b>6</b>	<b>Carbon dioxide capture and storage .....</b>	<b>147</b>
6.1	Greenhouse gas emissions .....	147
6.2	CO <sub>2</sub> capture .....	150
6.2.1	Post-combustion CO <sub>2</sub> capture .....	150
6.2.2	Oxy-fuel combustion.....	153
6.2.3	Pre-combustion CO <sub>2</sub> capture.....	154
6.3	CO <sub>2</sub> emissions from power plant.....	155
6.4	Efficiency of a power plant with CO <sub>2</sub> capture.....	156
6.5	Transportation of CO <sub>2</sub> .....	158
6.6	Storage of CO <sub>2</sub> .....	159
6.6.1	Geological formations.....	159
6.6.2	Ocean storage .....	160
6.7	Costs.....	161
6.7.1	Costs of power generation with and without CO <sub>2</sub> capture.....	161
6.7.2	Costs of CO <sub>2</sub> transport and storage.....	163

---

<b>7</b>	<b>Conclusions and abstract .....</b>	<b>165</b>
7.1	Abstract .....	165
7.2	General conclusions .....	167
7.3	Study conclusions .....	169
7.4	Personal contributions .....	173
7.5	Recommendations .....	173
	<b>References.....</b>	<b>174</b>
	<b>Annex A: Questionnaire sent to operators.....</b>	<b>184</b>
	<b>Annex B: CCS Projects.....</b>	<b>188</b>
	<b>Rezumatul tezei de doctorat.....</b>	<b>189</b>

## List of figures

Figure 1.1. Number of Romanian installations included in ETS for 2007 (in round brackets for the period 2008-2012) .....	18
Figure 1.2. Number of certificates allocated for each sector for 2007 (in round brackets for the period 2008-2012) .....	19
Figure 1.3. Verified emissions of CO <sub>2</sub> for 2007 and 2008.....	22
Figure 1.4. Use of ferro-alloys in different industrial sectors in 1994 .....	24
Figure 1.5. EU production of bulk ferro-alloys .....	25
Figure 1.6. Production of primary aluminium in 2008 .....	28
Figure 1.7. Number of mineral wool installations in EU .....	32
Figure 1.8. Production capacity of carbon black in Europe, in 2002 .....	34
Figure 1.9. Ammonia production at the European level .....	36
Figure 1.10. Production of soda ash in Europe, in 2002.....	37
Figure 1.11. Production of sodium bicarbonate in Europe, in 2002 .....	39
Figure 3.1. Structure of unit cost of production for 2007 and 2008 (Installation no. 1) .....	49
Figure 3.2. Structure of total annual production costs (Installation no. 2).....	50
Figure 3.3. Structure of unit cost of production for thermal energy (Installation no. 2) .....	50
Figure 3.4. Structure of unit cost of production for electrical and thermal energy (Installation no. 2) .....	50
Figure 3.5. Structure of unit cost of production (Installation no. 3).....	51
Figure 3.6. Structure of unit cost of production (Installation no. 4).....	52
Figure 3.7. Structure of unit cost of production (Installation no. 5).....	53
Figure 3.8. Structure of unit cost of production (Installation no. 6).....	53
Figure 3.9. Structure of unit cost of production (Installation no. 7).....	54
Figure 3.10. Structure of unit cost of production (Installation no. 8) .....	54
Figure 3.11. Structure of unit cost of production (Installation no. 9) .....	55
Figure 3.12. Structure of unit cost of production (Installation no. 10).....	56
Figure 3.13. Structure of unit cost of production (Installation no. 11).....	56
Figure 3.14. Structure of unit cost of production (Installation no. 12).....	57
Figure 3.15. Structure of unit cost of production (Installation no. 13).....	58
Figure 4.1. Impact of costs for purchasing and trading of allowances, in 2013, (Installation no. 1 – Case study 0) .....	74
Figure 4.2. Impact of costs for purchasing and trading of allowances, in 2013, (Installation no. 1 – Case study 1) .....	75
Figure 4.3. Impact of costs for purchasing and trading of allowances, in 2013, (Installation no. 1 – Case study 2) .....	75
Figure 4.4. Impact of costs for purchasing and trading of allowances, in 2013, (Installation no. 1 – Case study 3) .....	76
Figure 4.5. Impact of costs for purchasing and trading of allowances, in 2013, (Installation no. 1 – Case study 4) .....	76
Figure 4.6. Impact of costs for purchasing and trading of allowances, in 2013, (Installation no. 1 – Case study 5) .....	77
Figure 4.7. Investment in energy efficiency (Installation no. 1).....	78



Figure 4.8. Impact of costs for purchasing and trading of allowances, in 2013, (top) electrical energy and (bottom) thermal energy, (Installation no. 2 – Case study 0).....	79
Figure 4.9. Impact of costs for purchasing and trading of allowances, in 2013, (top) electrical energy and (bottom) thermal energy, (Installation no. 2 – Case study 1).....	80
Figure 4.10. Impact of costs for purchasing and trading of allowances, in 2013, (top) electrical energy and (bottom) thermal energy, (Installation no. 2 – Case study 2).....	81
Figure 4.11. Impact of costs for purchasing and trading of allowances, in 2013, (top) electrical energy and (bottom) thermal energy, (Installation no. 2 – Case study 3).....	82
Figure 4.12. Impact of costs for purchasing and trading of allowances, in 2013, (top) electrical energy and (bottom) thermal energy, (Installation no. 2 – Case study 4).....	83
Figure 4.13. Impact of costs for purchasing and trading of allowances, in 2013, (top) electrical energy and (bottom) thermal energy, (Installation no. 2 – Case study 5).....	84
Figure 4.14. Investment in energy efficiency (Installation no. 2).....	85
Figure 4.15. Impact of costs for purchasing and trading of allowances, in 2013, (top) without COE and (bottom) with COE, (Installation no. 3 – Case study 0).....	86
Figure 4.16. Impact of costs for purchasing and trading of allowances, in 2013, (Installation no. 3 – Case study 1).....	87
Figure 4.17. Impact of costs for purchasing and trading of allowances, in 2013, (Installation no. 3 – Case study 2).....	87
Figure 4.18. Impact of costs for purchasing and trading of allowances, in 2013, (Installation no. 3 – Case study 3).....	88
Figure 4.19. Impact of costs for purchasing and trading of allowances, in 2013, (Installation no. 3 – Case study 4).....	88
Figure 4.20. Impact of costs for purchasing and trading of allowances, in 2013, (Installation no. 3 – Case study 5).....	89
Figure 4.21. Investment in energy efficiency (Installation no. 3).....	89
Figure 4.22. Impact of costs for purchasing and trading of allowances, in 2013, (top) without COE and (bottom) with COE, (Installation no. 4 – Case study 0).....	90
Figure 4.23. Impact of costs for purchasing and trading of allowances, in 2013, (Installation no. 4 – Case study 1).....	91
Figure 4.24. Impact of costs for purchasing and trading of allowances, in 2013, (Installation no. 4 – Case study 2).....	92
Figure 4.25. Impact of costs for purchasing and trading of allowances, in 2013, (Installation no. 4 – Case study 3).....	92
Figure 4.26. Impact of costs for purchasing and trading of allowances, in 2013, (Installation no. 4 – Case study 4).....	93
Figure 4.27. Impact of costs for purchasing and trading of allowances, in 2013, (Installation no. 4 – Case study 5).....	93
Figure 4.28. Investment in energy efficiency (Installation no. 4).....	94
Figure 4.29. Impact of costs for purchasing and trading of allowances, in 2013, (top) without COE and (bottom) with COE, (Installation no. 5 – Case study 0).....	95

Figure 4.30. Impact of costs for purchasing and trading of allowances, in 2013, (Installation no. 5 – Case study 1) .....	96
Figure 4.31. Impact of costs for purchasing and trading of allowances, in 2013, (Installation no. 5 – Case study 2) .....	97
Figure 4.32. Impact of costs for purchasing and trading of allowances, in 2013, (Installation no. 5 – Case study 3) .....	97
Figure 4.33. Impact of costs for purchasing and trading of allowances, in 2013, (Installation no. 5 – Case study 4) .....	98
Figure 4.34. Impact of costs for purchasing and trading of allowances, in 2013, (Installation no. 5 – Case study 5) .....	98
Figure 4.35. Investment in energy efficiency (Installation no. 5) .....	99
Figure 4.36. Impact of costs for purchasing and trading of allowances, in 2013, (top) without COE and (bottom) with COE, (Installation no. 6 – Case study 0) .....	100
Figure 4.37. Impact of costs for purchasing and trading of allowances, in 2013, (Installation no. 6 – Case study 1) .....	101
Figure 4.38. Impact of costs for purchasing and trading of allowances, in 2013, (Installation no. 6 – Case study 2) .....	101
Figure 4.39. Impact of costs for purchasing and trading of allowances, in 2013, (Installation no. 6 – Case study 3) .....	102
Figure 4.40. Impact of costs for purchasing and trading of allowances, in 2013, (Installation no. 6 – Case study 4) .....	102
Figure 4.41. Impact of costs for purchasing and trading of allowances, in 2013, (Installation no. 6 – Case study 5) .....	103
Figure 4.42. Investment in energy efficiency (Installation no. 6) .....	103
Figure 4.43. Impact of costs for purchasing and trading of allowances, in 2013, (top) without COE and (bottom) with COE, (Installation no. 7 – Case study 0) .....	104
Figure 4.44. Impact of costs for purchasing and trading of allowances, in 2013, (Installation no. 7 – Case study 1) .....	105
Figure 4.45. Impact of costs for purchasing and trading of allowances, in 2013, (Installation no. 7 – Case study 2) .....	106
Figure 4.46. Impact of costs for purchasing and trading of allowances, in 2013, (Installation no. 7 – Case study 3) .....	106
Figure 4.47. Impact of costs for purchasing and trading of allowances, in 2013, (Installation no. 7 – Case study 4) .....	107
Figure 4.48. Impact of costs for purchasing and trading of allowances, in 2013, (Installation no. 7 – Case study 5) .....	107
Figure 4.49. Investment in energy efficiency (Installation no. 7) .....	108
Figure 4.50. Impact of costs for purchasing and trading of allowances, in 2013, (top) without COE and (bottom) with COE, (Installation no. 8 – Case study 0) .....	109
Figure 4.51. Impact of costs for purchasing and trading of allowances, in 2013, (Installation no. 8 – Case study 1) .....	110
Figure 4.52. Impact of costs for purchasing and trading of allowances, in 2013, (Installation no. 8 – Case study 2) .....	110
Figure 4.53. Impact of costs for purchasing and trading of allowances, in 2013, (Installation no. 8 – Case study 3) .....	111
Figure 4.54. Impact of costs for purchasing and trading of allowances, in 2013, (Installation no. 8 – Case study 4) .....	111

Figure 4.55. Impact of costs for purchasing and trading of allowances, in 2013, (Installation no. 8 – Case study 5).....	112
Figure 4.56. Investment in energy efficiency (Installation no. 8).....	112
Figure 4.57. Impact of costs for purchasing and trading of allowances, in 2013, (top) without COE and (bottom) with COE, (Installation no. 9 – Case study 0).....	113
Figure 4.58. Impact of costs for purchasing and trading of allowances, in 2013, (Installation no. 9 – Case study 1).....	114
Figure 4.59. Impact of costs for purchasing and trading of allowances, in 2013, (Installation no. 9 – Case study 2).....	115
Figure 4.60. Impact of costs for purchasing and trading of allowances, in 2013, (Installation no. 9 – Case study 3).....	115
Figure 4.61. Impact of costs for purchasing and trading of allowances, in 2013, (Installation no. 9 – Case study 4).....	116
Figure 4.62. Impact of costs for purchasing and trading of allowances, in 2013, (Installation no. 9 – Case study 5).....	116
Figure 4.63. Investment in energy efficiency (Installation no. 9).....	117
Figure 4.64. Impact of costs for purchasing and trading of allowances, in 2013, (top) without COE and (bottom) with COE, (Installation no. 10 – Case study 0).....	118
Figure 4.65. Impact of costs for purchasing and trading of allowances, in 2013, (Installation no. 10 – Case study 1).....	119
Figure 4.66. Impact of costs for purchasing and trading of allowances, in 2013, (Installation no. 10 – Case study 2).....	119
Figure 4.67. Impact of costs for purchasing and trading of allowances, in 2013, (Installation no. 10 – Case study 3).....	120
Figure 4.68. Impact of costs for purchasing and trading of allowances, in 2013, (Installation no. 10 – Case study 4).....	120
Figure 4.69. Impact of costs for purchasing and trading of allowances, in 2013, (Installation no. 10 – Case study 5).....	121
Figure 4.70. Investment in energy efficiency (Installation no. 10).....	121
Figure 4.71. Impact of costs for purchasing and trading of allowances, in 2013, (Installation no. 11 – Case study 1).....	122
Figure 4.72. Impact of costs for purchasing and trading of allowances, in 2013, (Installation no. 11 – Case study 4).....	123
Figure 4.73. Impact of costs for purchasing and trading of allowances, in 2013, (Installation no. 12 – Case study 1).....	124
Figure 4.74. Impact of costs for purchasing and trading of allowances, in 2013, (Installation no. 12 – Case study 4).....	124
Figure 6.1. Global anthropogenic greenhouse gas emissions in 2004.....	147
Figure 6.2. World CO <sub>2</sub> emissions by sector in 2007.....	148
Figure 6.3. World and EU27 emissions of CO <sub>2</sub> in 2007, by fuel.....	149
Figure 6.4. Capture, transportation and storage of CO <sub>2</sub> .....	150
Figure 6.5. Post-combustion CO <sub>2</sub> capture (absorption process).....	151
Figure 6.6. Process flow diagram for a typical amine separation process.....	152
Figure 6.7. Oxy-combustion CO <sub>2</sub> capture (O <sub>2</sub> /CO <sub>2</sub> recycle).....	153
Figure 6.8. Pre-combustion CO <sub>2</sub> capture (decarbonisation process).....	154
Figure 6.9. Capital costs and cost of electricity for different generation technologies.....	162

---

Figure 7.1. Additional specific costs, Base Scenario, 20% reduction, 15 €/certificate .....	171
Figure 7.2. Additional specific costs, Base Scenario, 20% reduction, 40 €/certificate .....	172

## List of tables

Table 1.1. Description of industrial activities.....	16
Table 1.2. Number of installations included in ETS for each sector and their share.....	17
Table 1.3. Total number of certificates allocated for each sector.....	18
Table 1.4. Industrial fields of activity in the energy sector.....	19
Table 1.5. Energy sector (number of installations).....	20
Table 1.6. Total number of certificates allocated to energy sector.....	20
Table 1.7. New industrial sectors included in the EU-ETS .....	23
Table 1.8. Specific consumption of raw materials and energy for the production of ferro-chrome .....	26
Table 1.9. Specific consumption of raw material and energy by producing FeSi, Si and CaSi .....	26
Table 1.10. Specific consumption for the production of manganese ore sinter, FeMn and SiMn .....	27
Table 1.11. Specific consumption for the production of special ferro-alloys.....	27
Table 1.12. Emissions of CO <sub>2</sub> from the production of bulk ferro-alloys .....	27
Table 1.13. Consumption of raw material and energy for the production of alumina .....	29
Table 1.14. Consumption of raw material and energy in the process of electrolysis .....	29
Table 1.15. Raw materials/fuels used for the production of mineral wool .....	32
Table 1.16. Total energy consumption for the production of mineral wool .....	32
Table 1.17. CO <sub>2</sub> emissions from mineral wool melting/final processes .....	33
Table 1.18. Consumption of raw materials and energy.....	34
Table 1.19. Consumption of raw materials and energy for the production of nitric acid.....	35
Table 1.20. Consumption and emissions of the Solvay soda ash process.....	38
Table 4.1. Presentation of different case studies with different allowance price.....	60
Table 4.2. Share of additional costs for purchasing and trading of allowances, due to the application of the greenhouse gas emission trading scheme.....	65
Table 5.1. Impact of the legislative package on industrial activities covered by ETS.....	126
Table 5.2. Emission factor and net calorific value of various fuels .....	141
Table 5.3. Stoichiometric ratios .....	144
Table 5.4. Formulae for calculation of costs .....	145
Table 6.1. CO <sub>2</sub> emissions from fossil fuel power plants .....	156
Table 6.2. Thermal efficiency of power plants with and without CO <sub>2</sub> capture .....	157
Table 7.1. Case studies analyzed .....	166
Table 7.2. Cost estimation.....	167

## Nomenclature

AD	Activity Data
ASU	Air Separation Unit
BF	Blast Furnace
CBM	Coal Bed Methane
COE	Cost of Electricity
EAFF	Electric Arc Furnace
EC	European Commission
EF	Emission Factor
EOR	Enhanced Oil Recovery
ETS	Emissions Trading Scheme
FGD	Flue Gas Desulphurization
GD	Government Decision
GDP	Gross Domestic Product
GHG	Greenhouse Gas
GWP	Global Warming Potential
IEA	International Energy Agency
IGCC	Integrated Gasification Combined Cycle
IPCC	Intergovernmental Panel on Climate Change
NAP	National Allocation Plan
NCV	Net Calorific Value
NETL	National Energy Technology Laboratory
NGCC	Natural Gas Combined Cycle
OF	Oxidation Factor
PC	Pulverized Coal
SCR	Selective Catalytic Reduction
UCTE	Union for the Coordination of Transmission of Electricity
UNFCCC	United Nations Framework Convention on Climate Change
n.a.	not applicable
n.r.	not relevant
Ca(OH) <sub>2</sub>	Calcium hydroxide
CaCl <sub>2</sub>	Calcium chloride
CaCO <sub>3</sub>	Calcium carbonate
CaO	Calcium oxide
CaSO <sub>4</sub>	Calcium sulfate
CH <sub>4</sub>	Methane
CO	Carbon monoxide
CO <sub>2</sub>	Carbon dioxide
COS	Carbonyl sulfide
FeCr	Ferro-chrome
FeMn	Ferro-manganese
H <sub>2</sub> S	Hydrogen sulfide
HNO <sub>3</sub>	Nitric acid
LC, MC, HC	Low-, Medium-, High-Carbon
MDEA	Methyldiethanolamine
MEA	Monoethanolamine

---

Mg(OH) <sub>2</sub>	Magnesium hydroxide
MgCO <sub>3</sub>	Magnesium carbonate
N <sub>2</sub> O	Nitrous oxide
Na <sub>2</sub> CO <sub>3</sub>	Sodium carbonate
NaCl	Sodium chloride
NaHCO <sub>3</sub>	Sodium bicarbonate
NaOH	Sodium hydroxide
NH <sub>3</sub>	Ammonia
NH <sub>4</sub> Cl	Ammonium chloride
NH <sub>4</sub> HCO <sub>3</sub>	Ammonium bicarbonate
NH <sub>4</sub> OH	Ammonium hydroxide
(NH <sub>4</sub> ) <sub>2</sub> CO <sub>3</sub>	Ammonium carbonate
NO	Nitric oxide
NO <sub>2</sub>	Nitrogen dioxide
NO <sub>x</sub>	Nitrogen oxides
PAHs	Poly-aromatic hydrocarbons
PFCs	Poly-fluorinated carbons
SiCa	Silico-calcium
SiMn	Silico-manganese
SO <sub>2</sub>	Sulfur dioxide

# 1 EU Emissions Trading Scheme

According to the Kyoto Protocol, the European Union is committed to reducing greenhouse gas emissions by 8% below its 1990 level during the period 2008-2012 [I1].

The EU-ETS currently covers more than 10000 installations in the energy and industrial sectors which are collectively responsible for close to half of the EU's emissions of CO<sub>2</sub> and 40% of its total greenhouse gas emissions. Industries covered by the scheme include: power generation, iron and steel, glass, cement, pottery and bricks [E1, E2, R1, R2, S3, W1].

## 1.1 ETS industrial activities

### 1.1.1 Overview of the Romanian facilities covered by EU-ETS and their share in sector's total emissions

According to the Romanian National Allocation Plan (NAP) for the periods 2007 and 2008-2012, there have been identified eight industrial sectors [R6, R4]:

- Energy;
- Refineries;
- Production or processing of ferrous metals;
- Cement production;
- Lime production;
- Manufacture of glass including glass fibre;
- Manufacture of ceramic products;
- Pulp, paper and board production.

Correlation between those eight industrial sectors defined in NAP [R6] and activities provided in Annex 1 of the Romanian Government Decision 780/2006 [R3], concerning the establishment of a greenhouse gas emission trading scheme, is shown in Table 1.1.

Table 1.1. Description of industrial activities

Sectors defined in NAP	Activities defined in Annex 1 of GD 780/2006
Energy	Energy activities: <ul style="list-style-type: none"><li>- Combustion installations with a rated thermal input exceeding 20 MW (except hazardous or municipal waste installations)</li></ul>
Refineries	Energy activities: <ul style="list-style-type: none"><li>- Installations for oil refining</li></ul>
Production and processing of ferrous metals	Production and processing of ferrous metals: <ul style="list-style-type: none"><li>- Installations for metal ore (including sulphide ore) roasting or sintering</li><li>- Installations for the production of pig iron or steel (primary or secondary fusion) including continuous casting, with a capacity exceeding 2.5 t/h</li></ul>



Table 1.1 (continued)

Cement production	Mineral industry: – Installations for the production of cement clinker in rotary kilns with a production capacity exceeding 500 t/day or in other furnaces with a production capacity exceeding 50 t/day
Lime production	Mineral industry: – Installations for the production of lime in rotary kilns or in other furnaces with a production capacity exceeding 50 t/day
Manufacture of glass including glass fibre	Mineral industry: – Installations for the manufacture of glass including glass fibre with a melting capacity exceeding 20 t/d
Manufacture of ceramic products	Mineral industry: – Installations for the manufacture of ceramic products by firing, in particular roofing tiles, bricks, refractory bricks, tiles, stoneware or porcelain, with a production capacity exceeding 75 t/day, and/or with a kiln capacity exceeding 4 m <sup>3</sup> and with a setting density per kiln exceeding 300 kg/m <sup>3</sup>
Pulp, paper and board production	Other activities: – Industrial plants for the production of pulp from timber or other fibrous materials and for the production of paper and board with a production capacity exceeding 20 t/day

Total number of existing installations included in Annex 1 of GD 780/2006, is as follows [R3]:

- for 2007 a number of 244 installations;
- for period 2008-2012 a number of 229.

Table 1.2 and Figure 1.1, respectively, show the number of installations for each sector included in ETS for the periods 2007 and 2008-2012.

Table 1.2. Number of installations included in ETS for each sector and their share

Sectors	2007		2008-2012	
	number of installations	share, %	number of installations	share, %
Energy	152	62.30	146	63.76
Refineries	9	3.68	9	3.92
Production and processing of ferrous metals	18	7.38	15	6.55
Cement production	7	2.87	7	3.06
Lime production	9	3.68	7	3.06
Manufacture of glass including glass fibre	8	3.28	7	3.06
Manufacture of ceramic products	30	12.30	28	12.22
Pulp, paper and board production	11	4.51	10	4.37
<b>Total number of installations</b>	<b>244</b>		<b>229</b>	

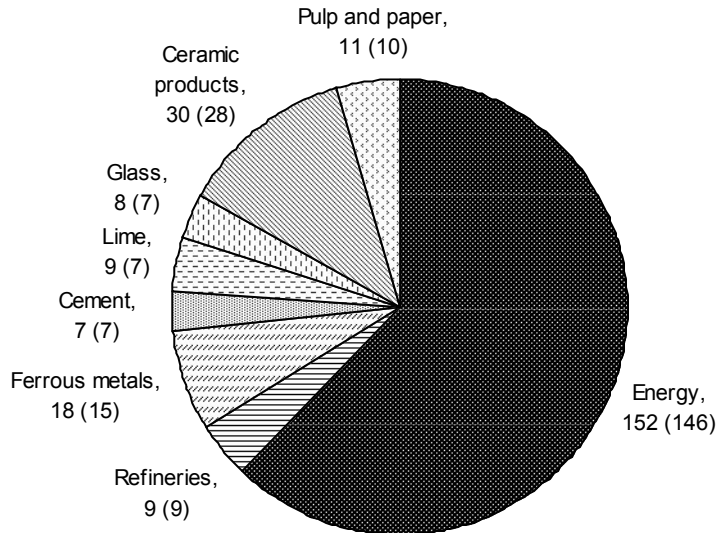

Figure 1.1. Number of Romanian installations included in ETS for 2007 (in round brackets for the period 2008-2012)

### 1.1.2 Certificates allocated for the periods 2007 and 2008-2012

The total number of certificates allocated for the first and second phase of the EU-ETS according to GD 60/2008 [R4] is indicated in Table 1.3 and Figure 1.2.

Table 1.3. Total number of certificates allocated for each sector

Sectors	2007		2008-2012	
	number of certificates	share, %	number of certificates	share, %
Energy	46963995	63.17	207842393	59.44
Refineries	6286751	8.46	28818122	8.24
Production and processing of ferrous metals	11835763	15.92	61654319	17.63
Cement production	6895003	9.27	40626885	11.62
Lime production	1102910	1.48	4908313	1.40
Manufacture of glass including glass fibre	392974	0.54	1618308	0.47
Manufacture of ceramic products	403194	0.54	1753842	0.50
Pulp, paper and board production	462766	0.62	2449411	0.70
<b>Total number of certificates</b>	<b>74343356</b>		<b>349671593</b>	

\*number of certificates under JI are not included

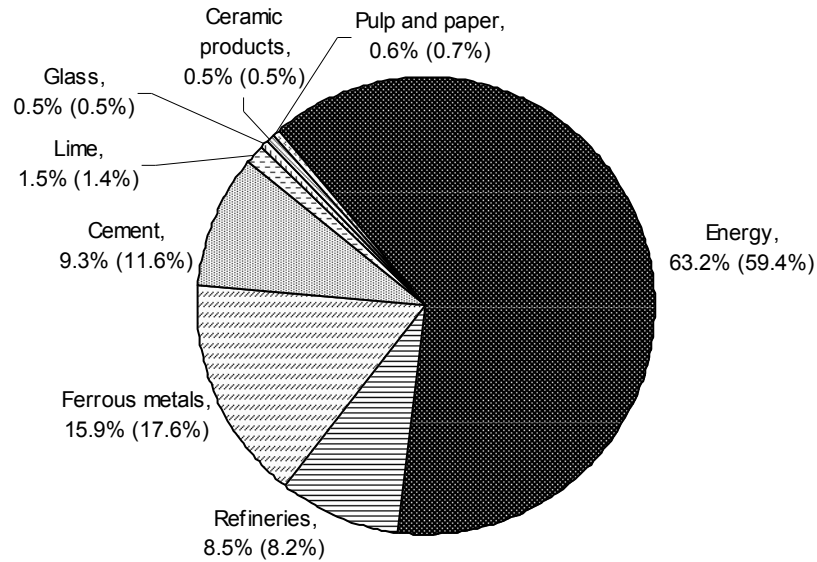

Figure 1.2. Number of certificates allocated for each sector for 2007 (in round brackets for the period 2008-2012)

Fields of activity related to installations from the energy sector are presented in Table 1.4.

Table 1.4. Industrial fields of activity in the energy sector

Field of activity	Specific field of activity
Energy production industry	<ul style="list-style-type: none"> <li>- electricity production</li> <li>- electricity and thermal energy production</li> <li>- thermal energy production</li> </ul>
Other industries	<ul style="list-style-type: none"> <li>- chemical</li> <li>- wood</li> <li>- automotive</li> <li>- oil</li> <li>- aviation</li> <li>- food</li> <li>- electrical</li> <li>- pharmaceutical</li> <li>- abrasive products</li> <li>- ceramic</li> <li>- petrochemical</li> <li>- ferrous metals</li> <li>- rolling stock</li> <li>- tire</li> <li>- non-ferrous metals</li> <li>- chemical fertilizers</li> <li>- carbonated products</li> <li>- technological equipment</li> </ul>

In 2007, within this sector, there were included a number of 152 of the existing combustion installations. For 2008-2012 this number has been reduced to 146.

The structure of energy sector, from the point of view of the total number of installations and fields of activity, is presented in Table 1.5.

Table 1.5. Energy sector (number of installations)

Field of activity	2007		2008-2012	
	number of installations	share, %	number of installations	share, %
Energy production industry:				
– electricity production	7	4.61	7	4.79
– electricity and thermal energy production	37	24.34	37	25.34
– thermal energy production	23	15.13	18	12.33
<b>Total (energy industry)</b>	<b>67</b>	<b>44.08</b>	<b>62</b>	<b>42.47</b>
Other industries:				
– chemical	10	6.58	10	6.85
– wood	10	6.58	10	6.85
– automotive	5	3.29	5	3.42
– oil	19	12.50	18	12.33
– aviation	2	1.32	2	1.37
– food	15	9.87	15	10.27
– electrical	1	0.66	1	0.68
– pharmaceutical	1	0.66	1	0.68
– abrasive products	1	0.66	1	0.68
– ceramic	2	1.32	2	1.37
– petrochemical	1	0.66	1	0.68
– ferrous metals	4	2.63	4	2.74
– rolling stock	1	0.66	1	0.68
– tire	5	3.29	5	3.42
– non-ferrous metals	5	3.29	5	3.42
– chemical fertilizers	1	0.66	1	0.68
– carbonated products	1	0.66	1	0.68
– technological equipment	1	0.66	1	0.68
<b>Total (other industries)</b>	<b>85</b>	<b>55.92</b>	<b>84</b>	<b>57.53</b>
<b>Total</b>	<b>152</b>		<b>146</b>	

The total amount of allowances allocated by Romania's NAP [R6] for the energy sector according to GD 60/2008 [R4] is indicated in Table 1.6.

Table 1.6. Total number of certificates allocated to energy sector

Field of activity	Allocation for 2007	Allocation for 2008-2012
Energy production industry:		
– electricity production	17323135	76979943
– electricity and thermal energy production	21912584	96968909
– thermal energy production	631109	2672976
<b>Total (energy industry)</b>	<b>39866828</b>	<b>176621828</b>

Table 1.6 (continued)

Other industries:		
– chemical	1951226	8548456
– wood	182973	871419
– automotive	291788	1252163
– oil	1271333	5499125
– aviation	10701	46977
– food	518507	2225730
– electrical	4650	20617
– pharmaceutical	9282	41150
– abrasive products	3681	16119
– ceramic	50630	239065
– petrochemical	111443	494068
– ferrous metals	127529	618874
– rolling stock	5391	23900
– tire	131608	637646
– non-ferrous metals	1150720	5086865
– chemical fertilizers	1223751	5348045
– carbonated products	20002	109770
– technological equipment	31952	140576
<b>Total (other industries)</b>	<b>7097167</b>	<b>31220565</b>
<b>Total</b>	<b>46963995</b>	<b>207842393</b>

As can be seen from Table 1.6, for the periods 2007 and 2008-2012, more than 84% of the total number of allowances is allocated to the energy production industry. The largest number of certificates of about 47% is allocated to power stations designed for the electricity and thermal energy generation.

Figure 1.3 shows the total amount of verified emissions of the CO<sub>2</sub> from different EU-ETS installations. It is easily noted that in 2008 the verified emissions were lower than in 2007 (by approximately 8%). This is mainly attributed to: (i) decrease in production; and partially, (ii) use of the CO<sub>2</sub> mitigation measures.

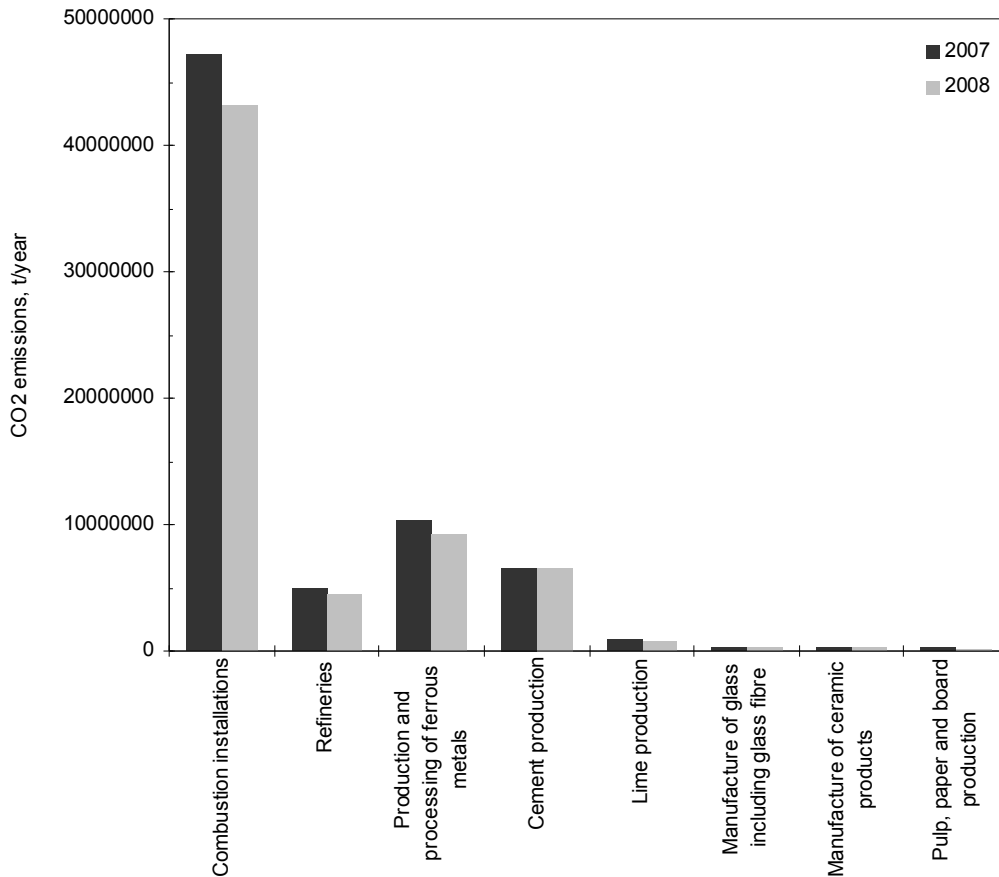

Figure 1.3. Verified emissions of CO<sub>2</sub> for 2007 and 2008

## 1.2 Industrial activities to be included in the EU-ETS for the period 2013-2020

In order to improve and extend the greenhouse gas emission allowance trading scheme, in 2009, a new Directive of the European Parliament and of the Council was released (Directive 2009/29/EC) [E2]. From 2013, in accordance with this Directive, the following new industrial sectors will be included in the EU-ETS, Table 1.7.

Table 1.7. New industrial sectors included in the EU-ETS

Activities	Condition to be included in EU-ETS	GHGs	Remarks
<i>Production and processing of ferrous metals</i>			
Production or processing of ferrous metals (including ferro-alloys). Processing includes inter alia, rolling mills, re-heaters, annealing furnaces, smitheries, foundries, coating and pickling	Combustion units with a total rated thermal input exceeding 20 MW	CO <sub>2</sub>	Already included in the EU-ETS in the section "combustion installations"
Production of primary aluminium	-	CO <sub>2</sub> PFCs	One installation*
Production of secondary aluminium	Combustion units with a total rated thermal input exceeding 20 MW	CO <sub>2</sub>	Already included in the EU-ETS in the section "combustion installations"
Production or processing of non-ferrous metals, including production of alloys, refining, foundry, casting, etc.	Combustion units with a total rated thermal input exceeding 20 MW, including fuels used as reducing agents	CO <sub>2</sub>	Already included in the EU-ETS in the section "combustion installations"
<i>Mineral industry</i>			
Manufacture of mineral wool insulation material using glass, rock or slag	Melting capacity exceeding 20 t/day	CO <sub>2</sub>	-
Drying or calcinations of gypsum or production of plaster boards and other gypsum products	Combustion units with a total rated thermal input exceeding 20 MW	CO <sub>2</sub>	Already included in the EU-ETS in the section "combustion installations"
<i>Chemical industry</i>			
Production of carbon black involving the carbonization of organic substances such as oils, tars, cracker and distillation residues	Combustion units with a total rated thermal input exceeding 20 MW	CO <sub>2</sub>	Already included in the EU-ETS in the section "combustion installations"
Production of nitric acid	-	CO <sub>2</sub> N <sub>2</sub> O	Two installations are shut down in 1990 and 2006, respectively*
Production of adipic acid	-	CO <sub>2</sub> N <sub>2</sub> O	One installation with suspended activity from 2002*
Production of glyoxal and glyoxylic acid	-	CO <sub>2</sub> N <sub>2</sub> O	-
Production of ammonia	-	CO <sub>2</sub>	Six installations
Production of bulk organic chemicals by cracking, reforming, partial or full oxidation	Production capacity exceeding 100 t/day	CO <sub>2</sub>	
Production of hydrogen and synthesis gas by reforming or partial oxidation	Production capacity exceeding 25 t/day	CO <sub>2</sub>	Eight installations**
Production of soda ash and sodium bicarbonate	-	CO <sub>2</sub>	Two installations***

### 1.2.1 Production and processing of ferrous metals (including ferro-alloys)

Ferro-alloys are master alloys containing some iron and one or more non-ferrous metals as alloying elements (silicon, manganese, chromium, molybdenum, vanadium or tungsten) [E12].

Ferro-alloys are classified in two groups:

- Bulk ferro-alloys (ferro-chrome, ferro-silicon together with silicon-metal, ferro-manganese and silico-manganese), which are produced in large quantities in electric furnaces and used exclusively in steel making and steel or iron foundries;
- Special ferro-alloys (ferro-titanium, ferro-vanadium, ferro-tungsten, ferro-niobium, ferro-molybdenum, ferro-boron and ternary/quaternary alloys), which are produced in smaller quantities, but with growing importance. They are used in the aluminium and chemical industries, especially silicon production.

Ferro-alloys are used in different industrial sectors, which are presented in Figure 1.4.

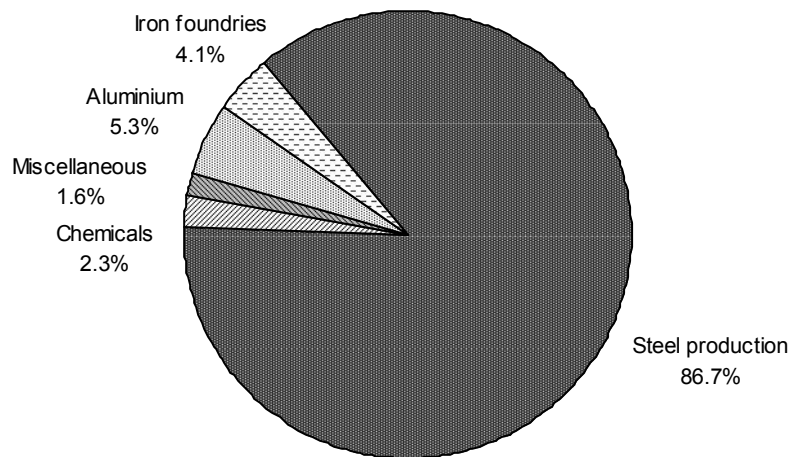

Figure 1.4. Use of ferro-alloys in different industrial sectors in 1994

Over the last 15 to 20 years, the world pattern of the ferro-alloy market has deeply changed: (i) the consumption of the developing countries has vastly increased with the development of their steel production; (ii) their production has even more increased because they have taken a growing share of the traditional markets of the industrial countries, where the steel production was stagnant or growing at a slow rate; (iii) the ferro-alloy industry is facing a growing proportion of imports, at first from the new industrialized countries and in recent years from the countries of East Europe and Russia.

As a consequence, the production of ferro-alloys in Europe has been submitted to a difficult competition that results in a decreasing trend of the total amount of ferro-alloys produced.



The production rate of bulk ferro-alloys in the EU for the period 1993-1997 expressed in tonnes per year is shown in Figure 1.5. It should be noted that Norway (non-EU member state) produces yearly over 1 billion tonnes of bulk ferro-alloys.

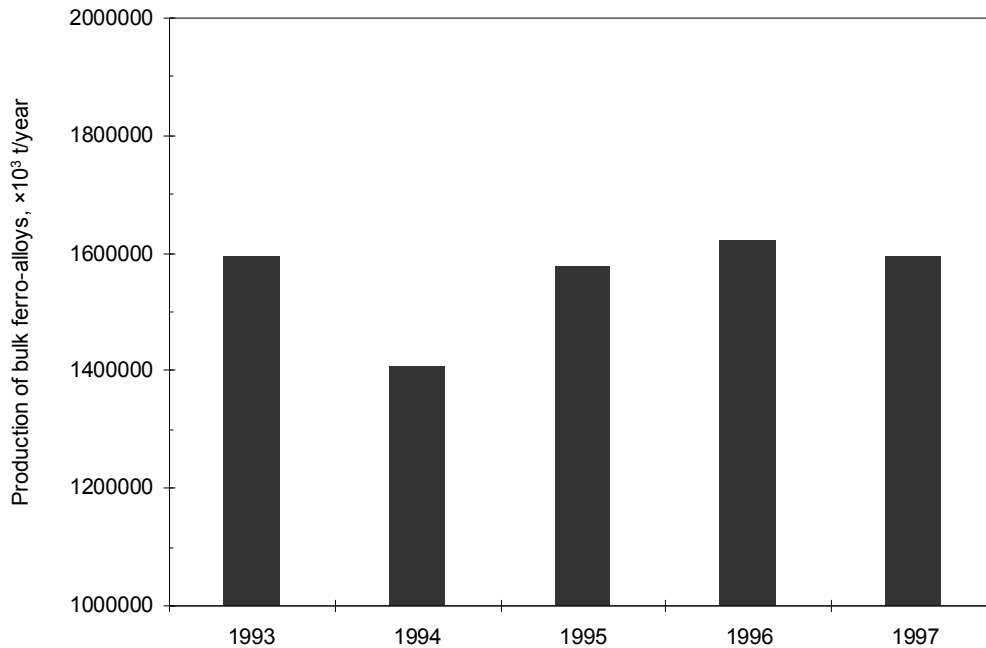

Figure 1.5. EU production of bulk ferro-alloys

Due to the technical development and metallurgical developments and changes in the iron and steel production also the consumption pattern of ferro-alloys has changed, especially in the industrialized countries: (i) a stagnant carbon steel production in increasingly produced in electric arc furnaces from scrap, which allow recovery of the alloying elements, reducing the relative consumption of ferro-alloys; (ii) a more efficient carbon steel production (e.g., continuous casting), from the view of low carbon emission. In the last 20 years, there has been noted a significant drop of the consumption of manganese (from 7 to 5 kg per tonne of steel) and of ferro-silicon (from 5 to 3.5 kg per tonne of steel); (iii) a growing need for metallurgically sophisticated alloying elements (e.g., niobium, molybdenum) and for treatment elements (e.g., calcium) led to an increased consumption of special alloys; (iv) an increasing production of stainless steel led to a significant increase of the consumption of chromium alloys, mainly high carbon ferro-chrome.

The consumption of ferro-alloys in Western Europe has varied around 4.2 Mt/year and production has reduced from 4 to 3 Mt over the last ten years.

At the European level there are about 60 industrial companies producing different ferro-alloys. The largest European ferro-alloy producing countries are Norway for the production of bulk ferro-alloys and France and Spain especially for the production of manganese- and silicon-alloys. Finland is a major producer of ferro-chrome from a local chrome ore mine. In Sweden mainly ferro-chrome and

ferro-silicon is produced. Special ferro-alloys (e.g., ferro-molybdenum, ferro-vanadium, ferro-titanium) are produced in the UK, Belgium, Austria and Germany.

The manufacturing of ferro-alloys is in general an energy consuming process, because the smelting takes place at high temperatures. The ferro-alloy production is related to a high consumption of raw materials such as ore, concentrates and fluxes as well as reductants and fuels like coke or coal and electrical energy.

Ferro-alloys are classified according to the carbon content: alloys with high-carbon (HC), medium-carbon (MC) and low-carbon (LC) content.

The specific consumption of raw materials and energy for the production of ferro-chrome is presented in Table 1.8.

Table 1.8. Specific consumption of raw materials and energy for the production of ferro-chrome

Raw material	HC FeCr	LC FeCr
Chromite, kg/t	2300-3000	1600
Reductant, kg/t	500-700	675 (FeSiCr)
Fluxes, kg/t	100-400	1100
Others, kg/t	8-25 (electrode) 0-300 (remelts)	<100 kg (sand) <40 kg (Si) 10 kg (electrode) 3 kg (boric acid)
Energy (electrical and thermal), kWh/t	6950-9890	3400

*\*no data available for MC FeCr*

The energy consumption used for sintering chromite ore depends on the type of sinter furnace that is used and on the characteristics of the different chromite concentrates. Coke breeze consumption will generally be in the range of 60-90 kg/t of sinter. With sinter consumption between 2 and 2.5 t/t of ferro-chrome, this equals to 120-225 kg of breeze/t of ferro-chrome. The external energy consumption of a steel belt sinter furnace ranges between 200-400 kWh/t pellets. The energy comes from coke breeze and CO-gas from smelting. The coke breeze consumption is 20-40 kg/t of pellets and the proportion of CO as external energy is about 20-40%.

The consumption of energy and raw material for the production of ferro-silicon and silicon metal is presented in Table 1.9.

Table 1.9. Specific consumption of raw material and energy by producing FeSi, Si and CaSi

Raw material	FeSi (75% Si)	Si-metal	CaSi
Quartzite, kg/t	1800	2600	1500
Reductant, kg/t	850	1150-1500	925
Electrode, kg/t	50	100	120
Iron ore pellets, kg/t	350	n.r.	n.r.
Limestone, kg/t	n.r.	n.r.	900
Woodchips, kg/t	0-400	1000-2000	n.r.
Energy (electrical and thermal), kWh/t	15045	20920-25200	16622

*\*n.r. - not relevant*

*\*\*The amount of electrical energy is due for a commonly used open or semi-closed submerged electric arc furnace without energy recovery*

The specific input factors for the production of the different sorts of ferro-manganese as well as for silico-manganese and the sinter process of manganese ores and concentrates are given in Table 1.10.

Table 1.10. Specific consumption for the production of manganese ore sinter, FeMn and SiMn

<b>Input</b>	<b>Sinter</b>	<b>HC FeMn</b>	<b>MC/LC FeMn</b>	<b>SiMn</b>
Ore, kg/t	1000-1300	1900-2100	1600-2000	500-1700
Coke, kg/t	100	410-450	200-300	400-600
Coal, kg/t	100	n.r.	n.r.	n.r.
Gas, m <sup>3</sup> /t	150-200	n.r.	-	n.r.
Electrode, kg/t	n.r.	8-20	6-8	20-30
Others, kg/t	n.r.	n.r.	800-1000 (fluxes) 700-1000 (SiMn)	400-2500 (FeMn slag)
Energy (electrical and thermal), kWh/t	n.r.	5357-6465	3140-4310	6880-10620

The consumption of raw material and energy for the production of various special ferro-alloys is presented in Table 1.11.

Table 1.11. Specific consumption for the production of special ferro-alloys

<b>Raw material</b>	<b>FeNi alloys</b>	<b>FeV</b>	<b>FeMo</b>	<b>FeTi</b>	<b>FeB</b>
Metal oxides, kg/t	n.a.	1100-2000	n.a.	n.a.	n.a.
Electric energy, kWh/t	1500	2200-2800	160-405	770	6000-11000
Gas, m <sup>3</sup> /t	120	n.r.	148-155 MJ/t	55	75
Quicklime, kg/t	n.a.	n.r.	20-180	n.r.	n.r.
Fluorspar, kg/t	n.r.	n.r.	0-30	n.r.	n.r.
Aluminium, kg/t	-	800-1000	36-70	n.r.	n.r.
Iron, kg/t	n.a.	100-150	23-210	-	n.a.
Others, kg/t	n.a.	n.a.	620-700 (FeSi)	-	n.a.

\*n.a. - data not available

Table 1.12 shows the amount of CO<sub>2</sub> released into the atmosphere as result of the production of bulk ferro-alloys.

Table 1.12. Emissions of CO<sub>2</sub> from the production of bulk ferro-alloys

<b>Bulk ferro-alloy</b>	<b>Emissions of CO<sub>2</sub>, kg/t</b>	
FeCr	HC FeCr	1200-2000
	MC/LC FeCr	110
FeSi		4240
Si-metal		6500
FeMn	HC FeMn	4000-4500 (BF) 1200-1500 (EAF)
	MC/LC FeMn	1560-2340
SiMn		1100-1800

### 1.2.2 Production of primary aluminium

Aluminium is a material with a large range of applications, in the transportation, construction and packaging industries, the electricity sector, in all high voltage electricity distribution systems, household appliances, and the mechanical and agricultural sectors. It is light, has good electrical conductivity and forms a surface oxide layer when exposed to air that prevents further corrosion. Aluminium is highly reactive particularly in the form of powder and is used in aluminothermic reactions to produce a variety of other metals [S1, E12].

The aluminium industry is the youngest and largest of the non-ferrous metal industries, aluminium smelting only began about a century ago. Total production of un-wrought metal amounted to 3.9 Mt in 1997 (43% of this output is accounted for by the processing of recycled scrap) while the production in 2008 amounted to 40 Mt. The production of primary aluminium in 2008 is shown in Figure 1.6, by country.

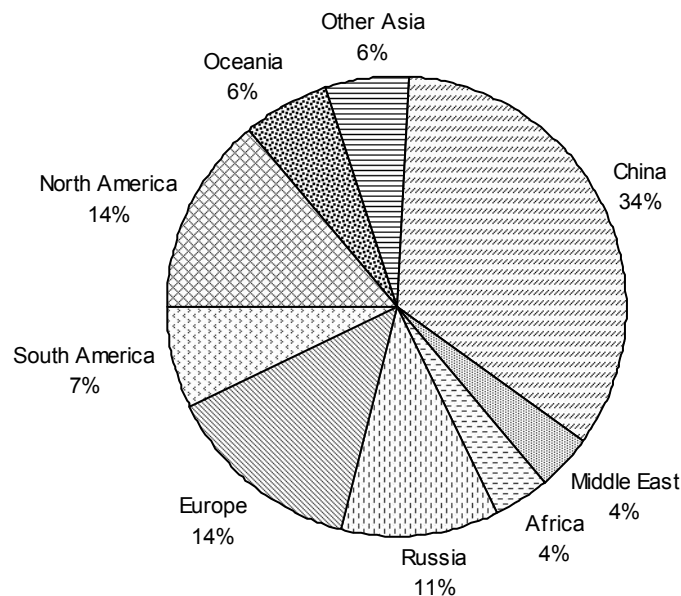

Figure 1.6. Production of primary aluminium in 2008

The European aluminium industry features mining and alumina production, primary and secondary smelting and metal processing into semi-finished products (e.g., bars, profiles, wires) or special products (e.g., powders, special alloys).

Many of these activities are integrated, but a number of European manufacturers focus their activity on one particular segment only, such as recycling and secondary smelting or semi-fabrication.

The EU accounted for 10% of the total world production in 1997, while in 2008 it was 14%. Norway and Germany are the largest producers of primary aluminium in Europe, followed by France, Spain and the UK.

Aluminium is produced from primary materials by the electrolytic reduction of aluminium oxide (alumina) dissolved in a molten bath of mainly sodium aluminium fluoride (cryolite) at a temperature of  $\sim 960^{\circ}\text{C}$ . From 100 t of bauxite can

be obtained up to 50 t of alumina, from which about 25 t of aluminium can be produced.

The overall process is standard for all sites and uses caustic soda to extract alumina from bauxite at elevated temperatures and pressures in digesters. Slurry is produced, which contains dissolved sodium aluminate and a mixture of metal oxides called red mud that is removed in thickeners. The aluminate solution is cooled and seeded with alumina to crystallise hydrated alumina. The crystals are washed and then calcined in rotary kilns or fluidized bed calciners before use or sale.

Primary aluminium is obtained exclusively by the Hall-Heroult electrolytic process. In this process, the electrolytic reduction cells are different both in shape and configuration of the graphite anode, as well as the feeding system with alumina differs. There are four types of technologies: side-worked prebaked anode cells; centre-worked prebaked anode cells; and, Soderberg cells.

The consumption of carbon anodes is approximately 0.4-0.45 t of carbon/t of aluminium produced, while the energy costs are about 30% of the production costs.

The production of alumina requires energy for calcinations and digestion, which is influenced mainly by the type of calciners used and by the origin and chemical composition of the bauxite. The quantities of sodium hydroxide and calcium oxide used are also linked to the composition of the bauxite. The amount of raw material used as well as the energy consumed for the production of alumina is shown in Table 1.13 [E12].

Table 1.13. Consumption of raw material and energy for the production of alumina

<b>Inputs (raw material/energy)</b>	<b>Quantity, kg/t of alumina</b>
Bauxite	1970-2250
NaOH (50%)	33-160
CaO	35-110
Water	1000-6000
Energy, GJ/t	8-13.5

The reduction of energy demand is mainly influenced by the use of tube digesters, which are able to operate at higher temperatures using a fused salt heat transfer medium. These plants have an energy consumption of <10 GJ/t.

The electrolysis stage has a high energy use ranging from 53 GJ/t for the best operated centre-worked prebaked anode cells to 61 GJ/t for some traditional Soderberg cells. The specific consumptions of this process are shown in Table 1.14 [E12].

Table 1.14. Consumption of raw material and energy in the process of electrolysis

<b>Inputs (raw material/energy)</b>	<b>Prebake cells</b>	<b>Soderberg cells</b>
Alumina, kg/t Al	1900-1940	1900-1940
Anodes, kg/t Al	400-440	500-580
AlF <sub>3</sub> , kg/t Al	15-25	15-25
Power for electrolysis, kWh/t Al	12.9-15.5	14.5-17
Rodding plant cast iron, kg/t Al	1-3	
Ramming and collar paste, kg/t Al	0-25	
Electrical power total, kWh/kg Al	14-16.5	15-18

The production of primary aluminium from recycled metal uses 5% less energy.

Emission sources within the process of primary aluminium production are: gases from calcining and heating for the production of alumina; process gases from anode baking; process gases from electrolytic cells; pot room ventilation; degassing and casting.

The potential releases from the electrolysis stage are: fluorides, tars, PFCs, PAHs, SO<sub>2</sub> and other sulfur compounds, dust, metal compounds, NO<sub>x</sub>, CO and CO<sub>2</sub>.

The conventional Soderberg electrode system has been improved in order to reduce anode effects and emissions from the pots to a level comparable with the total emission from prebaked pots, including anode baking. The main features are: automatic alumina point feeding and control of electrolysis; complete skirt coverage of bath crust; the use of "dry paste" with lower pitch content; improved burner for incineration of PAHs and other hydrocarbons in pot exhaust gas; complete hood coverage of the anode top, which is connected to a separate gas exhaust and dry alumina scrubber or dry anode top in combination with stud hole paste and increased anode height depending on effectiveness.

The production of primary aluminium results in emission of CO<sub>2</sub> as an inherent product of the electrolytic process (from carbon based anodes) and from the combustion of fuel to produce alumina and generation of electricity where this is based on fossil fuels.

In addition to this polyfluorinated carbons (PFCs) like CF<sub>6</sub> and C<sub>2</sub>F<sub>6</sub> are produced during the anode effect in the electrolysis cells. Both gases are powerful climate gases with 100 year GWP's of 6500 and 9200 respectively. In 1990, the total quantity of PFC gases emitted, calculated as CO<sub>2</sub>-eq, was about 15 Mt. The emission of PFC has been reduced over the past years from this sector due to the improvements in controlling the electrolysis process (reduction of the number of anode effects and the duration). In 2000, there were emitted about 6 Mt of PFC (as CO<sub>2</sub>-eq)

### **1.2.3 Production and processing of non-ferrous metals (including production of alloys, refining, foundry, casting)**

Lead is found in pure sulfide ores or nowadays more in mixed ores where it is associated with zinc and small amounts of silver and copper. Lead is a soft metal, having a low melting point and is resistant to corrosion. These properties give it great functional value, both in its pure form and in as alloys or compounds [E12].

Refined lead is derived from primary material in the form of lead ores and concentrates, and secondary material in the form of scrap and residue. Primary production requires the smelting of lead-bearing ores to produce lead bullion that is then refined. The economics of primary lead ore production is linked to the silver and zinc contents of the ore bodies. Lead metal production requires the sulfur content of the ores to be treated to produce sulfuric acid. Most primary lead smelters have a complex refining process associated with them and associated processes to recover the silver content as an Ag-Au alloy.

The secondary refining industry now supplies more than 50% of lead consumed. Lead acid accumulators in cars are the main source of scrap for secondary refining. The industry makes positive steps to encourage recycling of these batteries, this proportion is increasing as the world car population increases

and the return rate of old batteries increases. Secondary production may also require refining facilities if the secondary raw materials contain unwanted compounds.

In 1994 the production of lead in Europe was about 1.4 Mt, of which 52% was from secondary feed materials. In 2004 the secondary production at the European level was 87.2% from the total production of 1.87 Mt.

The largest producers of lead are China, Europe and the United States. In 2005, these regions together accounted for 73% of the global production of lead (35% China, 20% Europe and 18% the USA). Within the EU, the United Kingdom, Germany, France, Italy and Spain are the major producers and, on average, 49% of their output is based on secondary feed supplies.

Production of lead in Romania has slightly increased during the period 2001-2005, especially the production of secondary lead. In 2005, there were produced approximately 30 Mt of secondary lead and ~15 Mt of primary lead).

There are two basic processes available for the production of lead from lead sulfide or mixed lead and zinc sulfide concentrates: (i) sintering and smelting, which accounts for almost 78% of the primary lead production; or (ii) direct smelting.

#### **1.2.4 Manufacture of mineral wool insulation material using glass, rock or slag**

The mineral wool sector represents approximately 6-7% of the total output of the glass industry [E11]. Between 1986 and 1996 output grew only slowly from 1.4 to 2 Mt. The EU is dominated by five main producers: Saint-Gobain (20 installations in 12 Member States); Rockwool International (10 installations in 5 Member States); Partek Insulation (6 installations in 2 Member States); Pfeleiderer (3 installations in 2 Member States); and Owens Corning (4 installations in 2 Member States). Most of these companies have operations in non-EU countries or in other sectors. There are also several independent manufacturers in the EU. The number of installations producing mineral wool insulating materials in the EU Member States is shown in Figure 1.7 [E11].

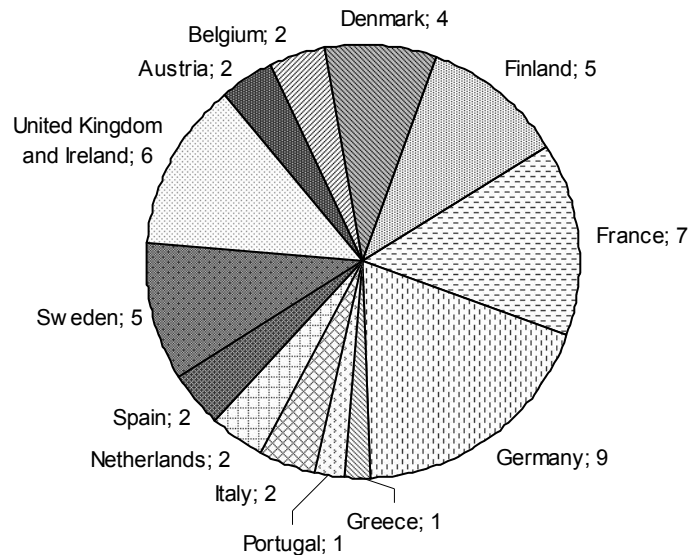

Figure 1.7. Number of mineral wool installations in EU

Glass wool furnaces are predominantly air-gas fired (usually with electric boost), but with a substantial number of electrically heated furnaces and a smaller number of oxy-gas fired furnaces. Stone wool furnaces are nearly all coke-fired cupolas with a few examples of gas fired or electrically heated furnaces.

For the production of mineral wool, the following raw materials and fuels are required, shown in Table 1.15. The consumption of energy during the production of glass and stone wool is indicated in Table 1.16.

Table 1.15. Raw materials/fuels used for the production of mineral wool

Type	Raw materials/fuels
Glass wool	Silica sand, process cullet, external cullet, process wastes, nepheline syenite, sodium carbonate, potassium carbonate, limestone, dolomite, sodium sulfate, borax, colemanite
Stone/slag wool	Basalt, limestone, dolomite, blast furnace slag, silica sands, sodium sulfate, process waste, occasionally wastes from other processes (e.g., foundry sand)
Fuels	Natural gas, electricity, coke (stone/slag wool only), back up fuels (light fuel oil, propane, butane)

Table 1.16. Total energy consumption for the production of mineral wool

	Glass wool	Stone/slag wool
Total energy consumption, GJ/t of finished product	11-22	7-18
Melting, % of total energy	20-45	30-70
Fiberising, % of total energy	25-35	25-35
Curing and drying, % of total energy	25-35	25-35
Others, % of total energy	6-10	6-10



The most used fuels in the melting process are natural gas for glass wool production and coke or natural gas for stone wool production. Natural gas is also used in substantial quantities for fiberising and curing, and electricity is used for general services.

The amount of CO<sub>2</sub> resulted from the production of mineral wool is shown in Table 1.17.

Table 1.17. CO<sub>2</sub> emissions from mineral wool melting/final processes

Processes	Emissions of CO <sub>2</sub> , kg/t of melt
<i>Emissions of CO<sub>2</sub> from melting processes</i>	
Electric melting glass wool	100-300
Flame fired furnaces glass wool	400-500
Combined fossil fuel/electrical melting	400-500
Cupola furnaces stone wool	400-800
Immersed electric arc furnace stone wool	20-200
Flame fired furnaces stone wool	400-500
<i>Emissions of CO<sub>2</sub> from final processes</i>	
Combined process (fiberising, forming and curing)	40-230
Product curing	40-230

### 1.2.5 Production of carbon black involving the carbonization of some organic substances (oils, tars, cracker and distillation residues)

About 65% of the world's consumption of carbon black is used in the production of tyres and tyre products for automobiles and other vehicles [E10]. Roughly 30% goes into other rubber products such as hose, belting, mechanical and moulded goods, footwear and other uses, with the remainder being used in plastics, printing ink, paint, paper and miscellaneous applications [E10].

As a member of the carbon family, carbon black differs from other carbon-based materials in many respects, with an important difference being that of bulk density. This property has prompted carbon black production facilities to be located as close as possible to consumers since, when compared with carbon black feedstock, the transportation costs for carbon black are considerably higher.

Figure 1.8 shows the carbon black capacity in Europe [E10].

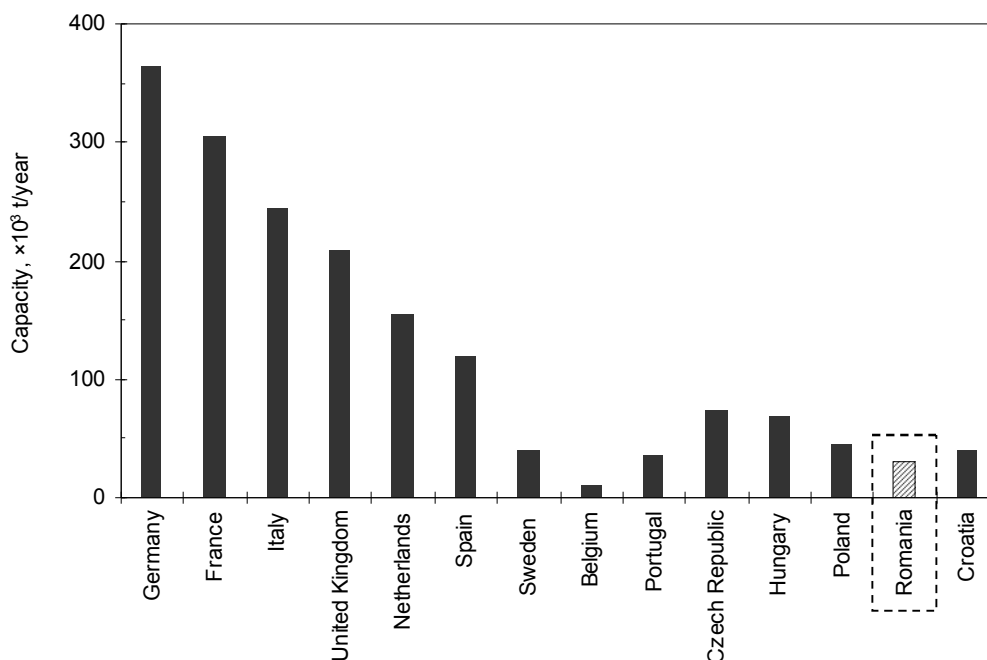

Figure 1.8. Production capacity of carbon black in Europe, in 2002

There is one facility in Romania for the production of carbon black, which is located in Pitesti with a capacity of 30 kt per year.

The energy consumption for the production processes of carbon black is difficult to make due to several reasons:

- it is unknown exactly which part of the feedstock is converted into product carbon black;
- energy recovery for internal and external use takes place in different forms (e.g., electricity and steam). Nearly all carbon black plants reuse a substantial part (15 to 30%) of the tail-gas in their dryers;
- feedstock and operating conditions are changed frequently, in order to produce different carbon black grades. Therefore, the energy content of the feedstock and the flow and calorific value of the tail-gas varies.

Table 1.18 shows the energy consumption and raw materials for the production of rubber black furnace [E10].

Table 1.18. Consumption of raw materials and energy

	<b>GJ/t of carbon black</b>
<i>Inflow</i>	
Primary feedstock	57.35-66.6
Secondary feedstock	11.1-14.8
Electrical energy	1.55-2.0
<i>Outflow</i>	
Product	33
Tail-gas	17-38
Other	12-27

### 1.2.6 Production of nitric acid

Depending on the application required, nitric acid is classified in (i) weak acid (50-65%), which is suitable for use in the production of fertilizers, and (ii) stronger acid (up to 99%) is required for many organic reactions [E9].

In 2003, the production of nitric acid in Europe was about 17 Mt. In the EU-25, Switzerland and Norway there were about 100 nitric acid plants in operation in 2006, having a production capacity of 150-2500 t/day. Germany, France, Belgium and the United Kingdom are the largest producers of nitric acid (>1.5 Mt/year) [E9].

The formation of nitric acid is exothermic and continuous cooling is needed within the absorber. As the conversion of NO to NO<sub>2</sub> is favoured by low temperature, this will be the significant reaction taking place until the gases leave the absorption column. An aqueous solution of nitric acid is withdrawn from the bottom of the absorption tower. The acid concentration can vary from 50 to 65% nitric acid, depending on the temperature, pressure, the number of absorption stages and the concentration of nitrogen oxides entering the absorber. The gases that are not absorbed in the nitric acid solution leave the absorption column at the top, at a temperature of approximately 20-30°C. This gas mixture is commonly referred to as tail gas and is heated by heat exchange. The hot tail gas is led through a NO<sub>x</sub> abatement system and through a tail gas expander for energy recovery.

The consumption of raw materials and energy for the production of HNO<sub>3</sub> is shown in Table 1.19 [E9].

Table 1.19. Consumption of raw materials and energy for the production of nitric acid

Process	Production technology		
	Mono Medium/Medium pressure nitric acid plants (M/M)	Mono High/High pressure nitric acid plants (H/H)	Dual Medium/High pressure nitric acid plants (M/H)
Pressure, bar	6	10	4.6/12
Ammonia, kg/t 100% HNO <sub>3</sub>	286	290	283
Electrical power, kWh/t 100% HNO <sub>3</sub>	9	13	8.5
Steam (saturated, 8 bar), t/t 100% HNO <sub>3</sub>	0.05	0.35	0.05
Excess steam (40 bar, 450°C), t/t 100% HNO <sub>3</sub>	0.75	0.58	0.65
Cooling water, t/t 100% HNO <sub>3</sub>	100	125	105

### 1.2.7 Production of ammonia

About 80% of the ammonia is currently used as the nitrogen source in fertilizers, with the other 20% being used in several industrial applications, such as the manufacture of plastics, fibres, explosives, hydrazine, amines, amides, nitriles and other organic nitrogen compounds which serve as intermediates in dyes and pharmaceuticals manufacturing [E9]. Among the important inorganic products manufactured from ammonia are nitric acid, urea and sodium cyanide.

In the EU, in 2001, there were produced approximately 11 Mt of ammonia, from around 50 plants, Figure 1.9 [E9].

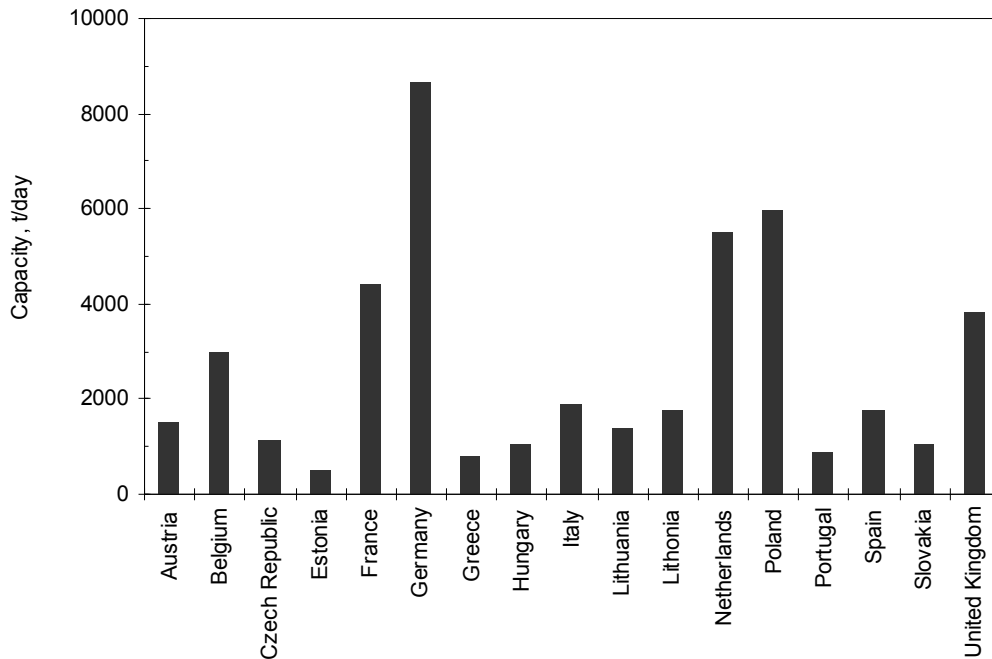

Figure 1.9. Ammonia production at the European level

A modern ammonia plant has a typical capacity of 1000-2000 t/day and new plants are commonly designed for up to 2200 t/day.

Ammonia is synthesized from nitrogen and hydrogen by the following reaction:



Depending of the type of fossil fuel, two different methods are mainly applied to produce the hydrogen for ammonia production: steam reforming or partial oxidation.

### 1.2.8 Production of soda ash and sodium bicarbonate

#### **Soda ash**

Soda ash is a fundamental raw material to the glass, detergent and chemical industries and, as such, is of strategic importance in the European and global manufacturing framework [E10].

In Europe, soda ash is almost entirely manufactured according to the Solvay process (the so-called ammonia soda process), using the locally available natural raw materials of salt brine and limestone. The production capacity is between 160 and 1200 kt/year.

The current European soda ash capacities amount to over 15 Mt/year, and of that in the EU-25 approximately 7.7 Mt/year.

Because of the large tonnage of production involved, the plants require large quantities of basic raw materials: limestone and sodium chloride brine, as well as energy, cooling water and ammonia.

In 2002, the production capacity of soda ash of different European countries is shown in Figure 1.10.

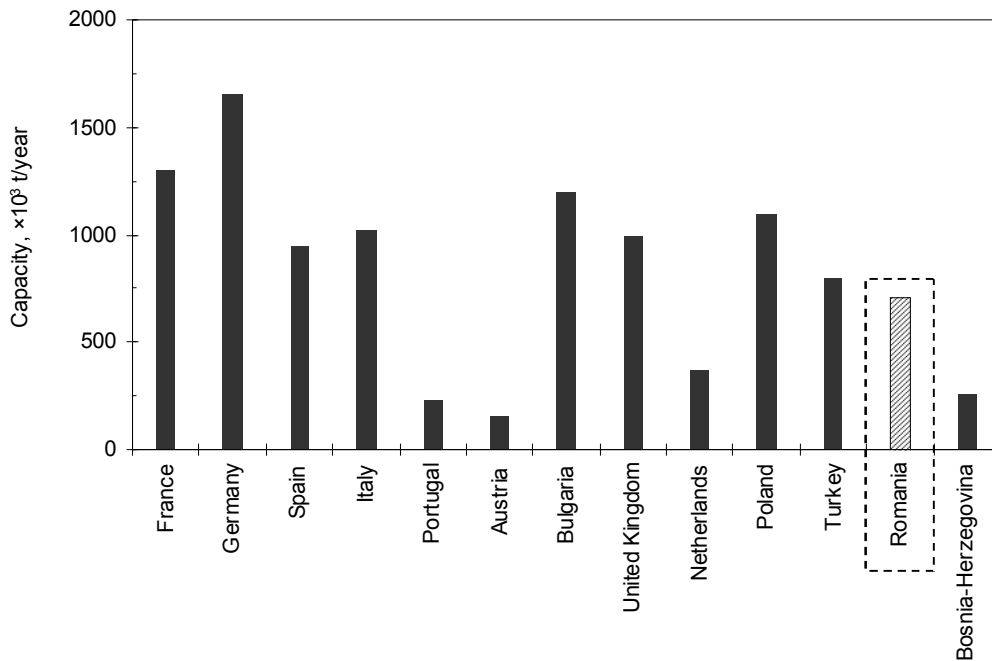
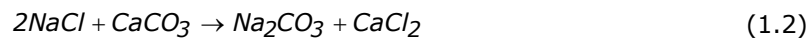

Figure 1.10. Production of soda ash in Europe, in 2002

In Romania there are two installations for the production of soda ash, in Govora (having a production capacity of 400 kt/year) and Ocna Muresului (310 kt/year) [E10].

The production of soda ash through the Solvay process is based on two main components: sodium chloride and calcium carbonate. The theoretical global reaction is:



In practice this direct way is not possible and it needs the participation of other substances and many different process steps to get the final product: soda ash. Chemical reactions relative to different steps of the process are as follows:

Absorption of ammonia:

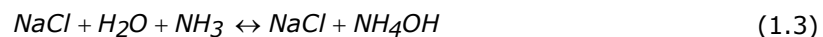

Formation of intermediate compounds:

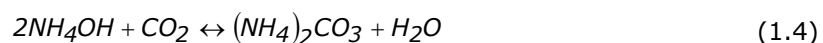

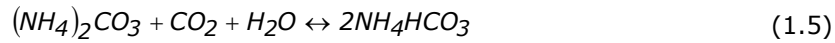

Formation of ammonium chloride:

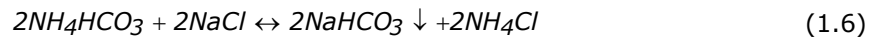

Thermal decomposition:

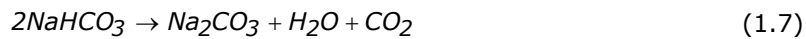

Recovery of free gaseous ammonia:

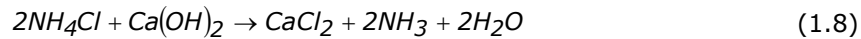

Limestone calcinations:



Hydration of calcium oxide:



Brine purification:



Table 1.20 presents the specific consumption of raw materials in a Solvay soda ash process and the emission level of CO<sub>2</sub> [E10].

Table 1.20. Consumption and emissions of the Solvay soda ash process

<b>Consumption/Emissions</b>	<b>Range</b>
<i>Raw materials, kg/t soda ash</i>	
Limestone	1050-1600 (inlet lime kiln) 1090-1820 (inlet plant)
Raw brine	NaCl (1530-1800) + Water (4500-5200)
NH <sub>3</sub>	0.8-2.1
<i>Energy, GJ/t soda ash (dense)</i>	
Fuels (lime kiln)	2.2-2.8
Fuels (soda ash), including electricity	7.5-10.8 0.18-0.47 (50-130 kWh/t soda ash)
<i>Emissions, kg/t soda ash</i>	
CO <sub>2</sub>	200-400

Steam is an important energy input into the manufacture of soda ash by the Solvay process both because of its mechanical capability (to drive a range of machinery including turbo-generators, gas compressors, vacuum machines, etc.) and as a thermal energy carrier for decomposition, distillation and drying.

The consumption of steam lies in the range of:

- for recovery of ammonia (depending on the process applied) – 1300 to 2400 kg/t soda ash;
- for decomposition of sodium bicarbonate – 1100 to 1300 kg/t soda ash;
- for drying of monohydrate (to obtain dense soda ash) – 350 to 450 kg/t soda ash.

During  $\text{CaCO}_3$  burning to  $\text{CaO}$  in the lime kilns,  $\text{CO}$  and  $\text{CO}_2$  are produced from the combustion of coke and decomposition of limestone. The Solvay process needs an excess of  $\text{CO}_2$  above that stoichiometrically required. Some of the excess is required to compensate for non-ideal absorption of  $\text{CO}_2$  in the carbonation towers.

The resulted  $\text{CO}_2$  may be beneficially used in the production of sodium bicarbonate or emitted to the atmosphere. The amount of  $\text{CO}_2$  vented to the atmosphere from a standalone soda ash process is in the range of 200 to 300 kg  $\text{CO}_2$ /t soda ash.

### **Sodium bicarbonate**

Sodium bicarbonate is produced in all major regions of the world and the worldwide capacity is estimated to be around 2.4 Mt/year. Figure 1.11 shows the European sodium bicarbonate capacity [E10].

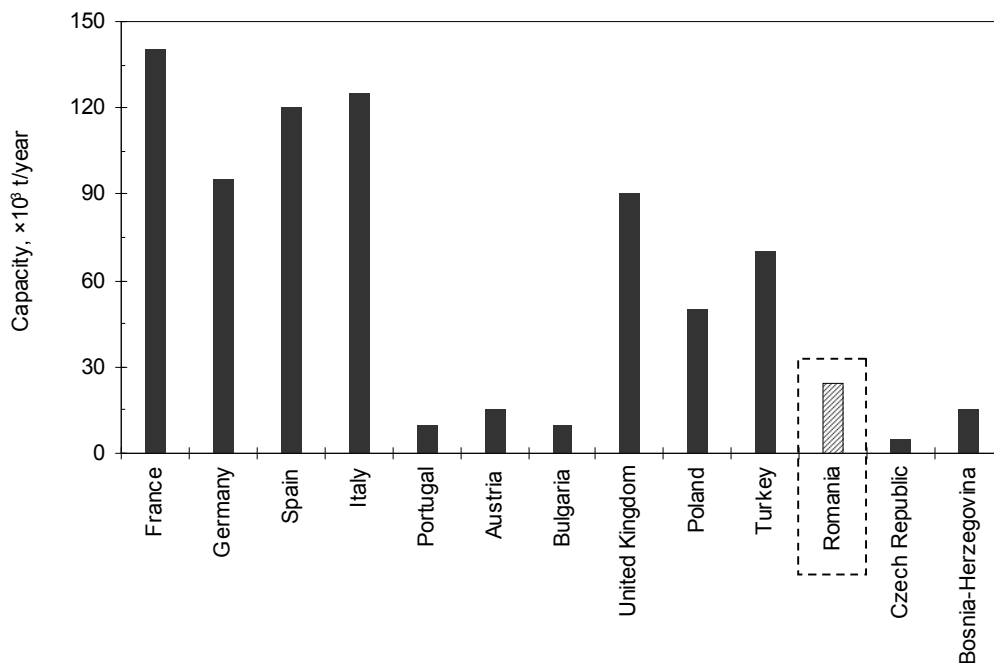
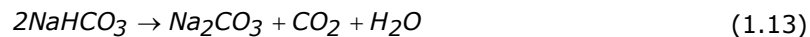

Figure 1.11. Production of sodium bicarbonate in Europe, in 2002

Sodium bicarbonate is mostly produced from a solution of sodium carbonate that may also contain small amounts of dissolved sodium bicarbonate. This solution can be prepared following two ways.

- dissolving soda ash in water;
- thermal decomposition of crude sodium bicarbonate from the filtration step of the soda ash process, after being suspended in a soda ash solution.

The thermal decomposition reaction is as follows:



The  $\text{CO}_2$  produced by this reaction is totally recovered in the soda ash process by mixing it with the outlet gas from the calcination of the crude sodium bicarbonate. The prepared in the sodium carbonate solution is sent to a bicarbonation tower where  $\text{CO}_2$  is blown until precipitation of sodium bicarbonate occurs.

The gaseous effluent from the bicarbonation columns contains some unconverted  $\text{CO}_2$  due to the equilibrium limit of the reaction. The quantity of  $\text{CO}_2$  in the gas released after bicarbonation is 130-290 kg/t sodium bicarbonate.

On average, some 550 kg 100%  $\text{CO}_2$  is used for the production of one tonne of  $\text{NaHCO}_3$ , of that 260 kg  $\text{CO}_2$  is captured by the product and 290 kg  $\text{CO}_2$  is released to the atmosphere.

The significant aspect of soda ash manufacture is its energy need in different forms: electrical, thermal and mechanical. Much attention has been paid, during the development of the process, to reduce energy consumption and to improve the transformation efficiency of the primary fuels involved, which have a positive impact on the environment through the reduction of fuel consumption and of the emissions of  $\text{CO}_2$ .

### 1.3 Aim of the study

Identifying the effects of applying the provisions of the EU "climate-energy" legislative package on industrial activities from point of view of environmental issues, associated costs and economic effects;

The research has been carried out on ten case studies relevant for the Romanian industrial sector.

### 1.4 Main objective

The main objective of this study is to generate a computational model, i.e. a comparative analysis tool of the impact generated by industrial activities on the environment and the possibilities to decrease it, in the current context of global commitment to reduce the emissions of GHG.

This model which might be extended at national level will enable the establishment of a coherent strategy for avoiding the effects induced by the application of the EU legislative package.



## 2 The EU climate-energy legislative package

In April 2009, the Council of the European Union adopted the climate-energy package containing measures to fight climate change and promote renewable energy. The package is designed to achieve the EU's overall environmental target of a 20% reduction in greenhouse gases and a 20% share of renewable energy in the EU's total energy consumption by 2020.

This package includes:

- Directive 2009/29/EC which improves and extends the greenhouse gas emission allowance trading scheme of the Community [E2];
- Decision No 406/2009/EC is about the effort of Member States to reduce their greenhouse gas emissions to meet the Community's greenhouse gas emission reduction commitments up to 2020 [E6];
- Directive 2009/28/EC is concerning the use of energy from renewable sources and their promotion [E4];
- Directive 2009/31/EC refers to the geological storage of carbon dioxide [E3].

Directive 2003/87/EC establishes a scheme for greenhouse gas emission allowance trading within the Community in order to promote reductions of greenhouse gas emissions in a cost-effective and economically efficient manner [E1]. In 2009, that Directive was amended by Directive 2009/29/EC which improves and extends the scheme for emission trading [E2].

The main objective of the United Nations Framework Convention on Climate Change is to stabilise the concentration of GHGs in the atmosphere at a level that would prevent dangerous anthropogenic interference with the climate system. In order to meet that objective, the overall global annual mean surface temperature increase should not exceed 2°C above pre-industrial levels [I1, I2]. The IPCC Assessment Report shows that in order to reach that objective, global emissions of GHG must peak by 2020. This implies the increasing of efforts by the Community, the quick involvement of developed countries and encouraging the participation of developing countries in the emission reduction process [I2].

In 2007, the European Council made a firm commitment to reduce the overall GHGs of the Community by at least 20% below 1990 levels by 2020, and by 30% provided that other developed countries commit themselves to comparable emission reductions and economically more advanced developing countries contribute adequately according to their responsibilities and respective capabilities.

By 2050, global greenhouse gas emissions should be reduced by at least 50% below their 1990 levels. All sectors of the economy should contribute to achieving these emission reductions, including international maritime shipping and aviation. Aviation is contributing to these reductions through its inclusion in the Community scheme.

The Community scheme should be extended to other installations the emissions of which are capable of being monitored, reported and verified with the same level of accuracy as that which applies under the monitoring, reporting and verification requirements currently applicable.

It is necessary that the definition of greenhouse gases should be aligned with the definition contained in the UNFCCC, and greater clarity should be given on the setting and updating of global warming potentials for individual greenhouse gases.

For small installations the emissions of which do not exceed a threshold of 25000 t CO<sub>2</sub>-eq/year, will be applied equivalent measures to reduce greenhouse gas emissions, in particular taxation. Member States should dispose a procedure to exclude such small installations from the ETS. For instance, hospitals may also be excluded if they undertake equivalent measures.

The following is added in Directive 2009/29/EC [E2]:

- *new entrant* means: (i) any installation carrying out one or more of the activities indicated in Annex I, which has obtained a greenhouse gas emissions permit for the first time after 30 June 2011; (ii) any installation carrying out an activity which is included in the Community scheme for the first time; or (iii) any installation carrying out one or more of the activities indicated in Annex I or an activity which is included in the Community scheme, which has had a significant extension after 30 June 2011, only in so far as this extension is concerned;
- *combustion* means any oxidation of fuels, regardless of the way in which the heat, electrical or mechanical energy produced by this process is used, and any other directly associated activities, including waste gas scrubbing;
- *electricity generator* means an installation that, on or after 1 January 2005, has produced electricity for sale to third parties, and in which no activity listed in Annex I is carried out other than the *combustion of fuels*.

These changes will take place from Phase III of the ETS which starts in 2013 for a period of eight years.

The Community-wide quantity of allowances should decrease in a linear manner calculated from the mid-point of the period from 2008 to 2012, ensuring that the emissions trading system delivers gradual and predictable reductions of emissions over time. The annual decrease of allowances should be equal to 1.74% of the allowances issued by Member States pursuant to Commission Decisions on Member States' NAPs for the period from 2008 to 2012.

On 9 July 2010, the European Commission published its decision on the Community-wide quantity of allowances for 2013. In accordance with it, for 2013 the total quantity of emission allowances is about 1.927 billion [E8].

Auctioning should be the basic principle for allocation of these allowances, as it is the simplest, and generally considered to be the most economically efficient system.

From 2013 onwards, Member States shall auction all allowances which are not allocated free of charge. By 31 December 2010, the Commission shall determine and publish the estimated amount of allowances to be auctioned.

The Commission shall adopt a regulation on timing, administration and other aspects of auctioning. After each auction, within one month, Member States shall report on the proper implementation of the auctioning rules, in particular with respect to fair and open access, transparency, price formation and technical and operational aspects.

In order to ensure an orderly functioning of the carbon and electricity markets, the auctioning of allowances for the period from 2013 onwards should start by 2011.

The total quantity of allowances to be auctioned by each Member State shall be composed as follows:

- 88% of the total quantity of allowances to be auctioned being distributed amongst Member States in shares that are identical to the share of verified emissions under the Community scheme for 2005 or the average of the period from 2005 to 2007, whichever one is the highest, of the Member State concerned (the year considered for Romania is 2007, being the first year with verified emissions);
- 10% of the total quantity of allowances to be auctioned being distributed amongst certain Member States for the purpose of solidarity and growth within the Community, thereby increasing the amount of allowances that those Member States auction;
- 2% of the total quantity of allowances to be auctioned being distributed amongst Member States the greenhouse gas emissions of which were, in 2005, at least 20% below their emissions in the base year applicable to them under the Kyoto Protocol.

It should be mentioned that Member States which did not participate in the Community scheme in 2005, their share shall be calculated using their verified emissions under the Community scheme in 2007.

Member States shall determine the use of revenues generated from the auctioning of allowances. However, at least 50% of the revenues should be used for one or more of the following: (i) to reduce greenhouse gas emissions, to adapt to the impacts of climate change and to fund research and development as well as demonstration projects for reducing emissions and for adaptation to climate change; (ii) to develop renewable energies to meet the commitment of the Community to using 20% renewable energies by 2020, as well as to develop other technologies contributing to the transition to a safe and sustainable low-carbon economy and to help meet the commitment of the Community to increase energy efficiency by 20% by 2020; (iii) measures to avoid deforestation and increase afforestation and reforestation in developing countries that have ratified the international agreement on climate change, to transfer technologies and to facilitate adaptation to the adverse effects of climate change in these countries; (iv) forestry sequestration in the Community; (v) the environmentally safe capture and geological storage of CO<sub>2</sub>, in particular from solid fossil fuel power stations and a range of industrial sectors and subsectors, including in third countries; (vi) to encourage a shift to low-emission and public forms of transport; (vii) to finance research and development in energy efficiency and clean technologies in the sectors covered by this Directive; (viii) measures intended to increase energy efficiency and insulation or to provide financial support in order to address social aspects in lower and middle income households; (ix) to cover administrative expenses of the management of the Community scheme.

All Member States will need to make substantial investments to reduce the carbon intensity of their economies by 2020 and those Member States where income per capita is still significantly below the Community average and the economies of which are in the process of catching up with the richer Member States will need to make a significant effort to improve energy efficiency.

For the power sector full auctioning should be the rule from 2013 onwards, taking into account its ability to pass on the increased cost of CO<sub>2</sub>, and no free allocation should be given for the capture and storage of CO<sub>2</sub> as the incentive for this arises from allowances not being required to be surrendered in respect of emissions which are stored.

In order to avoid distortions of competition, electricity generators may receive free allowances for district heating and cooling and for heating and cooling produced through high-efficiency cogeneration where such heat produced by installations in other sectors would be given free allocations.

The European Community will continue to take the lead in the negotiation of an ambitious international agreement on climate change that will achieve the objective of limiting global temperature increase to 2°C.

In the event that other developed countries and other major emitters of greenhouse gases do not participate in this international agreement, this could lead to an increase in GHGs in third countries where industry would not be subject to comparable carbon constraints (carbon leakage), and at the same time could put certain energy-intensive sectors and subsectors in the Community which are subject to international competition at an economic disadvantage.

To address the risk of carbon leakage, the Community should allocate 100% of allowances free of charge to sectors or subsectors meeting the relevant criteria. The definition of these sectors and subsectors and the measures required should be subject to reassessment to ensure that action is taken where necessary and to avoid overcompensation. For those specific sectors or subsectors where it can be duly substantiated that the risk of carbon leakage cannot be prevented otherwise, where electricity constitutes a high proportion of production costs and is produced efficiently, the action taken may take into account the electricity consumption in the production process, without changing the total quantity of allowances.

A sector or subsector shall be deemed to be exposed to a significant risk of carbon leakage if: (i) the sum of direct and indirect additional costs induced by the implementation of this Directive would lead to a substantial increase of production costs, calculated as a proportion of the gross value added, of at least 5%; and, (ii) the intensity of trade with third countries, defined as the ratio between the total value of exports to third countries plus the value of imports from third countries and the total market size for the Community (annual turnover plus total imports from third countries), is above 10%. Also, a sector or subsector is deemed to be exposed to a significant risk of carbon leakage if: (i) the sum of direct and indirect additional costs would lead to a particularly high increase of production costs of at least 30%; or, (ii) the intensity of trade with third countries, is above 30%.

Energy-intensive industries which are determined to be exposed to a significant risk of carbon leakage could receive a higher amount of free allocation or an effective carbon equalisation system could be introduced with a view to putting installations from the Community which are at significant risk of carbon leakage and those from third countries on a comparable footing.

The list of sectors and subsectors shall be determined after taking into account, where the relevant data are available, the following: (i) the extent to which third countries, representing a decisive share of global production of products in sectors or subsectors deemed to be at risk of carbon leakage, firmly commit to reducing greenhouse gas emissions in the relevant sectors or subsectors to an extent comparable to that of the Community and within the same time-frame; and (ii) the extent to which the carbon efficiency of installations located in these countries is comparable to that of the Community. This list may be supplemented after completion of a qualitative assessment, taking into account, the following criteria: (i) the extent to which it is possible for individual installations in the sector or subsector concerned to reduce emission levels or electricity consumption, including, as appropriate, the increase in production costs that the related investment may entail, for instance on the basis of the most efficient

techniques; (ii) current and projected market characteristics, including when trade exposure or direct and indirect cost increase rates are close to one of the thresholds mentioned in previous paragraph; (iii) profit margins as a potential indicator of long-run investment or relocation decisions.

Member States may also adopt financial measures in favour of sectors or subsectors determined to be exposed to a significant risk of carbon leakage, where such financial measures are in accordance with state aid rules applicable.

Those measures shall be based on ex-ante benchmarks of the indirect emissions of CO<sub>2</sub> per unit of production, which is calculated for a given sector or subsector as the product of the electricity consumption per unit of production corresponding to the most efficient available technologies and of the CO<sub>2</sub> emissions of the relevant European electricity production mix.

No free allocation shall be made in respect of any electricity production and electricity produced from waste gases.

Member States may give a transitional free allocation to installations for electricity production in operation by 31 December 2008 or to installations for electricity production for which the investment process was physically initiated by the same date, provided that one of the following conditions is met: (i) in 2007, the national electricity network was not directly or indirectly connected to the network interconnected system operated by the Union for the Coordination of Transmission of Electricity; (ii) in 2007, the national electricity network was only directly or indirectly connected to the network operated by UCTE through a single line with a capacity of less than 400 MW; or (iii) in 2006, more than 30% of electricity was produced from a single fossil fuel, and the GDP per capita at market price did not exceed 50% of the average GDP per capita at market price of the Community.

Each Member State concerned shall submit to the Commission a national plan that provides for investments in retrofitting and upgrading of the infrastructure and clean technologies, and diversification of their energy mix and sources of supply. Every year, a report on investments made shall be submitted to the Commission by the Member State concerned.

Also, no free allocation shall be given to electricity generators, to installations for the capture of CO<sub>2</sub>, to pipelines for transport of CO<sub>2</sub> or to CO<sub>2</sub> storage sites.

In respect of the production of heating or cooling, free allocation shall be given to district heating as well as to high efficiency cogeneration, as defined by Directive 2004/8/EC, for economically justifiable demand. In each year subsequent to 2013, the total allocation to such installations in respect to the production of that heat shall be adjusted by the linear factor mentioned above.

For each sector and subsector, in principle, the benchmark shall be calculated for products rather than for inputs, in order to maximise greenhouse gas emissions reductions and energy efficiency savings throughout each production process of the sector or the subsector concerned.

In defining the principles for setting ex-ante benchmarks in individual sectors or subsectors, the starting point shall be the average performance of the 10% most efficient installations in a sector or subsector in the Community in the years 2007-2008. The Commission shall consult the relevant stakeholders, including the sectors and subsectors concerned.

The amount of allowances allocated free of charge in 2013 to direct heating, including high efficiency cogeneration, shall be 80% of the quantity determined in accordance with the measures mentioned before. Thereafter the free allocation shall

decrease each year by equal amounts resulting in 30% free allocation in 2020, with a view to reaching no free allocation in 2027.

In 2013 and in each subsequent year up to 2020, installations in sectors and subsectors which are exposed to a significant risk of carbon leakage shall be allocated allowances free of charge at 100% of the quantity determined.

Free allocation to these installations will involve a greater reduction of the quantity of allowances available.

By 31 December 2009 and every five years thereafter, the Commission shall determine a list of the sectors or subsectors which are exposed to a significant risk of carbon leakage.

The Commission shall assess, at Community level, the extent to which it is possible for the sector or subsector concerned to pass on the direct cost of the required allowances and the indirect costs from higher electricity prices into product prices without significant loss of market share to less carbon efficient installations outside the Community.

These assessments shall be based on an average carbon price according to the Commission's impact assessment accompanying the package of implementation measures for the EU's objectives on climate change and renewable energy for 2020 and, if available, trade, production and value added data from the three most recent years for each sector or subsector.

Each Member State shall publish and submit to the Commission, by 30 September 2011, the list of installations covered by this Directive in its territory and any free allocation to each installation in its territory calculated in accordance with the rules. By 28 February of each year, the competent authorities shall issue the quantity of allowances that are to be allocated for that year.

In respect of installations which are excluded from the Community scheme, the Community-wide quantity of allowances to be issued from 1 January 2013 shall be adjusted downwards to reflect the average annual verified emissions of those installations in the period from 2008 to 2010, adjusted by the linear factor mentioned before.

Allowances issued from 1 January 2013 onwards are valid for emissions during periods of eight years beginning on 1 January 2013.

By 31 December 2011, the Commission shall adopt a regulation for the monitoring and reporting of emissions and, where relevant, activity data, from the activities listed in Annex I of this Directive, and shall specify the global warming potential of each greenhouse gas in the requirements for monitoring and reporting emissions for that gas.

The regulation takes into account the most accurate and up-to-date scientific evidence available, in particular from the IPCC, and may also specify requirements for operators to report on emissions associated with the production of goods produced by energy intensive industries which may be subject to international competition. That regulation may also specify requirements for this information to be verified independently.

Those requirements may include reporting on levels of emissions from electricity generation covered by the Community scheme associated with the production of such goods.

Also, by 31 December 2011, the Commission shall adopt a regulation for the verification of emission reports based on the principles set out in Annex V of this Directive and for the accreditation and supervision of verifiers. It shall specify conditions for the accreditation and withdrawal of accreditation, for mutual recognition and peer evaluation of accreditation bodies, as appropriate.

Member States and the Commission shall ensure that all decisions and reports relating to the quantity and allocation of allowances and to the monitoring, reporting and verification of emissions are immediately disclosed in an orderly manner ensuring non-discriminatory access. Information covered by professional secrecy may not be disclosed to any other person or authority except by virtue of the applicable laws, regulations or administrative provisions.

The excess emissions penalty relating to allowances issued by 1 January 2013 onwards shall increase in accordance with the European index of consumer prices.

New entrants, including new entrants in the period from 2008 to 2012 which received neither free allocation nor an entitlement to use certified emission reductions and emission reduction units in the period from 2008-2012, and new sectors shall be able to use credits up to an amount corresponding to a percentage, which shall not be set below 4.5%, of their verified emissions during the period from 2013 to 2020.

Up to 300 million allowances in the new entrants' reserve shall be available until 31 December 2015 to help stimulate the construction and operation of up to 12 commercial demonstration projects that aim at the environmentally safe capture and geological storage of CO<sub>2</sub> as well as demonstration projects of innovative renewable energy technologies, in the territory of the Union.

Following consultation with the operator, Member States may exclude from the Community scheme small installations which have reported to the competent authority emissions of less than 25000 t CO<sub>2-eq</sub> and, where they carry out combustion activities, have a rated thermal input below 35 MW, excluding emissions from biomass, in each of the three years preceding the notification.

## **3 Structure of production costs**

### **3.1 General aspects**

The analysis of production costs for industrial activities covered by the ETS, for those which will be covered (new ETS) as well as for those non ETS has been carried out by analyzing data from existing installations [E2]. Within each industrial activity, there exist installations which differ in several ways such as different installed capacity, production technology used, the composition of fuel and raw materials, unit's performance, production capacity, production costs, etc [R1, R2]. Moreover, there could be differences concerning the local market, management and policy of the company. Also, the current economic crisis has a negative impact on industrial activities, leading principally to decrease in production.

Generally, the impact of the ETS on installations depends on: (i) production process and associated costs, incorporating fixed and variable costs, also associated costs with ETS (administrative costs, direct and indirect impact of carbon price); (ii) nature of competition on the market.

### **3.2 Structure of production costs for industrial activities covered by the EU ETS**

For each industrial activity the structure of production costs varies depending on:

- Technological process;
- Consumption of fuel, raw materials and electricity.

Production costs for an industrial activity includes the following main categories of costs:

- Costs of fuels, raw materials and electricity;
- Costs of fixed assets;
- Costs with personnel;
- Administrative costs.

Taking into account the competition between different industrial activities, operators were asked for only to present info strictly necessary for this study. This work investigates mainly the impact of ETS on industrial activities as well as the measures to be taken in order to reduce this impact.

The operators were asked to give the following data concerning their production costs:

- Installed capacity;
- Installed capacity utilization factor;
- Annual production;
- Total production costs, specifying the following: (i) quantity of electricity purchased from the system and its cost; (ii) fuel consumption (type, quantity, cost); (iii) consumption of raw materials emitting CO<sub>2</sub> (type, quantity, cost);
- Operating profit margin.



The obtained data were generally for 2007 and/or 2008. Based on these data, for each representative installation, a simplified structure of unit costs of production for 2007 and/or 2008 was established.

### 3.2.1 Energy activities

The production costs and unit costs of production for representative installations of the following ETS sectors are further presented:

- Energy;
- Refinery.

#### **Energy sector**

There were analyzed two representative installations within the energy sector.

<b>Data for:</b>	Installation no. 1 (Energy sector)
<b>Type of production:</b>	Electricity production
<b>Fuels:</b>	Use of lignite (base fuel, 98%) in the production process and hydrocarbons (natural gas and oil, 2%)

The structure of the average unit production cost is shown in Figure 3.1.

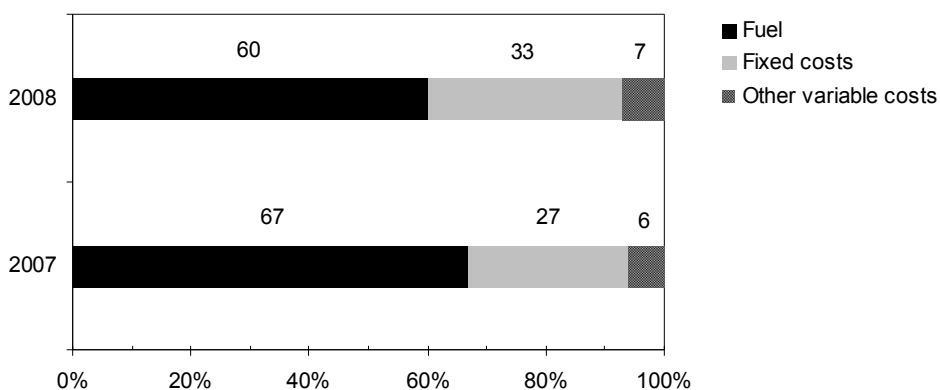

Figure 3.1. Structure of unit cost of production for 2007 and 2008 (Installation no. 1)

<b>Data for:</b>	Installation no. 2 (Energy sector)
<b>Type of production:</b>	Electricity and heat production
<b>Fuels:</b>	Use of lignite (base fuel, 94%) in the production process and hydrocarbons (oil, 6%)

The structure of the production costs of electricity is shown in Figure 3.2.

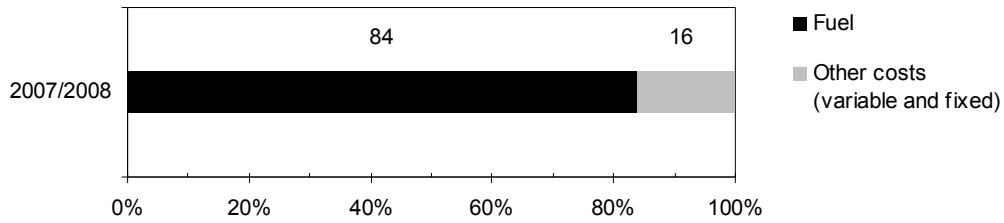

Figure 3.2. Structure of total annual production costs (Installation no. 2)

The structure of the unit costs of production for thermal energy and both for electrical and thermal energy is shown in Figure 3.3 and Figure 3.4, respectively.

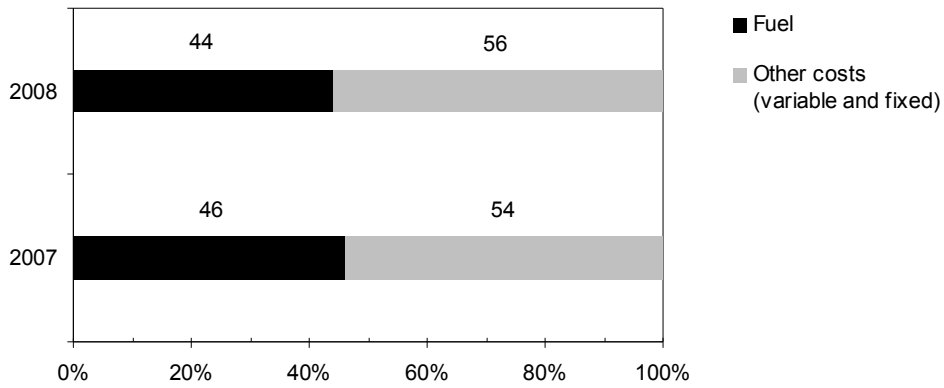

Figure 3.3. Structure of unit cost of production for thermal energy (Installation no. 2)

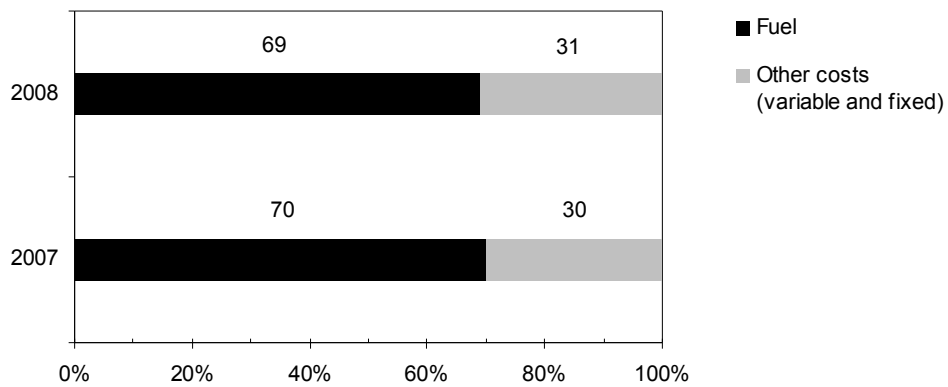

Figure 3.4. Structure of unit cost of production for electrical and thermal energy (Installation no. 2)

**Refinery sector**

<b>Data for:</b>	Installation no. 3 (Refinery sector)
<b>Type of production:</b>	Production of petroleum products through oil refinery. It includes the production of: liquefied petroleum gas, propane, petrol, diesel, petroleum coke, etc. Installation includes also a cogeneration plant that provides the necessary thermal energy and partly electrical energy.
<b>Fuels:</b>	<ul style="list-style-type: none"> <li>- natural gas</li> <li>- oil (resulting from technological process)</li> <li>- refinery gases (resulting from technological process)</li> </ul>
<b>Raw materials:</b>	<ul style="list-style-type: none"> <li>- oil</li> <li>- natural gas</li> </ul>

Figure 3.5 shows the structure of the average unit production cost for Installation no. 3.

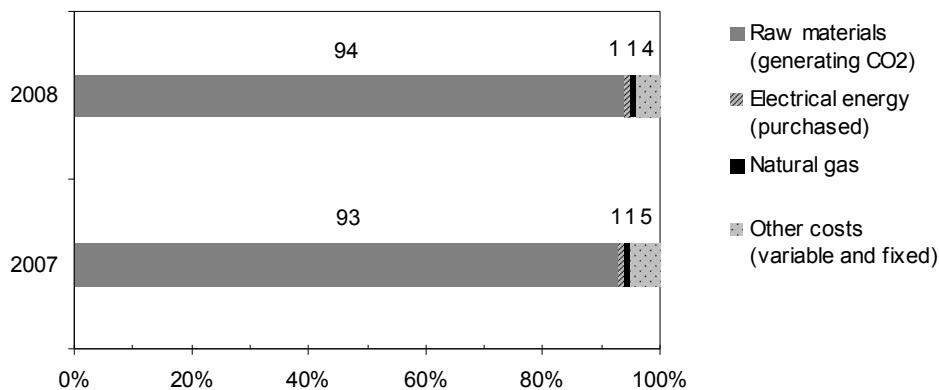

Figure 3.5. Structure of unit cost of production (Installation no. 3)

**3.2.2 Production and processing of ferrous metals**

<b>Data for:</b>	Installation no. 4 (Production and processing of ferrous metals)
<b>Type of production:</b>	Production and processing of ferrous metals
<b>Fuels:</b>	<ul style="list-style-type: none"> <li>- natural gas</li> </ul>
<b>Raw materials:</b>	<ul style="list-style-type: none"> <li>- limestone</li> <li>- ferro-alloys</li> <li>- petroleum coke</li> <li>- graphite electrodes</li> <li>- metal wastes</li> <li>- metal ore</li> </ul>

Figure 3.6 shows the structure of the average unit production cost for 2007, for Installation no. 4.

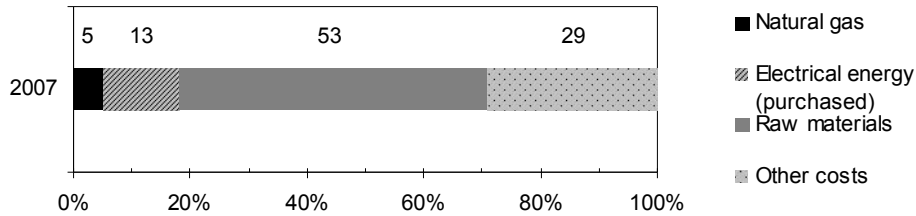

Figure 3.6. Structure of unit cost of production (Installation no. 4)

### 3.2.3 Mineral industry

The production costs for representative installations of the following ETS sectors are further presented:

- Cement;
- Lime;
- Glass;
- Ceramic.

#### **Cement sector**

<b>Data for:</b>	Installation no. 5 (Cement sector)
<b>Type of production:</b>	Production of cement clinker in rotary kilns. Industrial wastes and alternative fuels are partly used as substitutes for raw materials.
<b>Fuels:</b>	<ul style="list-style-type: none"> <li>- coal</li> <li>- petroleum coke</li> <li>- natural gas</li> <li>- oil</li> <li>- used tires, oils, plastics, mixed solid wastes (rubber), fossil wastes (petroleum residuum), biomass (paper, cardboard, wood, textiles)</li> </ul>
<b>Raw materials:</b>	<ul style="list-style-type: none"> <li>- gypsum, limestone, cement additives</li> <li>- granulated blast furnace slag, fly ash</li> </ul>

Figure 3.7 shows the structure of the average unit production cost for Installation no. 5.

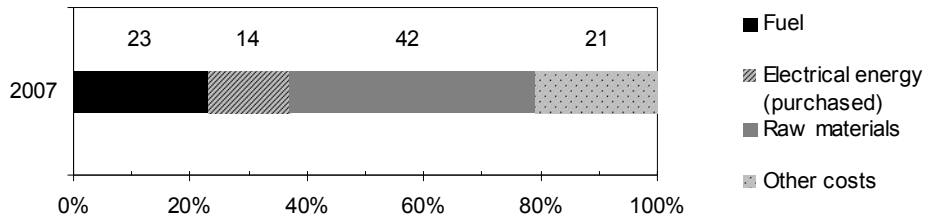

Figure 3.7. Structure of unit cost of production (Installation no. 5)

**Lime sector**

---

<b>Data for:</b>	Installation no. 6 (Lime sector)
<b>Type of production:</b>	Production of lime
<b>Fuels:</b>	- natural gas
<b>Raw materials:</b>	- limestone

---

The structure of the average unit production cost is shown in Figure 3.8.

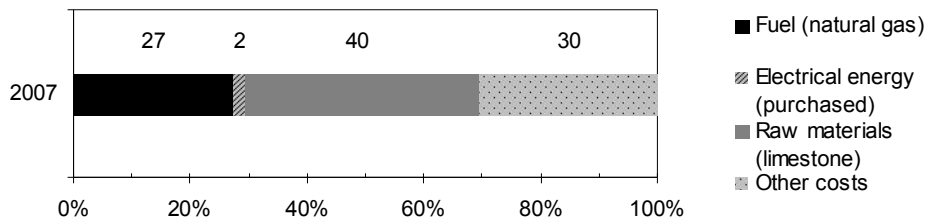

Figure 3.8. Structure of unit cost of production (Installation no. 6)

**Glass sector**

---

<b>Data for:</b>	Installation no. 7 (Glass sector)
<b>Type of production:</b>	Production of glass (including glass fibre)
<b>Fuels:</b>	- natural gas
<b>Raw materials:</b>	- limestone
	- soda ash
	- dolomite
	- graphite
	- charcoal
	- dolomitic lime

---

The structure of the average unit production cost is shown in Figure 3.9.

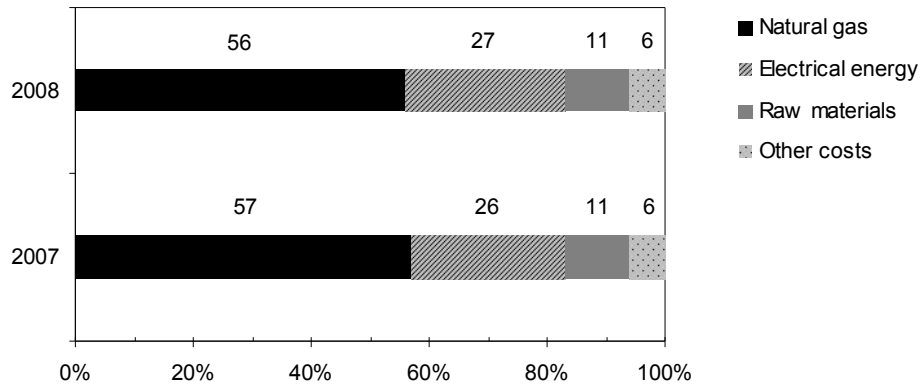

Figure 3.9. Structure of unit cost of production (Installation no. 7)

### Ceramic sector

---

<b>Data for:</b>	Installation no. 8 (Ceramic sector)
<b>Type of production:</b>	Manufacture of ceramic products
<b>Fuels:</b>	- natural gas
<b>Raw materials:</b>	- chalk - marble - dolomite

---

The structure of the average unit production cost is shown in Figure 3.10.

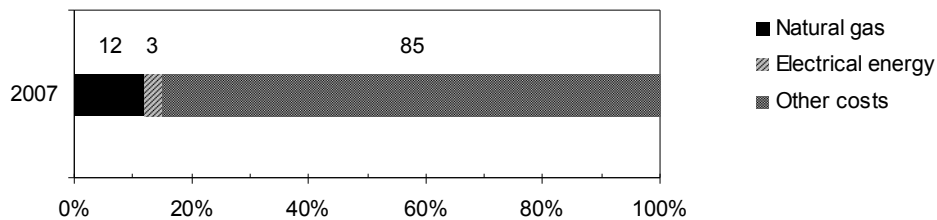

Figure 3.10. Structure of unit cost of production (Installation no. 8)

### 3.2.4 Pulp and paper sector

---

<b>Data for:</b>	Installation no. 9 (Pulp and paper sector)
<b>Type of production:</b>	Production of paper, cardboard, etc.
<b>Fuels:</b>	- oil - diesel - wood - sawdust
<b>Raw materials:</b>	- sodium carbonate ( $\text{Na}_2\text{CO}_3$ )

---

The following structure of the average unit production cost for the pulp and paper sector, for 2007, is shown in Figure 3.11.

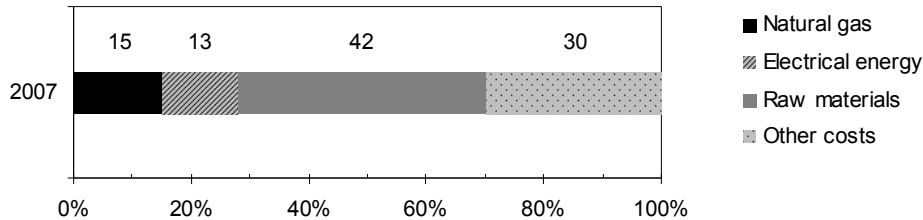

Figure 3.11. Structure of unit cost of production (Installation no. 9)

It can be noted from the analysis above (Installations no. 1-9) that the share of fuel in the energy sector is the largest while in industrial sectors the raw materials have a higher share than fuel. Except for glass sector (Installation no. 7) where due to the technological process the fuel used has an important share (>50%).

### 3.3 Structure of production activities that will be covered by the EU ETS for the period 2013-2020

#### 3.3.1 Energy and lime sector

This installation represents an existing activity within the trading scheme for the period 2008-2012, being a part of two sectors, namely energy and lime. From 2013 onwards it will represent a new ETS installation with other emission sources from chemical industry (taking into account the new climate-energy package).

<b>Data for:</b>	Installation no. 10 (Energy and lime sector)
<b>Type of production:</b>	Production of bulk organic chemicals, pesticides and agrochemical products
<b>Fuels:</b>	- natural gas
<b>Raw materials:</b>	- soda (block, flakes, pearls)
	- octanol
	- vinyl chloride

The structure of the unit cost of production for 2007 is shown in Figure 3.12.

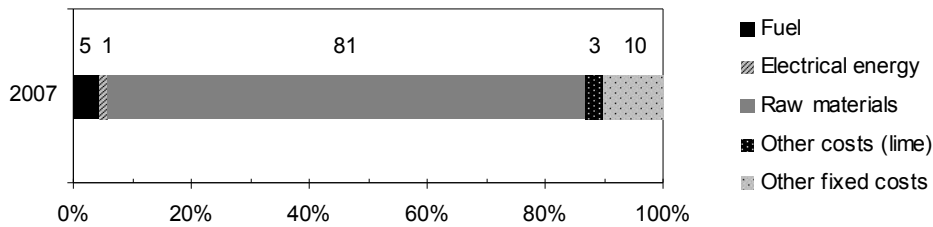

Figure 3.12. Structure of unit cost of production (Installation no. 10)

### 3.3.2 Existing ETS activity to which after 2012 will be added a new ETS activity with other emission sources

<b>Data for:</b>	Installation no. 11 (Energy sector, current ETS)
<b>Type of production:</b>	Production of basic organic chemicals (e.g., melamine), inorganic chemicals (e.g., ammonia) as well as the production of fertilizers (e.g., potassium- or phosphorus-based)
<b>Fuels:</b>	- natural gas
<b>Raw materials:</b>	- combustion air - de-mineralized water - process air - process steam - steam for stripping ammonia condensate - process condensate

The structure of the average unit production cost, using data for 2007, is shown in Figure 3.13.

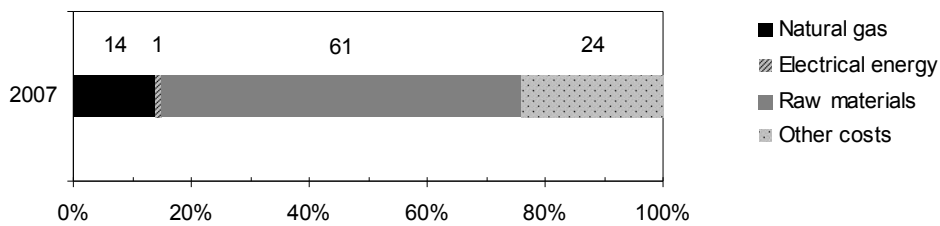

Figure 3.13. Structure of unit cost of production (Installation no. 11)



### 3.4 Structure of production costs for non ETS production activities

#### 3.4.1 Existing ETS activity for 2008-2012, which from 2013 onwards becomes non ETS

This installation represents an existing ETS activity for the period 2008-2012, being currently a part of the energy sector. From 2013 onwards it becomes an installation non ETS.

---

<b>Data for:</b>	Installation no. 12 (non ETS)
<b>Type of production:</b>	Products for automotive industry
<b>Fuels:</b>	- natural gas - liquefied petroleum gas - oil
<b>Raw materials:</b>	- natural gas - liquefied petroleum gas - oil - diesel - gasoline

---

The structure of the unit cost of production, using data for 2007, is shown in Figure 3.14.

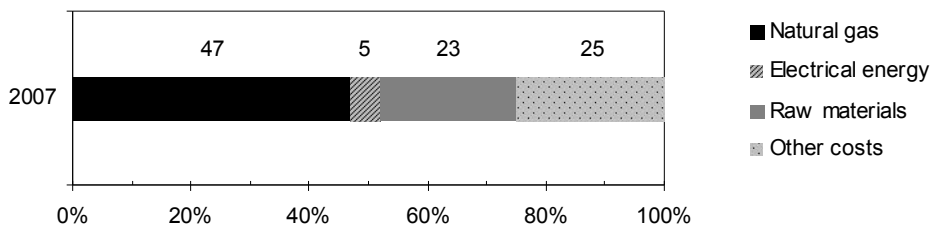

Figure 3.14. Structure of unit cost of production (Installation no. 12)

#### 3.4.2 Non ETS activity that becomes after 2012 a new ETS

This installation represents a non ETS activity for the period 2008-2012, which becomes ETS after 2013.

---

<b>Data for:</b>	Installation no. 13 (new ETS after 2013)
<b>Type of production:</b>	Production of lead
<b>Fuels:</b>	- coke - natural gas
<b>Raw materials:</b>	- limestone

---

The production costs for this category were estimated because the chosen operator did not provide with necessary data for this study.

The structure of the unit cost of production is shown in Figure 3.15.

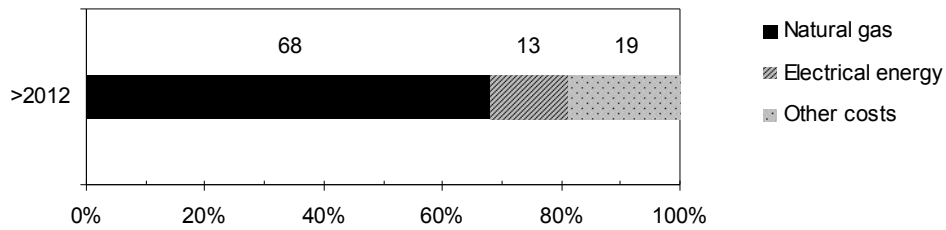

Figure 3.15. Structure of unit cost of production (Installation no. 13)

For analyzed installations above (existing ETS, new ETS and non ETS), for 2013, the current structure of costs was presented in a simplified manner, namely input costs (fuel, raw materials, electricity).

It should be mentioned that operators did not provide any data concerning the costs of participation on the carbon market.

## **4 ETS cost impacts on production costs for representative installations in 2013**

For 2013, for all representative installations, the analysis is carried out within the following assumptions:

- Costs to be involved in monitoring, reporting and verifying CO<sub>2</sub> emissions are considered to remain virtually constant with those from the period 2008-2012, having a very low share of production costs;
- Costs of purchasing and trading of emission allowances are calculated in the following situations: (i) allowance price: 15-40 € per allowance; (ii) trading price: 0.01 € per allowance.

### **4.1 Presentation of case studies**

To determine the additional costs for 2013, there have been analyzed responses to questionnaires, which were sent to industrial operators who agreed to collaborate in order to develop this study. Data sent by them were very brief, incomplete and often inconclusive so that the scenarios developed within this study take into account both the information obtained and documentation accomplished during the work study. There were also taken into account the provisions of Romania's NAP [R6], the current economic crisis, a possible increase or decrease of annual production in different industrial sectors, as well as the evolution of allowance price.

The basic principles taken into account in estimating case studies are as follows:

- Basic case study, according which the growth of average annual production corresponds to the estimations provided by responses to questionnaires or the trends estimated in Romania's NAP, into two allowance price options: (i) 15, 20, 25 €; and, (ii) 30, 35, 40 €;
- Case study with growth zero, according which the average annual production for the period 2008-2012 will not increase compared to 2007 or 2008, due to the current economical and social conditions, into two allowance price options: (i) 15, 20, 25 €; and, (ii) 30, 35, 40 €;
- Case study with 10% increase or decrease of the average annual production for the period 2008-2012 compared to 2007, into two allowance price options: (i) 15, 20, 25 €; and, (ii) 30, 35, 40 €;

Each of these case studies has been analyzed separately for the allowance price presented, resulting in a total of six case studies for 2013. It should be also mentioned that the trend of electricity purchased and the behavior of CO<sub>2</sub> emissions is similar to the evolution of average annual production for 2013, for each case study analyzed.

Table 4.1 presents the way of estimation of average annual production, electricity purchased and emissions of CO<sub>2</sub> for each case study, for 2013.

Table 4.1. Presentation of different case studies with different allowance price

Installation	Sector	Case study 0 Increase according to NAP	Case study 1 Increase 0 in comparison to 2007	Case study 2 Increase or decrease 10% in comparison to 2007	Case study 3 Increase according to NAP	Case study 4 Increase 0 in comparison to 2007	Case study 5 Increase or decrease 10% in comparison to 2007
		Allowance price, €					
		15, 20, 25	15, 20, 25	15, 20, 25	30, 35, 40	30, 35, 40	30, 35, 40
No. 1	Energy	According to the increase of production based on coal for 2008-2012 from NAP (1.035*val 2007)	Increase 0 compared to 2007	Increase by 10% compared to 2007	According to the increase of production based on coal for 2008-2012 from NAP (1.035*val 2007)	Increase 0 compared to 2007	Increase by 10% compared to 2007
No. 2	Energy	According to the increase of production based on coal for 2008-2012 from NAP (1.035*val 2007)	Increase 0 compared to 2007	Increase by 10% compared to 2007	According to the increase of production based on coal for 2008-2012 from NAP (1.035*val 2007)	Increase 0 compared to 2007	Increase by 10% compared to 2007
No. 3	Energy	Increase of production by 25% compared to 2007 (according to address 2009)	Increase 0 compared to 2007	Increase by 10% compared to 2007	Increase of production by 25% compared to 2007 (according to address 2009)	Increase 0 compared to 2007	Increase by 10% compared to 2007

Table 4.1 (continued)

No. 4	Ferrous metals	Increase of production by 11.28% compared to 2007 (sf NAP)	Increase 0 compared to 2007	Decrease by 10% compared to 2007	Increase of production by 11.28% compared to 2007 (sf NAP)	Increase 0 compared to 2007	Decrease by 10% compared to 2007
No. 5	Cement	Increase of production by 50.47% compared to 2007 (sf NAP)	Increase 0 compared to 2007	Increase by 10% compared to 2007	Increase of production by 50.47% compared to 2007 (sf NAP)	Increase 0 compared to 2007	Increase by 10% compared to 2007
No. 6	Lime	Increase of production by 22.29% compared to 2007 (sf NAP)	Increase 0 compared to 2007	Increase by 10% compared to 2007	Increase of production by 50.47% compared to 2007 (sf NAP)	Increase 0 compared to 2007	Increase by 10% compared to 2007
No. 7	Glass	Increase of production by 13.75% compared to 2007 (sf NAP)	Increase 0 compared to 2007	Decrease by 10% compared to 2007	Increase of production by 22.29% compared to 2007 (sf NAP)	Increase 0 compared to 2007	Decrease by 10% compared to 2007
No. 8	Ceramic	Increase of production by 19.58% compared to 2007 (sf NAP)	Increase 0 compared to 2007	Decrease by 10% compared to 2007	Increase of production by 19.58% compared to 2007 (sf NAP)	Increase 0 compared to 2007	Decrease by 10% compared to 2007
No. 9	Pulp and paper	Increase of production by 29.9% compared to 2007 (sf NAP)	Increase 0 compared to 2007	Decrease by 10% compared to 2007	Increase of production by 29.9% compared to 2007 (sf NAP)	Increase 0 compared to 2007	Decrease by 10% compared to 2007

Table 4.1 (continued)

No. 10	Energy and lime	Increase of production by 39% compared to 2007 (sf NAP)	Increase 0 compared to 2007	Decrease by 10% compared to 2007	Increase of production by 39% compared to 2007 (sf NAP)	Increase 0 compared to 2007	Decrease by 10% compared to 2007
No. 11	Energy and new-ETS (after 2012)	-	Increase 0 compared to 2007	-	-	Increase 0 compared to 2007	-
No. 12	Non-ETS (after 2012)	-	-	-	-	-	-
No. 13	New-ETS (after 2012)	-	Increase 0 compared to 2007	-	-	Increase 0 compared to 2007	-

## 4.2 Impact of acquisition and transaction costs of allowances on current production costs for representative installations

This chapter presents the impact of acquisition and transaction costs of certificates for each representative installation for 2013, taking into account: (i) the percentage not allocation of each installation; (ii) different prices of certificates; as well as (iii) the increase of electricity costs after 2012.

Calculations have been performed within the following assumptions:

- 2013 is the first year in which the new legislative package on climate change enters into the force;
- Selected installations for existing and new ETS industrial sectors are those presented and analyzed in previous chapters, being the only ones which accepted to collaborate and provide us with data necessary for calculations;
- For 2013 the industrial production, costs and revenues are considered the same as those for the period 2008-2012. Case studies of calculation were presented previously (this assumption was considered because industrial operators who responded to the questionnaire did overestimated the indicators);
- Allocation of the greenhouse gas emission certificates: there have been considered the levels of allocation deficit of 5-40%;
- Price of the greenhouse gas emission certificates: for 2013, it is considered a price ranging between 15 and 40 €/certificate;
- Profit taken into consideration is identical to that used in Chapter 4.1., being communicated through the questionnaires;
- In order to set the ceiling for 2013 and the share of emission allowances that will be freely available for industrial sectors, both Directive 2009/29/EC [E2] and the draft of European Commission that contains a list of industrial sectors and subsectors [E7], which are exposed to a significant risk of carbon leakage were taken into account;

According to Directive 2009/29/EC for the 2013-2020 trading period the European Commission has committed to reduce the emissions of greenhouse gases by 20%, compared with 1990 levels, by 2020 [E2].

The amount of emission allowances to be issued for 2013 is reduced by the linear reduction factor of 1.74% of the average annual total amount of allowances which were allocated in 2008-2012 through Member States' NAPs.

Unlike the current situation, when the allocation of emission allowances is free of charge, the producers of electrical energy will have to pay for these allowances from State's authorities. Therefore, this cost will be reflected in a higher cost of electricity to the final consumer (domestic or industrial).

Also, industrial sectors such as cement production, steel, aluminium, etc., will be faced with an increase in energy prices and production costs, losing in this way a competitive advantage over similar producers, which have locations in countries outside the European Union. This might lead the European producers to move to other countries, thus affecting the economy of EU as well as the standard of living of EU citizens.

Only the installations with best performance will receive the emission allowances free of charge proportional to the level of reference of the best available technology. Therefore, the installations which do not meet this criterion will have to

pay for the greenhouse gas emission allowances, which will be auctioned by State's authorities.

Taking into consideration that installations from Romania's industrial sector have relatively low performance, the emission allowances which are not allocated will be greater and different for each sector. That is why the calculation has been carried out for values ranging between 5 and 40%.

These values depend on: (i) the total number of emission allowances to be allocated in 2013 (lower by 1.74% per year in comparison to the mid-point of the 2008-2012 period); (ii) the cost of electricity purchased; (iii) the profit; and (iv) the allowance price.

Table 4.2 shows the share of additional costs for purchasing and trading due to the application of the greenhouse gas emission allowance trading scheme. Each sector has been analyzed, having six case studies, different allowance price and different quantity of allowances which are not allocated.



Table 4.2. Share of additional costs for purchasing and trading of allowances, due to the application of the greenhouse gas emission trading scheme

Sector		Percentage (not allocated), %							
		5	10	15	20	25	30	35	40
<i>Energy (Power Plants)</i>									
<b>Impact of costs for purchasing and trading of allowances, %</b>									
15 €/certificate	0	1.89	3.98	6.32	8.96	11.94	15.36	19.29	23.89
20 €/certificate		2.51	5.31	8.43	11.94	15.92	20.47	25.72	31.84
25 €/certificate		3.14	6.63	10.53	14.92	19.90	25.58	32.14	39.79
15 €/certificate	1	1.95	4.12	6.54	9.27	12.36	15.89	19.97	24.72
20 €/certificate		2.60	5.49	8.72	12.36	16.48	21.19	26.62	32.96
25 €/certificate		3.25	6.86	10.90	15.44	20.59	26.48	33.27	41.19
15 €/certificate	2	1.77	3.75	5.95	8.43	11.24	14.45	18.15	22.48
20 €/certificate		2.37	4.99	7.93	11.23	14.98	19.26	24.20	29.96
25 €/certificate		2.96	6.24	9.91	14.04	18.72	24.07	30.24	37.44
30 €/certificate	3	3.77	7.96	12.64	17.90	23.87	30.69	38.56	47.75
35 €/certificate		4.40	9.28	14.74	20.89	27.85	35.81	44.99	55.70
40 €/certificate		5.02	10.61	16.85	23.87	31.82	40.92	51.41	63.65
30 €/certificate	4	3.90	8.24	13.08	18.53	24.71	31.77	39.91	49.42
35 €/certificate		4.55	9.61	15.26	21.62	28.82	37.06	46.56	57.65
40 €/certificate		5.20	10.98	17.44	24.70	32.94	42.35	53.21	65.88
30 €/certificate	5	3.55	7.49	11.89	16.85	22.46	28.88	36.28	44.92
35 €/certificate		4.14	8.73	13.87	19.65	26.20	33.69	42.33	52.41
40 €/certificate		4.73	9.98	15.85	22.46	29.94	38.50	48.37	59.89
<i>Energy (Power Plants) – electrical energy</i>									
<b>Impact of costs for purchasing and trading of allowances, %</b>									
15 €/certificate	0	1.32	2.78	4.41	6.25	8.34	10.72	13.46	16.67
20 €/certificate		1.75	3.70	5.88	8.33	11.11	14.28	17.95	22.22
25 €/certificate		2.19	4.63	7.35	10.41	13.88	17.85	22.43	27.77
15 €/certificate	1	1.40	2.90	4.60	6.50	8.60	11.10	13.90	17.30
20 €/certificate		1.80	3.80	6.10	8.60	11.10	14.80	18.60	23.00
25 €/certificate		2.30	4.80	7.60	10.80	14.40	18.50	23.20	28.70

Table 4.2 (continued)

15 €/certificate		1.24	2.61	4.15	5.88	7.84	10.08	12.67	15.69
20 €/certificate	2	1.65	3.48	5.53	7.84	10.45	13.44	16.89	20.91
25 €/certificate		2.06	4.35	6.92	9.80	13.06	16.80	21.10	26.13
30 €/certificate		2.63	5.55	8.82	12.49	16.66	21.42	26.91	33.32
35 €/certificate	3	3.07	6.48	10.29	14.58	19.43	24.99	31.39	38.87
40 €/certificate		3.51	7.40	11.76	16.66	22.21	28.55	35.88	44.42
30 €/certificate		2.73	5.75	9.13	12.93	17.24	22.17	27.85	34.48
35 €/certificate	4	3.18	6.70	10.65	15.09	20.11	25.86	32.49	40.23
40 €/certificate		3.63	7.66	12.17	17.24	22.99	29.55	37.13	45.97
30 €/certificate		2.48	5.22	8.30	11.76	15.67	20.15	25.32	31.35
35 €/certificate	5	2.89	6.10	9.68	13.71	18.29	23.51	29.54	36.57
40 €/certificate		3.30	6.97	11.06	15.67	20.90	26.87	33.76	41.79
<i>Energy (Power Plants) – thermal energy</i>									
<b>Impact of costs for purchasing and trading of allowances, %</b>									
15 €/certificate		1.29	2.71	4.30	6.09	8.13	10.45	13.13	16.25
20 €/certificate	0	1.71	3.61	5.73	8.12	10.83	13.93	17.50	21.66
25 €/certificate		2.14	4.51	7.17	10.15	13.54	17.40	21.87	27.07
15 €/certificate		1.30	2.80	4.50	6.30	8.40	10.80	13.60	16.80
20 €/certificate	1	1.80	3.70	5.90	8.40	11.20	14.40	18.10	22.40
25 €/certificate		2.20	4.70	7.40	10.50	14.00	18.00	22.60	28.00
15 €/certificate		1.21	2.55	4.05	5.73	7.65	9.83	12.35	15.29
20 €/certificate	2	1.61	3.40	5.40	7.64	10.19	13.10	16.46	20.38
25 €/certificate		2.01	4.25	6.74	9.55	12.74	16.38	20.57	25.47
30 €/certificate		2.57	5.41	8.60	12.18	16.24	20.88	26.24	32.48
35 €/certificate	3	2.99	6.32	10.03	14.21	18.95	24.36	30.61	37.89
40 €/certificate		3.42	7.22	11.46	16.24	21.65	27.84	34.98	43.30
30 €/certificate		2.66	5.60	8.90	12.61	16.81	21.61	27.15	33.62
35 €/certificate	4	3.10	6.54	10.38	14.71	19.61	25.21	31.68	39.22
40 €/certificate		3.54	7.47	11.86	16.81	22.41	28.81	36.20	44.82
30 €/certificate		2.42	5.09	8.09	11.46	15.28	19.65	24.69	30.56
35 €/certificate	5	2.81	5.94	9.44	13.37	17.83	22.92	28.80	35.65
40 €/certificate		3.22	6.79	10.79	15.28	20.37	26.19	32.91	40.75

Table 4.2 (continued)

<i>Refinery</i>									
<b>Impact of costs for purchasing and trading of allowances, %</b>									
15 €/certificate	0	0.10	0.13	0.17	0.20	0.25	0.30	0.35	0.42
20 €/certificate		0.11	0.15	0.20	0.25	0.30	0.37	0.44	0.53
25 €/certificate		0.12	0.17	0.23	0.29	0.36	0.44	0.54	0.65
15 €/certificate	1	0.11	0.15	0.19	0.24	0.29	0.35	0.42	0.50
20 €/certificate		0.12	0.17	0.23	0.29	0.36	0.44	0.54	0.65
25 €/certificate		0.13	0.19	0.26	0.34	0.43	0.53	0.65	0.79
15 €/certificate	2	0.10	0.14	0.18	0.22	0.27	0.32	0.39	0.46
20 €/certificate		0.11	0.16	0.21	0.27	0.33	0.41	0.49	0.59
25 €/certificate		0.12	0.18	0.24	0.32	0.40	0.49	0.60	0.72
30 €/certificate	3	0.13	0.19	0.26	0.33	0.42	0.52	0.63	0.76
35 €/certificate		0.14	0.21	0.29	0.38	0.48	0.59	0.72	0.88
40 €/certificate		0.15	0.23	0.32	0.42	0.53	0.66	0.82	0.99
30 €/certificate	4	0.14	0.22	0.30	0.40	0.50	0.63	0.77	0.93
35 €/certificate		0.15	0.24	0.34	0.45	0.58	0.72	0.88	1.08
40 €/certificate		0.16	0.27	0.38	0.50	0.65	0.81	1.00	1.22
30 €/certificate	5	0.13	0.20	0.28	0.36	0.46	0.57	0.70	0.85
35 €/certificate		0.14	0.22	0.31	0.41	0.53	0.65	0.80	0.98
40 €/certificate		0.16	0.25	0.35	0.46	0.59	0.74	0.91	1.11
<i>Ferrous metals</i>									
<b>Impact of costs for purchasing and trading of allowances, %</b>									
15 €/certificate	0	0.70	0.76	0.83	0.90	0.99	1.09	1.20	1.33
20 €/certificate		0.72	0.80	0.89	0.99	1.10	1.23	1.38	1.56
25 €/certificate		0.74	0.84	0.95	1.07	1.22	1.38	1.56	1.78
15 €/certificate	1	0.70	0.77	0.85	0.93	1.03	1.14	1.27	1.41
20 €/certificate		0.72	0.81	0.92	1.03	1.16	1.30	1.47	1.67
25 €/certificate		0.74	0.86	0.98	1.12	1.29	1.47	1.68	1.93
15 €/certificate	2	0.72	0.79	0.88	0.97	1.08	1.20	1.35	1.51
20 €/certificate		0.74	0.84	0.95	1.08	1.22	1.39	1.58	1.80
25 €/certificate		0.76	0.89	1.03	1.19	1.37	1.57	1.81	2.09

Table 4.2 (continued)

30 €/certificate		0.76	0.88	1.02	1.17	1.35	1.55	1.78	2.05
35 €/certificate	3	0.78	0.92	1.08	1.26	1.46	1.70	1.96	2.28
40 €/certificate		0.79	0.96	1.14	1.35	1.58	1.85	2.15	2.51
30 €/certificate		0.76	0.90	1.05	1.22	1.41	1.63	1.89	2.18
35 €/certificate	4	0.79	0.94	1.12	1.32	1.54	1.80	2.09	2.44
40 €/certificate		0.81	0.99	1.19	1.41	1.67	1.96	2.30	2.70
30 €/certificate		0.79	0.94	1.11	1.30	1.51	1.76	2.04	2.38
35 €/certificate	5	0.81	0.99	1.18	1.41	1.66	1.95	2.28	2.66
40 €/certificate		0.83	1.03	1.26	1.51	1.80	2.13	2.51	2.95
<b>Cement</b>									
<b>Impact of costs for purchasing and trading of allowances, %</b>									
15 €/certificate		1.53	2.40	3.37	4.46	5.70	7.12	8.75	10.66
20 €/certificate	0	1.79	2.95	4.25	5.70	7.35	9.24	11.42	13.95
25 €/certificate		2.05	3.50	5.12	6.94	9.00	11.36	14.08	17.25
15 €/certificate		1.93	3.23	4.69	6.34	8.20	10.33	12.79	15.65
20 €/certificate	1	2.32	4.06	6.01	8.20	10.68	13.52	16.80	20.62
25 €/certificate		2.71	4.89	7.32	10.06	13.17	16.71	20.81	25.58
15 €/certificate		1.82	3.01	4.34	5.83	7.52	9.46	11.69	14.30
20 €/certificate	2	2.18	3.76	5.53	7.52	9.78	12.36	15.34	18.81
25 €/certificate		2.53	4.51	6.73	9.22	12.04	15.26	18.98	23.33
30 €/certificate		2.31	4.05	5.99	8.18	10.65	13.48	16.75	20.55
35 €/certificate	3	2.57	4.60	6.87	9.41	12.30	15.60	19.41	23.85
40 €/certificate		2.83	5.15	7.74	10.65	13.95	17.72	22.08	27.15
30 €/certificate		3.10	5.72	8.64	11.92	15.65	19.91	24.82	30.55
35 €/certificate	4	3.49	6.54	9.95	13.79	18.13	23.10	28.83	35.51
40 €/certificate		3.89	7.37	11.27	15.65	20.61	26.29	32.84	40.48
30 €/certificate		2.89	5.27	7.92	10.91	14.30	18.17	22.63	27.84
35 €/certificate	5	3.25	6.02	9.12	12.60	16.55	21.07	26.28	32.35
40 €/certificate		3.60	6.77	10.31	14.29	18.81	23.97	29.92	36.87

Table 4.2 (continued)

<i>Lime</i>									
<b>Impact of costs for purchasing and trading of allowances, %</b>									
15 €/certificate	0	0.89	1.74	2.70	3.78	5.00	6.40	8.01	9.89
20 €/certificate		1.14	2.29	3.56	5.00	6.63	8.49	10.64	13.15
25 €/certificate		1.40	2.83	4.43	6.22	8.26	10.59	13.27	16.40
15 €/certificate	1	1.06	2.11	3.28	4.60	6.09	7.80	9.77	12.07
20 €/certificate		1.37	2.77	4.33	6.09	8.08	10.36	12.99	16.05
25 €/certificate		1.69	3.44	5.39	7.58	10.07	12.92	16.20	20.03
15 €/certificate	2	0.97	1.93	2.99	4.19	5.55	7.10	8.90	10.99
20 €/certificate		1.26	2.53	3.95	5.55	7.36	9.43	11.82	14.61
25 €/certificate		1.55	3.13	4.91	6.91	9.17	11.76	14.74	18.23
30 €/certificate	3	1.66	3.37	5.29	7.44	9.89	12.68	15.90	19.66
35 €/certificate		1.92	3.92	6.15	8.66	11.51	14.77	18.53	22.91
40 €/certificate		2.17	4.46	7.01	9.89	13.14	16.86	21.16	26.17
30 €/certificate	4	2.00	4.10	6.44	9.08	12.06	15.48	19.42	24.01
35 €/certificate		2.32	4.76	7.50	10.57	14.06	18.04	22.63	27.99
40 €/certificate		2.63	5.43	8.55	12.06	16.05	20.60	25.85	31.98
30 €/certificate	5	1.83	3.74	5.87	8.26	10.98	14.08	17.66	21.84
35 €/certificate		2.12	4.34	6.82	9.62	12.79	16.41	20.59	25.46
40 €/certificate		2.40	4.94	7.78	10.98	14.60	18.74	23.51	29.08
<i>Pulp and paper</i>									
<b>Impact of costs for purchasing and trading of allowances, %</b>									
15 €/certificate	0	0.69	0.82	0.97	1.13	1.32	1.54	1.79	2.08
20 €/certificate		0.73	0.90	1.10	1.32	1.58	1.87	2.20	2.59
25 €/certificate		0.77	0.99	1.23	1.51	1.83	2.19	2.61	3.09
15 €/certificate	1	0.71	0.88	1.08	1.29	1.53	1.81	2.14	2.51
20 €/certificate		0.76	0.99	1.25	1.53	1.86	2.23	2.66	3.16
25 €/certificate		0.81	1.10	1.42	1.78	2.18	2.65	3.18	3.81
15 €/certificate	2	0.74	0.93	1.15	1.39	1.66	1.98	2.34	2.76
20 €/certificate		0.80	1.05	1.34	1.66	2.03	2.45	2.93	3.49
25 €/certificate		0.86	1.18	1.53	1.94	2.39	2.91	3.52	4.22

Table 4.2 (continued)

30 €/certificate		0.81	1.07	1.37	1.70	2.08	2.51	3.01	3.60
35 €/certificate	3	0.85	1.16	1.50	1.89	2.33	2.84	3.42	4.10
40 €/certificate		0.89	1.24	1.64	2.08	2.59	3.16	3.83	4.61
30 €/certificate		0.87	1.21	1.59	2.02	2.51	3.07	3.71	4.46
35 €/certificate	4	0.92	1.32	1.76	2.26	2.83	3.48	4.23	5.11
40 €/certificate		0.97	1.42	1.93	2.51	3.16	3.90	4.76	5.76
30 €/certificate		0.91	1.30	1.73	2.21	2.76	3.38	4.10	4.95
35 €/certificate	5	0.97	1.42	1.92	2.48	3.12	3.85	4.69	5.67
40 €/certificate		1.03	1.54	2.11	2.76	3.48	4.32	5.28	6.40
<i>Glass</i>									
<b>Impact of costs for purchasing and trading of allowances, %</b>									
15 €/certificate		1.95	2.51	3.14	3.84	4.64	5.56	6.61	7.84
20 €/certificate	0	2.12	2.86	3.70	4.64	5.71	6.93	8.33	9.97
25 €/certificate		2.28	3.22	4.26	5.44	6.77	8.30	10.05	12.10
15 €/certificate		2.01	2.65	3.36	4.15	5.06	6.09	7.28	8.67
20 €/certificate	1	2.20	3.05	3.99	5.06	6.26	7.64	9.22	11.08
25 €/certificate		2.39	3.45	4.63	5.96	7.46	9.18	11.17	13.49
15 €/certificate		2.07	2.78	3.56	4.44	5.45	6.59	7.91	9.45
20 €/certificate	2	2.28	3.22	4.27	5.44	6.78	8.30	10.06	12.12
25 €/certificate		2.50	3.67	4.97	6.44	8.11	10.02	12.22	14.78
30 €/certificate		2.45	3.57	4.83	6.24	7.84	9.67	11.77	14.23
35 €/certificate	3	2.62	3.93	5.39	7.04	8.90	11.04	13.49	16.36
40 €/certificate		2.79	4.28	5.96	7.84	9.97	12.41	15.22	18.50
30 €/certificate		2.58	3.85	5.27	6.86	8.67	10.73	13.11	15.89
35 €/certificate	4	2.77	4.25	5.91	7.76	9.87	12.28	15.06	18.30
40 €/certificate		2.96	4.65	6.54	8.67	11.08	13.83	17.00	20.71
30 €/certificate		2.71	4.11	5.68	7.44	9.45	11.73	14.37	17.45
35 €/certificate	5	2.92	4.55	6.39	8.45	10.78	13.45	16.53	20.12
40 €/certificate		3.13	5.00	7.09	9.45	12.11	15.16	18.68	22.78

Table 4.2 (continued)

<i>Ceramic</i>									
<b>Impact of costs for purchasing and trading of allowances, %</b>									
15 €/certificate	0	0.23	0.32	0.43	0.54	0.67	0.82	0.99	1.19
20 €/certificate		0.26	0.38	0.52	0.67	0.84	1.04	1.27	1.53
25 €/certificate		0.29	0.44	0.61	0.80	1.01	1.26	1.55	1.88
15 €/certificate	1	0.25	0.36	0.48	0.61	0.77	0.94	1.15	1.38
20 €/certificate		0.28	0.42	0.59	0.77	0.97	1.21	1.48	1.79
25 €/certificate		0.31	0.49	0.69	0.92	1.18	1.47	1.81	2.20
15 €/certificate	2	0.26	0.38	0.52	0.67	0.84	1.04	1.26	1.53
20 €/certificate		0.30	0.46	0.64	0.84	1.07	1.33	1.63	1.99
25 €/certificate		0.33	0.53	0.76	1.01	1.30	1.63	2.00	2.44
30 €/certificate	3	0.31	0.50	0.70	0.93	1.19	1.48	1.82	2.22
35 €/certificate		0.34	0.55	0.79	1.06	1.36	1.70	2.10	2.57
40 €/certificate		0.37	0.61	0.88	1.19	1.53	1.93	2.38	2.91
30 €/certificate	4	0.35	0.56	0.80	1.07	1.38	1.73	2.14	2.61
35 €/certificate		0.38	0.63	0.91	1.23	1.59	2.00	2.47	3.02
40 €/certificate		0.41	0.70	1.02	1.38	1.79	2.26	2.80	3.43
30 €/certificate	5	0.37	0.61	0.88	1.18	1.53	1.92	2.37	2.90
35 €/certificate		0.41	0.69	1.00	1.36	1.76	2.21	2.74	3.36
40 €/certificate		0.44	0.76	1.12	1.53	1.99	2.51	3.11	3.82
<i>Energy and lime</i>									
<b>Impact of costs for purchasing and trading of allowances, %</b>									
15 €/certificate	0	0.13	0.18	0.24	0.31	0.39	0.48	0.58	0.70
20 €/certificate		0.15	0.22	0.30	0.39	0.50	0.62	0.75	0.91
25 €/certificate		0.16	0.25	0.35	0.47	0.60	0.75	0.92	1.12
15 €/certificate	1	0.15	0.22	0.31	0.41	0.52	0.64	0.78	0.95
20 €/certificate		0.17	0.27	0.39	0.52	0.66	0.83	1.02	1.24
25 €/certificate		0.19	0.32	0.46	0.62	0.81	1.01	1.25	1.53
15 €/certificate	2	0.16	0.24	0.34	0.44	0.56	0.70	0.86	1.05
20 €/certificate		0.18	0.29	0.42	0.56	0.72	0.91	1.12	1.37
25 €/certificate		0.21	0.35	0.51	0.68	0.89	1.12	1.38	1.69

Table 4.2 (continued)

30 €/certificate		0.18	0.29	0.41	0.55	0.70	0.88	1.09	1.33
35 €/certificate	3	0.19	0.32	0.47	0.63	0.81	1.02	1.26	1.54
40 €/certificate		0.21	0.36	0.52	0.70	0.91	1.15	1.43	1.75
30 €/certificate		0.22	0.37	0.54	0.73	0.95	1.20	1.49	1.82
35 €/certificate	4	0.24	0.42	0.62	0.84	1.10	1.39	1.72	2.11
40 €/certificate		0.26	0.47	0.69	0.95	1.24	1.57	1.96	2.40
30 €/certificate		0.23	0.40	0.59	0.80	1.05	1.32	1.64	2.01
35 €/certificate	5	0.26	0.46	0.68	0.93	1.21	1.53	1.90	2.34
40 €/certificate		0.28	0.51	0.76	1.05	1.37	1.74	2.16	2.66
<i>Non-ferrous metals</i>									
<b>Impact of costs for purchasing and trading of allowances, %</b>									
15 €/certificate		1.25	1.89	2.61	3.41	4.33	5.37	6.58	7.98
20 €/certificate	1	1.44	2.30	3.25	4.33	5.55	6.94	8.54	10.42
25 €/certificate		1.63	2.70	3.90	5.24	6.76	8.50	10.51	12.85
30 €/certificate		1.83	3.11	4.54	6.15	7.98	10.07	12.48	15.29
35 €/certificate	4	2.02	3.51	5.19	7.07	9.20	11.63	14.44	17.72
40 €/certificate		2.21	3.92	5.83	7.98	10.41	13.20	16.41	20.16
<i>Chemical industry</i>									
<b>Impact of costs for purchasing and trading of allowances, %</b>									
15 €/certificate		1.30	2.17	3.15	4.24	5.48	6.90	8.54	10.45
20 €/certificate	1	1.56	2.73	4.02	5.48	7.14	9.03	11.21	13.75
25 €/certificate		1.83	3.28	4.90	6.72	8.79	11.15	13.88	17.06
30 €/certificate		2.09	3.83	5.77	7.96	10.44	13.28	16.55	20.37
35 €/certificate	4	2.35	4.38	6.65	9.20	12.10	15.40	19.22	23.67
40 €/certificate		2.61	4.93	7.52	10.44	13.75	17.53	21.89	26.98



The following conclusions can be drawn from Table 4.2:

- The share of additional costs for purchasing and trading from production costs increases as the price of allowance increases and the percentage of allowances not allocated;
- The share of additional costs for purchasing and trading from production costs increases if it is taken into account the electricity purchased;
- The share of additional costs for purchasing and trading from production costs increases as the average annual production decreases;
- The impact of ETS can be reduced by investment that will lead to reduced energy consumption and, therefore, lower emissions of CO<sub>2</sub>;

Further is presented a detailed analysis of additional costs for purchasing and trading of emission allowances for 2013, due to the application of trading scheme ETS compared to the situation without application of it.

#### 4.2.1 Energy activities

The following sectors are analyzed:

- Energy;
- Refinery.

##### **Energy sector**

(A) Installation no. 1 is an electricity generating unit.

No free allocation is given to producers of electricity, except two possibilities:

- By transitional derogation [E2], Member States may allocate free allowances to installations for electricity production in operation by 31 December 2008, for the modernization of electricity generation, provided that one of the following conditions is met: (i) the national electricity network was not directly or indirectly connected to the network interconnected system operated by the Union for the Coordination of Transmission of Electricity (UCTE), in 2007; (ii) the national electricity network was only directly or indirectly connected to the network operated by UCTE through a single line with a capacity of less than 400 MW, in 2007; (iii) in 2006, more than 30% of electricity was produced from a single fossil fuel, and the GDP per capita at market price did not exceed 50% of the average GDP per capita at market price of the Community (Romania meets this condition);
- Electricity produced from waste gases.

The Member State concerned shall submit to the Commission a national plan that provides for investments in retrofitting and upgrading of the infrastructure and clean technologies. The national plan shall also provide for the diversification of their energy mix and sources of supply for an amount equivalent. The Member State concerned shall submit to the Commission, every year, a report on investments made in upgrading infrastructure and clean technologies.

In 2013, the total transitional free allocation shall not exceed 70% of the annual average verified emissions in 2005-2007 from such electricity generators for the amount corresponding to the gross final national consumption of the Member State concerned and shall gradually decrease, resulting in no free allocation in 2020. For Romania will be taken into account verified emissions from 2007.

Allocation to operators shall be based on the allocation under the verified emissions in 2005-2007 or an ex-ante efficiency benchmark based on the weighted average of emission levels of most greenhouse gas efficient electricity production covered by the Community scheme for installations using different fuels. The weighting may reflect the shares of the different fuels in electricity production in the Member State concerned.

So, the total percentage of allowances not allocated in case of electricity producers will have a value of 30% (taking into account that 70% are allocated free by transitional allocation).

When no free allowances are allocated to electricity producers, that means they will have to buy 100% quantity of allowances, which will lead to an unacceptable increase in electricity price.

The influence of additional costs on the increase of production costs for an electricity generating installation, in 2013, is further presented for each case study.

Case study 0:

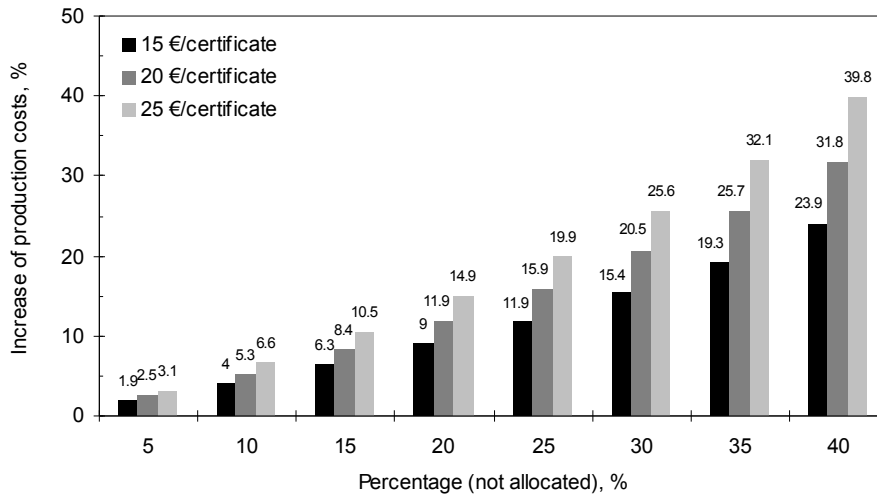

Figure 4.1. Impact of costs for purchasing and trading of allowances, in 2013, (Installation no. 1 – Case study 0)

From Figure 4.1 it can be seen that for an average price of 20 €/certificate, there is an increase of cost between approximately 16 and 21% for the case when 25-30% of certificates are required to be purchased.

Case study 1: Figure 4.2 shows that for an average price of 20 €/certificate, there is an increase of cost between 16.5 and 21.2% in same range of certificates to be purchased.

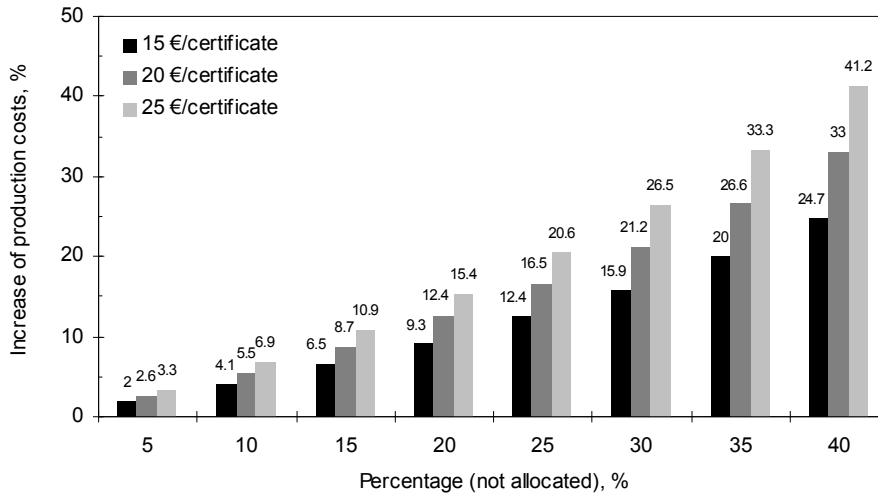

Figure 4.2. Impact of costs for purchasing and trading of allowances, in 2013, (Installation no. 1 – Case study 1)

Case study 2: For an average price of 20 €/certificate, there is an increase of cost between 16.1 and 20.7% in the range of 25-30% of certificates to be purchased, Figure 4.3.

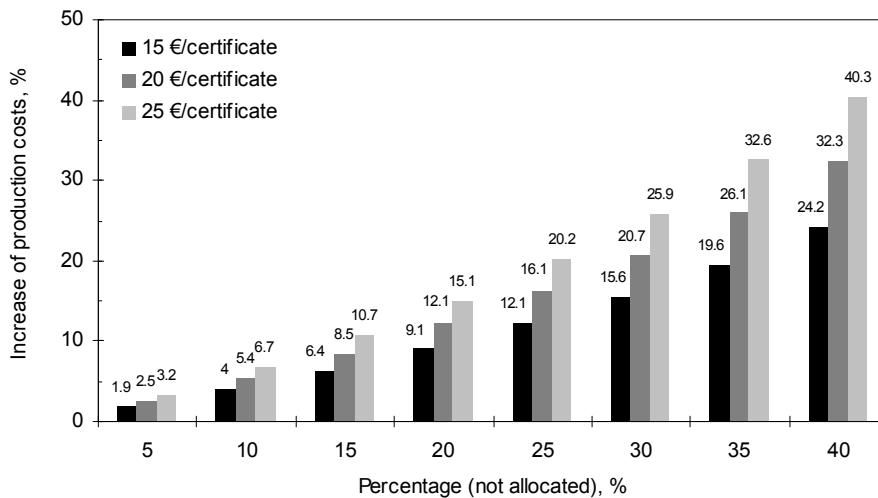

Figure 4.3. Impact of costs for purchasing and trading of allowances, in 2013, (Installation no. 1 – Case study 2)

Case study 3: For an average price of 35 €/certificate, there is an increase of cost between 27.8 and 35.8% in the range of 25-30% of certificates to be purchased, Figure 4.4.

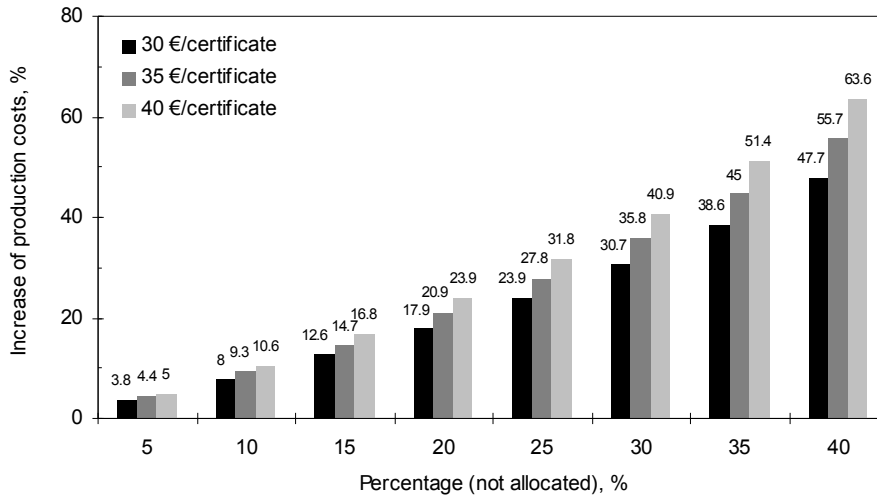

Figure 4.4. Impact of costs for purchasing and trading of allowances, in 2013, (Installation no. 1 – Case study 3)

Case study 4: For an average price of 35 €/certificate, there is an increase of cost between 28.8 and 37.1% in the range of 25-30% of certificates to be purchased, Figure 4.5.

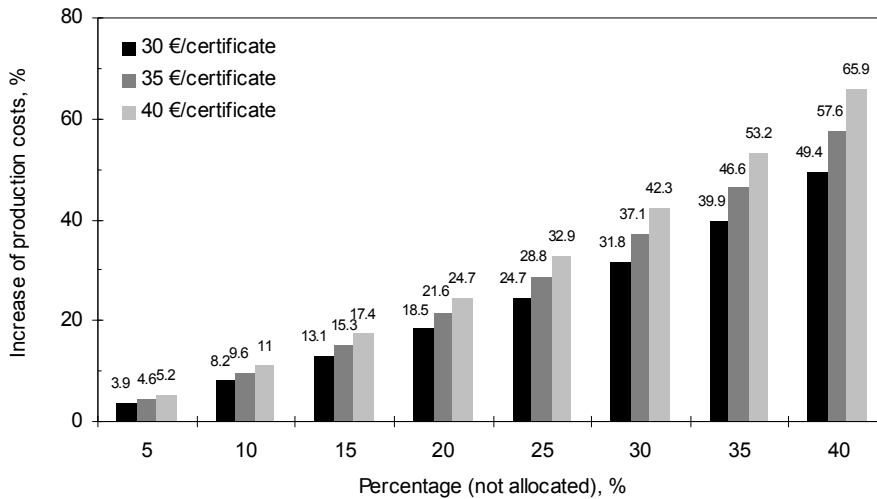

Figure 4.5. Impact of costs for purchasing and trading of allowances, in 2013, (Installation no. 1 – Case study 4)

Case study 5: For an average price of 35 €/certificate, there is an increase of cost between 28.2 and 36.3% in the range of 25-30% of certificates to be purchased, Figure 4.6.

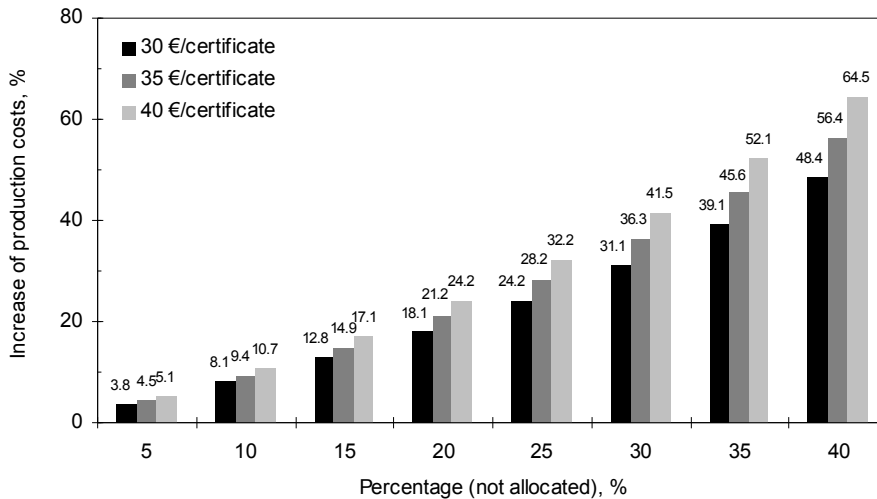

Figure 4.6. Impact of costs for purchasing and trading of allowances, in 2013, (Installation no. 1 – Case study 5)

The impact of ETS can be reduced by investment that will lead to reduced energy consumption and, therefore, lower emissions of CO<sub>2</sub>.

Figure 4.7 shows the maximum level of investment, correlated with minimum fuel reduction, which leads to the decision to invest in projects for the efficiency improvement, for the six levels of allowance price (15-40 €/certificate). For instance, for an average allowance price of 25 €, for an investment of 1% of the amount for plant replacement, if the reduction of fuel is more than 0.8%, then it is more profitable to make such investment than to purchase certificates with a price of 25 €.

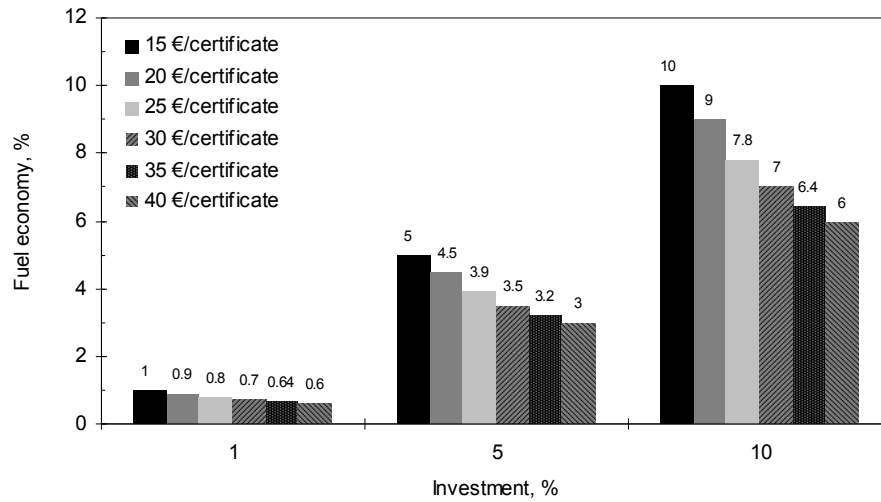

Figure 4.7. Investment in energy efficiency (Installation no. 1)

(B) Installation no. 2, it produces electrical and thermal energy.

According to Directive 2009/29/EC, free allocation is given to district heating as well as to high efficiency cogeneration, as defined by Directive 2004/8/EC, for economically justifiable demand, in respect of the production of heating or cooling. The amount of allowances allocated free of charge is as follows:

- In 2013, 80% of the quantity determined;
- After 2014, the free allocation should decrease each year by equal amounts resulting in 30% free allocation in 2020 and no free allocation in 2027.

So, 20% of certificates should be purchased by auction for central heating installations.

Case study 0: For an average price of 20 €/certificate, there is an increase in cost of electricity between 11.1 and 14.3% in the range of 25-30% of certificates to be purchased, Figure 4.8.

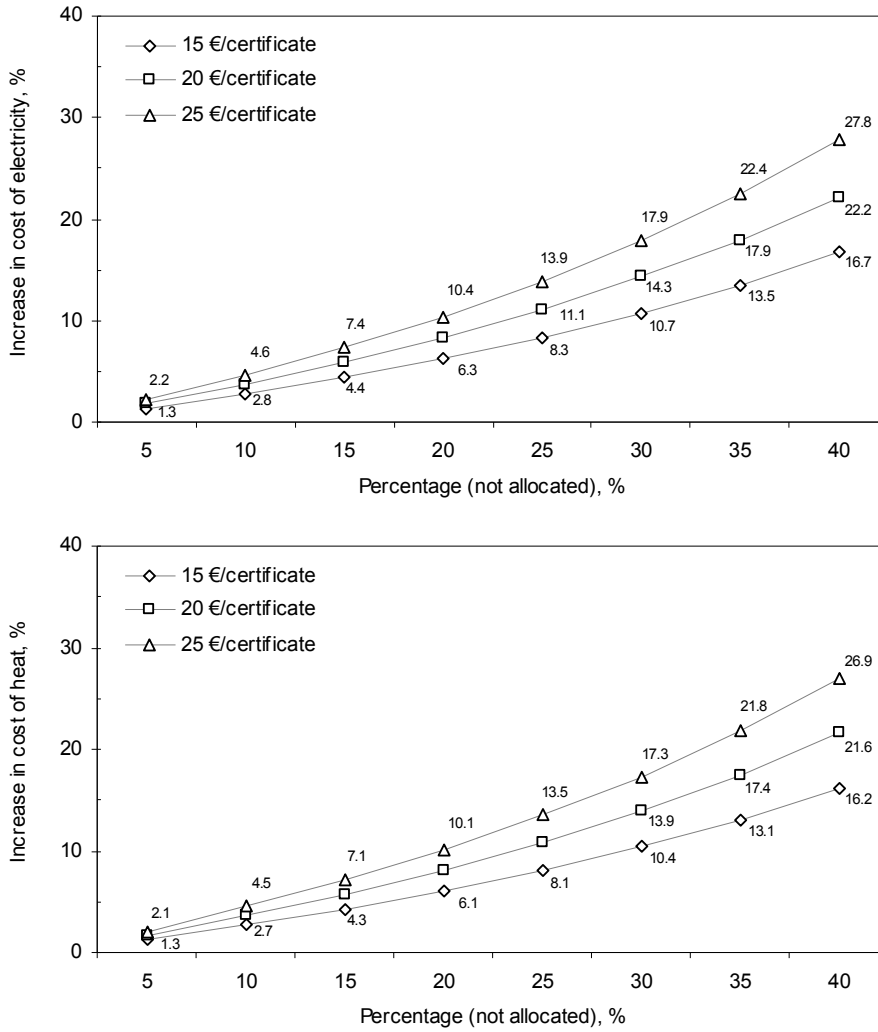

Figure 4.8. Impact of costs for purchasing and trading of allowances, in 2013, (top) electrical energy and (bottom) thermal energy, (Installation no. 2 - Case study 0)

Case study 1: For an average price of 20 €/certificate, there is an increase in cost of electricity between 11.5 and 14% in the range of 25-30% of certificates to be purchased, Figure 4.9.

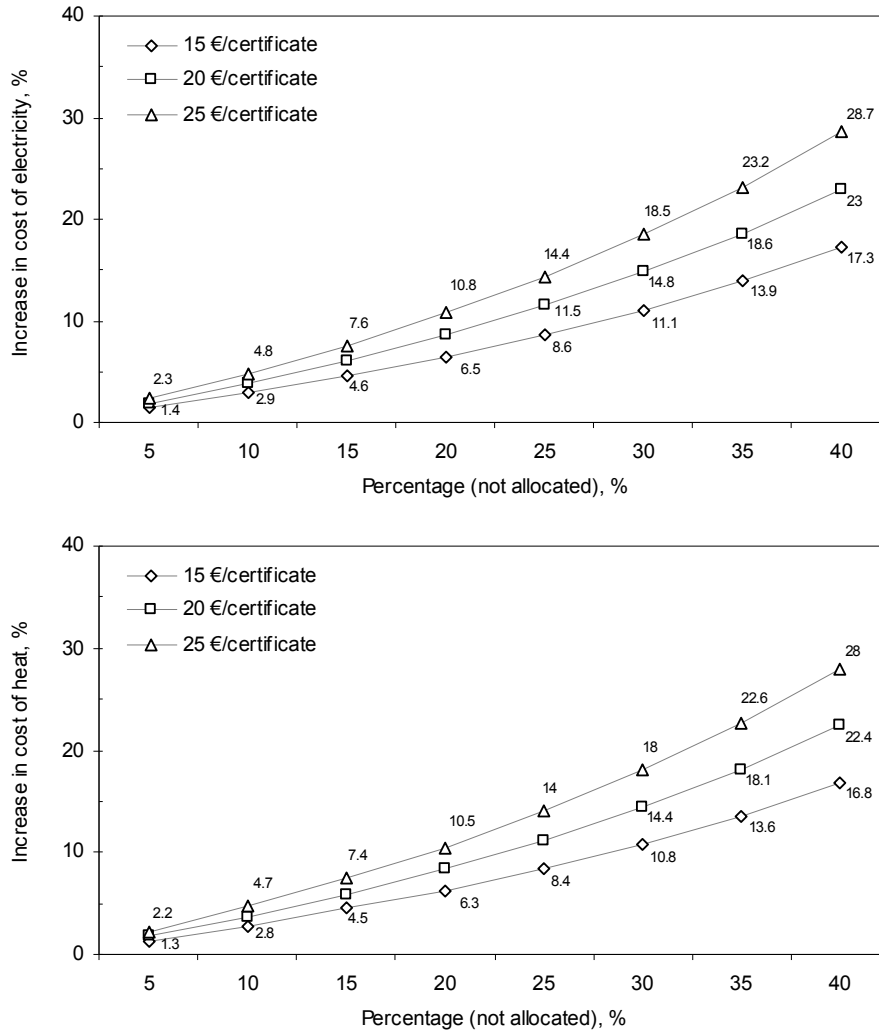

Figure 4.9. Impact of costs for purchasing and trading of allowances, in 2013, (top) electrical energy and (bottom) thermal energy, (Installation no. 2 - Case study 1)



Case study 2: For an average price of 20 €/certificate, there is an increase in cost of electricity between 10.5 and 13.4% in the range of 25-30% of certificates to be purchased, Figure 4.10.

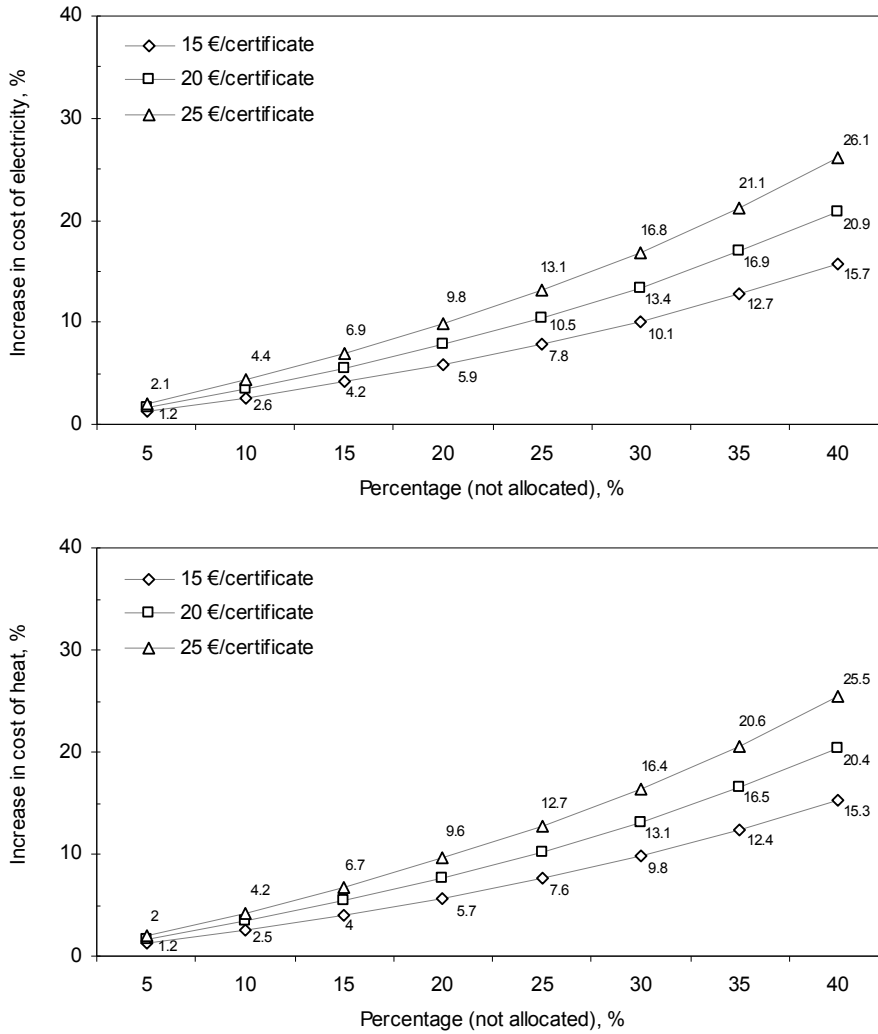

Figure 4.10. Impact of costs for purchasing and trading of allowances, in 2013, (top) electrical energy and (bottom) thermal energy, (Installation no. 2 - Case study 2)

Case study 3: For an average price of 35 €/certificate, there is an increase in cost of electricity between 19.4 and 25% in the range of 25-30% of certificates to be purchased, Figure 4.11.

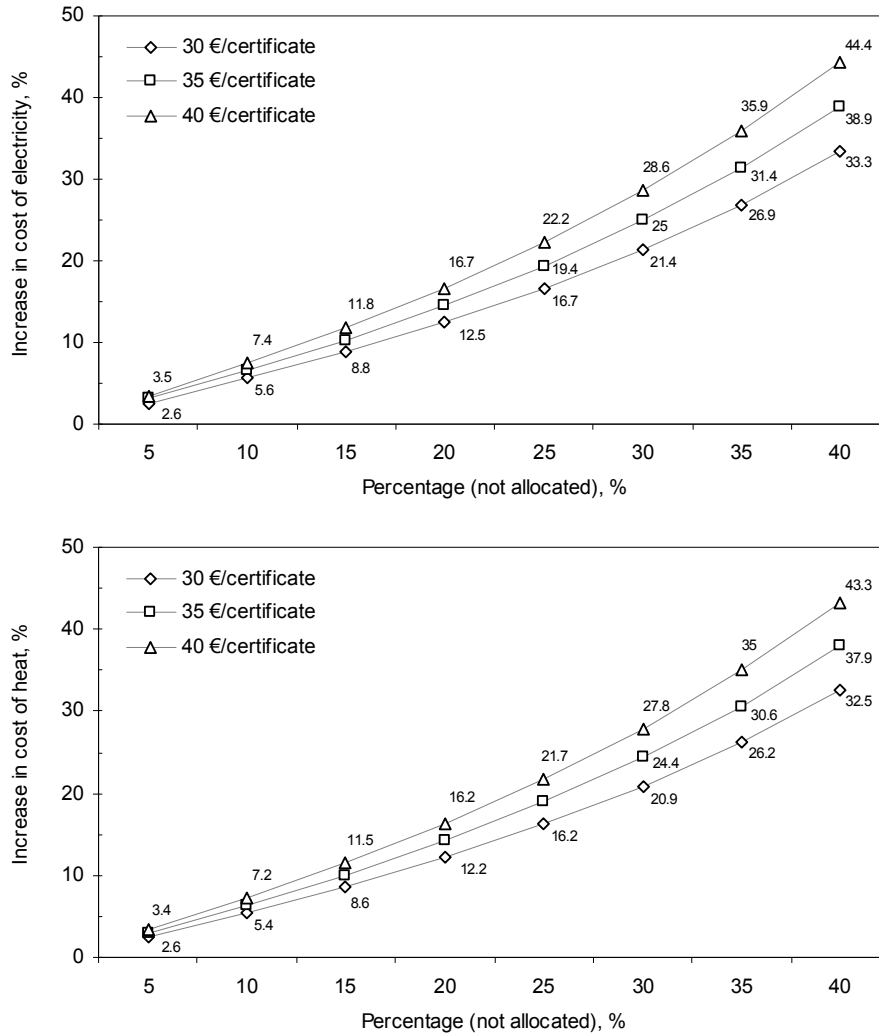

Figure 4.11. Impact of costs for purchasing and trading of allowances, in 2013, (top) electrical energy and (bottom) thermal energy, (Installation no. 2 - Case study 3)

Case study 4: For an average price of 35 €/certificate, there is an increase in cost of electricity between 20.1 and 25.9% in the range of 25-30% of certificates to be purchased, Figure 4.12.

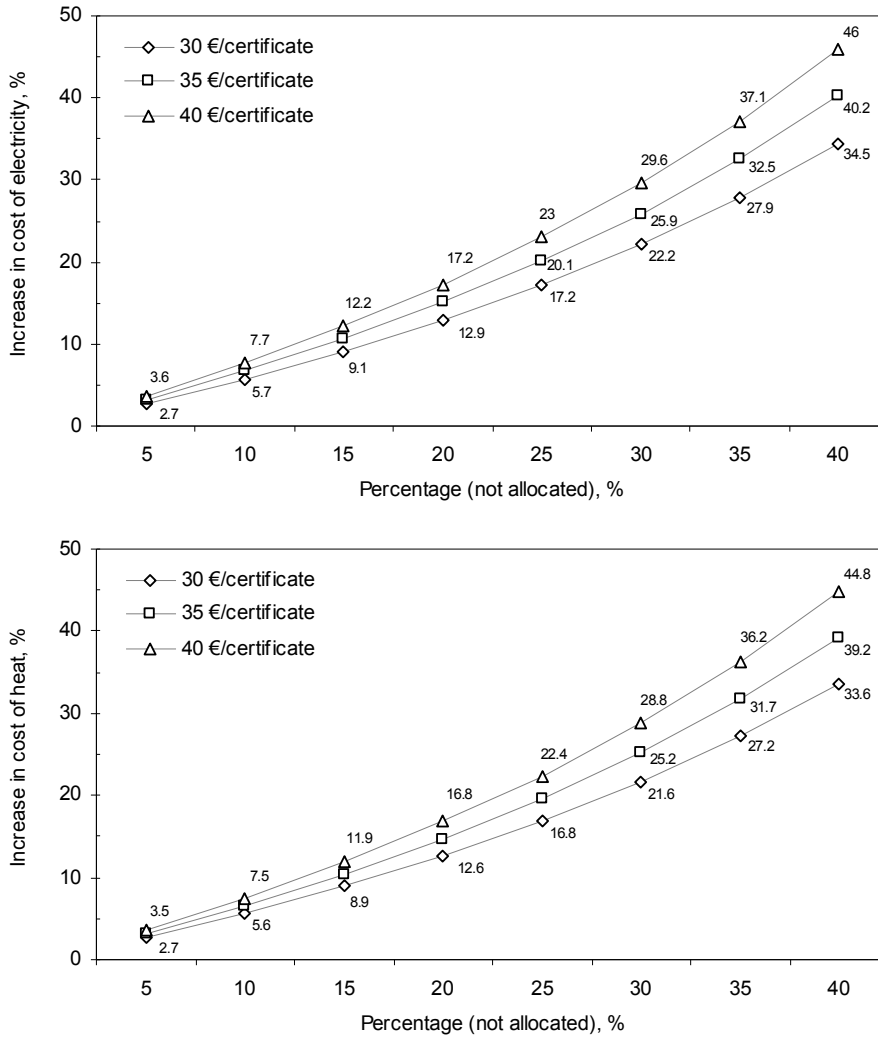

Figure 4.12. Impact of costs for purchasing and trading of allowances, in 2013, (top) electrical energy and (bottom) thermal energy, (Installation no. 2 – Case study 4)

Case study 5: For an average price of 35 €/certificate, there is an increase in cost of electricity between 18.3 and 23.5% in the range of 25-30% of certificates to be purchased, Figure 4.13.

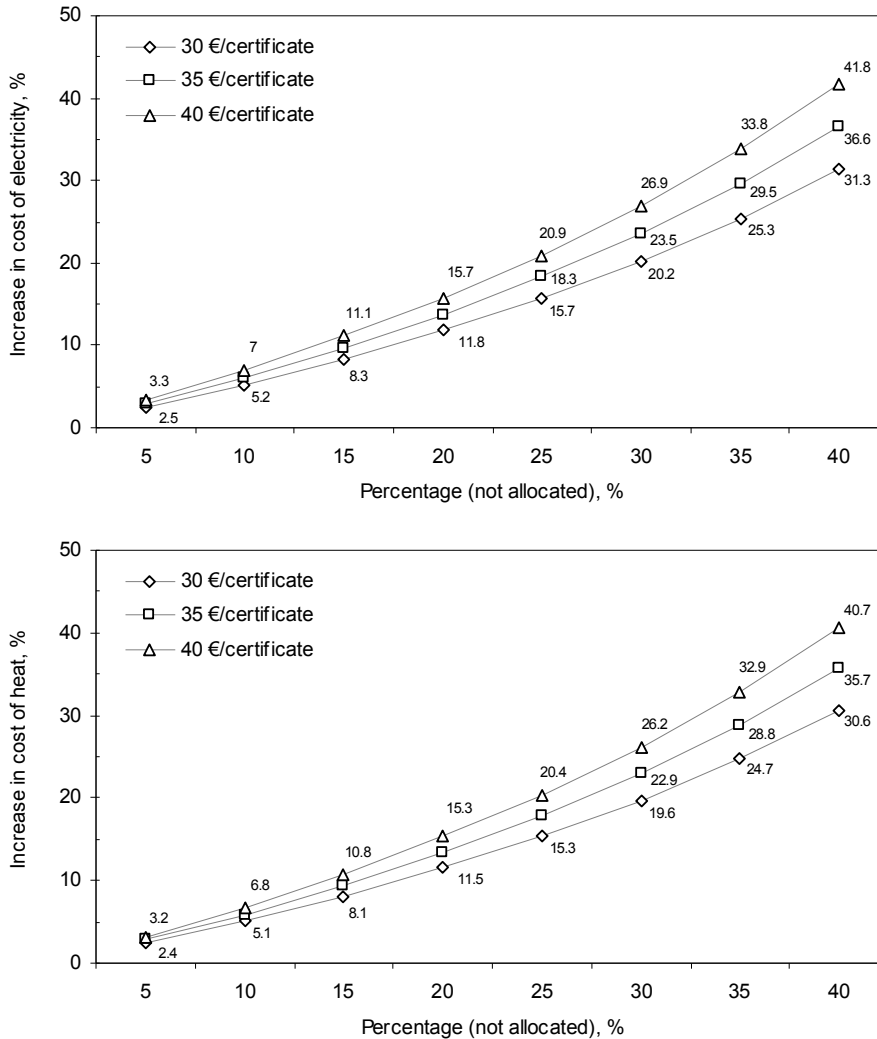

Figure 4.13. Impact of costs for purchasing and trading of allowances, in 2013, (top) electrical energy and (bottom) thermal energy, (Installation no. 2 - Case study 5)

For case studies 2 and 5, respectively, the production of electricity and heat is higher by 10% than in case studies 1 and 4, which leads to lower weighting of the ETS costs for these case studies.

The maximum level of investment, correlated with minimum fuel reduction, which leads to the decision to invest in projects for the efficiency improvement, for the six levels of allowance price (15-40 €/certificate) is shown in Figure 4.14. For an

average allowance price of 25 €, for an investment of 1% of the amount for plant replacement, if the reduction of fuel is more than 0.5%, then it is more profitable to make such investment than to purchase certificates with a price of 25 € per certificate.

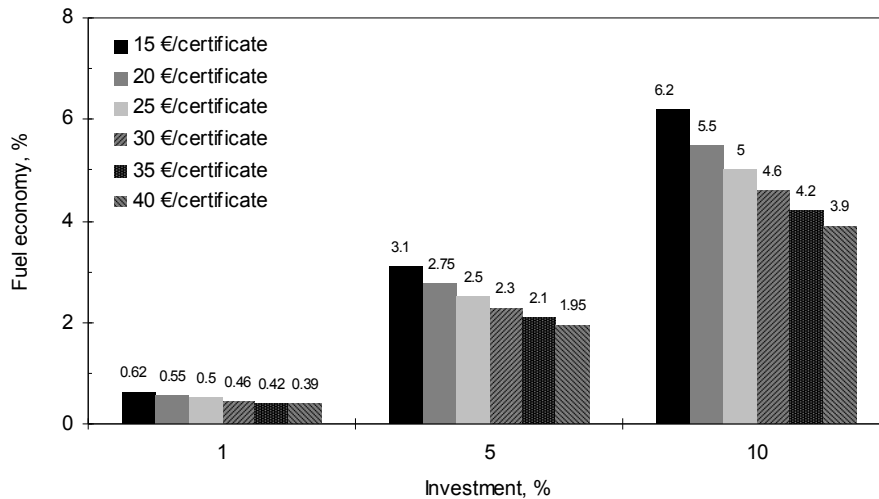

Figure 4.14. Investment in energy efficiency (Installation no. 2)

### **Refinery sector**

Installation no. 3 is an oil refining unit.

Installations in sectors and subsectors which are exposed to a significant risk of carbon leakage shall be allocated allowances free of charge at 100% of the quantity determined in accordance with the measures referred to in [E3].

So, 0% of certificates should be purchased by auction for refinery sector's installations (taking into account that 100% of certificates are allocated free of charge).

Case study 0: For an average price of 20 €/certificate, there is an increase in cost of production, including cost of electricity, between 0.3 and 0.37% in the range of 25-30% of certificates to be purchased, Figure 4.15.

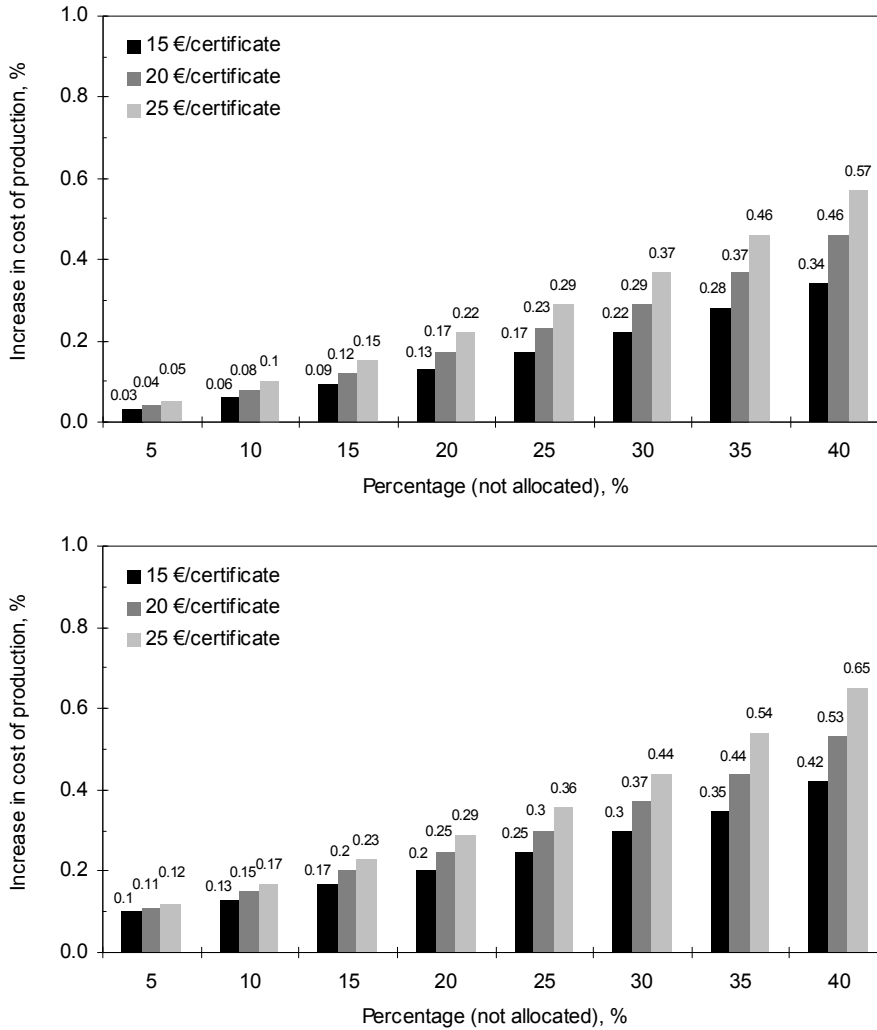

Figure 4.15. Impact of costs for purchasing and trading of allowances, in 2013, (top) without COE and (bottom) with COE, (Installation no. 3 – Case study 0)

Case study 1: For an average price of 20 €/certificate, there is an increase in cost of electricity production between 0.36 and 0.44% in the range of 25-30% of certificates to be purchased, Figure 4.16.

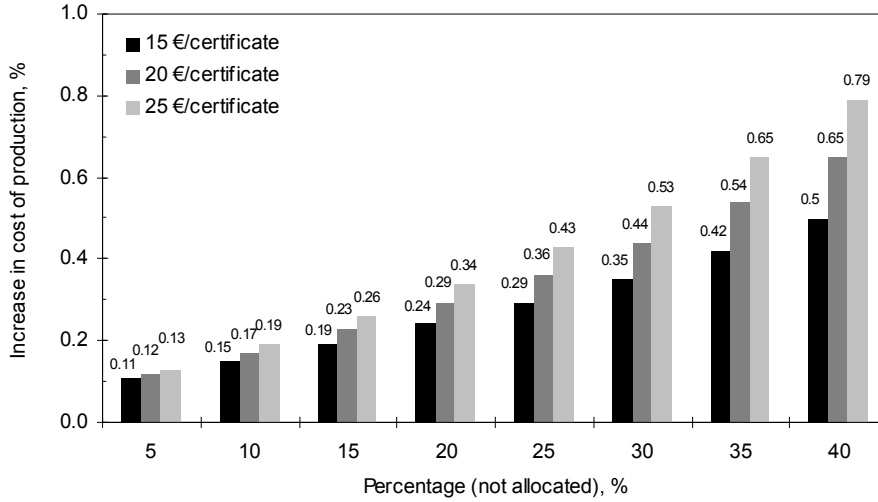

Figure 4.16. Impact of costs for purchasing and trading of allowances, in 2013, (Installation no. 3 – Case study 1)

Case study 2: For an average price of 20 €/certificate, there is an increase in cost of electricity production between 0.33 and 0.41% in the range of 25-30% of certificates to be purchased, Figure 4.17.

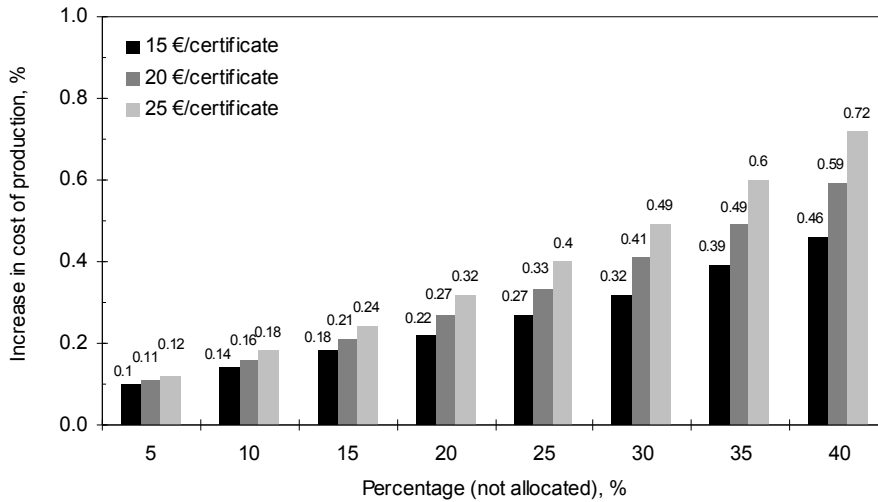

Figure 4.17. Impact of costs for purchasing and trading of allowances, in 2013, (Installation no. 3 – Case study 2)

Case study 3: For an average price of 35 €/certificate, there is an increase in cost of production (including electricity) between 0.48 and 0.59% in the range of 25-30% of certificates to be purchased, Figure 4.18.

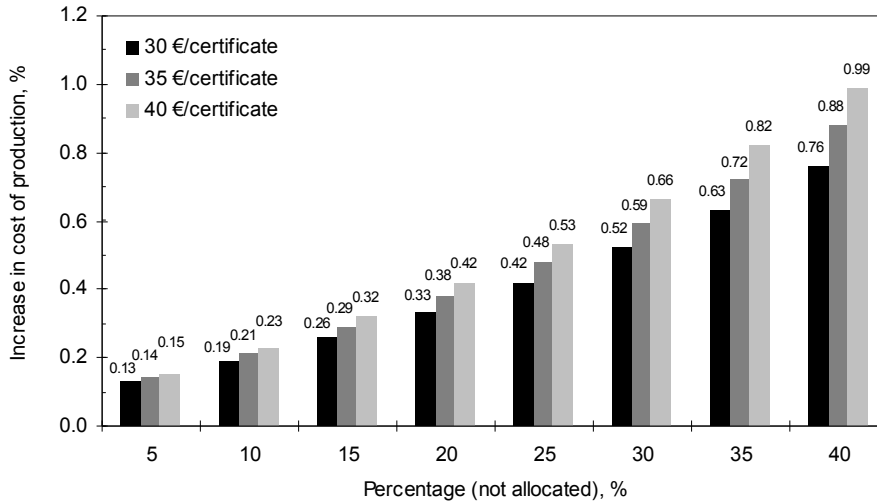

Figure 4.18. Impact of costs for purchasing and trading of allowances, in 2013, (Installation no. 3 – Case study 3)

Case study 4: For an average price of 35 €/certificate, there is an increase in cost of production (including electricity) between 0.58 and 0.72% in the range of 25-30% of certificates to be purchased, Figure 4.19.

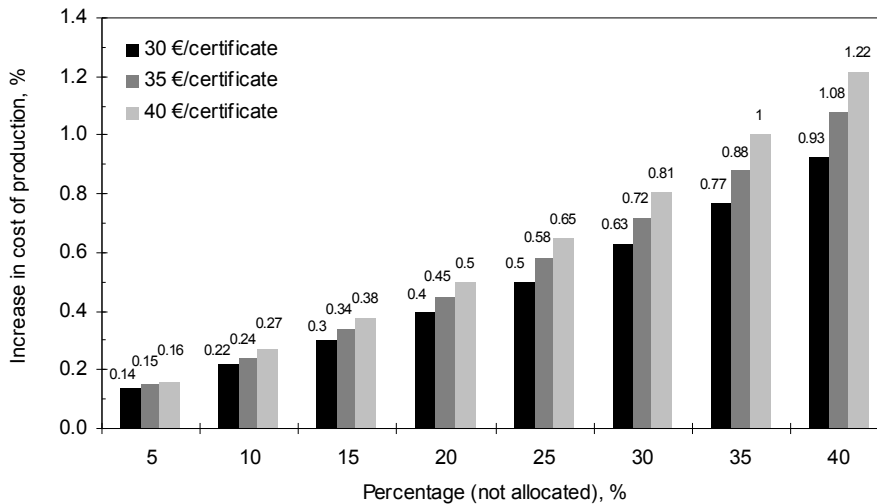

Figure 4.19. Impact of costs for purchasing and trading of allowances, in 2013, (Installation no. 3 – Case study 4)



Case study 5: For an average price of 35 €/certificate, there is an increase in cost of production (including electricity) between 0.45 and 0.58% in the range of 25-30% of certificates to be purchased, Figure 4.20.

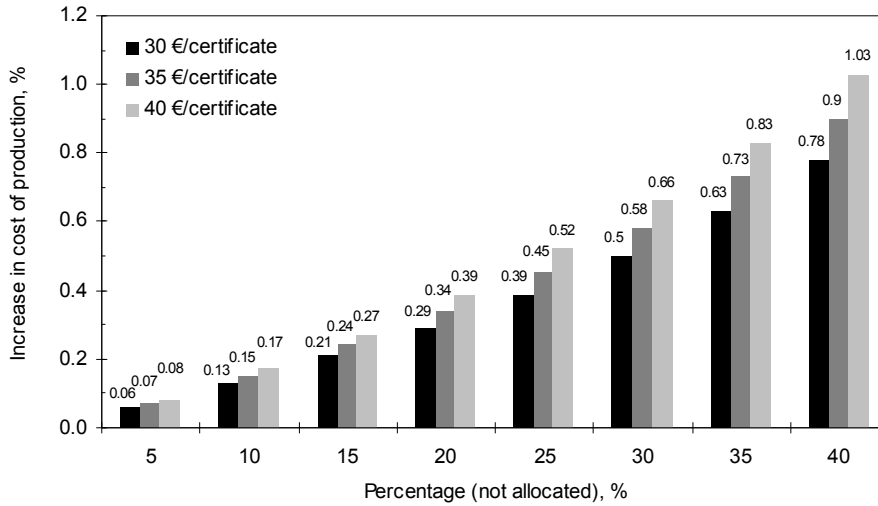

Figure 4.20. Impact of costs for purchasing and trading of allowances, in 2013, (Installation no. 3 – Case study 5)

According to Figure 4.21 for an average allowance price of 25 € with an investment of 0.05% of the amount for plant replacement and if the reduction of fuel is more than 3.8%, then it is more profitable to make such investment than to purchase certificates with a price of 25 € per certificate.

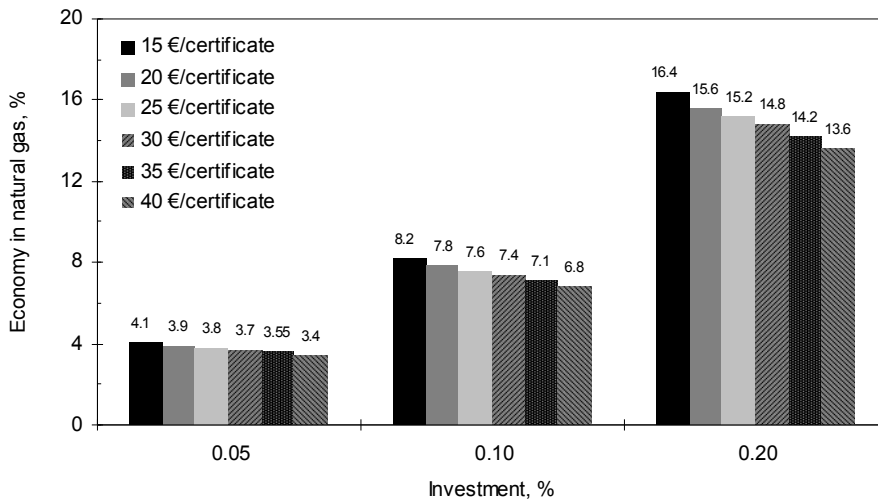

Figure 4.21. Investment in energy efficiency (Installation no. 3)

#### 4.2.2 Production and processing of ferrous metals

Installation no. 4, is designed for production and/or processing of ferrous metals, including ferro-alloys.

According to [E3], for industrial sectors and subsectors which are exposed to a significant risk of carbon leakage, which are listed in the published draft of the European Commission, 100% of allowances shall be allocated free of charge. However, there is a possibility that some subsectors will not be found on that list. In this way, they will have to buy the greenhouse gas emission allowances. Installations in sectors and subsectors which are exposed to a significant risk of carbon leakage should buy 0% of certificates from the auctioning of allowances.

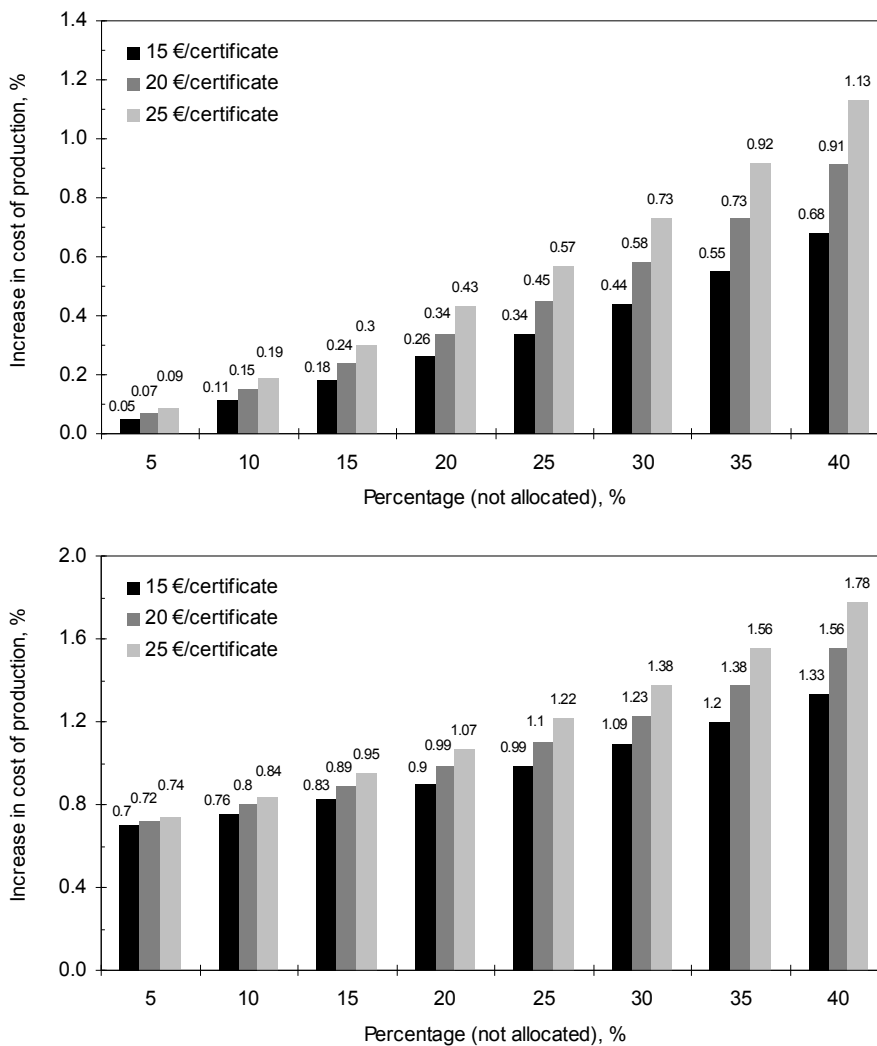

Figure 4.22. Impact of costs for purchasing and trading of allowances, in 2013, (top) without COE and (bottom) with COE, (Installation no. 4 – Case study 0)

Case study 0: For a price of 20 €/certificate, the weighting of the ETS costs (including the increase in cost of electricity) vary from 1.1% (when purchasing 25% of certificates) to 1.23% (when purchasing 30% of certificates), Figure 4.22.

It can be easily noted from Figure 4.22 that for 25% of certificates purchased the cost of production increases from 0.45% to 1.1% when the cost of electricity is included.

Case study 1: For an average price of 20 €/certificate, there is an increase in cost of production (including electricity) between 1.16 and 1.3% in the range of 25-30% of certificates to be purchased, Figure 4.23.

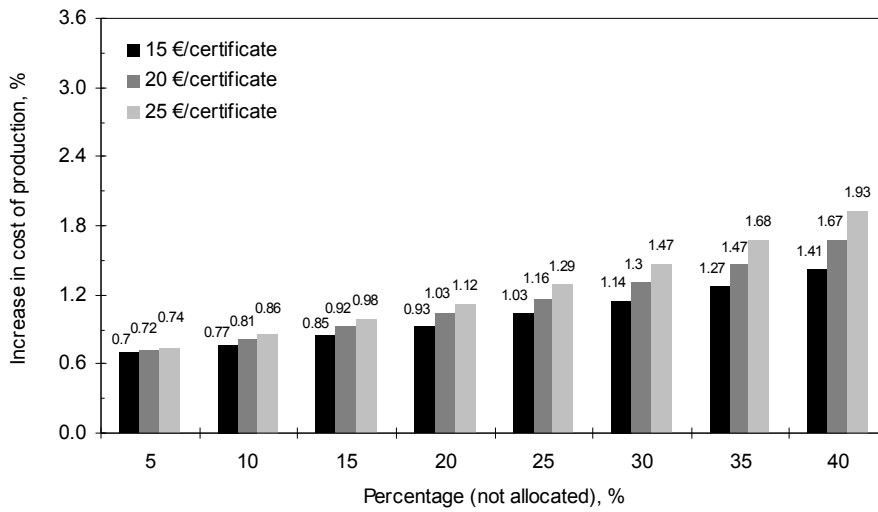

Figure 4.23. Impact of costs for purchasing and trading of allowances, in 2013, (Installation no. 4 – Case study 1)

Case study 2: For an average price of 20 €/certificate, there is an increase in cost of production (including electricity) between 1.22 and 1.39% in the range of 25-30% of needed certificates to be purchased, Figure 4.24.

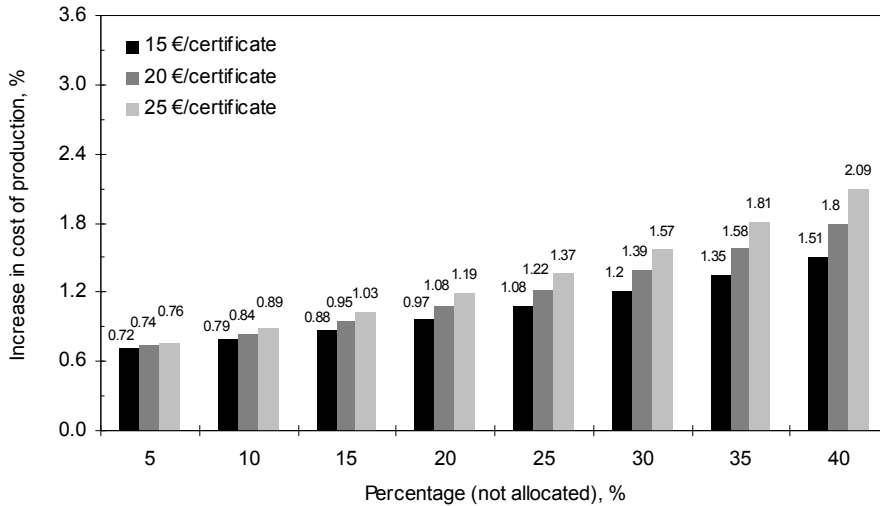

Figure 4.24. Impact of costs for purchasing and trading of allowances, in 2013, (Installation no. 4 – Case study 2)

Case study 3: For an average price of 35 €/certificate, there is an increase in cost of production (including electricity) between 1.46 and 1.7% in the range of 25-30% of needed certificates to be purchased, Figure 4.25.

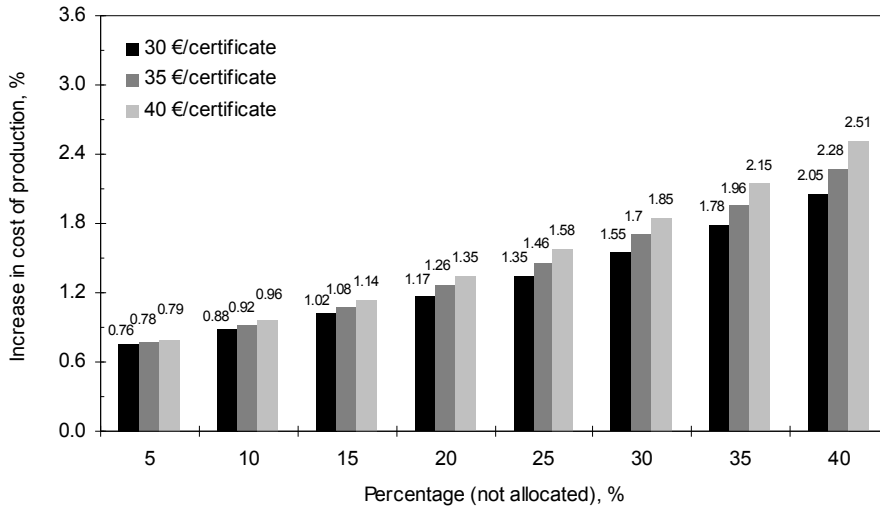

Figure 4.25. Impact of costs for purchasing and trading of allowances, in 2013, (Installation no. 4 – Case study 3)

Case study 4: For an average price of 35 €/certificate, there is an increase in cost of production (including electricity) between 1.54 and 1.8% in the range of 25-30% of needed certificates to be purchased, Figure 4.26.

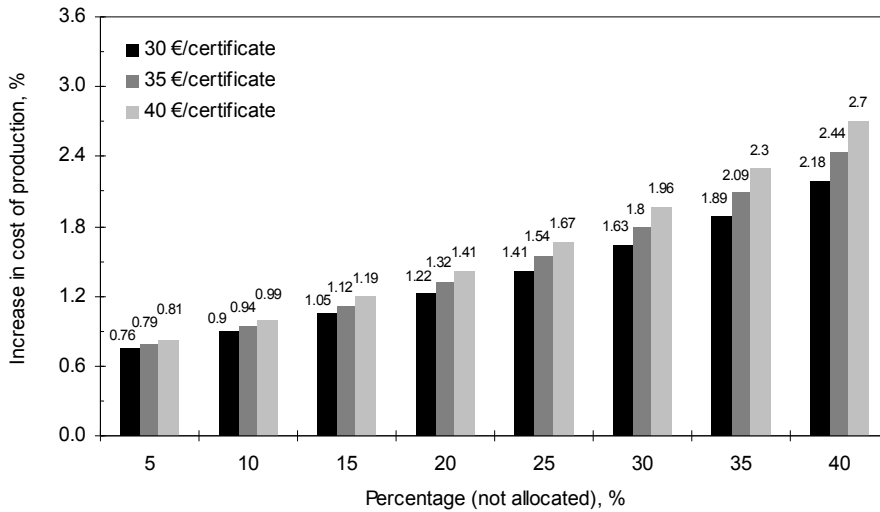

Figure 4.26. Impact of costs for purchasing and trading of allowances, in 2013, (Installation no. 4 – Case study 4)

Case study 5: For an average price of 35 €/certificate, there is an increase in cost of production (including electricity) between 1.66 and 1.95% in the range of 25-30% of needed certificates to be purchased, Figure 4.27.

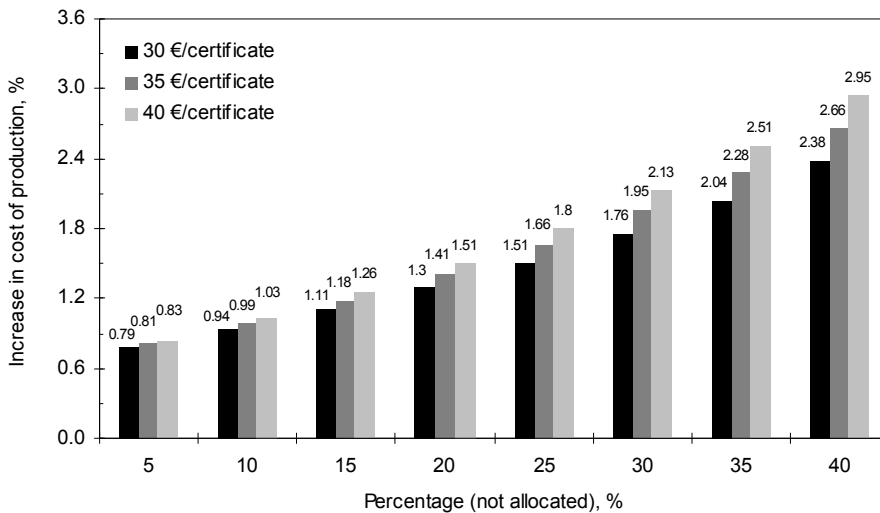

Figure 4.27. Impact of costs for purchasing and trading of allowances, in 2013, (Installation no. 4 – Case study 5)

For an average allowance price of 25 € with an investment of 1 million euros and if the reduction of fuel is more than 1.12%, then it is more profitable to make such investment than to purchase certificates with a price of 25 € per certificate, Figure 4.28.

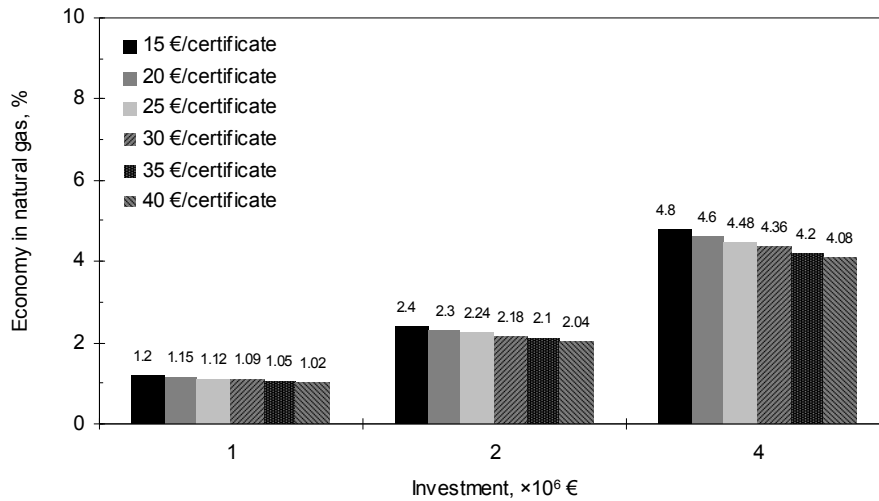

Figure 4.28. Investment in energy efficiency (Installation no. 4)

### 4.2.3 Mineral industry (cement, lime, glass and ceramic)

#### **Cement**

Installation no. 5, is a cement production unit.

Case study 0: Figure 4.29 shows that for a price of 20 €/certificate there is an increase in cost of production from 7.35% (when purchasing only 25% of needed certificates) to 9.23% (when purchasing 30% of needed certificates).

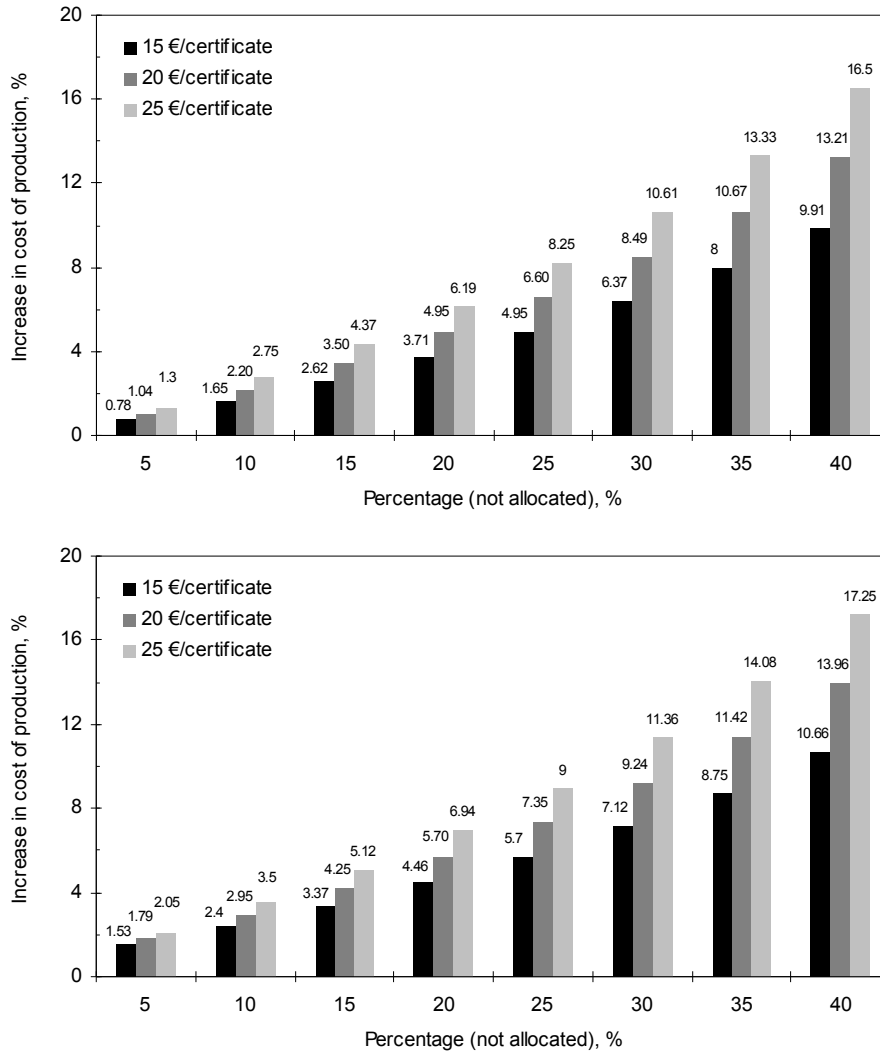

Figure 4.29. Impact of costs for purchasing and trading of allowances, in 2013, (top) without COE and (bottom) with COE, (Installation no. 5 – Case study 0)

For a mean situation of 25% of certificates purchased, the increase in cost of production becomes 7.35% compared to 6.6% from a previous value when the cost of electricity is not included.

Case study 1: For an average price of 20 €/certificate, there is an increase in cost of production (including electricity) between 10.68 and 13.52% in the range of 25-30% of needed certificates to be purchased, Figure 4.30.

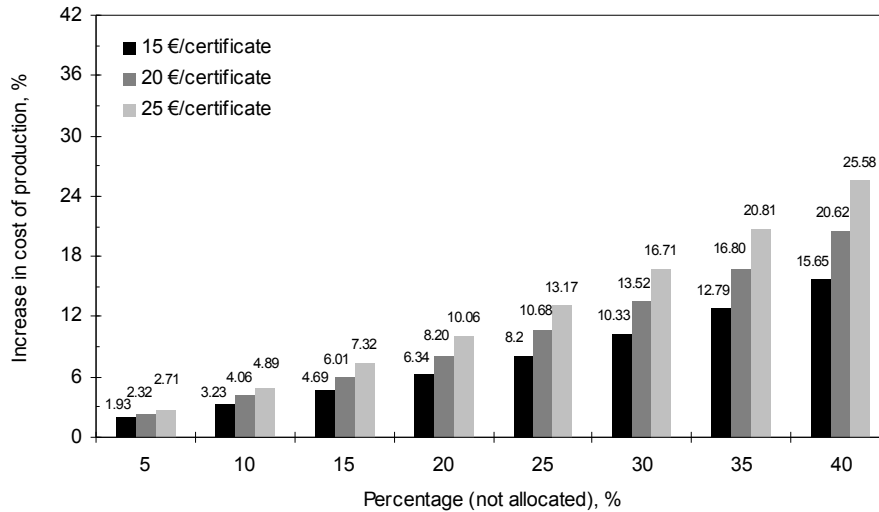

Figure 4.30. Impact of costs for purchasing and trading of allowances, in 2013, (Installation no. 5 – Case study 1)

It should be mentioned that, in this version, the average annual production for 2013 is at the production level from 2007 (increase 0). So, the share of ETS costs (including the increase in cost of electricity) is higher than in case study 0, which has an average increase of 50.47% for the period 2008-2012 in accordance with NAP.



Case study 2: For an average price of 20 €/certificate, there is an increase in cost of production (including electricity) between 9.78 and 12.36% in the range of 25-30% of needed certificates to be purchased, Figure 4.31.

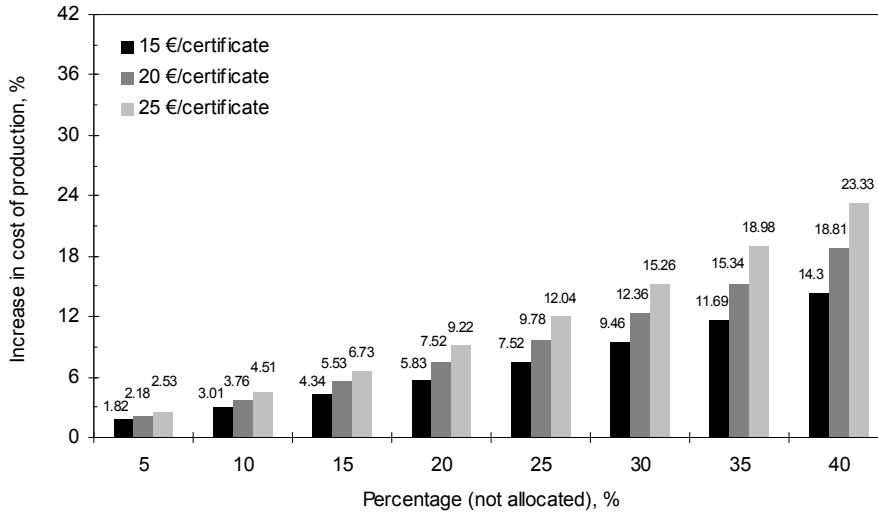

Figure 4.31. Impact of costs for purchasing and trading of allowances, in 2013, (Installation no. 5 – Case study 2)

Case study 3: For an average price of 35 €/certificate, there is an increase in cost of production (including electricity) between 12.3 and 15.6% in the range of 25-30% of needed certificates to be purchased, Figure 4.32.

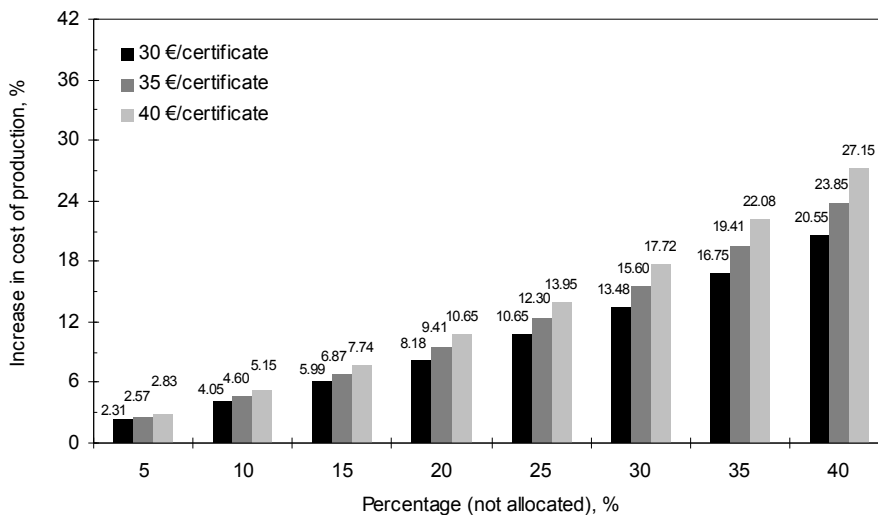

Figure 4.32. Impact of costs for purchasing and trading of allowances, in 2013, (Installation no. 5 – Case study 3)

Case study 4: For an average price of 35 €/certificate, there is an increase in cost of production (including electricity) between 18.13 and 23.1% in the range of 25-30% of needed certificates to be purchased, Figure 4.33.

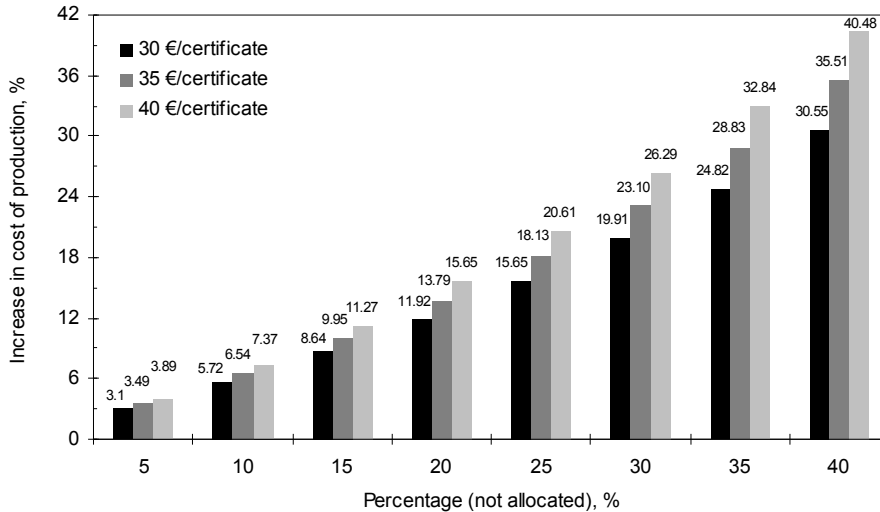

Figure 4.33. Impact of costs for purchasing and trading of allowances, in 2013, (Installation no. 5 – Case study 4)

Case study 5: For an average price of 35 €/certificate, there is an increase in cost of production (including electricity) between 15.8 and 20.32% in the range of 25-30% of needed certificates to be purchased, Figure 4.34.

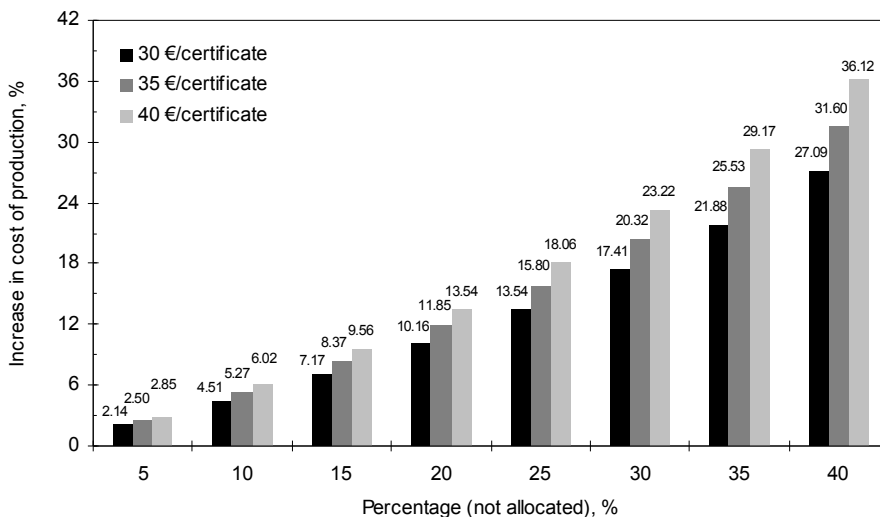

Figure 4.34. Impact of costs for purchasing and trading of allowances, in 2013, (Installation no. 5 – Case study 5)

Figure 4.35 shows the maximum level of investment, correlated with minimum fuel reduction, which leads to the decision to invest in projects for the energy efficiency improvement, for the six levels of allowance price (15-40 €/certificate).

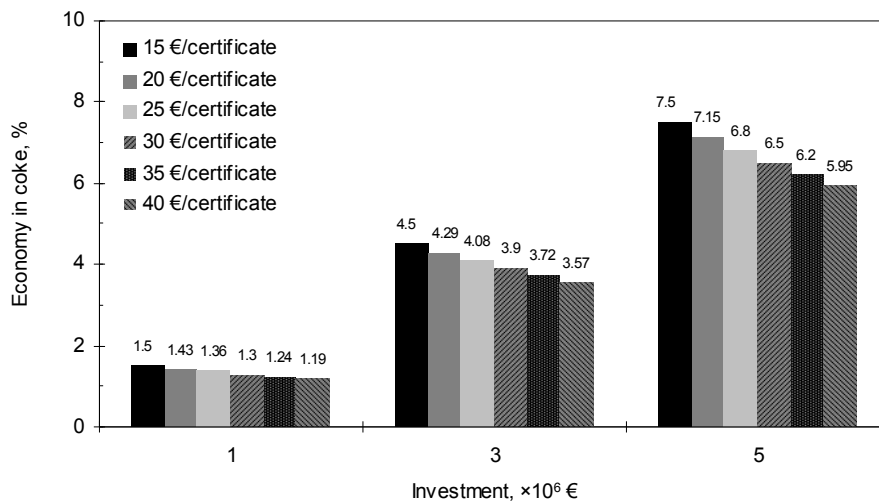

Figure 4.35. Investment in energy efficiency (Installation no. 5)

For instance, for an average allowance price of 25 € with an investment of 1 million euros and if the reduction of fuel is more than 1.36%, then it is more profitable to make such an investment than to purchase certificates with a price of 25 € per certificate.

### **Lime**

Installation no. 6, is a lime production unit.

Case study 0: For a price of 20 €/certificate there is an increase in cost of production from 6.63% (when purchasing 25% of needed certificates) to 8.49% (when purchasing 30% of needed certificates) as shown in Figure 4.36.

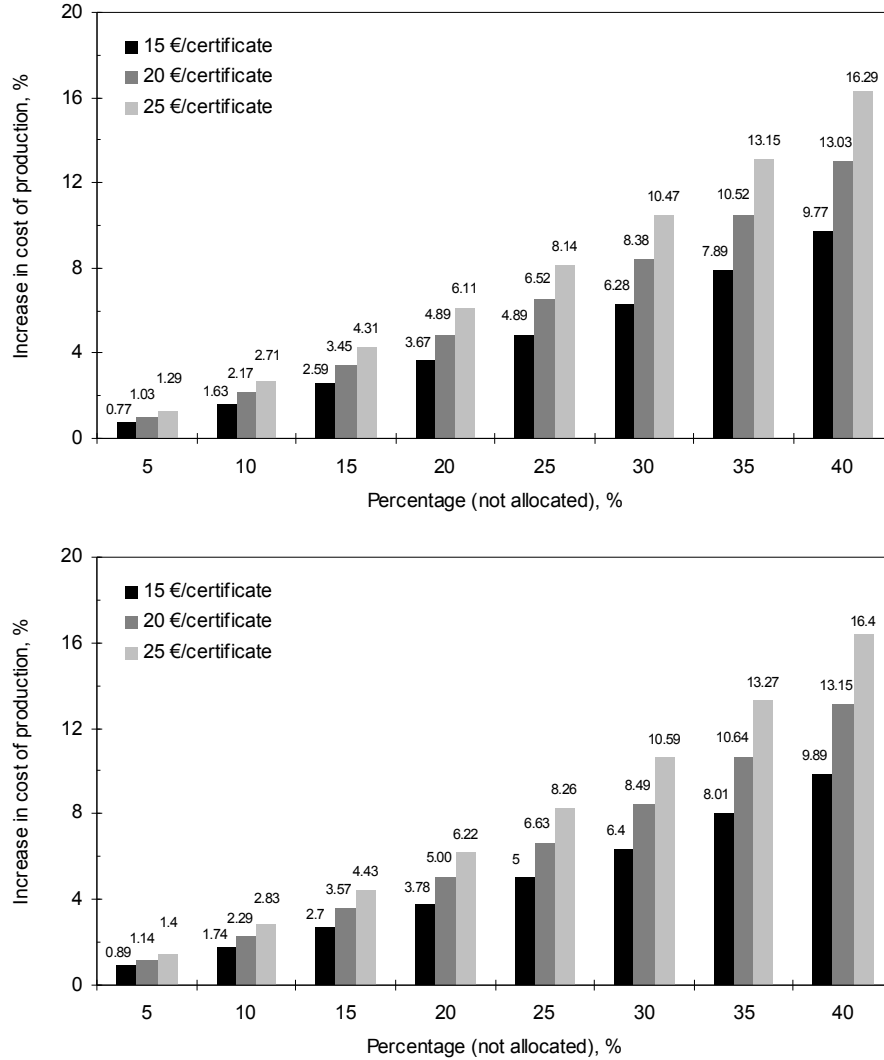

Figure 4.36. Impact of costs for purchasing and trading of allowances, in 2013, (top) without COE and (bottom) with COE, (Installation no. 6 – Case study 0)

For a mean of 25% of certificates purchased, the increase in cost of production becomes 6.63% compared to 6.52% of the situation when the cost of electricity is not included.

Case study 1: For an average price of 20 €/certificate, there is an increase in cost of production (including electricity) between 8.08 and 10.35% in the range of 25-30% of needed certificates to be purchased, Figure 4.37.

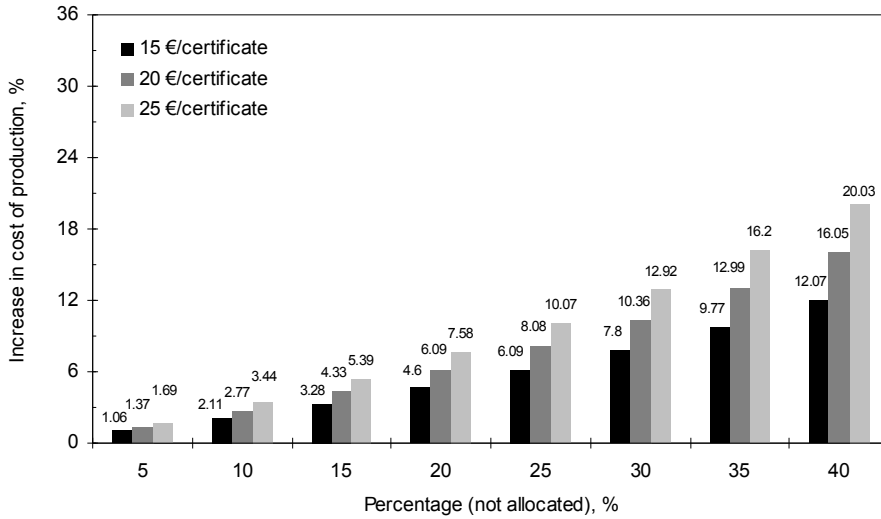

Figure 4.37. Impact of costs for purchasing and trading of allowances, in 2013, (Installation no. 6 – Case study 1)

Case study 2: For an average price of 20 €/certificate, there is an increase in cost of production (including electricity) between 7.36 and 9.43% in the range of 25-30% of needed certificates to be purchased, Figure 4.38.

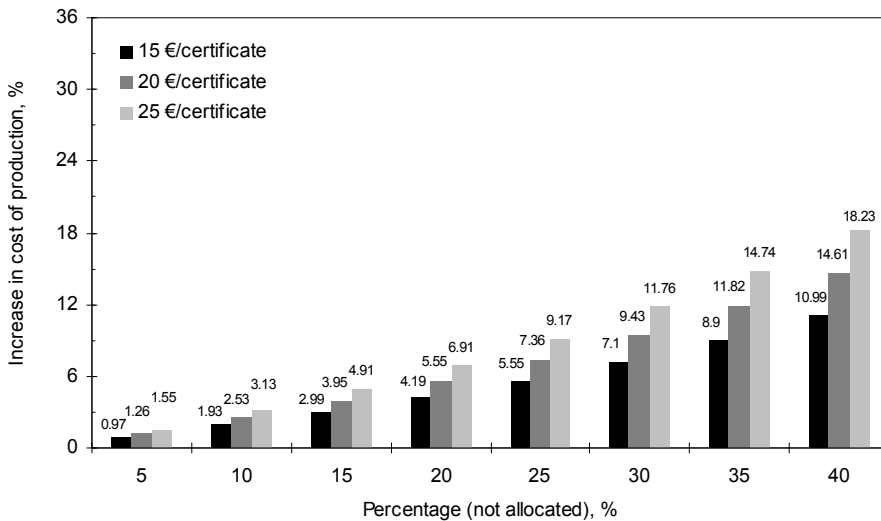

Figure 4.38. Impact of costs for purchasing and trading of allowances, in 2013, (Installation no. 6 – Case study 2)

Case study 3: For an average price of 35 €/certificate, there is an increase in cost of production (including electricity) between 11.51 and 14.77% in the range of 25-30% of needed certificates to be purchased, Figure 4.39.

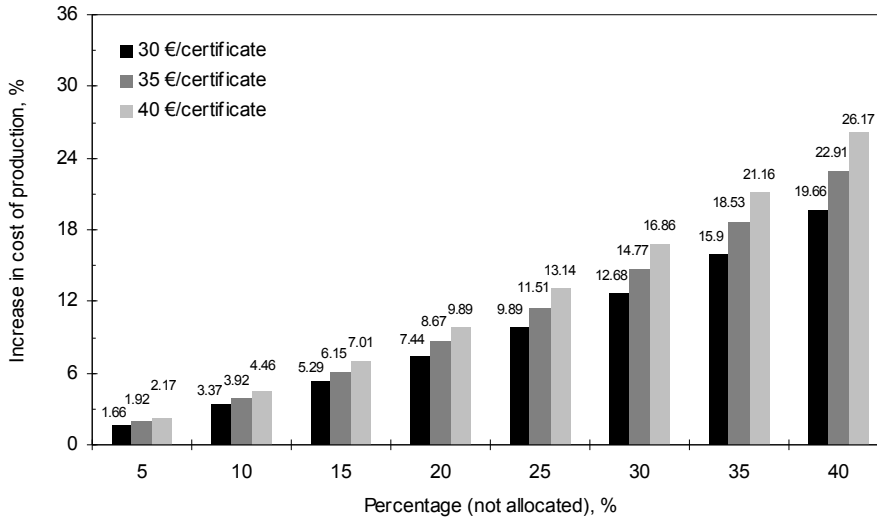

Figure 4.39. Impact of costs for purchasing and trading of allowances, in 2013, (Installation no. 6 – Case study 3)

Case study 4: For an average price of 35 €/certificate, there is an increase in cost of production (including electricity) between 14.05 and 18.04% in the range of 25-30% of needed certificates to be purchased, Figure 4.40.

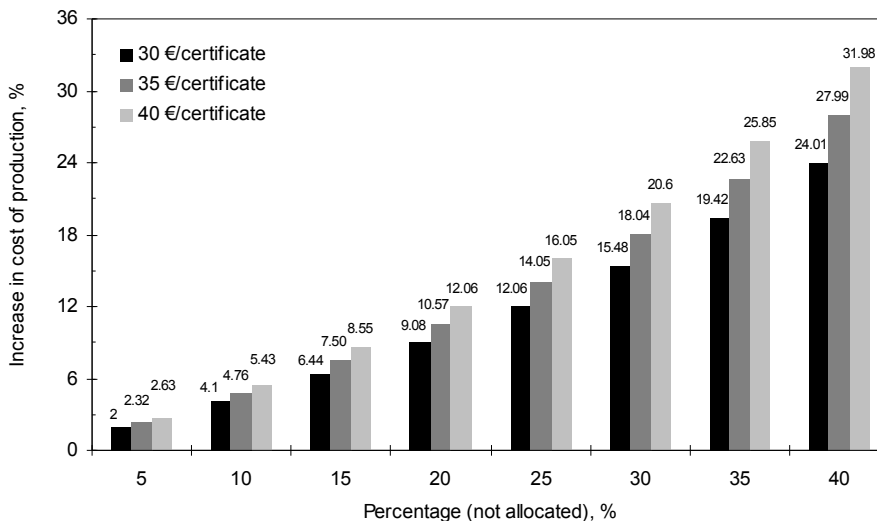

Figure 4.40. Impact of costs for purchasing and trading of allowances, in 2013, (Installation no. 6 – Case study 4)

Case study 5: For an average price of 35 €/certificate, there is an increase in cost of production (including electricity) between 12.67 and 16.29% in the range of 25-30% of needed certificates to be purchased, Figure 4.41.

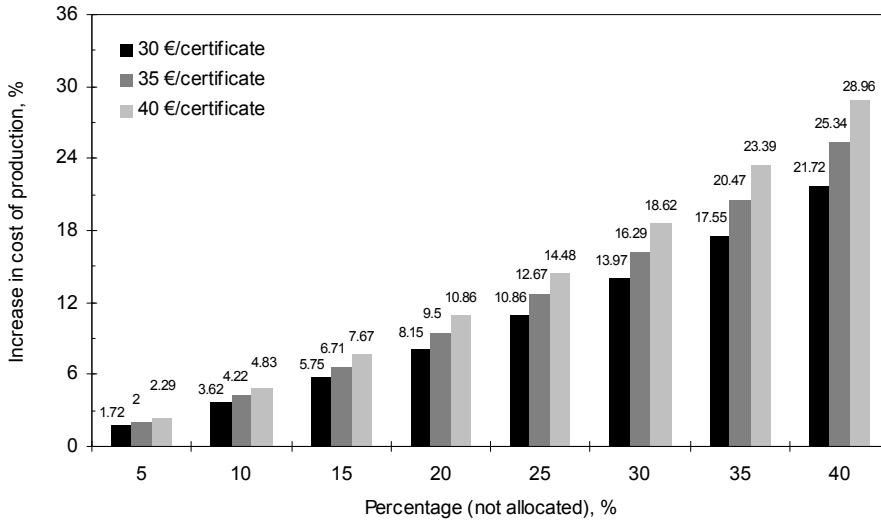

Figure 4.41. Impact of costs for purchasing and trading of allowances, in 2013, (Installation no. 6 – Case study 5)

Figure 4.42 shows the maximum level of investment, correlated with minimum fuel reduction, which leads to the decision to invest in projects for the energy efficiency improvement, for the six levels of allowance price (15-40 €/certificate).

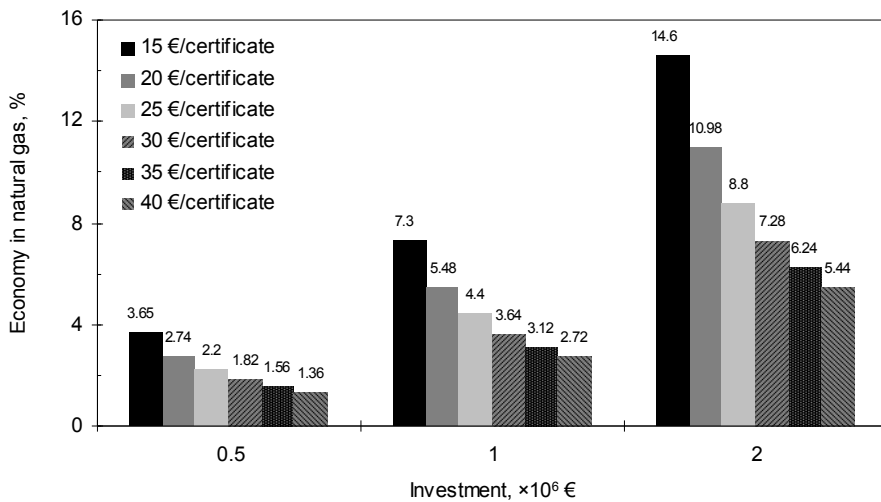

Figure 4.42. Investment in energy efficiency (Installation no. 6)

For instance, for an average allowance price of 25 € with an investment of 0.5 million euros and if the reduction of fuel is more than 2.2%, then it is more profitable to make such an investment than to purchase certificates with a price of 25 € per certificate.

### Glass

Installation no. 7, is designed for glass production (including glass fibre).

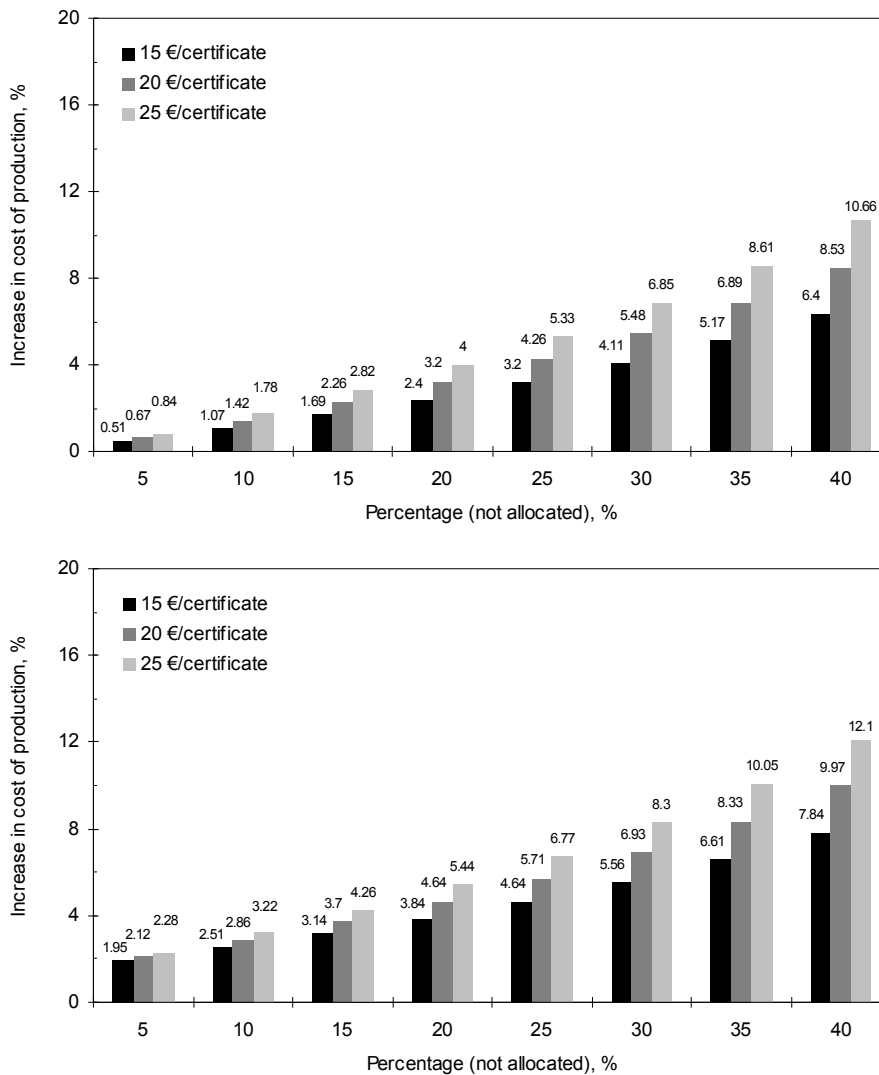

Figure 4.43. Impact of costs for purchasing and trading of allowances, in 2013, (top) without COE and (bottom) with COE, (Installation no. 7 – Case study 0)



Case study 0: For a price of 20 €/certificate there is an increase in cost of production from 5.71% (when purchasing 25% of needed certificates) to 6.93% (when purchasing 30% of needed certificates) as shown in Figure 4.43.

For a mean of 25% of certificates purchased, the increase in cost of production becomes 5.71% compared to 4.26% of the situation when the cost of electricity is not included.

Case study 1: For an average price of 20 €/certificate, there is an increase in cost of production (including electricity) between 6.26 and 7.64% in the range of 25-30% of needed certificates to be purchased, Figure 4.44.

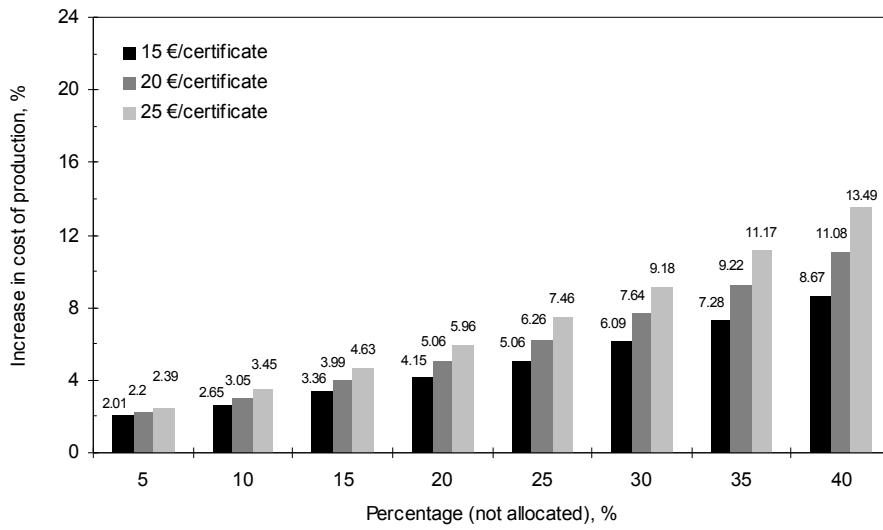

Figure 4.44. Impact of costs for purchasing and trading of allowances, in 2013, (Installation no. 7 – Case study 1)

Case study 2: For an average price of 20 €/certificate, there is an increase in cost of production (including electricity) between 6.78 and 8.3% in the range of 25-30% of needed certificates to be purchased, Figure 4.45.

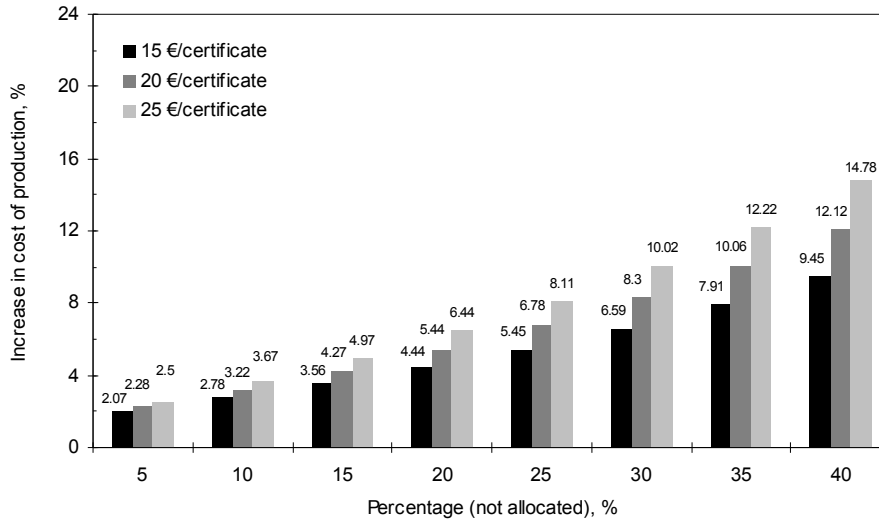

Figure 4.45. Impact of costs for purchasing and trading of allowances, in 2013, (Installation no. 7 – Case study 2)

Case study 3: For an average price of 35 €/certificate, there is an increase in cost of production (including electricity) between 8.9 and 11.04% in the range of 25-30% of needed certificates to be purchased, Figure 4.46.

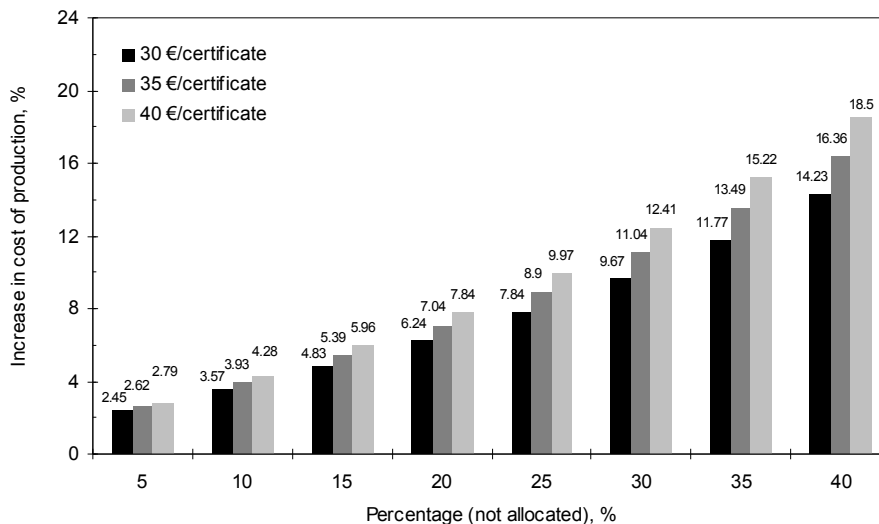

Figure 4.46. Impact of costs for purchasing and trading of allowances, in 2013, (Installation no. 7 – Case study 3)

Case study 4: For an average price of 35 €/certificate, there is an increase in cost of production (including electricity) between 9.87 and 12.28% in the range of 25-30% of needed certificates to be purchased, Figure 4.47.

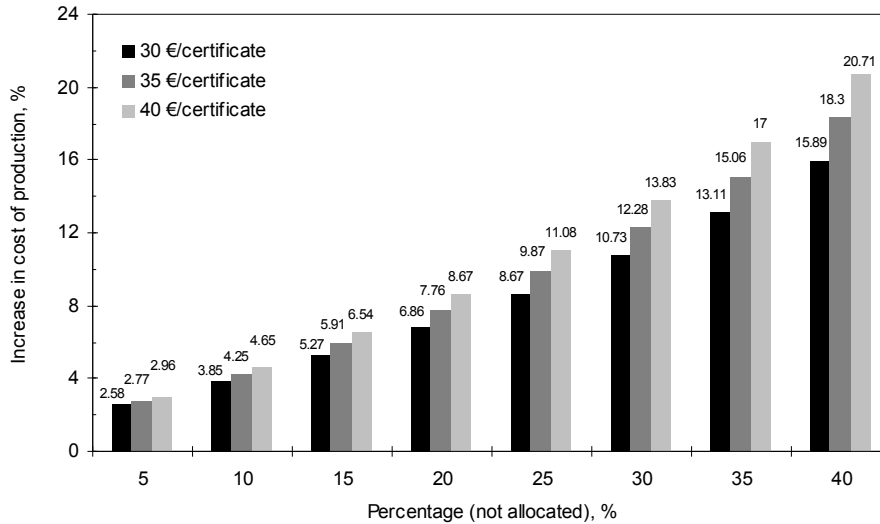

Figure 4.47. Impact of costs for purchasing and trading of allowances, in 2013, (Installation no. 7 – Case study 4)

Case study 5: For an average price of 35 €/certificate, there is an increase in cost of production (including electricity) between 9.34 and 12.01% in the range of 25-30% of needed certificates to be purchased, Figure 4.48.

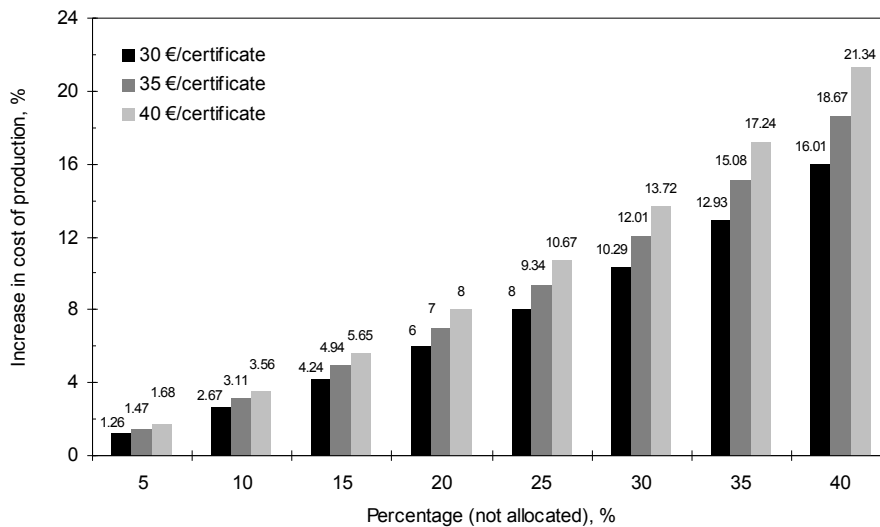

Figure 4.48. Impact of costs for purchasing and trading of allowances, in 2013, (Installation no. 7 – Case study 5)

Figure 4.49 shows the maximum level of investment, correlated with minimum fuel reduction, which leads to the decision to invest in projects for the energy efficiency improvement, for the six levels of allowance price (15-40 €/certificate).

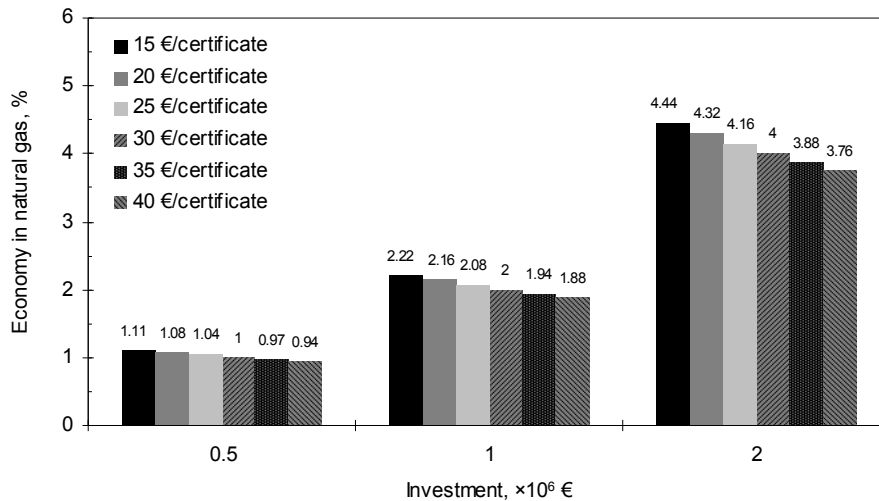

Figure 4.49. Investment in energy efficiency (Installation no. 7)

For instance, for an average allowance price of 25 € with an investment of 0.5 million euros and if the reduction of fuel is more than 1.04%, then it is more profitable to make such an investment than to purchase certificates with a price of 25 € per certificate.

### **Ceramic**

Installation no. 8, is designed for manufacture of ceramic products.

Case study 0: For a price of 20 €/certificate there is an increase in cost of production from 0.84% (when purchasing 25% of needed certificates) to 1.04% (when purchasing 30% of needed certificates) as shown in Figure 4.50.

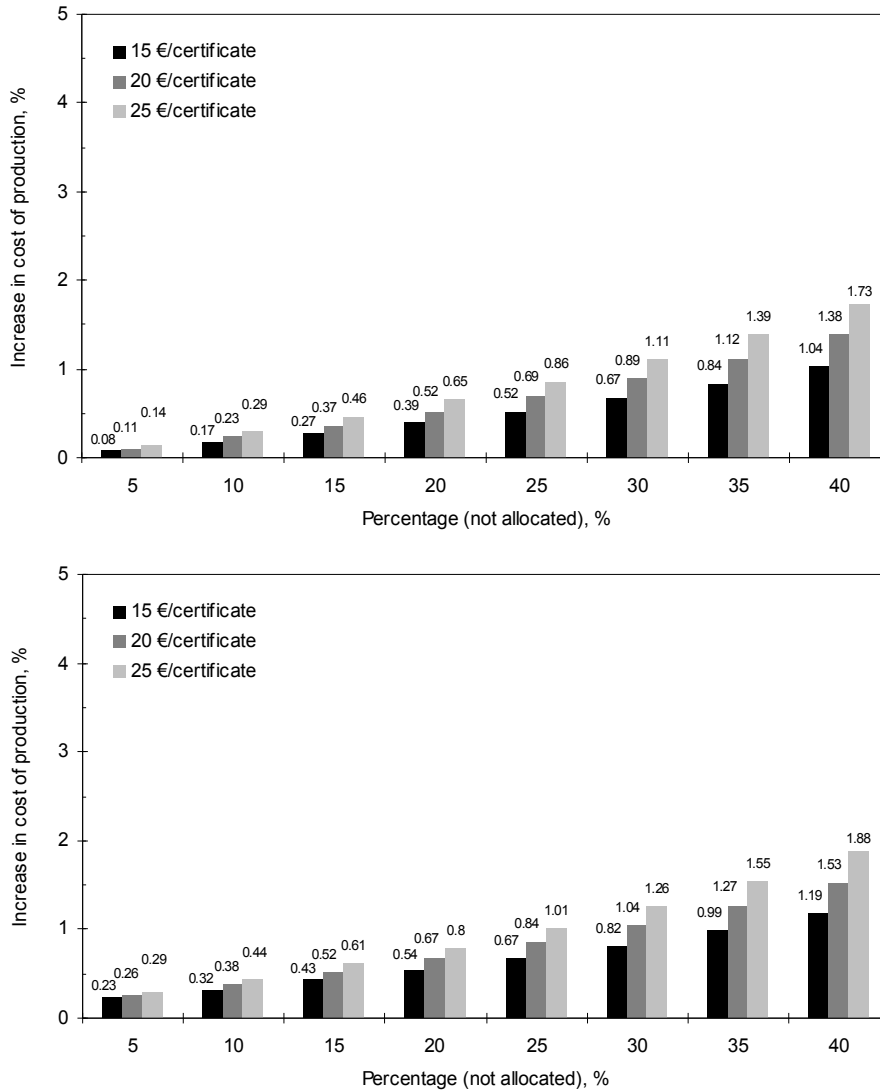

Figure 4.50. Impact of costs for purchasing and trading of allowances, in 2013, (top) without COE and (bottom) with COE, (Installation no. 8 – Case study 0)

For a mean of 25% of certificates purchased, the increase in cost of production becomes 0.8% compared to 0.7% of the previous situation when the cost of electricity is not included.

Case study 1: For an average price of 20 €/certificate, there is an increase in cost of production (including electricity) between 0.97 and 1.21% in the range of 25-30% of needed certificates to be purchased, Figure 4.51.

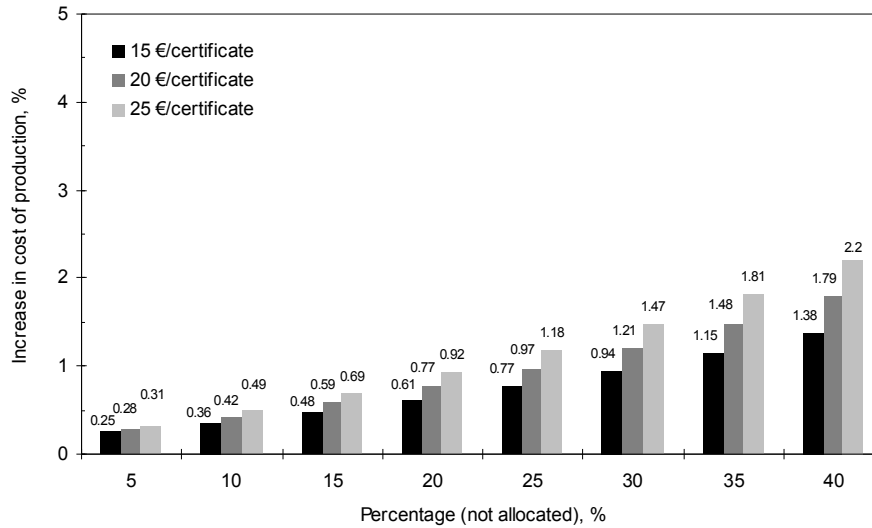

Figure 4.51. Impact of costs for purchasing and trading of allowances, in 2013, (Installation no. 8 – Case study 1)

Case study 2: For an average price of 20 €/certificate, there is an increase in cost of production (including electricity) between 1.07 and 1.33% in the range of 25-30% of needed certificates to be purchased, Figure 4.52.

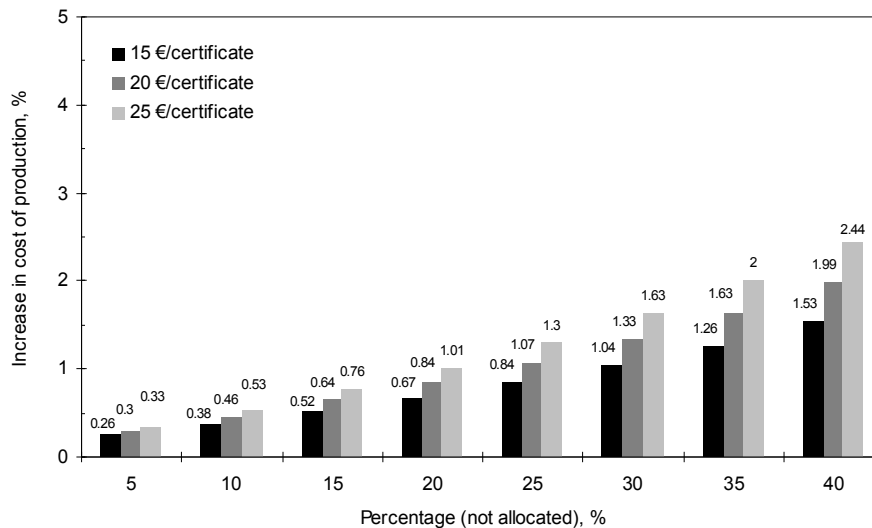

Figure 4.52. Impact of costs for purchasing and trading of allowances, in 2013, (Installation no. 8 – Case study 2)

Case study 3: For an average price of 35 €/certificate, there is an increase in cost of production (including electricity) between 1.36 and 1.7% in the range of 25-30% of needed certificates to be purchased, Figure 4.53.

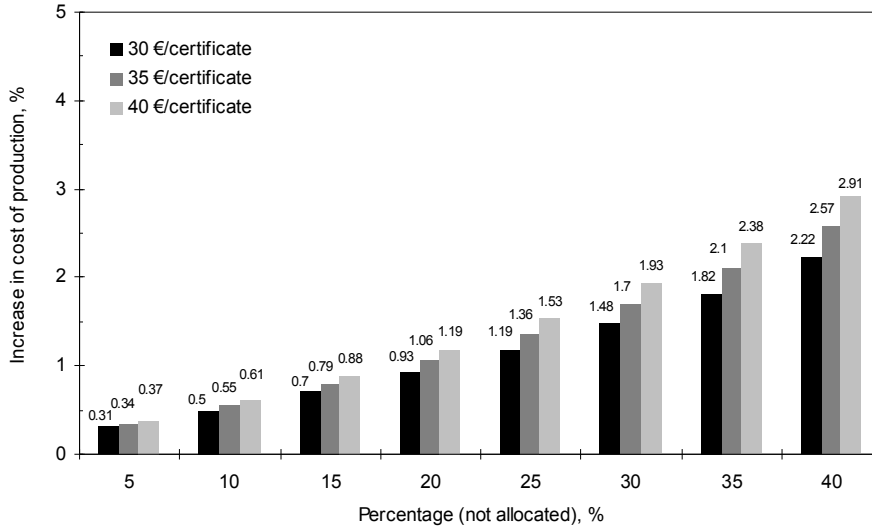

Figure 4.53. Impact of costs for purchasing and trading of allowances, in 2013, (Installation no. 8 – Case study 3)

Case study 4: For an average price of 35 €/certificate, there is an increase in cost of production (including electricity) between 1.59 and 2% in the range of 25-30% of needed certificates to be purchased, Figure 4.54.

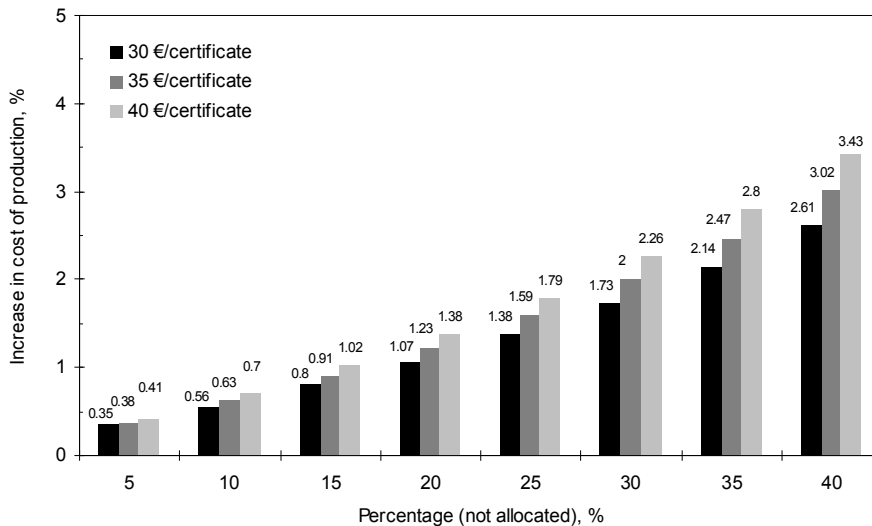

Figure 4.54. Impact of costs for purchasing and trading of allowances, in 2013, (Installation no. 8 – Case study 4)

Case study 5: For an average price of 35 €/certificate, there is an increase in cost of production (including electricity) between 1.76 and 2.21% in the range of 25-30% of needed certificates to be purchased, Figure 4.55.

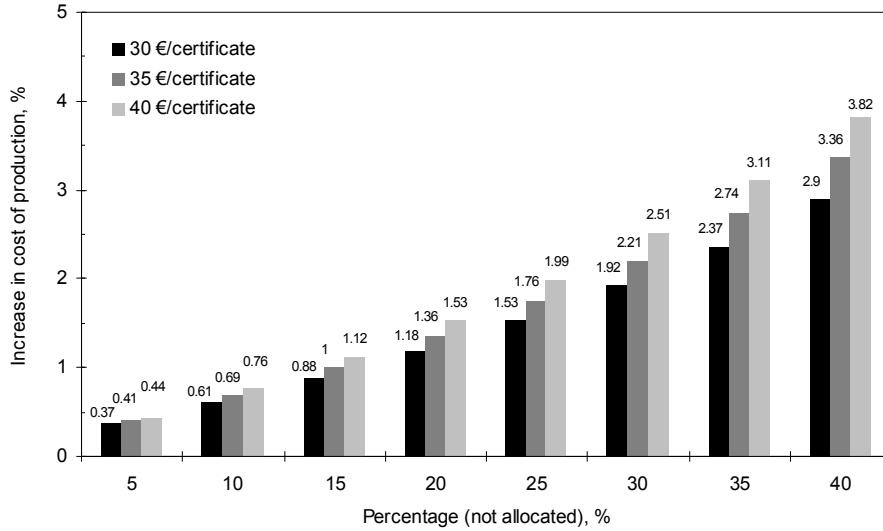

Figure 4.55. Impact of costs for purchasing and trading of allowances, in 2013, (Installation no. 8 – Case study 5)

Figure 4.56 shows the maximum level of investment.

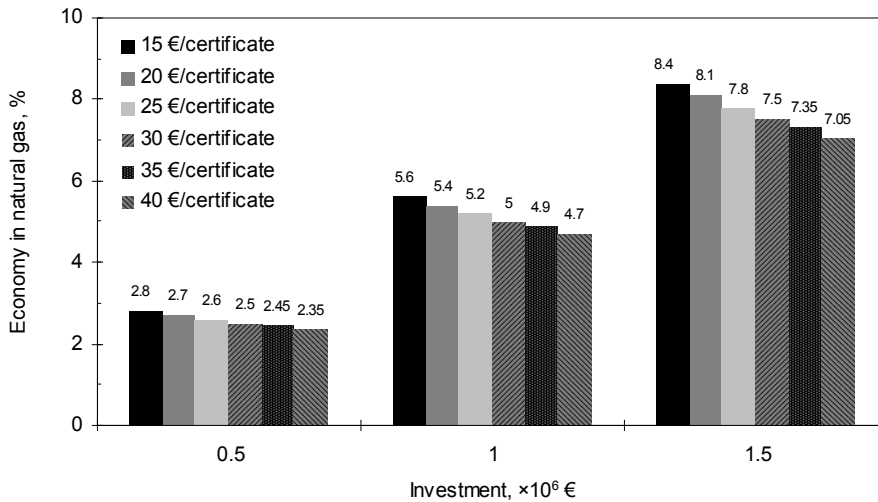

Figure 4.56. Investment in energy efficiency (Installation no. 8)

For an average allowance price of 25 € with an investment of 0.5 million euros and if the reduction of fuel is more than 2.6%, then it is more profitable to



make such an investment than to purchase certificates with a price of 25 € per certificate.

#### 4.2.4 Pulp and paper

Installation no. 9, is a unit for the production of paper and pulp.

Case study 0: For a price of 20 €/certificate there is an increase in cost of production from 1.58% (when purchasing 25% of needed certificates) to 1.87% (when purchasing 30% of needed certificates) as shown in Figure 4.57.

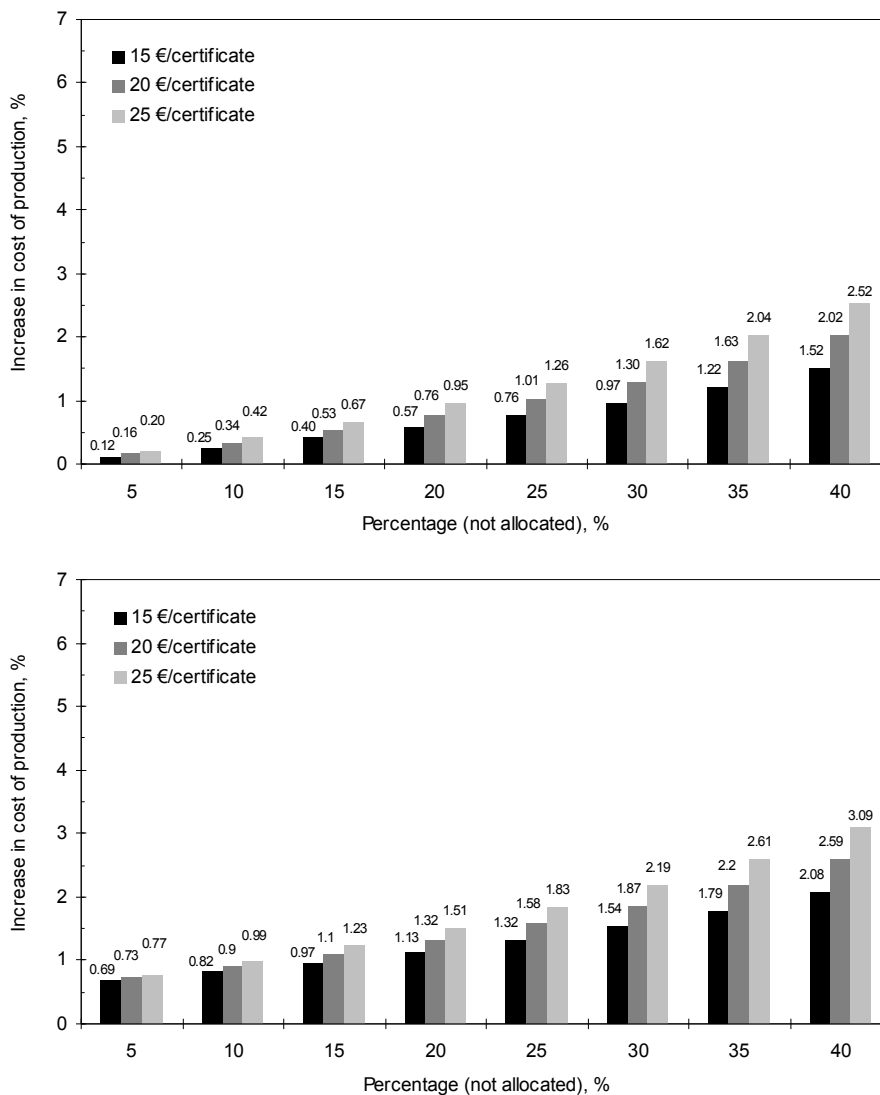

Figure 4.57. Impact of costs for purchasing and trading of allowances, in 2013, (top) without COE and (bottom) with COE, (Installation no. 9 – Case study 0)

For a mean of 20% of certificates purchased, the increase in cost of production becomes 1.32% compared to 0.76% of the situation when the cost of electricity is not included.

Case study 1: For an average price of 20 €/certificate, there is an increase in cost of production (including electricity) between 1.86 and 2.23% in the range of 25-30% of needed certificates to be purchased, Figure 4.58.

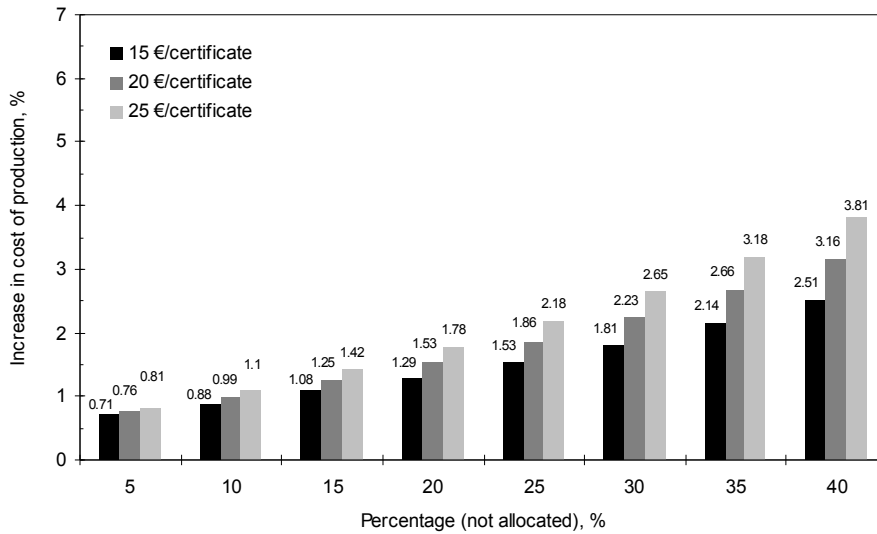

Figure 4.58. Impact of costs for purchasing and trading of allowances, in 2013, (Installation no. 9 – Case study 1)

Case study 2: For an average price of 20 €/certificate, there is an increase in cost of production (including electricity) between 2.03 and 2.45% in the range of 25-30% of needed certificates to be purchased, Figure 4.59.

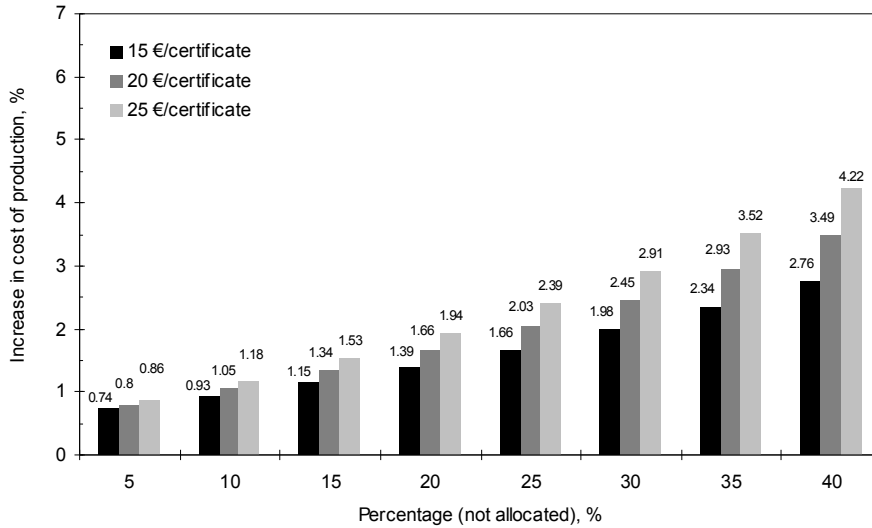

Figure 4.59. Impact of costs for purchasing and trading of allowances, in 2013, (Installation no. 9 – Case study 2)

Case study 3: For an average price of 35 €/certificate, there is an increase in cost of production (including electricity) between 2.33 and 2.84% in the range of 25-30% of needed certificates to be purchased, Figure 4.60.

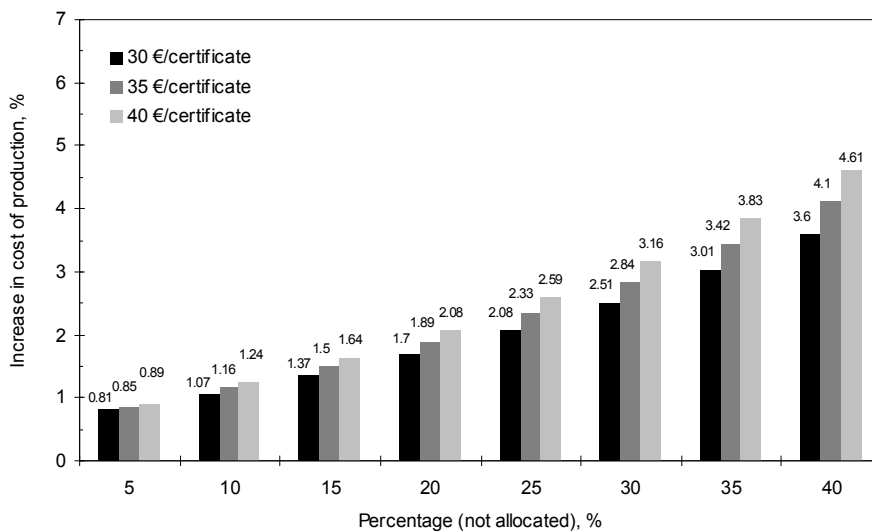

Figure 4.60. Impact of costs for purchasing and trading of allowances, in 2013, (Installation no. 9 – Case study 3)

Case study 4: For an average price of 35 €/certificate, there is an increase in cost of production (including electricity) between 2.83 and 3.48% in the range of 25-30% of needed certificates to be purchased, Figure 4.61.

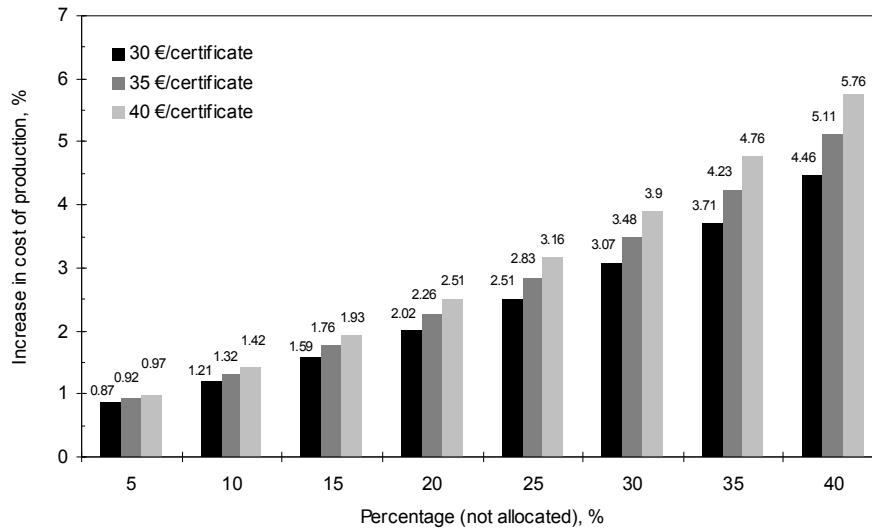

Figure 4.61. Impact of costs for purchasing and trading of allowances, in 2013, (Installation no. 9 – Case study 4)

Case study 5: For an average price of 35 €/certificate, there is an increase in cost of production (including electricity) between 3.12 and 3.85% in the range of 25-30% of needed certificates to be purchased, Figure 4.62.

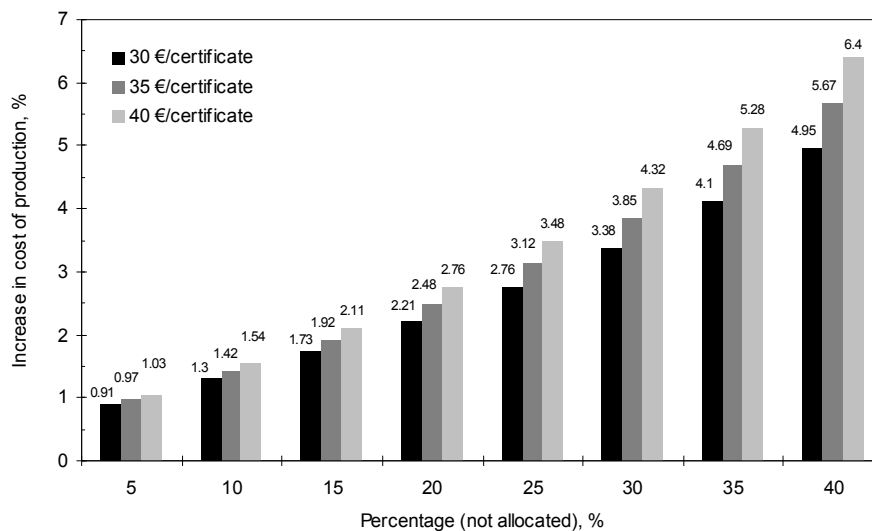

Figure 4.62. Impact of costs for purchasing and trading of allowances, in 2013, (Installation no. 9 – Case study 5)

Figure 4.63 shows the maximum level of investment in case of Installation no. 9.

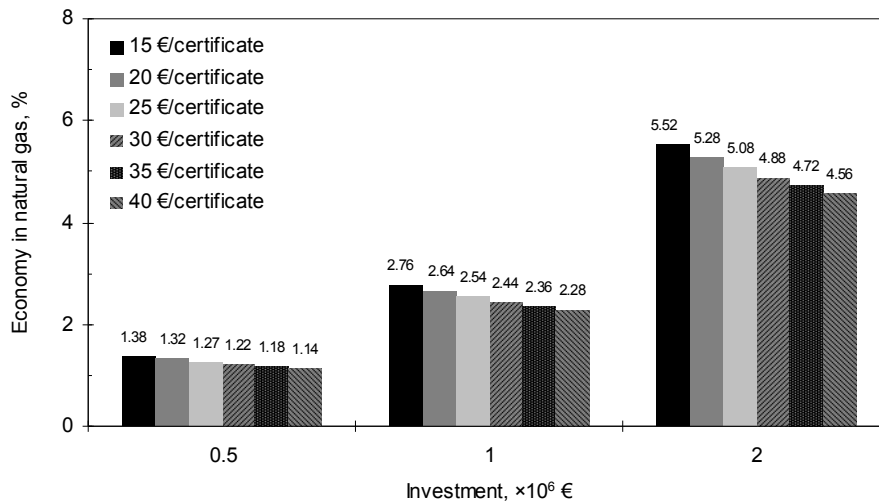

Figure 4.63. Investment in energy efficiency (Installation no. 9)

For instance, for an average allowance price of 25 € with an investment of 0.5 million euros and if the reduction of fuel is more than 1.27%, then it is more profitable to make such an investment than to purchase certificates with a price of 25 € per certificate.

#### 4.2.5 Energy and lime

Installation no. 10, it represents a production unit that makes part of NAP at the energy and lime sector. Additional activities will be included in the trading scheme after 2012.

Case study 0: For a price of 20 €/certificate there is an increase in cost of production from 0.5% (when purchasing 25% of needed certificates) to 0.62% (when purchasing 30% of needed certificates) as shown in Figure 4.64.

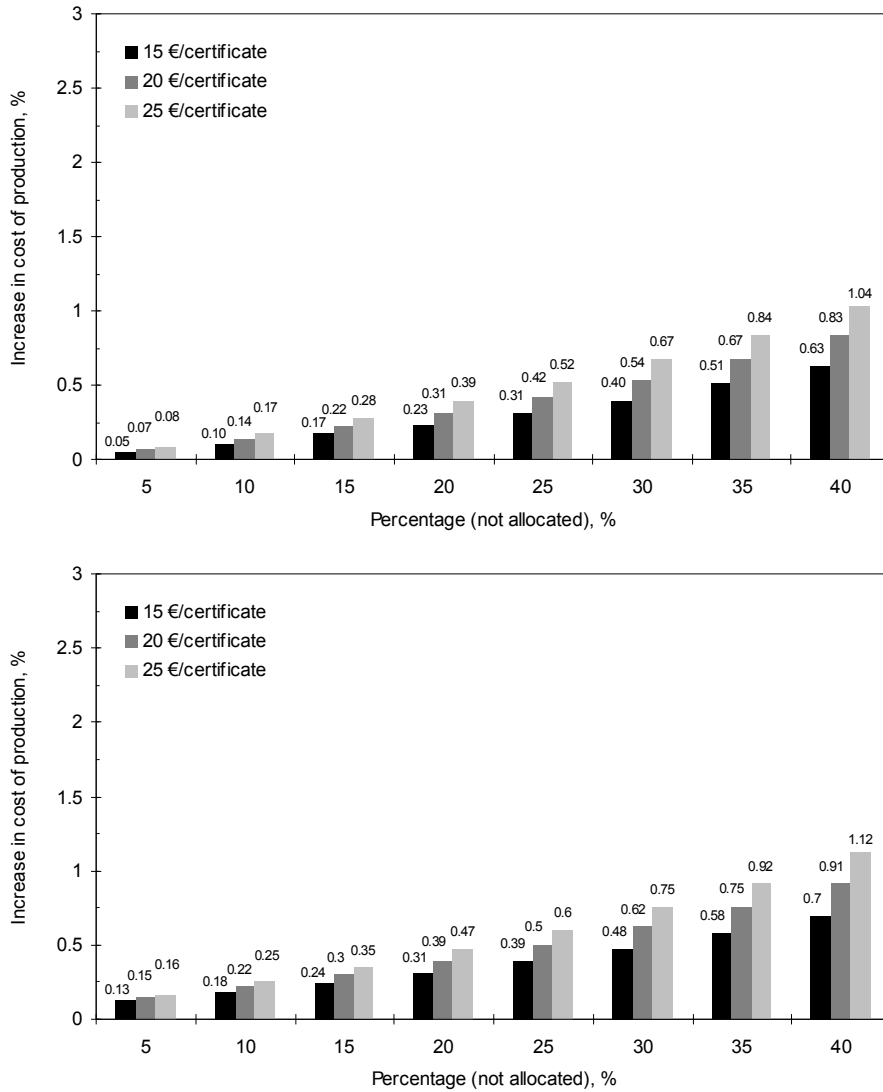

Figure 4.64. Impact of costs for purchasing and trading of allowances, in 2013, (top) without COE and (bottom) with COE, (Installation no. 10 – Case study 0)

For a mean of 25% of certificates purchased, the increase in cost of production becomes 0.5% compared to 0.42% of the situation when the cost of electricity is not included.

Case study 1: For an average price of 20 €/certificate, there is an increase in cost of production (including electricity) between 0.66 and 0.83% in the range of 25-30% of needed certificates to be purchased, Figure 4.65.

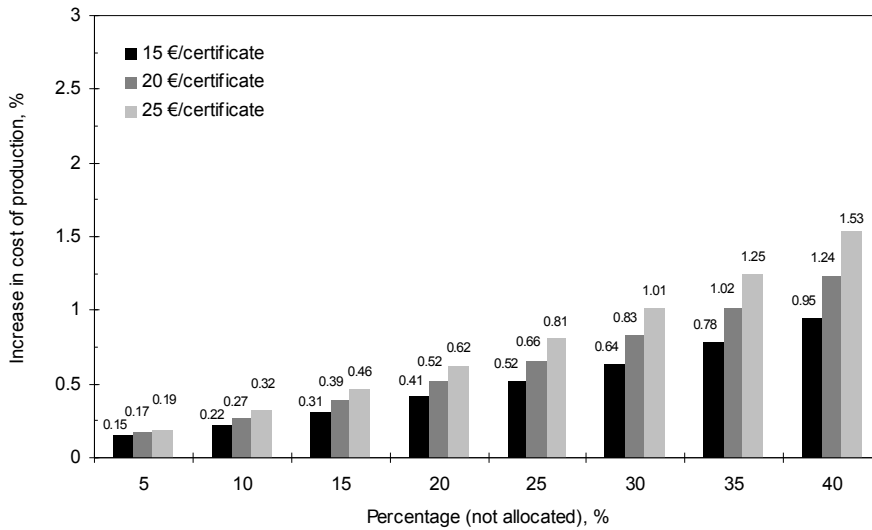

Figure 4.65. Impact of costs for purchasing and trading of allowances, in 2013, (Installation no. 10 – Case study 1)

Case study 2: For an average price of 20 €/certificate, there is an increase in cost of production (including electricity) between 0.72 and 0.91% in the range of 25-30% of needed certificates to be purchased, Figure 4.66.

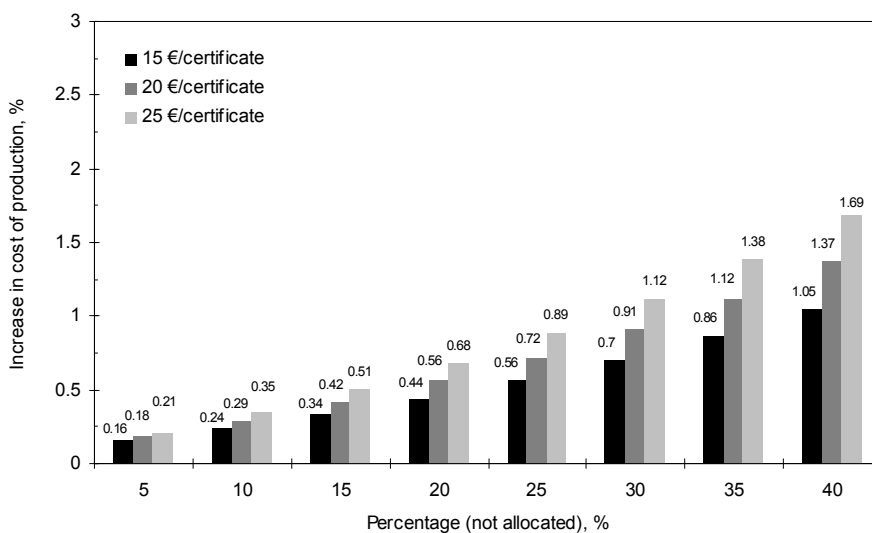

Figure 4.66. Impact of costs for purchasing and trading of allowances, in 2013, (Installation no. 10 – Case study 2)

Case study 3: For an average price of 35 €/certificate, there is an increase in cost of production (including electricity) between 0.81 and 1.02% in the range of 25-30% of needed certificates to be purchased, Figure 4.67.

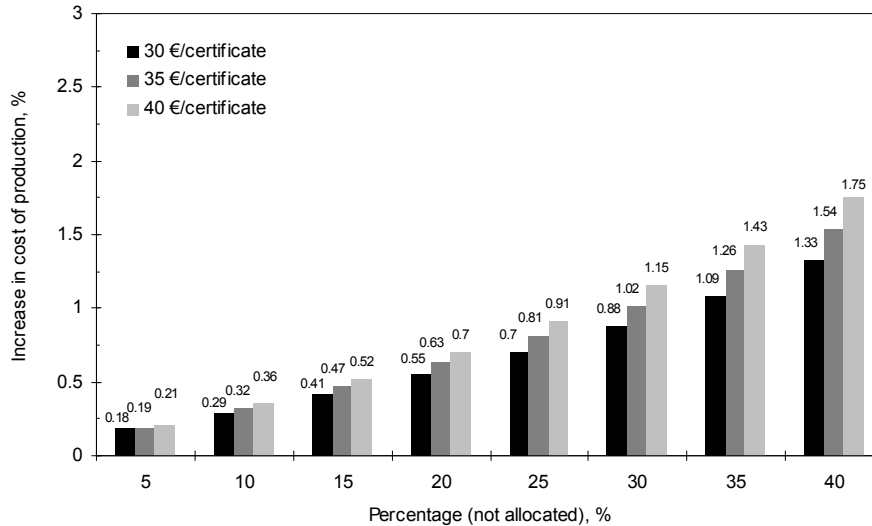

Figure 4.67. Impact of costs for purchasing and trading of allowances, in 2013, (Installation no. 10 – Case study 3)

Case study 4: For an average price of 35 €/certificate, there is an increase in cost of production (including electricity) between 1.1 and 1.39% in the range of 25-30% of needed certificates to be purchased, Figure 4.68.

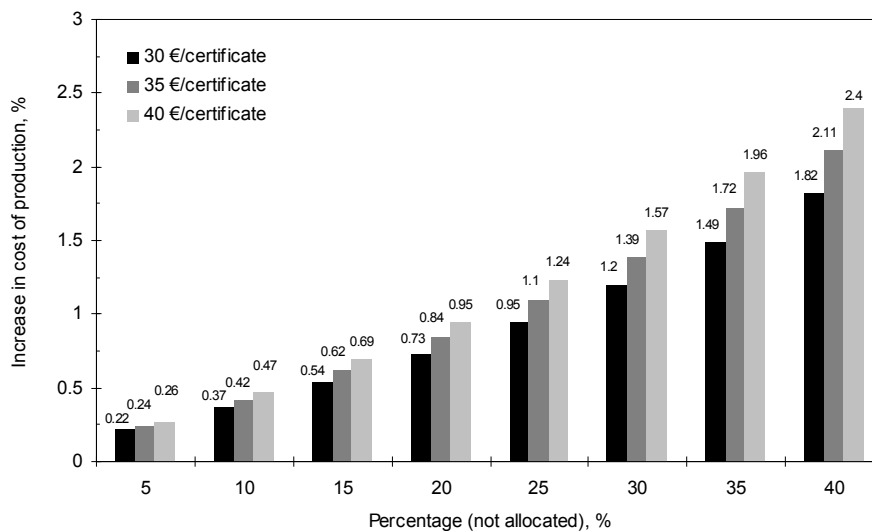

Figure 4.68. Impact of costs for purchasing and trading of allowances, in 2013, (Installation no. 10 – Case study 4)



Case study 5: For an average price of 35 €/certificate, there is an increase in cost of production (including electricity) between 1.21 and 1.53% in the range of 25-30% of needed certificates to be purchased, Figure 4.69.

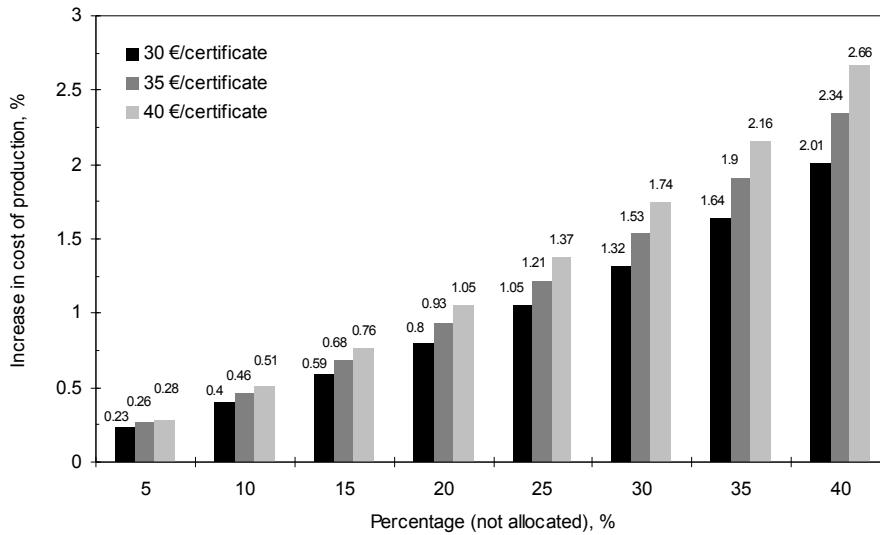

Figure 4.69. Impact of costs for purchasing and trading of allowances, in 2013, (Installation no. 10 – Case study 5)

The maximum level of investment for Installation no. 10 is presented in Figure 4.70.

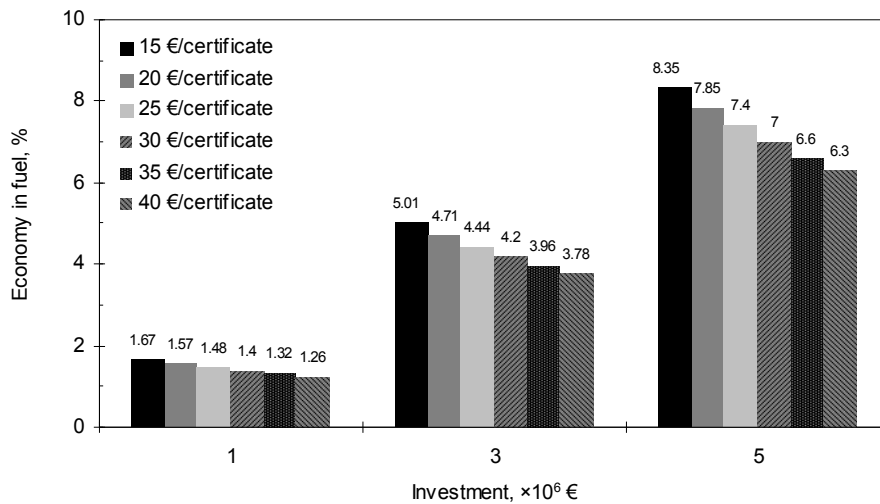

Figure 4.70. Investment in energy efficiency (Installation no. 10)

For instance, for an average allowance price of 25 € with an investment of 1 million euros and if the reduction of fuel is more than 1.48%, then it is more profitable to make such an investment than to purchase certificates with a price of 25 € per certificate.

#### 4.2.6 Chemical industry

Installation no. 11 is currently covered by the ETS for the period 2008-2012, to which new activities are added from 2013.

Case study 1: For an average price of 20 €/certificate, there is an increase in cost of production (including electricity) between 7.14 and 9.03% in the range of 25-30% of needed certificates to be purchased, Figure 4.71.

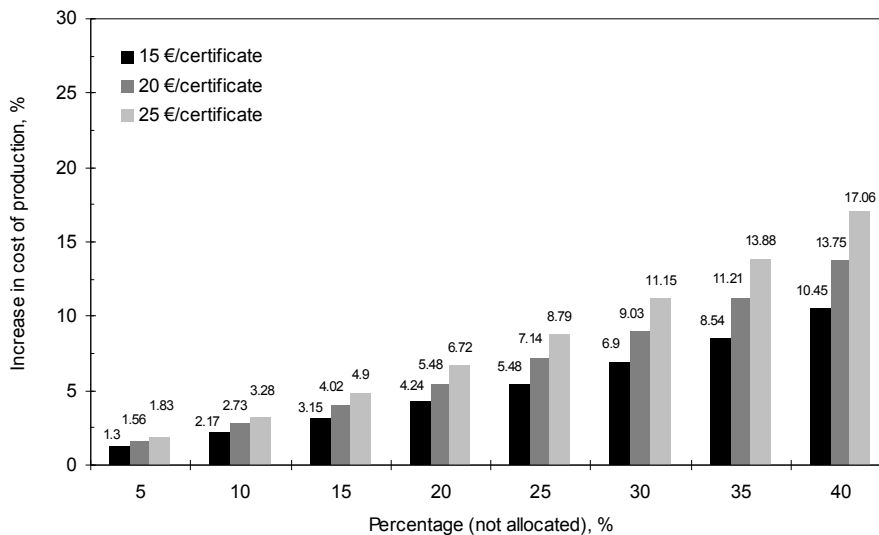

Figure 4.71. Impact of costs for purchasing and trading of allowances, in 2013, (Installation no. 11 – Case study 1)

Case study 4: For an average price of 35 €/certificate, there is an increase in cost of production (including electricity) between 12.1 and 15.4% in the range of 25-30% of needed certificates to be purchased, Figure 4.72.

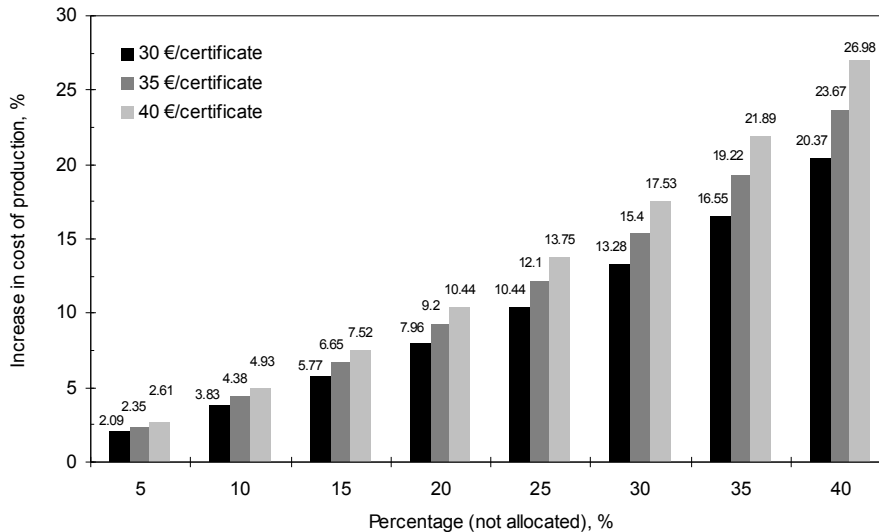

Figure 4.72. Impact of costs for purchasing and trading of allowances, in 2013, (Installation no. 11 – Case study 4)

#### 4.2.7 Non-ferrous metals

Representative installation no. 12 is not included in the trading scheme for the period 2008-2012, it should be included in the ETS in 2013.

Case study 1: For an average price of 20 €/certificate, there is an increase in cost of production (including electricity) between 5.56 and 6.94% in the range of 25-30% of needed certificates to be purchased, Figure 4.73.

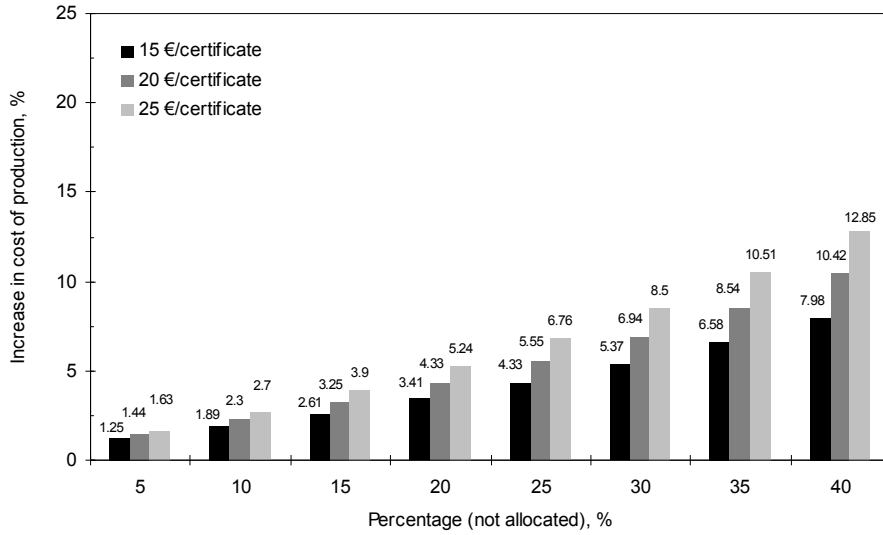

Figure 4.73. Impact of costs for purchasing and trading of allowances, in 2013, (Installation no. 12 – Case study 1)

Case study 4: For an average price of 35 €/certificate, there is an increase in cost of production (including electricity) between 9.2 and 11.63% in the range of 25-30% of needed certificates to be purchased, Figure 4.74.

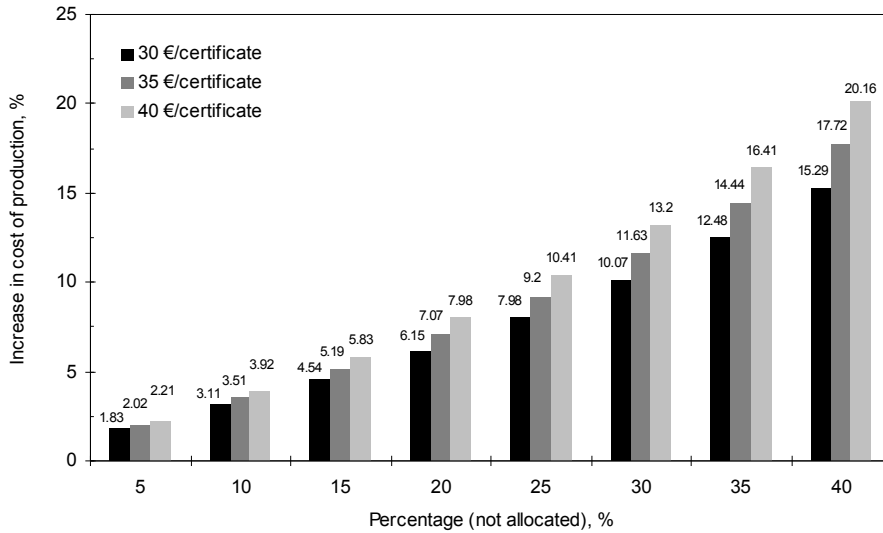

Figure 4.74. Impact of costs for purchasing and trading of allowances, in 2013, (Installation no. 12 – Case study 4)

## 5 Impact of the ETS costs on industrial activities in 2013

This chapter presents the influence of additional costs on industrial activities in 2013, namely there are analyzed their effect on the profit and on the increase of the selling price of products.

Calculations have been performed under the same assumptions as in the previous chapter: (i) analysis is done for 2013, the first year in which the new climate-energy legislative package enters into the force; (ii) selected installations for existing and new ETS industrial sectors are the only ones which accepted to collaborate and provide data necessary for this study (rest of the data were estimated); (iii) for 2013 the industrial production, costs and revenues are considered the same as those for the period 2008-2012. This assumption was considered because industrial operators who responded to the questionnaire did overestimated the indicators; (iv) allocation of the allowances: there have been considered the levels of allocation deficit of 5-40%; (v) allowance price: for 2013, it is considered a price ranging between 15 and 40 € per certificate; (vi) rate of profit was communicated by operators; (vii) in order to set the ceiling for 2013 as well as the share of emission allowances that will be available free of charge, there were taken into account both Directive 2009/29/EC [E2] and the Commission decision [E7] that contains a list of sectors and subsectors which are deemed to be exposed to a significant risk of carbon leakage.

Table 5.1 shows the impact of the climate-energy legislative package on industrial activities covered by emission trading scheme. It can be noted the following:

- Concerning the profit: (i) as industrial production increases, for the same allowance price and the same amount of allowances not allocated, the profit decreases; (ii) as the quantity of purchased allowances increases, for the same allowance price, the profit decreases (i.e., purchasing more allowances will lead to the reduction in profit); (iii) as allowance price increases, for the same amount of purchased allowances and the same production Case study, the profit decreases;
- Concerning the selling price: (i) as the amount of purchased allowances increases, for the same allowance price, the selling price of a product increases; (ii) as the allowance price increases, for the same amount of purchased allowances, the selling price of a product increases as well.

Table 5.1. Impact of the legislative package on industrial activities covered by ETS

Sector		Percentage (not allocated), %							
		5	10	15	20	25	30	35	40
<i>Energy (Power Plants)</i>									
<b>Profit reduction, %</b>									
15 €/certificate	0	70.04	53.12	35.98	13.49	-7.50	-30.19	-54.78	-95.52
20 €/certificate		61.95	38.86	14.30	-13.32	-44.63	-80.42	-121.71	-163.88
25 €/certificate		50.09	21.53	-6.22	-35.25	-68.65	-97.50	-150.94	-220.00
15 €/certificate	1	69.54	52.46	33.38	11.92	-12.41	-40.22	-72.30	-109.73
20 €/certificate		59.44	36.68	11.25	-17.37	-49.79	-86.86	-129.62	-166.06
25 €/certificate		49.34	20.90	-10.89	-46.65	-87.18	-133.49	-186.93	-249.28
15 €/certificate	2	72.31	56.79	39.44	19.92	-2.19	-27.47	-56.64	-90.66
20 €/certificate		63.12	42.44	19.32	-6.70	-36.18	-69.87	-108.74	-154.10
25 €/certificate		53.94	28.09	-0.81	-33.32	-70.16	-112.27	-160.85	-217.53
30 €/certificate	3	41.33	8.38	-28.44	-69.87	-116.82	-170.48	-232.39	-304.62
35 €/certificate		31.58	-6.86	-49.82	-98.14	-152.91	-215.51	-287.73	-371.99
40 €/certificate		21.82	-22.10	-71.19	-126.42	-189.01	-260.54	-343.07	-439.37
30 €/certificate	4	39.24	5.11	-33.03	-75.93	-124.56	-180.13	-244.25	-319.06
35 €/certificate		29.14	-10.67	-55.16	-105.21	-161.94	-226.77	-301.57	-388.84
40 €/certificate		19.03	-26.46	-77.30	-134.50	-199.32	-273.40	-358.88	-458.61
30 €/certificate	5	44.76	13.74	-20.93	-59.94	-104.14	-154.66	-212.96	-280.96
35 €/certificate		35.58	-0.61	-41.06	-86.56	-138.13	-197.06	-265.06	-344.40
40 €/certificate		26.40	-14.96	-61.18	-113.18	-172.11	-239.46	-317.17	-407.83
<b>Increase of the selling price, %</b>									
15 €/certificate	0	103.74	105.83	108.17	110.81	113.80	117.21	121.15	125.74
20 €/certificate		104.98	107.77	110.89	114.40	118.38	122.93	128.18	134.30
25 €/certificate		106.22	109.71	113.61	118.00	122.97	128.66	135.22	142.87
15 €/certificate	1	103.87	106.04	108.46	111.19	114.28	117.81	121.88	126.64
20 €/certificate		105.15	108.04	111.27	114.91	119.03	123.73	129.17	135.50
25 €/certificate		106.43	110.05	114.08	118.63	123.77	129.66	136.45	144.37
15 €/certificate	2	103.51	105.49	107.69	110.17	112.98	116.19	119.89	124.22
20 €/certificate		104.68	107.31	110.25	113.55	117.30	121.58	126.51	132.27
25 €/certificate		105.85	109.13	112.80	116.93	121.61	126.96	133.13	140.33

Table 5.1 (continued)

30 €/certificate		107.46	111.64	116.33	121.59	127.56	134.38	142.25	151.43
35 €/certificate	3	108.70	113.58	119.04	125.19	132.15	140.10	149.28	160.00
40 €/certificate		109.94	115.52	121.76	128.78	136.74	145.83	156.32	168.56
30 €/certificate		107.72	112.05	116.90	122.35	128.52	135.58	143.73	153.23
35 €/certificate	4	109.00	114.06	119.71	126.07	133.27	141.51	151.01	162.09
40 €/certificate		110.28	116.06	122.52	129.78	138.02	147.43	158.29	170.96
30 €/certificate		107.01	110.95	115.36	120.31	125.93	132.35	139.75	148.39
35 €/certificate	5	108.18	112.78	117.92	123.70	130.25	137.73	146.37	156.45
40 €/certificate		109.35	114.60	120.47	127.08	134.56	143.12	152.99	164.51
<i>Energy (Power Plants) – electrical energy</i>									
<b>Profit reduction, %</b>									
15 €/certificate		48.60	19.79	-12.42	-48.64	-89.70	-136.63	-190.77	-253.94
20 €/certificate	0	31.55	-6.85	-49.77	-98.06	-152.79	-215.33	-287.50	-371.69
25 €/certificate		14.51	-33.49	-87.13	-147.48	-215.87	-294.04	-384.23	-489.45
15 €/certificate		34.64	-2.00	-42.95	-89.02	-141.23	-200.90	-269.75	-350.08
20 €/certificate	1	12.96	-35.87	-90.46	-151.86	-221.45	-300.99	-392.75	-499.82
25 €/certificate		-8.71	-69.75	-137.96	-214.70	-301.67	-401.07	-515.76	-649.56
15 €/certificate		51.64	24.53	-5.77	-39.86	-78.49	-122.64	-173.59	-233.02
20 €/certificate	2	35.60	-0.54	-40.92	-86.36	-137.85	-196.70	-264.60	-343.82
25 €/certificate		19.56	-25.60	-76.07	-132.85	-197.21	-270.75	-355.61	-454.62
30 €/certificate		-2.54	-60.13	-124.49	-196.90	-278.96	-372.75	-480.96	-607.21
35 €/certificate	3	-19.59	-86.77	-161.85	-246.32	-342.05	-451.45	-577.69	-724.96
40 €/certificate		-36.63	-113.40	-199.20	-295.73	-405.13	-530.16	-674.42	-842.72
30 €/certificate		-6.13	-65.73	-132.35	-207.29	-292.22	-389.29	-501.29	-631.96
35 €/certificate	4	-23.77	-93.30	-171.01	-258.43	-357.52	-470.75	-601.41	-753.84
40 €/certificate		-41.41	-120.87	-209.68	-309.58	-422.81	-552.21	-701.52	-875.72
30 €/certificate		3.52	-50.66	-111.22	-179.35	-256.56	-344.81	-446.63	-565.42
35 €/certificate	5	-12.52	-75.73	-146.37	-225.85	-315.92	-418.86	-537.64	-676.21
40 €/certificate		-28.56	-100.79	-181.52	-272.35	-375.28	-492.92	-628.65	-787.01
<b>Increase of the selling price, %</b>									
15 €/certificate		103.52	104.99	106.62	108.46	110.54	112.92	115.67	118.88
20 €/certificate	0	104.39	106.34	108.52	110.97	113.74	116.92	120.58	124.85
25 €/certificate		105.25	107.69	110.41	113.47	116.95	120.91	125.49	130.83

Table 5.1 (continued)

15 €/certificate		103.61	105.13	106.82	108.72	110.88	113.34	116.19	119.51
20 €/certificate	1	104.51	106.53	108.78	111.32	114.19	117.48	121.27	125.69
25 €/certificate		105.40	107.93	110.74	113.91	117.51	121.61	126.35	131.88
15 €/certificate		103.37	104.74	106.28	108.01	109.97	112.21	114.80	117.82
20 €/certificate	2	104.18	106.02	108.07	110.37	112.99	115.97	119.42	123.44
25 €/certificate		105.00	107.29	109.85	112.73	116.00	119.73	124.04	129.06
30 €/certificate		106.12	109.04	112.31	115.98	120.15	124.91	130.40	136.81
35 €/certificate	3	106.98	110.39	114.20	118.49	123.35	128.90	135.31	142.78
40 €/certificate		107.85	111.74	116.10	121.00	126.55	132.90	140.22	148.76
30 €/certificate		106.30	109.71	113.10	116.92	121.25	126.19	131.89	138.55
35 €/certificate	4	107.20	110.72	114.67	119.11	124.13	129.88	136.51	144.25
40 €/certificate		108.09	112.12	116.63	121.70	127.45	134.01	141.59	150.43
30 €/certificate		105.81	108.56	111.63	115.09	119.01	123.49	128.66	134.69
35 €/certificate	5	106.62	109.83	113.42	117.45	122.02	127.25	133.28	140.31
40 €/certificate		107.44	111.10	115.20	119.81	125.04	131.01	137.89	145.93
<i>Energy (Power Plants) – thermal energy</i>									
<b>Profit reduction, %</b>									
15 €/certificate		48.60	19.79	-12.42	-48.64	-89.70	-136.63	-190.77	-253.94
20 €/certificate	0	31.55	-6.85	-49.77	-98.06	-152.79	-215.33	-287.50	-371.69
25 €/certificate		14.51	-33.49	-87.13	-147.48	-215.87	-294.04	-384.23	-489.45
15 €/certificate		34.64	-2.00	-42.95	-89.02	-141.23	-200.90	-269.75	-350.08
20 €/certificate	1	12.96	-35.87	-90.46	-151.86	-221.45	-300.99	-392.75	-499.82
25 €/certificate		-8.71	-69.75	-137.96	-214.70	-301.67	-401.07	-515.76	-649.56
15 €/certificate		51.64	24.53	-5.77	-39.86	-78.49	-122.64	-173.59	-233.02
20 €/certificate	2	35.60	-0.54	-40.92	-86.36	-137.85	-196.70	-264.60	-343.82
25 €/certificate		19.56	-25.60	-76.07	-132.85	-197.21	-270.75	-355.61	-454.62
30 €/certificate		-2.54	-60.13	-124.49	-196.90	-278.96	-372.75	-480.96	-607.21
35 €/certificate	3	-19.59	-86.77	-161.85	-246.32	-342.05	-451.45	-577.69	-724.96
40 €/certificate		-36.63	-113.40	-199.20	-295.73	-405.13	-530.16	-674.42	-842.72
30 €/certificate		-6.13	-65.73	-132.35	-207.29	-292.22	-389.29	-501.29	-631.96
35 €/certificate	4	-23.77	-93.30	-171.01	-258.43	-357.52	-470.75	-601.41	-753.84
40 €/certificate		-41.41	-120.87	-209.68	-309.58	-422.81	-552.21	-701.52	-875.72



Table 5.1 (continued)

30 €/certificate		3.52	-50.66	-111.22	-179.35	-256.56	-344.81	-446.63	-565.42
35 €/certificate	5	-12.52	-75.73	-146.37	-225.85	-315.92	-418.86	-537.64	-676.21
40 €/certificate		-28.56	-100.79	-181.52	-272.35	-375.28	-492.92	-628.65	-787.01
<b>Increase of the selling price, %</b>									
15 €/certificate		100.51	101.93	103.51	105.29	107.31	109.62	112.28	115.39
20 €/certificate	0	101.35	103.24	105.35	107.72	110.42	113.49	117.04	121.18
25 €/certificate		102.31	104.68	107.32	110.29	113.66	117.51	121.95	127.13
15 €/certificate		100.94	102.41	104.06	105.92	108.02	110.42	113.19	116.42
20 €/certificate	1	101.81	103.78	105.97	108.45	111.25	114.45	118.14	122.45
25 €/certificate		102.81	105.27	108.02	111.11	114.62	118.62	123.24	128.63
15 €/certificate		100.70	102.04	103.54	105.23	107.14	109.32	111.84	114.78
20 €/certificate	2	101.49	103.28	105.28	107.52	110.07	112.98	116.34	120.25
25 €/certificate		102.41	104.65	107.15	109.96	113.14	116.79	120.99	125.89
30 €/certificate		103.38	106.23	109.41	112.99	117.05	121.68	127.03	133.28
35 €/certificate	3	104.22	107.54	111.26	115.43	120.17	125.57	131.82	139.10
40 €/certificate		105.20	109.00	113.24	118.02	123.44	129.63	136.77	145.10
30 €/certificate		103.92	106.88	110.18	113.90	118.12	122.93	128.49	134.97
35 €/certificate	4	104.43	107.87	111.71	116.03	120.93	126.53	132.99	140.53
40 €/certificate		105.43	109.37	113.76	118.71	124.31	130.72	138.11	146.73
30 €/certificate		103.08	105.76	108.75	112.12	115.94	120.30	125.34	131.21
35 €/certificate	5	103.87	107.00	110.49	114.42	118.87	123.96	129.84	136.69
40 €/certificate		104.80	108.37	112.37	116.86	121.96	127.78	134.50	142.34
<i>Refinery</i>									
<b>Profit reduction, %</b>									
15 €/certificate		98.72	98.41	98.08	97.70	97.27	96.77	96.21	95.55
20 €/certificate	0	98.54	98.13	97.68	97.18	96.60	95.95	95.19	94.31
25 €/certificate		98.36	97.85	97.29	96.66	95.94	95.12	94.18	93.08
15 €/certificate		98.58	98.20	97.78	97.31	96.77	96.16	95.45	94.62
20 €/certificate	1	98.36	97.86	97.29	96.66	95.95	95.13	94.18	93.08
25 €/certificate		98.13	97.51	96.81	96.02	95.12	94.10	92.92	91.54
15 €/certificate		98.66	98.31	97.93	97.51	97.02	96.47	95.83	95.08
20 €/certificate	2	98.45	98.00	97.49	96.92	96.28	95.54	94.69	93.69
25 €/certificate		98.25	97.69	97.05	96.34	95.53	94.61	93.54	92.30

Table 5.1 (continued)

30 €/certificate		98.18	97.58	96.90	96.14	95.28	94.30	93.16	91.84
35 €/certificate	3	98.00	97.30	96.51	95.62	94.62	93.47	92.15	90.61
40 €/certificate		97.82	97.02	96.12	95.11	93.96	92.65	91.14	89.37
30 €/certificate		97.91	97.16	96.32	95.37	94.29	93.07	91.65	90.00
35 €/certificate	4	97.69	96.81	95.83	94.72	93.47	92.04	90.39	88.46
40 €/certificate		97.47	96.46	95.34	94.07	92.64	91.01	89.12	86.92
30 €/certificate		98.05	97.37	96.61	95.76	94.79	93.68	92.40	90.91
35 €/certificate	5	97.85	97.06	96.17	95.17	94.04	92.75	91.26	89.52
40 €/certificate		97.65	96.74	95.73	94.59	93.30	91.82	90.12	88.13
<b>Increase of the selling price, %</b>									
15 €/certificate		100.13	100.16	100.19	100.23	100.27	100.32	100.38	100.45
20 €/certificate	0	100.15	100.19	100.23	100.28	100.34	100.41	100.48	100.57
25 €/certificate		100.16	100.21	100.27	100.33	100.41	100.49	100.58	100.69
15 €/certificate		100.14	100.18	100.22	100.27	100.32	100.38	100.45	100.54
20 €/certificate	1	100.16	100.21	100.27	100.33	100.41	100.49	100.58	100.69
25 €/certificate		100.19	100.25	100.32	100.40	100.49	100.59	100.71	100.85
15 €/certificate		100.13	100.17	100.21	100.25	100.30	100.35	100.42	100.49
20 €/certificate	2	100.15	100.20	100.25	100.31	100.37	100.45	100.53	100.63
25 €/certificate		100.17	100.23	100.29	100.37	100.45	100.54	100.65	100.77
30 €/certificate		100.18	100.24	100.31	100.39	100.47	100.57	100.68	100.82
35 €/certificate	3	100.20	100.27	100.35	100.44	100.54	100.65	100.78	100.94
40 €/certificate		100.22	100.30	100.39	100.49	100.60	100.74	100.89	101.06
30 €/certificate		100.21	100.28	100.37	100.46	100.57	100.69	100.83	101.00
35 €/certificate	4	100.23	100.32	100.42	100.53	100.65	100.80	100.96	101.15
40 €/certificate		100.25	100.35	100.47	100.59	100.74	100.90	101.09	101.31
30 €/certificate		100.19	100.26	100.34	100.42	100.52	100.63	100.76	100.91
35 €/certificate	5	100.22	100.29	100.38	100.48	100.60	100.73	100.87	101.05
40 €/certificate		100.24	100.33	100.43	100.54	100.67	100.82	100.99	101.19
<i>Ferrous metals</i>									
<b>Profit reduction, %</b>									
15 €/certificate		70.84	68.56	66.01	63.14	59.89	56.18	51.90	46.90
20 €/certificate	0	69.49	66.45	63.05	59.23	54.90	49.95	44.24	37.57
25 €/certificate		68.14	64.34	60.09	55.32	49.90	43.71	36.58	28.25

Table 5.1 (continued)

15 €/certificate		70.43	67.85	64.96	61.72	58.05	53.85	49.00	43.35
20 €/certificate	1	68.90	65.46	61.62	57.30	52.40	46.80	40.34	32.80
25 €/certificate		67.37	63.07	58.27	52.87	46.75	39.75	31.67	22.25
15 €/certificate		69.59	66.70	63.47	59.83	55.71	51.00	45.57	39.23
20 €/certificate	2	67.88	64.03	59.72	54.87	49.38	43.10	35.85	27.40
25 €/certificate		66.17	61.35	55.96	49.91	43.04	35.19	26.14	15.57
30 €/certificate		66.57	61.89	56.66	50.78	44.11	36.49	27.70	17.45
35 €/certificate	3	65.18	59.72	53.62	46.76	38.98	30.10	19.84	7.88
40 €/certificate		63.80	57.56	50.59	42.75	33.86	23.70	11.98	-1.69
30 €/certificate		65.85	60.69	54.93	48.44	41.09	32.70	23.01	11.70
35 €/certificate	4	64.32	58.30	51.58	44.02	35.44	25.65	14.34	1.16
40 €/certificate		62.79	55.92	48.23	39.59	29.79	18.60	5.68	-9.39
30 €/certificate		64.44	58.66	52.19	44.92	36.68	27.26	16.39	3.71
35 €/certificate	5	62.73	55.98	48.44	39.96	30.34	19.35	6.67	-8.12
40 €/certificate		61.02	53.30	44.69	34.99	24.00	11.44	-3.05	-19.96
<b>Increase of the selling price, %</b>									
15 €/certificate		100.76	100.82	100.89	100.97	101.05	101.15	101.26	101.39
20 €/certificate	0	100.80	100.88	100.97	101.07	101.18	101.31	101.46	101.64
25 €/certificate		100.83	100.93	101.05	101.17	101.31	101.47	101.66	101.88
15 €/certificate		100.77	100.84	100.92	101.00	101.10	101.21	101.34	101.48
20 €/certificate	1	100.81	100.90	101.01	101.12	101.25	101.39	101.56	101.76
25 €/certificate		100.85	100.97	101.09	101.23	101.40	101.58	101.79	102.04
15 €/certificate		100.80	100.87	100.96	101.05	101.16	101.28	101.43	101.59
20 €/certificate	2	100.84	100.94	101.06	101.18	101.33	101.49	101.68	101.90
25 €/certificate		100.89	101.01	101.15	101.31	101.49	101.70	101.94	102.21
30 €/certificate		100.88	101.00	101.14	101.29	101.46	101.66	101.89	102.16
35 €/certificate	3	100.91	101.06	101.22	101.39	101.60	101.83	102.10	102.41
40 €/certificate		100.95	101.11	101.29	101.50	101.73	102.00	102.31	102.66
30 €/certificate		100.89	101.03	101.18	101.35	101.54	101.76	102.02	102.31
35 €/certificate	4	100.93	101.09	101.27	101.47	101.69	101.95	102.24	102.59
40 €/certificate		100.97	101.15	101.36	101.58	101.84	102.13	102.47	102.87
30 €/certificate		100.93	101.08	101.25	101.44	101.66	101.91	102.19	102.52
35 €/certificate	5	100.98	101.15	101.35	101.57	101.83	102.11	102.45	102.83
40 €/certificate		101.02	101.22	101.45	101.70	101.99	102.32	102.70	103.14

Table 5.1 (continued)

<i>Cement</i>									
<b>Profit reduction, %</b>									
15 €/certificate	0	83.18	77.39	70.93	63.66	55.42	46.00	35.13	22.45
20 €/certificate		79.75	72.04	63.43	53.73	42.75	30.19	15.71	-1.20
25 €/certificate		76.33	66.69	55.92	43.81	30.08	14.39	-3.72	-24.85
15 €/certificate	1	77.21	68.50	58.78	47.84	35.44	21.27	4.92	-14.16
20 €/certificate		82.23	70.63	57.66	43.08	26.55	7.66	-14.14	-39.57
25 €/certificate		79.62	65.12	48.92	30.69	10.03	-13.58	-40.83	-72.62
15 €/certificate	2	78.82	70.91	62.07	52.13	40.85	27.97	13.11	-4.24
20 €/certificate		74.14	63.60	51.81	38.55	23.52	6.35	-13.47	-36.59
25 €/certificate		69.46	56.28	41.55	24.97	6.19	-15.27	-40.04	-68.94
30 €/certificate	3	72.91	61.34	48.42	33.88	17.41	-1.42	-23.15	-48.50
35 €/certificate		69.48	55.99	40.92	23.96	4.74	-17.23	-42.58	-72.15
40 €/certificate		66.06	50.64	33.42	14.03	-7.93	-33.04	-62.00	-95.80
30 €/certificate	4	61.75	44.35	24.91	3.04	-21.76	-50.09	-82.78	-120.92
35 €/certificate		56.60	36.30	13.62	-11.90	-40.82	-73.87	-112.01	-156.51
40 €/certificate		51.45	28.25	2.33	-26.83	-59.88	-97.66	-141.24	-192.09
30 €/certificate	5	64.77	48.95	31.28	11.39	-11.15	-36.91	-66.62	-101.30
35 €/certificate		60.08	41.63	21.01	-2.19	-28.48	-58.53	-93.20	-133.65
40 €/certificate		55.40	34.32	10.75	-15.76	-45.81	-80.15	-119.77	-166.00
<b>Increase of the selling price, %</b>									
15 €/certificate	0	102.51	103.37	104.35	105.44	106.68	108.09	109.72	111.63
20 €/certificate		103.02	104.18	105.47	106.93	108.58	110.46	112.64	115.18
25 €/certificate		103.53	104.98	106.60	108.42	110.48	112.84	115.56	118.73
15 €/certificate	1	103.40	104.71	106.17	107.81	109.68	111.81	114.26	117.13
20 €/certificate		102.65	104.39	106.34	108.53	111.01	113.85	117.12	120.94
25 €/certificate		103.04	105.22	107.65	110.39	113.49	117.04	121.13	125.91
15 €/certificate	2	103.16	104.35	105.68	107.17	108.86	110.80	113.03	115.64
20 €/certificate		103.86	105.45	107.22	109.21	111.47	114.05	117.02	120.50
25 €/certificate		104.57	106.55	108.76	111.25	114.07	117.29	121.02	125.36
30 €/certificate	3	104.05	105.79	107.73	109.91	112.39	115.21	118.48	122.29
35 €/certificate		104.56	106.59	108.85	111.40	114.29	117.59	121.40	125.84
40 €/certificate		105.08	107.39	109.98	112.89	116.19	119.96	124.31	129.39

Table 5.1 (continued)

30 €/certificate		105.72	108.34	111.26	114.54	118.27	122.52	127.43	133.16
35 €/certificate	4	106.50	109.55	112.95	116.79	121.13	126.10	131.83	138.51
40 €/certificate		107.27	110.76	114.65	119.03	124.00	129.67	136.22	143.86
30 €/certificate		105.27	107.65	110.30	113.29	116.67	120.54	125.01	130.22
35 €/certificate	5	105.97	108.75	111.84	115.33	119.28	123.79	129.00	135.08
40 €/certificate		106.68	109.85	113.39	117.37	121.88	127.04	132.99	139.94
<i>Lime</i>									
<b>Profit reduction, %</b>									
15 €/certificate		82.80	74.22	64.64	53.86	41.64	27.68	11.57	-7.23
20 €/certificate	0	77.72	66.29	53.52	39.15	22.86	4.25	-17.23	-42.29
25 €/certificate		72.65	58.36	42.39	24.43	4.08	-19.19	-46.04	-77.35
15 €/certificate		79.21	68.72	57.00	43.82	28.88	11.81	-7.90	-30.88
20 €/certificate	1	73.00	59.02	43.40	25.83	5.91	-16.85	-43.12	-73.76
25 €/certificate		66.79	49.32	29.80	7.83	-17.06	-45.51	-78.34	-116.64
15 €/certificate		81.05	71.55	60.94	48.99	35.46	19.99	2.14	-18.69
20 €/certificate	2	75.43	62.77	48.61	32.69	14.64	-5.98	-29.78	-57.54
25 €/certificate		69.81	53.98	36.29	16.39	-6.17	-31.94	-61.69	-96.39
30 €/certificate		67.56	50.42	31.26	9.71	-14.72	-42.64	-74.85	-112.43
35 €/certificate	3	62.49	42.49	20.14	-5.01	-33.50	-66.07	-103.65	-147.49
40 €/certificate		57.41	34.56	9.01	-19.72	-52.29	-89.51	-132.45	-182.56
30 €/certificate		60.58	39.62	16.19	-10.16	-40.03	-74.17	-113.56	-159.52
35 €/certificate	4	54.38	29.92	2.59	-28.16	-63.00	-102.83	-148.78	-202.39
40 €/certificate		48.17	20.22	-11.01	-46.15	-85.97	-131.49	-184.00	-245.27
30 €/certificate		64.06	45.01	23.71	-0.25	-27.41	-58.44	-94.25	-136.03
35 €/certificate	5	58.42	36.19	11.34	-16.61	-48.29	-84.50	-126.27	-175.01
40 €/certificate		52.78	27.37	-1.02	-32.97	-69.17	-110.55	-158.29	-213.99
<b>Increase of the selling price, %</b>									
15 €/certificate		101.72	102.58	103.54	104.61	105.84	107.23	108.84	110.72
20 €/certificate	0	102.23	103.37	104.65	106.09	107.71	109.58	111.72	114.23
25 €/certificate		102.74	104.16	105.76	107.56	109.59	111.92	114.60	117.74
15 €/certificate		102.08	103.13	104.30	105.62	107.11	108.82	110.79	113.09
20 €/certificate	1	102.70	104.10	105.66	107.42	109.41	111.69	114.31	117.38
25 €/certificate		103.32	105.07	107.02	109.22	111.71	114.55	117.83	121.66

Table 5.1 (continued)

15 €/certificate		101.87	102.82	103.89	105.08	106.44	107.99	109.79	111.88
20 €/certificate	2	102.43	103.70	105.12	106.72	108.53	110.60	112.99	115.77
25 €/certificate		103.00	104.58	106.36	108.36	110.62	113.21	116.19	119.67
30 €/certificate		103.24	104.96	106.87	109.03	111.47	114.26	117.48	121.24
35 €/certificate	3	103.75	105.75	107.99	110.50	113.35	116.61	120.37	124.75
40 €/certificate		104.26	106.54	109.10	111.97	115.23	118.95	123.25	128.26
30 €/certificate		103.94	106.04	108.38	111.02	114.00	117.42	121.36	125.95
35 €/certificate	4	104.56	107.01	109.74	112.82	116.30	120.28	124.88	130.24
40 €/certificate		105.18	107.98	111.10	114.62	118.60	123.15	128.40	134.53
30 €/certificate		103.59	105.50	107.63	110.03	112.74	115.84	119.43	123.60
35 €/certificate	5	104.16	106.38	108.87	111.66	114.83	118.45	122.63	127.50
40 €/certificate		104.72	107.26	110.10	113.30	116.92	121.05	125.83	131.40
<i>Pulp and paper</i>									
<b>Profit reduction, %</b>									
15 €/certificate		73.08	68.65	63.69	58.12	51.81	44.59	36.26	26.55
20 €/certificate	0	70.45	64.55	57.94	50.52	42.10	32.48	21.38	8.42
25 €/certificate		67.83	60.45	52.19	42.91	32.39	20.36	6.49	-9.70
15 €/certificate		71.04	65.33	58.94	51.76	43.62	34.31	23.57	11.05
20 €/certificate	1	67.67	60.06	51.55	41.98	31.14	18.74	4.44	-12.24
25 €/certificate		64.30	54.79	44.16	32.21	18.66	3.18	-14.69	-35.53
15 €/certificate		69.47	63.06	55.89	47.82	38.68	28.23	16.18	2.11
20 €/certificate	2	65.69	57.14	47.59	36.85	24.67	10.75	-5.30	-24.04
25 €/certificate		61.90	51.23	39.30	25.87	10.66	-6.72	-26.78	-50.19
30 €/certificate		65.21	56.35	46.45	35.31	22.68	8.25	-8.40	-27.82
35 €/certificate	3	62.58	52.25	40.70	27.70	12.97	-3.86	-23.29	-45.95
40 €/certificate		59.96	48.15	34.95	20.09	3.26	-15.98	-38.17	-64.07
30 €/certificate		60.93	49.52	36.78	22.44	6.18	-12.39	-33.82	-58.82
35 €/certificate	4	57.56	44.25	29.39	12.66	-6.29	-27.95	-52.95	-82.11
40 €/certificate		54.18	38.99	22.00	2.89	-18.77	-43.52	-72.08	-105.40
30 €/certificate		58.12	45.31	31.00	14.90	-3.35	-24.20	-48.26	-76.34
35 €/certificate	5	54.33	39.40	22.71	3.93	-17.36	-41.68	-69.74	-102.49
40 €/certificate		50.55	33.48	14.41	-7.05	-31.36	-59.16	-91.22	-128.64

Table 5.1 (continued)

Increase of the selling price, %									
15 €/certificate	0	100.81	100.94	101.09	101.26	101.45	101.66	101.91	102.20
20 €/certificate		100.89	101.06	101.26	101.48	101.74	102.03	102.36	102.75
25 €/certificate		100.97	101.19	101.43	101.71	102.03	102.39	102.81	103.29
15 €/certificate	1	100.87	101.04	101.23	101.45	101.69	101.97	102.29	102.67
20 €/certificate		100.97	101.20	101.45	101.74	102.07	102.44	102.87	103.37
25 €/certificate		101.07	101.36	101.68	102.03	102.44	102.90	103.44	104.07
15 €/certificate	2	100.92	101.11	101.32	101.57	101.84	102.15	102.51	102.94
20 €/certificate		101.03	101.29	101.57	101.89	102.26	102.68	103.16	103.72
25 €/certificate		101.14	101.46	101.82	102.22	102.68	103.20	103.80	104.51
30 €/certificate	3	101.04	101.31	101.61	101.94	102.32	102.75	103.25	103.83
35 €/certificate		101.12	101.43	101.78	102.17	102.61	103.12	103.70	104.38
40 €/certificate		101.20	101.56	101.95	102.40	102.90	103.48	104.14	104.92
30 €/certificate	4	101.17	101.51	101.90	102.33	102.81	103.37	104.01	104.76
35 €/certificate		101.27	101.67	102.12	102.62	103.19	103.84	104.59	105.46
40 €/certificate		101.37	101.83	102.34	102.91	103.56	104.31	105.16	106.16
30 €/certificate	5	101.26	101.64	102.07	102.55	103.10	103.73	104.45	105.29
35 €/certificate		101.37	101.82	102.32	102.88	103.52	104.25	105.09	106.07
40 €/certificate		101.48	102.00	102.57	103.21	103.94	104.77	105.74	106.86
<i>Glass</i>									
Profit reduction, %									
15 €/certificate	0	50.52	39.29	26.73	12.61	-3.40	-21.69	-42.80	-67.42
20 €/certificate		43.87	28.89	12.16	-6.67	-28.01	-52.39	-80.53	-113.36
25 €/certificate		37.22	18.50	-2.42	-25.95	-52.62	-83.10	-118.27	-159.30
15 €/certificate	1	47.84	35.15	20.96	5.01	-13.07	-33.74	-57.58	-85.40
20 €/certificate		40.32	23.41	4.50	-16.77	-40.88	-68.43	-100.21	-137.30
25 €/certificate		32.81	11.67	-11.96	-38.55	-68.68	-103.11	-142.84	-189.20
15 €/certificate	2	45.35	31.29	15.58	-2.10	-22.13	-45.03	-71.44	-102.26
20 €/certificate		37.02	18.28	-2.66	-26.23	-52.93	-83.45	-118.67	-159.75
25 €/certificate		28.70	5.28	-20.90	-50.35	-83.73	-121.88	-165.89	-217.25
30 €/certificate	3	30.57	8.11	-16.99	-45.23	-77.23	-113.80	-156.00	-205.24
35 €/certificate		23.92	-2.28	-31.56	-64.50	-101.84	-144.50	-193.74	-251.17
40 €/certificate		17.27	-12.67	-46.13	-83.78	-126.45	-175.21	-231.47	-297.11

Table 5.1 (continued)

30 €/certificate		25.30	-0.07	-28.43	-60.33	-96.48	-137.80	-185.47	-241.09
35 €/certificate	4	17.79	-11.81	-44.89	-82.10	-124.28	-172.48	-228.10	-292.99
40 €/certificate		10.27	-23.55	-61.35	-103.88	-152.08	-207.17	-270.73	-344.88
30 €/certificate		20.38	-7.73	-39.14	-74.48	-114.53	-160.30	-213.12	-274.74
35 €/certificate	5	12.06	-20.73	-57.38	-98.61	-145.33	-198.73	-260.35	-332.23
40 €/certificate		3.74	-33.74	-75.62	-122.73	-176.13	-237.16	-307.57	-389.72
<b>Increase of the selling price, %</b>									
15 €/certificate		102.48	103.04	103.66	104.37	105.17	106.08	107.14	108.37
20 €/certificate	0	102.81	103.56	104.39	105.33	106.40	107.62	109.02	110.66
25 €/certificate		103.14	104.08	105.12	106.30	107.63	109.15	110.91	112.96
15 €/certificate		102.61	103.24	103.95	104.75	105.65	106.69	107.88	109.27
20 €/certificate	1	102.99	103.83	104.78	105.84	107.04	108.42	110.01	111.86
25 €/certificate		103.36	104.42	105.60	106.93	108.43	110.15	112.14	114.45
15 €/certificate		102.73	103.44	104.22	105.10	106.11	107.25	108.57	110.11
20 €/certificate	2	103.15	104.09	105.13	106.31	107.64	109.17	110.93	112.98
25 €/certificate		103.57	104.74	106.04	107.52	109.18	111.09	113.29	115.85
30 €/certificate		103.47	104.59	105.85	107.26	108.86	110.69	112.79	115.25
35 €/certificate	3	103.80	105.11	106.58	108.22	110.09	112.22	114.68	117.55
40 €/certificate		104.14	105.63	107.30	109.19	111.32	113.75	116.56	119.84
30 €/certificate		103.74	105.00	106.42	108.01	109.82	111.88	114.27	117.05
35 €/certificate	4	104.11	105.59	107.24	109.10	111.21	113.62	116.40	119.64
40 €/certificate		104.49	106.18	108.07	110.19	112.60	115.35	118.53	122.23
30 €/certificate		103.98	105.39	106.96	108.72	110.72	113.01	115.65	118.73
35 €/certificate	5	104.40	106.04	107.87	109.93	112.26	114.93	118.01	121.60
40 €/certificate		104.81	106.69	108.78	111.13	113.80	116.85	120.37	124.47
<i>Ceramic</i>									
<b>Profit reduction, %</b>									
15 €/certificate		93.21	91.39	89.36	87.07	84.48	81.52	78.11	74.12
20 €/certificate	0	92.13	89.71	87.00	83.96	80.50	76.56	72.00	66.69
25 €/certificate		91.06	88.03	84.64	80.84	76.52	71.59	65.90	59.26
15 €/certificate		92.50	90.34	87.93	85.21	82.14	78.62	74.56	69.83
20 €/certificate	1	91.22	88.34	85.13	81.51	77.40	72.72	67.31	61.00
25 €/certificate		89.94	86.35	82.32	77.80	72.67	66.82	60.05	52.17



Table 5.1 (continued)

15 €/certificate		91.95	89.54	86.84	83.81	80.37	76.44	71.91	66.62
20 €/certificate	2	90.53	87.31	83.71	79.67	75.08	69.85	63.80	56.75
25 €/certificate		89.10	85.08	80.58	75.53	69.80	63.25	55.69	46.88
30 €/certificate		89.98	86.35	82.29	77.72	72.54	66.62	59.79	51.82
35 €/certificate	3	88.91	84.67	79.93	74.60	68.56	61.65	53.68	44.39
40 €/certificate		87.83	82.98	77.57	71.48	64.57	56.68	47.58	36.96
30 €/certificate		88.66	84.35	79.52	74.10	67.94	60.91	52.80	43.34
35 €/certificate	4	87.39	82.35	76.72	70.39	63.21	55.01	45.55	34.51
40 €/certificate		86.11	80.35	73.92	66.68	58.48	49.11	38.29	25.68
30 €/certificate		87.67	82.84	77.45	71.39	64.51	56.65	47.59	37.01
35 €/certificate	5	86.24	80.61	74.32	67.24	59.22	50.06	39.48	27.14
40 €/certificate		84.81	78.38	71.19	63.10	53.94	43.46	31.37	17.27
<b>Increase of the selling price, %</b>									
15 €/certificate		100.34	100.43	100.53	100.65	100.78	100.92	101.09	101.29
20 €/certificate	0	100.39	100.51	100.65	100.80	100.97	101.17	101.40	101.67
25 €/certificate		100.45	100.60	100.77	100.96	101.17	101.42	101.71	102.04
15 €/certificate		100.38	100.48	100.60	100.74	100.89	101.07	101.27	101.51
20 €/certificate	1	100.44	100.58	100.74	100.92	101.13	101.36	101.63	101.95
25 €/certificate		100.50	100.68	100.88	101.11	101.37	101.66	102.00	102.39
15 €/certificate		100.40	100.52	100.66	100.81	100.98	101.18	101.40	101.67
20 €/certificate	2	100.47	100.63	100.81	101.02	101.25	101.51	101.81	102.16
25 €/certificate		100.55	100.75	100.97	101.22	101.51	101.84	102.22	102.66
30 €/certificate		100.50	100.68	100.89	101.11	101.37	101.67	102.01	102.41
35 €/certificate	3	100.55	100.77	101.00	101.27	101.57	101.92	102.32	102.78
40 €/certificate		100.61	100.85	101.12	101.43	101.77	102.17	102.62	103.15
30 €/certificate		100.57	100.78	101.02	101.30	101.60	101.95	102.36	102.83
35 €/certificate	4	100.63	100.88	101.16	101.48	101.84	102.25	102.72	103.27
40 €/certificate		100.69	100.98	101.30	101.67	102.08	102.54	103.09	103.72
30 €/certificate		100.62	100.86	101.13	101.43	101.77	102.17	102.62	103.15
35 €/certificate	5	100.69	100.97	101.28	101.64	102.04	102.50	103.03	103.64
40 €/certificate		100.76	101.08	101.44	101.84	102.30	102.83	103.43	104.14

Table 5.1 (continued)

<i>Energy and lime</i>									
<b>Profit reduction, %</b>									
15 €/certificate	0	98.79	98.42	98.01	97.55	97.02	96.43	95.74	94.93
20 €/certificate		98.57	98.08	97.53	96.92	96.22	95.42	94.51	93.43
25 €/certificate		98.35	97.74	97.06	96.29	95.42	94.42	93.27	91.93
15 €/certificate	1	98.52	98.00	97.43	96.79	96.06	95.23	94.27	93.15
20 €/certificate		98.21	97.53	96.77	95.91	94.94	93.83	92.55	91.05
25 €/certificate		97.91	97.06	96.11	95.03	93.82	92.43	90.83	88.96
15 €/certificate	2	98.41	97.84	97.21	96.49	95.68	94.76	93.69	92.45
20 €/certificate		98.07	97.32	96.47	95.52	94.44	93.21	91.78	90.12
25 €/certificate		97.74	96.79	95.73	94.54	93.20	91.65	89.88	87.80
30 €/certificate	3	98.13	97.40	96.58	95.66	94.61	93.42	92.04	90.43
35 €/certificate		97.92	97.06	96.10	95.03	93.81	92.42	90.81	88.93
40 €/certificate		97.70	96.72	95.63	94.40	93.01	91.41	89.58	87.43
30 €/certificate	4	97.61	96.58	95.44	94.16	92.70	91.03	89.11	86.87
35 €/certificate		97.30	96.11	94.78	93.28	91.58	89.64	87.39	84.78
40 €/certificate		97.00	95.64	94.11	92.40	90.46	88.24	85.67	82.69
30 €/certificate	5	97.40	96.27	95.00	93.57	91.95	90.10	87.97	85.48
35 €/certificate		97.07	95.74	94.26	92.60	90.71	88.55	86.06	83.16
40 €/certificate		96.73	95.22	93.52	91.62	89.46	87.00	84.15	80.83
<b>Increase of the selling price, %</b>									
15 €/certificate	0	100.22	100.28	100.34	100.41	100.49	100.58	100.68	100.80
20 €/certificate		100.26	100.33	100.41	100.50	100.61	100.73	100.86	101.02
25 €/certificate		100.29	100.38	100.48	100.60	100.73	100.88	101.05	101.25
15 €/certificate	1	100.26	100.34	100.43	100.52	100.63	100.76	100.90	101.07
20 €/certificate		100.31	100.41	100.53	100.65	100.80	100.96	101.16	101.38
25 €/certificate		100.35	100.48	100.62	100.78	100.97	101.17	101.41	101.69
15 €/certificate	2	100.28	100.36	100.46	100.57	100.69	100.83	100.99	101.17
20 €/certificate		100.33	100.44	100.57	100.71	100.87	101.06	101.27	101.52
25 €/certificate		100.38	100.52	100.68	100.86	101.06	101.29	101.56	101.87
30 €/certificate	3	100.32	100.43	100.55	100.69	100.85	101.03	101.23	101.47
35 €/certificate		100.35	100.48	100.62	100.79	100.97	101.18	101.42	101.70
40 €/certificate		100.39	100.53	100.70	100.88	101.09	101.33	101.60	101.92

Table 5.1 (continued)

30 €/certificate		100.40	100.55	100.72	100.92	101.13	101.38	101.67	102.01
35 €/certificate	4	100.45	100.62	100.82	101.05	101.30	101.59	101.93	102.32
40 €/certificate		100.49	100.69	100.92	101.18	101.47	101.80	102.18	102.63
30 €/certificate		100.43	100.60	100.79	101.00	101.25	101.52	101.84	102.21
35 €/certificate	5	100.48	100.68	100.90	101.15	101.43	101.75	102.13	102.56
40 €/certificate		100.53	100.76	101.01	101.30	101.62	101.99	102.41	102.91
<i>Non-ferrous metals</i>									
<b>Profit reduction, %</b>									
15 €/certificate		49.15	36.33	22.00	5.88	-12.40	-33.28	-57.37	-85.48
20 €/certificate	1	41.56	24.47	5.36	-16.13	-40.49	-68.33	-100.45	-137.92
25 €/certificate		33.97	12.61	-11.27	-38.14	-68.58	-103.38	-143.53	-190.36
30 €/certificate		26.38	0.74	-27.91	-60.14	-96.68	-138.43	-186.60	-242.80
35 €/certificate	4	18.79	-11.12	-44.55	-82.15	-124.77	-173.48	-229.68	-295.24
40 €/certificate		11.20	-22.98	-61.18	-104.16	-152.86	-208.53	-272.75	-347.68
<b>Increase of the selling price, %</b>									
15 €/certificate		102.54	103.18	103.90	104.71	105.62	106.66	107.87	109.27
20 €/certificate	1	102.92	103.78	104.73	105.81	107.02	108.42	110.02	111.90
25 €/certificate		103.30	104.37	105.56	106.91	108.43	110.17	112.18	114.52
30 €/certificate		103.68	104.96	106.40	108.01	109.83	111.92	114.33	117.14
35 €/certificate	4	104.06	105.56	107.23	109.11	111.24	113.67	116.48	119.76
40 €/certificate		104.44	106.15	108.06	110.21	112.64	115.43	118.64	122.38
<i>Chemical industry</i>									
<b>Profit reduction, %</b>									
15 €/certificate		56.44	38.15	17.71	-5.28	-31.34	-61.12	-95.49	-135.58
20 €/certificate	1	45.61	21.23	-6.01	-36.67	-71.41	-111.11	-156.92	-210.36
25 €/certificate		34.78	4.31	-29.74	-68.05	-111.47	-161.09	-218.35	-285.15
30 €/certificate		23.96	-12.60	-53.47	-99.44	-151.54	-211.08	-279.78	-359.94
35 €/certificate	4	13.13	-29.52	-77.19	-130.82	-191.60	-261.07	-341.22	-434.72
40 €/certificate		2.31	-46.44	-100.92	-162.21	-231.67	-311.05	-402.65	-509.51

Table 5.1 (continued)

Increase of the selling price, %									
15 €/certificate		102.31	103.18	104.15	105.25	106.50	107.92	109.56	111.47
20 €/certificate	1	102.82	103.99	105.29	106.75	108.41	110.30	112.49	115.04
25 €/certificate		103.34	104.79	106.42	108.25	110.32	112.69	115.42	118.61
30 €/certificate		103.86	105.60	107.55	109.75	112.23	115.07	118.35	122.18
35 €/certificate	4	104.37	106.41	108.68	111.24	114.14	117.46	121.29	125.75
40 €/certificate		104.89	107.22	109.82	112.74	116.06	119.85	124.22	129.32

## 5.1 Methodology for monitoring of CO<sub>2</sub> emissions from combustion units

### 5.1.1 Methodology for monitoring of combustion emissions, correlated with levels of approach

The emissions of CO<sub>2</sub> from combustion installations shall be calculated by multiplying the energy content of each fuel with an emission factor and an oxidation factor [C6, I3].

The following formula is used for each fuel and activity:

$$\text{Emissions of CO}_2 = AD \times EF \times OF$$

where:

- AD* – Activity Data;
- EF* – Emission Factor;
- OF* – Oxidation Factor.

Activity data are generally expressed as net energy content of the fuel used during the reporting period. The following formula is applied in order to finding out the energy content of the fuel consumed [I3]:

$$\text{Energy Content of Fuel (TJ)} = \text{Fuel Consumed (t or m}^3_{\text{N}}) \times \text{Net Calorific Value of Fuel (TJ or TJ/m}^3_{\text{N}})$$

Using the emission factor expressed in terms of mass or volume (t CO<sub>2</sub>/t or t CO<sub>2</sub>/m<sup>3</sup><sub>N</sub>) the activity data are expressed as the amount of fuel used (t or m<sup>3</sup><sub>N</sub>).

Fuel consumed:

- Tier 1 – Fuel consumed during the reporting period is determined by the operator within a maximum uncertainty of less than ±7.5%, taking into consideration, if applicable, the effect of stock changes;
- Tier 2 – Fuel consumed during the reporting period is determined by the operator within a maximum uncertainty of less than ±5%, taking into consideration, if applicable, the effect of stock changes;
- Tier 3 – Fuel consumed during the reporting period is determined by the operator within a maximum uncertainty of less than ±2.5%, taking into consideration, if applicable, the effect of stock changes;
- Tier 4 – Fuel consumed during the reporting period is determined by the operator within a maximum uncertainty of less than ±1.5%, taking into consideration, if applicable, the effect of stock changes.

Net calorific value:

- Tier 1 – Reference values for each fuel are presented in Table 5.2 [I3];

Table 5.2. Emission factor and net calorific value of various fuels

Fuel type description	EF, t CO <sub>2</sub> /TJ	NCV, TJ/Gg
Crude oil	73.3	42.3
Orimulsion	76.9	27.5
Natural gas liquids	64.1	44.2
Gasoline	69.2	44.3

Table 5.2 (continued)

Kerosene	71.8	43.8
Shale oil	73.3	38.1
Gas/diesel oil	74.0	43.0
Residual fuel oil	77.3	40.4
Liquefied petroleum gases	63.0	47.3
Ethane	61.6	46.4
Naphtha	73.3	44.5
Bitumen	80.6	40.2
Lubricants	73.3	40.2
Petroleum coke	97.5	32.5
Refinery feedstock	73.3	43.0
Refinery gas	51.3	49.5
Paraffin waxes	73.3	40.2
White spirit and industrial spirit	73.3	40.2
Other petroleum products	73.3	40.2
Anthracite	98.2	26.7
Coking coal	94.5	28.2
Other bituminous coal	94.5	25.8
Sub-bituminous coal	96.0	18.9
Lignite	101.1	11.9
Oil shale and tar sands	106.6	8.9
Coke oven coke and lignite coke	107.0	28.2
Gas coke	107.0	28.2
Coal tar	80.6	28.0
Gas works gas	44.7	38.7
Coke oven gas	44.7	38.7
Blast furnace gas	259.4	2.5
Oxygen steel furnace gas	171.8	7.1
Natural gas	56.1	48.0
Industrial wastes	142.9	n.a.
Waste oil	73.3	40.2
Peat	105.9	9.8
Wood/wood waste	0.0	15.6
Primary solid biomass	0.0	11.6
Charcoal	0.0	29.5
Biogasoline	0.0	27.0
Biodiesel	0.0	27.0
Other liquid biofuels	0.0	27.4
Landfill gas	0.0	50.4
Sludge gas	0.0	50.4
Other biogas	0.0	50.4
<i>Other sources:</i>		
Used tyres/rubbers	85.0	n.a.
Carbon monoxide	155.2	10.1
Methane	54.9	50.0

- Tier 2 (a) – The operator applies to respective fuel, the country specific net calorific value, which is reported by the Member State in its latest national inventory report presented to the secretariat of the UNFCCC;
- Tier 2 (b) – For commercialized fuels shall be used the net calorific value resulted from the verbal processes. This value should be obtained on the basis of national and international standards;

- Tier 3 – The operator or supplier of the fuel shall determine the net calorific value of fuel through an accredited lab ISO 17025.

Emission factor:

- Tier 1 – Emission factors are given in Table 5.2 [I3];
- Tier 2 (a) – The operator applies to respective fuel, the country specific emission factor, which is reported by the Member State in its latest national inventory report presented to the secretariat of the UNFCCC;
- Tier 2 (b) – The operator shall determine, for each fuel, the emission factor based on the following indicators: measurement of the density of petroleum products or used gas (for instance in refineries and steel industry) and specific calorific value of some types of coal.
- Tier 3 – Specific emission factors of each fuel are determined in an accredited lab ISO 17025.

Oxidation factor:

The operator can choose a suitable level of the monitoring method.

- Tier 1 – It is used an oxidation factor of 1.0;
- Tier 2 – The operator applies to respective fuel oxidation factors specified by the Member State in its latest national inventory report presented to the secretariat of the UNFCCC;
- Tier 3 – In case of fuels, the operator shall determine the activity specific factors based on the carbon content of ash, residue and other wastes and byproducts, as well as carbon content of gaseous fuels. Composition data are determined by an accredited lab ISO 17025.

### 5.1.2 Methodology for monitoring of process emissions, correlated with levels of approach

The emissions of CO<sub>2</sub> from the use of carbonate in flue gas desulphurization units shall be calculated on the basis of purchased carbonate (Tier 1 (a)) or gypsum product (Tier 1 (b)). These methods are equivalent. The calculation is as follows [C6, I3]:

$$\text{Emissions of CO}_2 \text{ (t)} = AD \times EF$$

Method A (based on carbonate): Calculation of emissions is based on the amount of carbonate used.

Activity data:

- Tier 1 – Tons of dry carbonate, in the form of input material in the process, used during the reporting period is determined by the operator within a maximum uncertainty of less than ±7.5%;

Emission factor:

- Tier 1 – Emission factor is calculated and reported in units of mass of CO<sub>2</sub> released per ton of carbonate. Stoichiometric ratios presented in Table 5.3 are used to convert composition data into emission factors [I3]. Best practice industrial guidelines are used to determine the amount of CaCO<sub>3</sub> and MgCO<sub>3</sub> in each relevant raw material.

Table 5.3. Stoichiometric ratios

Carbonate	Ratio, t CO <sub>2</sub> /t (Ca, Mg)	Observations
CaCO <sub>3</sub>	0.440	-
MgCO <sub>3</sub>	0.522	-
Generally: X <sub>Y</sub> (CO <sub>3</sub> ) <sub>Z</sub>	EF = M(CO <sub>2</sub> ) / (Y × M(X) + Z × M(CO <sub>3</sub> <sup>2-</sup> ))	X – alkaline earth metal or alkaline M(X) – molecular weight of component X (g/mol) M(CO <sub>2</sub> ) – molecular weight of CO <sub>2</sub> = 44 (g/mol) M(CO <sub>3</sub> <sup>2-</sup> ) – molecular weight of CO <sub>3</sub> <sup>2-</sup> = 66 (g/mol) Y – stoichiometric number of X (1 for alkaline earth metals and 2 for alkaline metals) Z – stoichiometric number of CO <sub>3</sub> <sup>2-</sup> = 1

Method B (based on gypsum): Calculation of emissions is based on the amount of gypsum produced.

Activity data:

- Tier 1 – Tons of dry gypsum (CaSO<sub>4</sub>·2H<sub>2</sub>O) produced per year is determined by the operator or gypsum producer within a maximum uncertainty of less than ±7.5%;

Emission factor:

- Tier 1 – Stoichiometric ratio of dry gypsum (CaSO<sub>4</sub>·2H<sub>2</sub>O) and CO<sub>2</sub> from the process is 0.2558 t CO<sub>2</sub>/t gypsum.

## 5.2 Mathematical formulae

Calculation of fuel consumption, by type of fuel for each year.

$$B_{av\ fuel\ X} = \sum B_X$$

where:

- $B_{av\ fuel\ X}$  – Average fuel consumption for fuel X (oil, natural gas, lignite);  
 $B_X$  – Annual fuel consumption, by type.

CO<sub>2</sub> emissions calculation as average for four years, taking into consideration the period 2009-2012 [I3]:

$$CEco\ (t\ CO_2/year) = \sum (fuel\ consumption\ X\ (TJ/year) \times carbon\ emission\ factor\ (t\ C/TJ)) \times oxidation\ factor\ depending\ on\ fuel\ type \times 44/12$$

where:

- $CEco$  – Carbon emissions from operation.

Calculation of CO<sub>2</sub> emissions equivalent of N<sub>2</sub>O as average for four years, taking into consideration the period 2009-2012 [I3]:

$$CeN_2OEco\ (t\ CO_2\text{-eq}/year) = \sum (fuel\ consumption\ X\ (TJ/year) \times N_2O\ emission\ factor\ (t\ N_2O/TJ)) \times GWP$$

where:

- $CeN_2OEco$  – Emissions of CO<sub>2</sub> equivalent of N<sub>2</sub>O from operation;  
 $GWP$  – Global warming potential.



Calculation of CO<sub>2</sub> emissions equivalent of CH<sub>4</sub> from operation as average for four years, taking into consideration the period 2009-2012 [I3]:

$$CeCH_4Eco \text{ (t CO}_2\text{-eq/year)} = \Sigma (\text{fuel consumption X (TJ/year)} \times \text{CH}_4 \text{ emission factor (t CH}_4\text{/TJ)}) \times \text{GWP}$$

where:

$CeCH_4Eco$  – Emissions of CO<sub>2</sub> equivalent of CH<sub>4</sub> from operation.

Cost estimation for each representative installation is shown in Table 5.4:

Table 5.4. Formulae for calculation of costs

Installation No.	ETS type of activity	Formulae
Installation No. 1 (production of electricity)	Combustion installations with a rated thermal input exceeding 20 MW (except hazardous or municipal waste installations)	Cost produced by CO <sub>2</sub> = Cost of production with ETS – Initial cost*  Cost of production with ETS = Total costs with ETS / Physical production of installation  Total costs with ETS = Costs with purchased allowances + Total costs + Other costs caused by ETS (Additional costs with emission allowances trading and monitoring)  Costs with purchased allowances = Number of allowances to be purchased + Price of certificate**
Installation No. 2 (production of electricity and heat)	Combustion installations with a rated thermal input exceeding 20 MW (except hazardous or municipal waste installations)	Same as for Installation No. 1
Installation No. 3 (oil refining)	Installations for oil refining	Same as for Installation No. 1  Also: Additional costs with allowances purchased for electrical energy used = Specific consumption of electrical energy for one ton of product × Increase of the price of electrical energy caused by ETS
Installation No. 4 (production of ferrous metals)	Installations for the production of pig iron or steel (primary or secondary fusion) including continuous casting, with a capacity exceeding 2.5 t/h	Same as for Installation No. 3

\*at a certain moment

\*\*price of certificate at a certain moment

Table 5.4 (continued)

Installation No. 5 (production of cement clinker)	Installations for the production of cement clinker in rotary kilns with a production capacity exceeding 500 t/day	Same as for Installation No. 3
Installation No. 6 (production of lime)	Installations for the production of lime in rotary kilns or in other furnaces with a production capacity exceeding 50 t/day	Same as for Installation No. 3
Installation No. 7 (manufacture of glass and glass fibre)	Installations for the manufacture of glass including glass fibre with a melting capacity exceeding 20 t/d	Same as for Installation No. 3
Installation No. 8 (manufacture of ceramic products)	Installations for the manufacture of ceramic products by firing, in particular roofing tiles, bricks, refractory bricks, tiles, stoneware or porcelain: (i) with a production capacity exceeding 75 t/day; and/or (ii) with a kiln capacity exceeding 4 m <sup>3</sup> and with a setting density per kiln exceeding 300 kg/m <sup>3</sup>	Same as for Installation No. 3
Installation No. 9 (production of paper and board)	Industrial plants for the production of: (i) pulp from timber or other fibrous materials; and (ii) for the production of paper and board with a production capacity exceeding 20 t/day	Same as for Installation No. 3
Installation No. 10 (chemical)	Combustion units with a total rated thermal input exceeding 20 MW and a production capacity exceeding 50 t/day	Same as for Installation No. 3

## 6 Carbon dioxide capture and storage

### 6.1 Greenhouse gas emissions

Human activities result in emissions of four long-lived greenhouse gases (GHG): carbon dioxide (CO<sub>2</sub>), methane (CH<sub>4</sub>), nitrous oxide (N<sub>2</sub>O) and halocarbons. The atmospheric concentration of these gases increases when emissions are larger than removal processes [D1, H3, I1, I2, I3].

Figure 6.1 shows a breakdown of global anthropogenic greenhouse gas emissions by each gas measured on a CO<sub>2</sub>-equivalent basis [I1, I2].

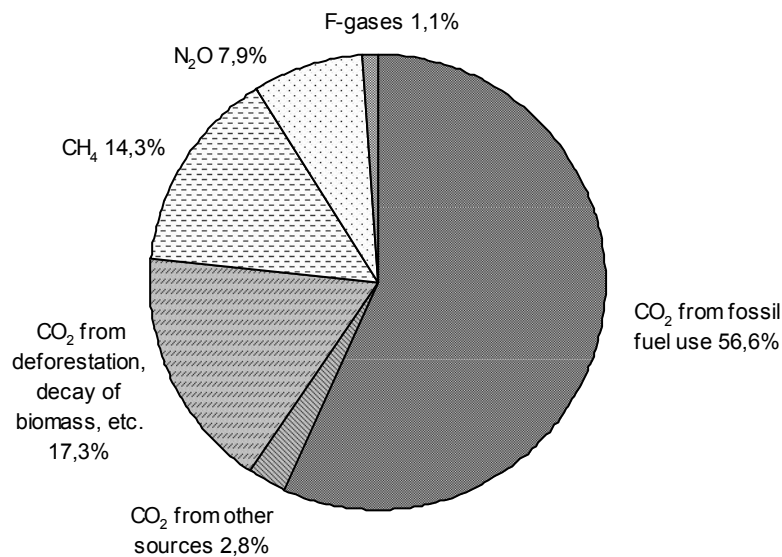

Figure 6.1. Global anthropogenic greenhouse gas emissions in 2004

As seen from Figure 6.1, carbon dioxide is the most important anthropogenic GHG. Its annual emissions have grown between 1970 and 2004 by about 80% (from 21 to 38 billion tonnes) and represented ~77% of total anthropogenic GHG emissions in 2004 [D2, I1, I2].

The global atmospheric concentration of CO<sub>2</sub> increased from a pre-industrial value of about 280 ppm to 390 ppm in 2010 [T1].

The major source of anthropogenic CO<sub>2</sub> is the combustion of fossil fuels, which supply over 80% of the world's energy needs. In 2007, about 29 billion tonnes of carbon dioxide were from fossil fuel combustion (more than 47% as compared to 1990) [H3, I4, I5]. Energy sector emitted almost 41% of the global CO<sub>2</sub> emissions (compared to 27% in 1971), followed by transport and industry, Figure 6.2. Fossil fuels provided over 70% of the world electricity and heat generation, of which coal supplied 41% of the generation [I4, I5].

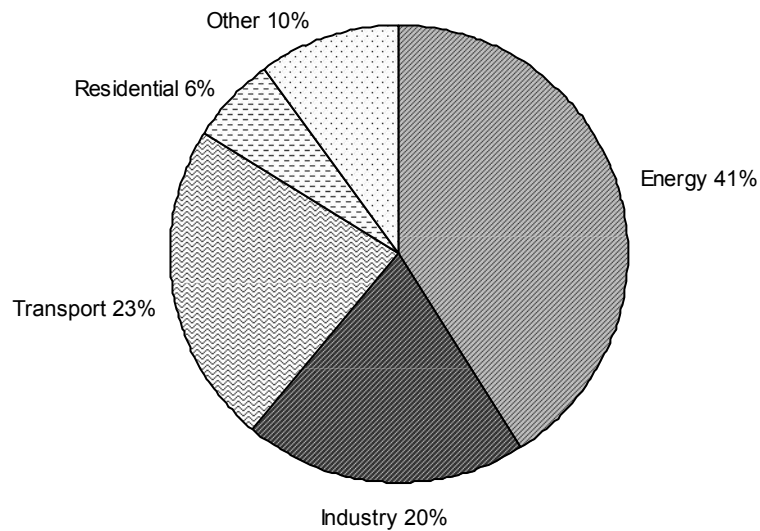

Figure 6.2. World CO<sub>2</sub> emissions by sector in 2007

Though coal represented only a quarter of the world total primary energy supply in 2007, it accounted for 42% of the global CO<sub>2</sub> emissions due to its heavy carbon content per unit of energy released. Figure 6.3 shows the emissions of CO<sub>2</sub> from fossil fuel combustion broken down by fuel type [I4, I5].

Romania emitted nearly 92 million tonnes of CO<sub>2</sub> in 2007 from fossil fuel combustion (with 51% less than in 1989) [I4]. About 29% of these emissions came from the use of coal for electricity generation.

Emissions of CO<sub>2</sub> resulting from the use of fossil fuels can be reduced by means of several measures [H3, I1]:

- to improve/increase the efficiency of power plants and production processes;
- to reduce the energy demand;
- to use low carbon content fuels and to increase the use of renewable energy source; and,
- to apply CO<sub>2</sub> capture and storage.

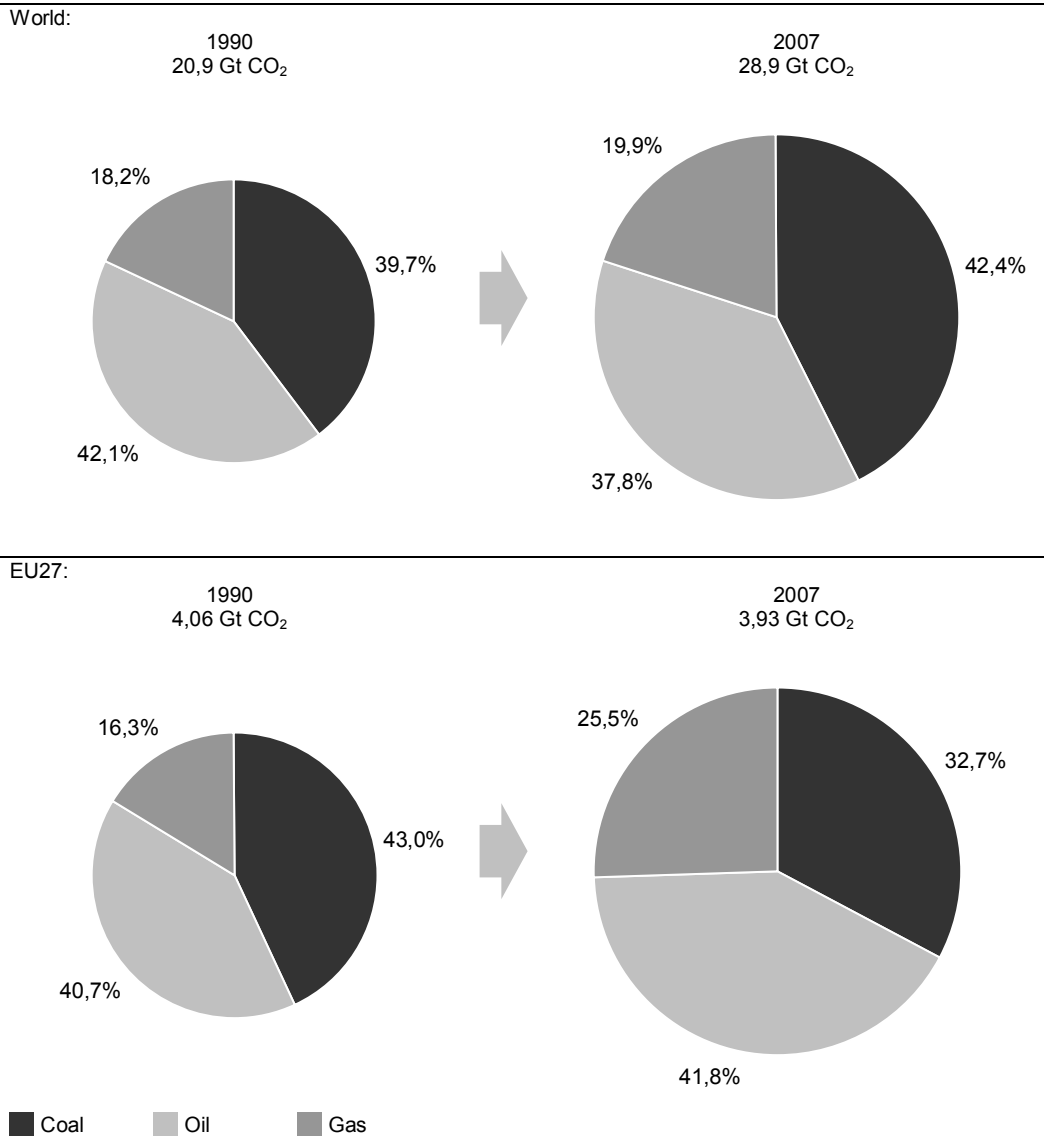
Figure 6.3. World and EU27 emissions of CO<sub>2</sub> in 2007, by fuel

## 6.2 CO<sub>2</sub> capture

There are three main technology options to capture CO<sub>2</sub> produced in large power plants [I1, I6, F2]:

- Post-combustion, CO<sub>2</sub> is separated from the flue gas after combustion of the fuel in air [B3, G1, L3, L4];
- Oxy-fuel combustion, CO<sub>2</sub> is practically the only product after combustion in almost pure oxygen and recycled flue gas, instead of in air [S2];
- Pre-combustion, CO<sub>2</sub> is removed from the fuel before combustion [L1, L2, M2].

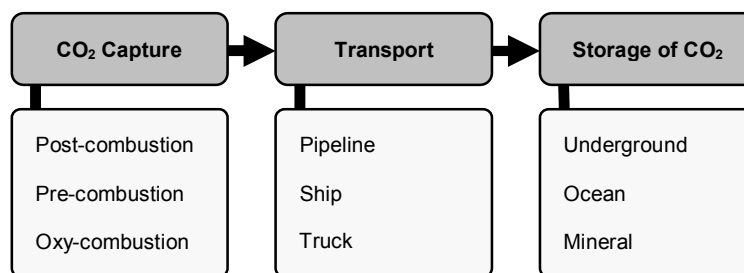

Figure 6.4. Capture, transportation and storage of CO<sub>2</sub>

### 6.2.1 Post-combustion CO<sub>2</sub> capture

Post-combustion capture normally uses a solvent to capture CO<sub>2</sub> from the flue gas of power plants [I1, F2]. The solvent is then regenerated. The solvents for CO<sub>2</sub> capture can be physical, chemical or intermediate but chemical solvents, known as amines, are most likely to be used for post-combustion capture. This is because chemical solvents are less dependent on partial pressure than physical solvents are, and the partial pressure of CO<sub>2</sub> in the flue gas is low, typically 4-14% by volume. However, chemical solvents require more energy (as steam) to regenerate, that is, to break the relatively strong chemical link between CO<sub>2</sub> and the solvent.

It is likely that amines will be used for the first generation of CO<sub>2</sub> post-combustion capture, because of the advanced state of development of amine absorption. However, the presence of oxygen can be a problem for flue gas amine scrubbing, as it can cause degradation of some solvents and corrosion of equipment. Inhibitors can be included in the solvent to counteract the activity of oxygen. At present the process of scrubbing CO<sub>2</sub> with amines does not operate on the scale of power plants, but increasing the technology to this size is not considered to be a major problem.

The flue gas must contain very low levels of oxides of nitrogen and sulphur (NO<sub>x</sub> and SO<sub>x</sub>) before it is scrubbed of CO<sub>2</sub>. This is because NO<sub>2</sub> and SO<sub>2</sub> react with the amine to form stable, non-regenerable salts, and so cause a steady loss of the amine. The preferred SO<sub>2</sub> specification is usually set at between 1 and 10 ppm. This means that post-combustion CO<sub>2</sub> capture on coal fired power plants requires upstream de-NO<sub>x</sub> and flue gas desulphurization (FGD) facilities. The limits for NO<sub>x</sub> can usually be met by the use of low NO<sub>x</sub> burners with selective catalytic reduction (SCR), and the SO<sub>x</sub> limit can be achieved by some FGD technologies.

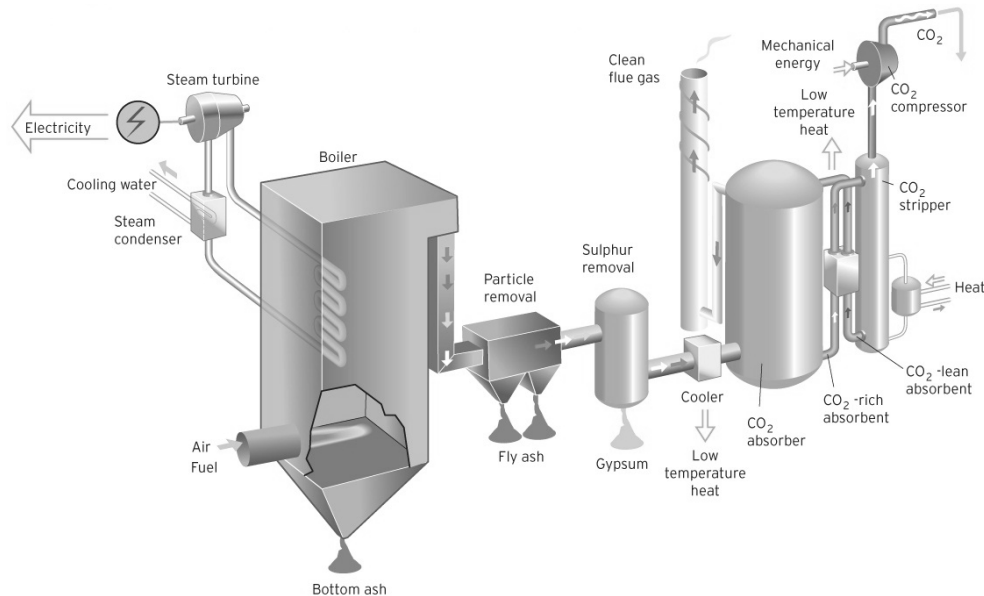

Figure 6.5. Post-combustion CO<sub>2</sub> capture (absorption process)

Figure 6.5 shows a general schematic of a coal-fired power plant in which additional unit operations are deployed to remove the air pollutants prior to CO<sub>2</sub> capture in an absorption-based process [V1].

Three absorption processes are commercially available for CO<sub>2</sub> capture in post-combustion systems [I1]:

- The Kerr-McGee/ABB Lummus Crest Process, this process recovers CO<sub>2</sub> from coke and coal-fired boilers, delivering CO<sub>2</sub> for soda ash and liquid CO<sub>2</sub> preparations. It uses a 15-20% by weight aqueous MEA solution;
- Fluor's Econamine FG Plus<sup>SM</sup> process, which is a MEA-based process (30% by weight aqueous solution) with an inhibitor to resist carbon steel corrosion and is specifically tailored for oxygen-containing gas streams;
- KEPCO/MHI process is based upon sterically-hindered amines and already three solvents (KS-1, KS-2 and KS-3) have been developed. KS-1 was commercialized in a urea production application. In this process, low amine losses and low solvent degradation have been noted without the use of inhibitors or additives.

In these processes flue gas is contacted with CO<sub>2</sub>-lean amine solvent, which removes up to 90% of the CO<sub>2</sub>. The CO<sub>2</sub>-rich amine is passed to a stripper vessel, where it is regenerated to release CO<sub>2</sub>. Heat for the regeneration is provided by low-pressure steam extracted from the steam turbine.

The Econamine FG Plus<sup>SM</sup> process is a modification of the Econamine FG<sup>SM</sup> process, which is in operation at commercial plants that produce CO<sub>2</sub> mainly for enhanced oil recovery, chemicals production and the food industry. The Econamine FG Plus<sup>SM</sup> process includes a split flow configuration, an improved solvent formulation and other features which reduce the energy consumption. No commercial scale Econamine FG Plus<sup>SM</sup> plants are currently operating but the process is being offered commercially by Fluor. A KS-1 plant in Malaysia which

captures about 200 t/day of CO<sub>2</sub> from reformer flue gas has been operating since 1999. Fluor and MHI's existing capture units are at gas fired plants but 150-200 t/day capture units based on the ABB Lummus Global/Kerr McGee MEA scrubbing process are operating at two coal-fired power plants in the USA.

As said earlier, the flue gas input to a CO<sub>2</sub> solvent scrubbing unit has to have low concentrations of SO<sub>2</sub> and NO<sub>2</sub>, as these substances result in loss of solvent. The SO<sub>2</sub> specification is set at 10 ppm by Fluor and 1 ppm by MHI. These concentrations are lower than from typical plants without capture but they can be achieved by some current FGD technologies. The SCR unit included in the coal-fired plants in this assessment produces a flue gas with a NO<sub>2</sub> concentration to 5 ppm, well within the limits set by the amine scrubbing unit suppliers.

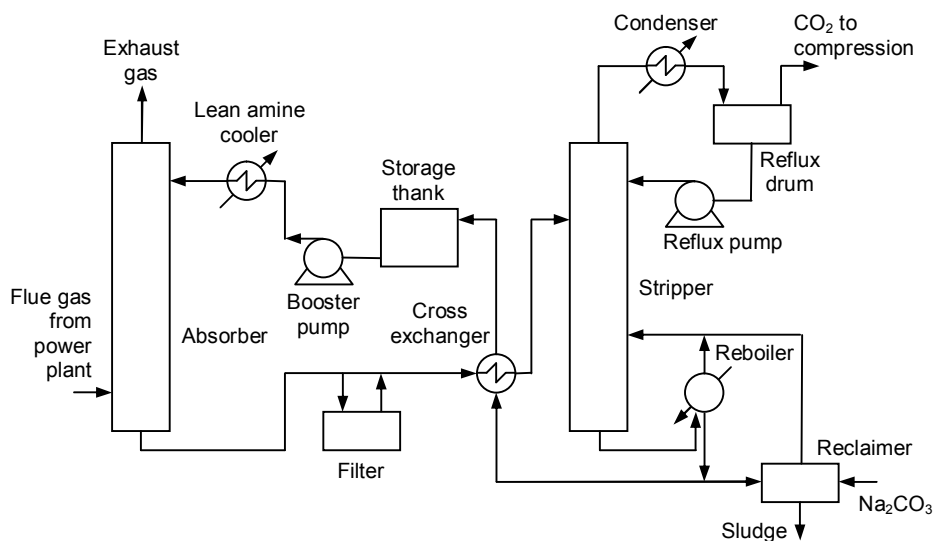

Figure 6.6. Process flow diagram for a typical amine separation process

As shown in Figure 6.6, which depicts a typical process flowsheet, flue gas contacts the MEA solution in an absorber. The MEA selectively absorbs the CO<sub>2</sub> and is then sent to a stripper. In the stripper, the CO<sub>2</sub>-rich MEA solution is heated to release almost pure CO<sub>2</sub>. The CO<sub>2</sub>-lean MEA solution is then recycled to the absorber.

Currently, there are being developed new post-combustion CO<sub>2</sub> capture technologies based on [F2]:

- Amine-enhanced sorbents, being developed by National Energy Technology Laboratory (NETL). The principle of operation of the process entails exposing a CO<sub>2</sub>-rich stream to a carbon material with amine compounds attached unto it. The CO<sub>2</sub> absorbed on the amine sites is subsequently released upon increasing the temperature. This process has some advantages over the MEA process (e.g., higher CO<sub>2</sub> carrying capacity, lower heat capacity, as there is no water to heat). One technical challenge is that small particle diameters can cause high-pressure drops across the absorber;



- Aqueous ammonia, which reacts with CO<sub>2</sub> in the flue gas to form ammonium carbonate, and subsequently heating the ammonium carbonate to release a pure CO<sub>2</sub> stream. Advantages include: low theoretical heat of regeneration; and, multi-pollutant control with saleable by-products. One technical challenge is degradation of carbonate in the CO<sub>2</sub> absorber leading potentially to ammonia slip in the flue gas.
- Chilled ammonia, being developed by Alstom, entails chilling the flue gas, recovering large quantities of water for recycle, and then utilizing a CO<sub>2</sub> absorber similar in design to the absorbers used in systems to reduce flue gas sulfur dioxide emissions. CO<sub>2</sub> is stripped at high pressure and compressed to a pressure suitable for use in enhanced oil recovery (EOR) or sequestration. In laboratory tests, the process has demonstrated a potential for capturing more than 90% CO<sub>2</sub> at an efficiency penalty that is much lower than other CO<sub>2</sub> capture technologies.

### 6.2.2 Oxy-fuel combustion

The oxy-fuel combustion process eliminates nitrogen from the flue gas by combusting a hydrocarbon or carbonaceous fuel in either pure oxygen or a mixture of pure oxygen and a CO<sub>2</sub>-rich recycled flue gas [I1, I6]. Figure 6.7 shows a schematic of an oxy-fuel pulverized coal-fired power plant [V1].

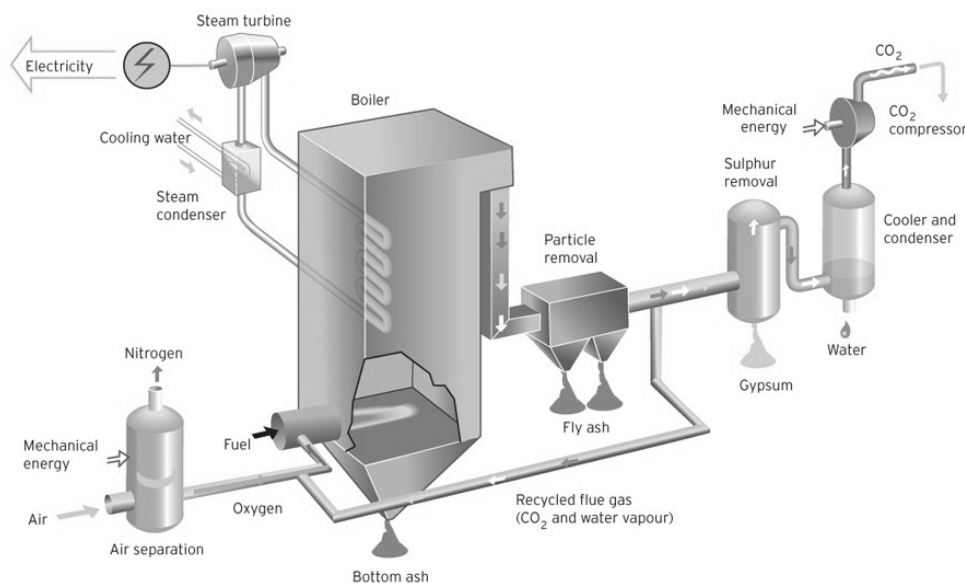

Figure 6.7. Oxy-combustion CO<sub>2</sub> capture (O<sub>2</sub>/CO<sub>2</sub> recycle)

Combustion of a fuel with pure oxygen has a combustion temperature of about 3500°C which is far too high for typical power plant materials. The combustion temperature is limited to about 1300-1400°C in a typical gas turbine

cycle and to about 1900°C in an oxy-fuel coal-fired boiler using current technology. About two-thirds of the cooled flue gas is recycled to the boiler to avoid excessively high temperatures.

The PC oxy-combustion plant uses the same steam conditions as the other post-combustion capture plant. A large amount of oxygen is required for combustion, which is obtained from an air separation unit (ASU). The flue gas from oxy-combustion is compressed and chilled to separate out nitrogen, oxygen and other impurities. The resulting CO<sub>2</sub> concentration is typically 95 mol% or more.

Vattenfall built a 30 MW<sub>th</sub> pulverized coal demonstration plant next to the existing lignite-fired 1600 MW Schwarze Pumpe power plant in Germany, for which Alstom is supplying the oxy-boiler technology [S2, V1].

Economic evaluations show that purifying the flue gas from oxygen-fired systems can be competitive with extracting the CO<sub>2</sub> from air-fired systems with advanced post-combustion technologies and would cost less than today's commercial amine technologies.

The oxygen can be supplied by a cryogenic air separation unit or in the future by more efficient processes such as oxygen transport membranes. Today's cryogenic air separation plants typically require electrical inputs of up to 18% of the power plant's gross electrical output.

### 6.2.3 Pre-combustion CO<sub>2</sub> capture

In this process, a fuel is reacted with air or oxygen to produce a stream that contains carbon monoxide (CO) and hydrogen (H<sub>2</sub>) [I1, I6]. This is then reacted with steam in a shift reactor to produce a mixture of CO<sub>2</sub> and H<sub>2</sub>. The CO<sub>2</sub> is separated and the H<sub>2</sub> is used as the fuel in a gas turbine combined cycle, which is the most efficient thermal cycle for power generation, currently.

Figure 6.8 shows a schematic of a pre-combustion CO<sub>2</sub> capture system [V1].

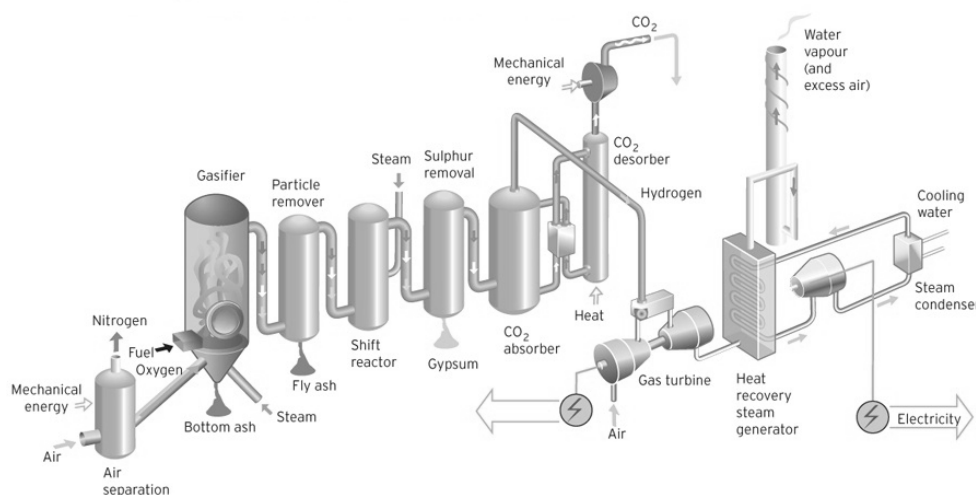

Figure 6.8. Pre-combustion CO<sub>2</sub> capture (decarbonisation process)

The concentration of CO<sub>2</sub> in the input to the CO<sub>2</sub>/H<sub>2</sub> separation stage can be in the range 15-60% (dry basis) and the total pressure is typically 2-7 MPa. The separated CO<sub>2</sub> is then available for storage.

Pre-combustion capture can be used in natural gas or coal based plants. When the primary fuel is coal, and the key process is the gasification of the coal, it is known as an integrated gasification combined cycle (IGCC). Gasification is the partial oxidation of coal, or any fossil fuel to a gas, often known as syngas, which has H<sub>2</sub> and CO as its main components. Gasification can act as a bridge between coal and gas turbines, with the target of high energy efficiency and minimum emissions to the environment. However, at present, none of the existing coal-fired IGCC plants includes shift conversion with CO<sub>2</sub> capture.

International Energy Agency (IEA) has assessed plants based on two types of gasifier: (i) a slurry feed gasifier, in which the gas product is cooled by quenching with water; and, (ii) a dry feed gasifier, in which the gas product is cooled in a heat recovery boiler.

In the slurry feed IGCC plant without CO<sub>2</sub> capture, the coal is ground and slurried with water and then pumped to the gasifier vessels where it reacts with oxygen. The products from gasification are quenched with water, the saturated gas is cooled, and condensed water and minor impurities are removed. The sulphur compounds are removed from the gas by passing it through a reactor and feeding it to a selexol acid gas removal plant (selexol is a physical solvent). The clean fuel gas is fed to the gas turbine combined cycle plant.

However, in the case of the IGCC with CO<sub>2</sub> capture, the gas from the gasifier is fed to a CO<sub>2</sub>-shift converter prior to cooling and the selexol unit removes CO<sub>2</sub> as well as sulphur compounds. The Selexol is regenerated to produce separate CO<sub>2</sub> and sulphur compound streams. The CO<sub>2</sub> stream is compressed and dried for transport by pipeline. The removal rate of CO<sub>2</sub> is over 90%, which means that an overall CO<sub>2</sub> capture rate of 85% can be achieved.

In the dry feed gasifier plant without capture of CO<sub>2</sub>, the coal is dried, ground and then fed to the gasifier vessels. The gasifier product gas is quenched, cooled and is then fed to a dry particulate removal unit. Some of the gas is recycled as quench gas and the remainder is scrubbed with water, reheated, the carbonyl sulfide (COS) is removed and it is fed to a methyldiethanolamine (MDEA) solvent acid removal plant. The clean fuel gas is fed to the gas turbine combined cycle plant. The configuration of the plant with CO<sub>2</sub> capture is the same except that the COS removal process is replaced by a two-stage shift converter and hydrogen sulfide (H<sub>2</sub>S) and CO<sub>2</sub> are separated in a selexol acid gas removal unit.

### 6.3 CO<sub>2</sub> emissions from power plant

In Table 6.1 is shown and compared the amount of CO<sub>2</sub> emitted and captured from different power plants based on coal and natural gas [I1]. Power generation technologies with and without capture of CO<sub>2</sub> considered are: pulverized coal (PC), integrated coal gasification combined cycle (IGCC, dry and slurry feed) and natural gas combined cycle (NGCC).

Table 6.1. CO<sub>2</sub> emissions from fossil fuel power plants

Power generation technology	CO <sub>2</sub> capture technology	CO <sub>2</sub> emissions, g/kWh	CO <sub>2</sub> captured, g/kWh	CO <sub>2</sub> captured, %
PC	None	743	-	-
	Post-combustion (MHI)	92	832	90
	Post-combustion (Fluor)	117	822	87,5
	Oxy-combustion	84	831	90,8
IGCC (dry)	None	763	-	-
	Pre-combustion (Selexol)	142	809	85
IGCC (slurry)	None	833	-	-
	Pre-combustion (Selexol)	152	851	84,8
NGCC	None	379	-	-
	Post-combustion (MHI)	63	362	85,2
	Post-combustion (Fluor)	66	378	85
	Oxy-combustion	12	403	97

It is clearly shown in Table 6.1 that coal-based power plants have the highest output rate of CO<sub>2</sub> per kilowatt-hour produced. Use of any CO<sub>2</sub> capture technology may capture CO<sub>2</sub> in the range of 85-90% for the post-combustion power plants, 85% for pre-combustion and 90-97% for oxy-combustion. These are not necessarily the technical limits or economic optima for each of the technologies. For example, increasing the percentage CO<sub>2</sub> capture in coal-based post-combustion capture from 85-95% is reported to reduce the cost per tonne of CO<sub>2</sub> captured by 2%.

The plants do not all produce the same purity of CO<sub>2</sub>. Some technologies inherently produce high-purity CO<sub>2</sub> but others inherently produce lower purity CO<sub>2</sub> which has to be refined if a higher purity is required. The relative merits of the technologies therefore depend on the CO<sub>2</sub> purity requirements.

#### 6.4 Efficiency of a power plant with CO<sub>2</sub> capture

The thermal efficiencies of power plants with and without CO<sub>2</sub> capture are compared in Table 6.2.

Table 6.2. Thermal efficiency of power plants with and without CO<sub>2</sub> capture

Power generation technology	CO <sub>2</sub> capture technology	Net efficiency, % (LHV)
PC	None	44
	Post-combustion (MHI)	35,3
	Post-combustion (Fluor)	34,8
	Oxy-combustion	35,4
IGCC (dry feed)	None	43,1
	Pre-combustion (Selexol)	34,5
IGCC (slurry feed)	None	38
	Pre-combustion (Selexol)	31,5
NGCC	None	55,6
	Post-combustion (MHI)	49,6
	Post-combustion (Fluor)	47,4
	Oxy-combustion	44,7

The pulverized coal plant without CO<sub>2</sub> capture has a net efficiency of 44%, which is similar to the 43.1% efficiency of the dry feed IGCC plant. The dry feed IGCC plant has a significantly higher efficiency than the slurry feed IGCC plant (38%), mainly because of a higher efficiency of conversion of coal to fuel gas in the gasifier and the use of a heat recovery boiler instead of water quench to cool the output from the gasifier. As expected, the natural gas-fired plant without capture has a substantially higher thermal efficiency, 55.6%.

The efficiencies of the post-combustion capture, dry feed IGCC and oxy-combustion coal fired plants with capture are similar, 34.5-35.4%. The efficiency reductions for CO<sub>2</sub> capture compared to the same type of plant without capture are 8.6-9.2 percentage points. The slurry feed IGCC plant with capture has a lower efficiency, 31.5% but it also has a lower-efficiency reduction compared to the same type of plant without capture (6.5 percentage points). The efficiency of the slurry feed IGCC plant with capture is 12.5 percentage points lower than that of the reference pulverized coal plant without capture. The efficiencies of the NGCC plants with post-combustion capture are 47.4-49.6% and the efficiency reduction for CO<sub>2</sub> capture is 6-8.2 percentage points. The oxy-combustion NGCC plant has a lower efficiency, 44.7%.

The factors which contribute to the efficiency reductions for CO<sub>2</sub> capture for each fuel and technology are as follows:

For post-combustion capture, more than half of the efficiency reduction is due to the use of low-pressure steam for CO<sub>2</sub> capture solvent regeneration. The energy losses are lower for MHI's process because the heat consumption for regeneration of the KS-1 solvent is lower than for MEA and the flue gas fan power consumptions are lower, partly due to the use of structured instead of random packing in the absorber. The efficiency reduction for post-combustion capture is lower for the natural gas-fired plants than for the coal-fired plants. The fan power consumptions are higher in the gas-fired plants, because a greater volume of flue gas has to be processed per unit of fuel but the solvent-regeneration heat consumption is lower because less CO<sub>2</sub> has to be captured, because natural gas has a lower carbon content per unit of energy than coal.

The energy losses due to the CO<sub>2</sub> separation units in the IGCC plants are lower than those in the pulverized coal post-combustion capture plants because a less energy intensive physical solvent scrubbing process can be used in IGCC

because the CO<sub>2</sub> partial pressure is higher (5.7 MPa total pressure and 40% CO<sub>2</sub> concentration in the GE gasifier case and 2.8 MPa and 37% CO<sub>2</sub> in the Shell gasifier case). In the post-combustion capture plants the feed gas is close to atmospheric pressure and the CO<sub>2</sub> concentration is lower (14% dry basis in the coal cases and 4.3% in the gas combined cycle cases), which requires use of a more energy intensive chemical solvent. Most of the solvent regeneration in the IGCC plants is carried out by solvent depressurization. The energy consumption for CO<sub>2</sub> compression is also lower in the IGCC plants because some of the CO<sub>2</sub> is recovered at elevated pressures. However, the IGCC plants have additional energy losses which do not occur in the post-combustion capture plants. The fuel gas has to be passed through shift reactors prior to CO<sub>2</sub> removal and the shift reactions are highly exothermic. Even though most of the exothermic heat is recovered in steam generators, this means that energy bypasses the gas turbine and is fed directly into the lower efficiency steam cycle. A further energy loss in IGCC plants with capture is due to the impacts of shift conversion and CO<sub>2</sub> separation on the performance of the gas turbine combined cycle. In plants without capture, CO<sub>2</sub> produced by combustion of the fuel gas is expanded in the gas turbine. In plants with capture the CO<sub>2</sub> is separated and is not available for expansion. The use of a hydrogen-rich fuel gas in the plants with CO<sub>2</sub> capture also has other impacts on the combined cycle performance, in particular the expansion gas has a higher steam concentration, which increases the rate of heat transfer to the turbine blades.

The main efficiency reduction for coal-fired oxy-combustion is due to the electricity consumed by the cryogenic oxygen production unit. This is offset slightly by a small overall reduction in losses in the main power generation units, for example due to deletion of the FGD plant. The energy consumption for CO<sub>2</sub> compression is higher than in the post-combustion capture plant because the volume of gas fed to the CO<sub>2</sub> compressors is higher, due to the presence of impurities, and because some additional compression is required to drive the cryogenic separation unit which removes impurities part way through the CO<sub>2</sub> compression. The energy consumption for CO<sub>2</sub> compression is lower in the oxy-combustion NGCC plant than in the oxy-combustion coal plant because less CO<sub>2</sub> is produced, but the efficiency reduction due to the power generation and oxygen plant is substantially greater, resulting in a greater overall efficiency reduction for capture. The quantity of oxygen required per MW of fuel is about 15% lower in the NGCC plant but the oxygen is produced at high pressure for feeding to the gas turbine, resulting in a higher overall energy consumption.

## 6.5 Transportation of CO<sub>2</sub>

Once captured, cleaned, and compressed, the CO<sub>2</sub> must be transported. Transport in dedicated pipelines is the most promising method for delivering captured CO<sub>2</sub> to storage facilities, though other methods, such as barges or ships for ocean storage, have been suggested [I1]. The oil and gas industry has years of experience with CO<sub>2</sub> pipelines, transporting CO<sub>2</sub> hundreds of kilometers for use in EOR operations. Large-scale CO<sub>2</sub> transport would undoubtedly require the development of additional infrastructure, though there may be limited opportunities to use existing oil and gas pipelines when the fields they serve are retired and converted to storage sites.

## 6.6 Storage of CO<sub>2</sub>

Carbon dioxide captured from large industrial activities can be stored in:

### 6.6.1 Geological formations

- Enhanced oil recovery [I1, I9] – CO<sub>2</sub> injection into geological formations for enhanced oil recovery is a mature technology. In 2000, 84 commercial or research-level CO<sub>2</sub>-EOR projects were operational worldwide. The United States, the technology leader, accounts for 72 of the 84 projects, most of which are located in the Permian Basin. Outside the United States and Canada, CO<sub>2</sub>-EOR projects have been implemented in Hungary, Turkey, and Trinidad;
- Depleted oil and gas reservoirs [I1, I9] – injecting CO<sub>2</sub> into depleted oil and gas fields has been practiced for many years. The major purpose of these injections was to disposing of acid gas, a mixture of CO<sub>2</sub>, H<sub>2</sub>S and other by products of oil and gas exploitation and refining. In 2001, nearly 200 million cubic meters of acid gas was injected into formations across Alberta and British Columbia at more than 30 different locations. Acid gas injection has become a popular alternative to sulfur recovery and acid gas flaring, particularly in Western Canada. Essentially, acid gas injection schemes remove CO<sub>2</sub> and H<sub>2</sub>S from the produced oil or gas stream, compress and transport the gases via pipeline to an injection well, and re-inject the gases into a different formation for disposal. Proponents of acid gas injection claim that these schemes result in less environmental impact than alternatives for processing and disposing unwanted gases. In most of these schemes, CO<sub>2</sub> represents the largest component of the acid gas, typically up to 90% of the total volume injected for disposal. Successful acid gas injection requires a nearby reservoir with sufficient porosity, amply isolated from producing reservoirs and water zones. Historically, depleted and producing reservoirs have proven to be extremely reliable containers of both hydrocarbons and acid gases over time;
- Unmineable coal seams [I1, I9] – abandoned or uneconomic coal seams are another potential storage site. CO<sub>2</sub> diffuses through the pore structure of coal and is physically adsorbed to it. This process is similar to the way in which activated carbon removes impurities from air or water. The exposed coal surface has a preferred affinity for adsorption of CO<sub>2</sub> than for methane with a ratio of 2:1. Thus, CO<sub>2</sub> can be used to enhance the recovery of coal bed methane (CMB). In some cases, this can be very cost effective or even cost free, as the additional methane removal can offset the cost of the CO<sub>2</sub> storage operations. CBM production has become an increasingly important component of natural gas supply in the United States during the last decade. The most significant CBM production, some 85 percent of the total, occurs in the San Juan basin of southern Colorado and northern New Mexico. Another 10 percent is produced in the Black Warrior basin of Alabama, and the remaining 5 percent comes from rapidly developing Rocky Mountain coal basins, namely the Uinta basin in Utah, the Raton basin in Colorado and New Mexico, and the Powder River basin in Wyoming. Significant potential for

CBM exists worldwide. A number of coal basins in Australia, Russia, China, India, Indonesia, and other countries have also been identified as having a large CBM potential. The total worldwide potential for CBM is estimated at around two trillion standard cubic meters, with about 7.1 billion tons of associated CO<sub>2</sub> storage potential;

- Deep saline formations [I1, I9] – both sub-terranean and sub-seabed, may have the greatest CO<sub>2</sub> storage potential. These reservoirs are the most widespread and have the largest volumes. These reservoirs are very distinct from the more familiar reservoirs used for fresh water supplies. Research is currently underway in trying to understand what percentage of these deep saline formations could be suitable CO<sub>2</sub> storage sites.

The density of CO<sub>2</sub> depends on the depth of injection, which determines the ambient temperature and pressure [I7]. The CO<sub>2</sub> must be injected below 800 m, so that it is in a dense phase (either liquid or supercritical). When injected at these depths, the specific gravity of CO<sub>2</sub> ranges from 0.5 to 0.9, which is lower than that of the ambient aquifer brine. Therefore, CO<sub>2</sub> will naturally rise to the top of the reservoir, and a trap is needed to ensure that it does not reach the surface. Geologic traps overlying the aquifer immobilize the CO<sub>2</sub>. In the case of aquifers with no distinct geologic traps, an impermeable cap-rock above the underground reservoir is needed. This forces the CO<sub>2</sub> to be entrained in the groundwater flow and is known as hydrodynamic trapping. Two other very important trapping mechanisms are solubility and mineral trapping. Solubility and mineral trapping involve the dissolution of CO<sub>2</sub> into fluids, and the reaction of CO<sub>2</sub> with minerals present in the host formation to form stable, solid compounds like carbonates. If the flow path is long enough, the CO<sub>2</sub> might all dissolve or become fixed by mineral reactions before it reaches the basin margin, essentially becoming permanently trapped in the reservoir.

The first, and to date only, commercial-scale project dedicated to geologic CO<sub>2</sub> storage is in operation at the Sleipner West gas field, operated by Statoil, located in the North Sea about 250 km off the coast of Norway. The natural gas produced at the field has a CO<sub>2</sub> content of about 9%. In order to meet commercial specifications, the CO<sub>2</sub> content must be reduced to 2.5% percent. At Sleipner, the CO<sub>2</sub> is compressed and injected via a single well into the Utsira Formation, a 250 m thick aquifer located at a depth of 800 m below the seabed. About one million metric tons of CO<sub>2</sub> have been stored annually at Sleipner since October 1996, equivalent to about 3% of Norway's total annual CO<sub>2</sub> emissions. A total of 20 Mt of CO<sub>2</sub> is expected to be stored over the lifetime of the project.

Statoil is planning a second storage project involving about 0.7 Mt per year of CO<sub>2</sub> produced at the Snohvit gas field in the Barents Sea off northern Norway to be injected into a deep sub-sea formation.

### 6.6.2 Ocean storage

By far, the ocean represents the largest potential sink for anthropogenic CO<sub>2</sub>. It already contains an estimated 40000 billion metric tons of carbon compared with only 750 GtC in the atmosphere and 2200 GtC in the terrestrial biosphere [I1, I8]. Apart from the surface layer, deep ocean water is unsaturated with respect to CO<sub>2</sub>. It is estimated that if all the anthropogenic CO<sub>2</sub> that would double the atmospheric concentration were injected into the deep ocean, it would change the ocean carbon concentration by less than 2%, and lower its pH by less than 0.15



units. Furthermore, the deep waters of the ocean are not hermetically separated from the atmosphere. Eventually, on a time scale of 1000 years, over 80% of today's anthropogenic emissions of CO<sub>2</sub> will be transferred to the ocean. Discharging CO<sub>2</sub> directly to the ocean would accelerate this ongoing but slow natural process and would reduce both peak atmospheric CO<sub>2</sub> concentrations and their rate of increase.

In order to understand ocean storage of CO<sub>2</sub>, some properties of CO<sub>2</sub> and seawater need to be elucidated. For efficiency and economics of transport, CO<sub>2</sub> would be discharged in its liquid phase. If discharged above about 500 m depth, that is at a hydrostatic pressure less than 50 atm, liquid CO<sub>2</sub> would immediately flash into a vapor, and bubble up back into the atmosphere. Between 500 and about 3000 m, liquid CO<sub>2</sub> is less dense than seawater, therefore it would ascend by buoyancy. It has been shown by hydrodynamic modeling that if liquid CO<sub>2</sub> were released in these depths through a diffuser such that the bulk liquid breaks up into droplets less than about 1 cm in diameter, the ascending droplets would completely dissolve before rising 100 m. Because of the higher compressibility of CO<sub>2</sub> compared to seawater, below about 3000 m liquid CO<sub>2</sub> becomes denser than seawater, and if released there, would descend to greater depths. When liquid CO<sub>2</sub> is in contact with water at temperatures less than 10°C and pressures greater than 44.4 atm, a solid hydrate is formed in which a CO<sub>2</sub> molecule occupies the center of a cage surrounded by water molecules. For droplets injected into seawater, only a thin film of hydrate forms around the droplets.

There are two primary methods under serious consideration for injecting CO<sub>2</sub> into the ocean. One involves dissolution of CO<sub>2</sub> at mid-depths (1500-3000 m) by injecting it from a bottom mounted pipe from shore or from a pipe towed by a moving CO<sub>2</sub> tanker. The other is to inject CO<sub>2</sub> below 3000 m, where it will form a "deep lake". Benefits of the dissolution method are that it relies on commercially available technology and the resulting plumes can be made to have high dilution to minimize any local environmental impacts due to increased CO<sub>2</sub> concentration or reduced pH. The concept of a CO<sub>2</sub> lake is based on a desire to minimize leakage to the atmosphere. Research is also looking at an alternate option of injecting the CO<sub>2</sub> in the form of bicarbonate ions in solution. For example, seawater could be brought into contact with flue gases in a reactor vessel at a power plant, and that CO<sub>2</sub>-rich water could be brought into contact with crushed carbonate minerals, which would then dissolve and form bicarbonate ions. Advantages of this scheme are that only shallow injection is required (>200 m) and no pH changes will result. Drawbacks are the need for large amounts of water and carbonate minerals.

## 6.7 Costs

### 6.7.1 Costs of power generation with and without CO<sub>2</sub> capture

Capital costs and costs of electricity generation are shown in Figure 6.9 [11]. This figure is based on a coal price of 2.2 \$/GJ and a gas price of 7.8 \$/GJ.

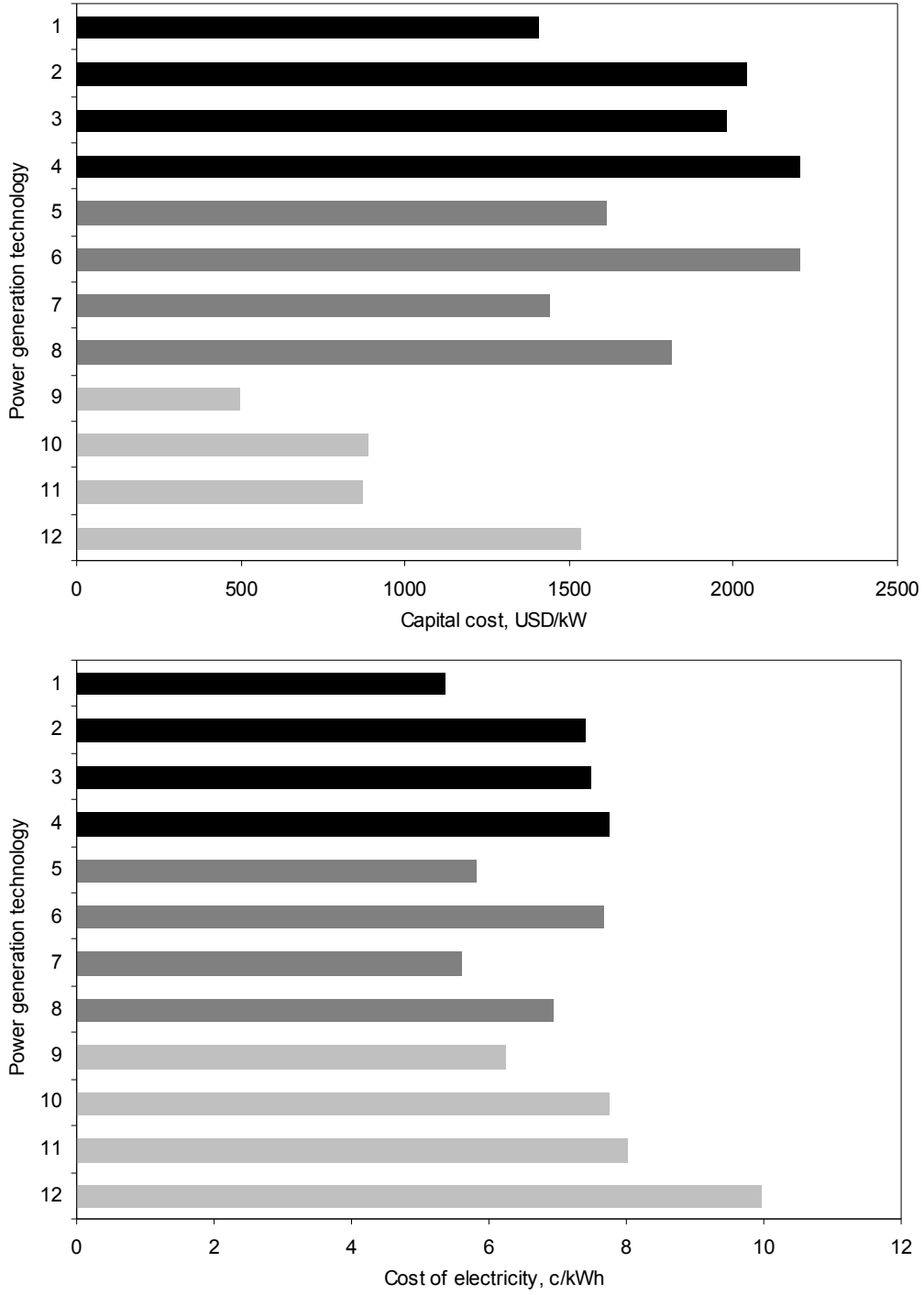

Figure 6.9. Capital costs and cost of electricity for different generation technologies

The following power generation technologies are in Figure 6.9:

- Coal-based power plants:
  - 1 – PC without capture;
  - 2 – PC post-combustion capture (MHI);
  - 3 – PC post-combustion (Fluor);
  - 4 – PC oxy-combustion;
  - 5 – IGCC (dry feed) without capture;
  - 6 – IGCC (dry feed) pre-combustion (Selexol);
  - 7 – IGCC (slurry feed) without capture;
  - 8 – IGCC (slurry feed) pre-combustion (Selexol);
- Natural gas-based power plants:
  - 9 – NGCC without capture;
  - 10 – NGCC post-combustion capture (MHI);
  - 11 – NGCC post-combustion (Fluor);
  - 12 – NGCC oxy-combustion.

The capital costs and costs of electricity generation of the coal-fired plants are similar, and are within the limits of precision of the cost estimates. The lowest cost plant with capture is the IGCC plant. For the base case coal price the cost of electricity generation is 6% lower than that of the lowest cost post-combustion capture plant and 11% lower than the oxy-combustion plant. However, it should be recognized that these studies are based on standardized assumptions about plant performance and availability which have yet to be demonstrated in practice. Costs can also vary significantly for different coals and plant locations and there is significant scope for improvement in all of the technologies considered in this paper, so the cost relativities could change in future.

The cost of electricity generation with CO<sub>2</sub> capture is marginally higher for the natural gas combined cycle plants with post combustion capture than for the coal-based IGCC and post-combustion plants. The cost difference is greater between natural gas and coal based oxy-combustion plants. The natural gas fired oxy-combustion plant has a cost of electricity that is about 25% higher than that of the natural gas post-combustion capture plant. A 40% increase in the cost of the combined cycle unit (excluding the oxygen plant and CO<sub>2</sub> compression), per MW of gross output, contributes to the relatively high cost of the natural gas fired oxy-combustion plant.

### 6.7.2 Costs of CO<sub>2</sub> transport and storage

The power plants described above include compression of CO<sub>2</sub> to 11 MPa, for pipeline transport and underground storage. Costs of transporting CO<sub>2</sub> from a power plant to a storage site and the costs of storage depend on local circumstances. If the CO<sub>2</sub> is used for enhanced oil recovery the revenue from additional oil production could in some cases be greater than the total costs of CO<sub>2</sub> capture, transport and storage. For example, at a crude oil price of 50 \$ per barrel and a typical CO<sub>2</sub> storage of 0.33 t/barrel of incremental oil production by miscible injection, the gross oil revenue would be equivalent to 150 \$/t CO<sub>2</sub>, although the net revenues would be lower after subtracting oil field costs, taxes and royalties. However, if CO<sub>2</sub> capture and storage was applied widely most CO<sub>2</sub> would have to be stored in disused hydrocarbon fields or deep saline aquifers, which would generate no revenue. Recent studies indicate that the average costs of CO<sub>2</sub> transport and storage, excluding oil revenues, may be about 4-5 \$/t CO<sub>2</sub> stored in Europe and 12.5 \$/t CO<sub>2</sub>

stored in North America. The main reason for the difference in costs is assumptions made about the injectivity of the storage reservoirs, which affects the well spacing required to inject a given quantity of CO<sub>2</sub>. An illustrative cost of 10 \$/t of CO<sub>2</sub> stored would increase the cost of electricity by about 0.8 c/kWh for the coal-fired plants and about 0.4 c/kWh for the gas-fired plants. The impact is lower for the gas-fired plants because less than half as much CO<sub>2</sub> is stored per kWh of net electricity. A transport and storage cost of 10 \$/t CO<sub>2</sub> would increase the cost of CO<sub>2</sub> avoided by about 13 \$/t CO<sub>2</sub> for the coal-fired plants and 12 \$/t CO<sub>2</sub> for the gas-fired plants. The cost per tonne of CO<sub>2</sub> avoided is greater than the cost per tonne of CO<sub>2</sub> stored, because the quantity of CO<sub>2</sub> stored is greater than the quantity of emissions avoided as a result of the reduction in thermal efficiency caused by CO<sub>2</sub> capture.

## 7 Conclusions and abstract

### 7.1 Abstract

The present study is aimed at initiating a unitary procedure and coherent original analysis concerning the consequences of implementing of each proposal from the EU package on "climate change and energy" towards Romania.

This package is designed to achieve the EU's overall environmental target of a 20% reduction in greenhouse gases and a 20% share of renewable energy in the EU's total energy consumption by 2020. The EU climate-energy package includes:

- Directive 2009/29/EC which improves and extends the greenhouse gas emission allowance trading scheme of the Community;
- Decision no. 406/2009/EC is about the effort of Member States to reduce their greenhouse gas emissions to meet the Community's greenhouse gas emission reduction commitments up to 2020;
- Directive 2009/28/EC is concerning the use of energy from renewable sources and their promotion;
- Directive 2009/31/EC refers to the geological storage of carbon dioxide.

For long term, the attention should be given to carbon capture and storage technologies, which involve the capture, transport and geological storage of CO<sub>2</sub>, applied especially to electricity producers and highly polluting industries.

CO<sub>2</sub> can be captured from large CO<sub>2</sub> emitting sources by means of three main technological options:

- Post-combustion (CO<sub>2</sub> is separated from the flue gas after combustion of the fuel in air);
- Oxy-fuel combustion (CO<sub>2</sub> is practically the only product after combustion in almost pure oxygen and recycled flue gas, instead of in air);
- Pre-combustion (CO<sub>2</sub> is removed from the fuel before combustion).

According to the Romanian National Allocation Plan, for the period 2008-2012, there have been identified eight industrial sectors being covered by the emissions trading scheme:

- Energy (with a total number of installations of 146);
- Refineries (9 installations);
- Production and processing of ferrous metals (15 installations);
- Cement production (7 installations);
- Lime production (7 installations);
- Manufacture of glass including glass fibre (7 installations);
- Manufacture of ceramic products (28 installations);
- Pulp, paper and board production (10 installations).

The main scope of this thesis consists of developing a methodology that predicts the costs for CO<sub>2</sub> rich technologies to be paid. It is based on ten case studies, representative for Romania, Table 7.1.

Table 7.1. Case studies analyzed

<b>Installation No.</b>	<b>ETS type of activity</b>
Installation No. 1 (production of electricity)	Combustion installations with a rated thermal input exceeding 20 MW (except hazardous or municipal waste installations)
Installation No. 2 (production of electricity and heat)	Combustion installations with a rated thermal input exceeding 20 MW (except hazardous or municipal waste installations)
Installation No. 3 (oil refining)	Installations for oil refining
Installation No. 4 (production of ferrous metals)	Installations for the production of pig iron or steel (primary or secondary fusion) including continuous casting, with a capacity exceeding 2.5 t/h
Installation No. 5 (production of cement clinker)	Installations for the production of cement clinker in rotary kilns with a production capacity exceeding 500 t/day
Installation No. 6 (production of lime)	Installations for the production of lime in rotary kilns or in other furnaces with a production capacity exceeding 50 t/day
Installation No. 7 (manufacture of glass and glass fibre)	Installations for the manufacture of glass including glass fibre with a melting capacity exceeding 20 t/d
Installation No. 8 (manufacture of ceramic products)	Installations for the manufacture of ceramic products by firing, in particular roofing tiles, bricks, refractory bricks, tiles, stoneware or porcelain: (i) with a production capacity exceeding 75 t/day; (ii) with a kiln capacity exceeding 4 m <sup>3</sup> and with a setting density per kiln exceeding 300 kg/m <sup>3</sup>
Installation No. 9 (production of paper and board)	Industrial plants for the production of: (i) pulp from timber or other fibrous materials; (ii) for the production of paper and board with a production capacity exceeding 20 t/day
Installation No. 10 (chemical)	Combustion units with a total rated thermal input exceeding 20 MW and a production capacity exceeding 50 t/day

The research was carried out according to the following steps:

- Analysis of the current situation and projected evolution of industrial sectors in Romania;
- Identification of the costs induced by the application of the EU legislative package on the types of industrial activities, by means of an original mathematical model created;
- Cost evolution induced by the legislative package for the period 2013-2020.

Table 7.2 shows the estimation of costs for a representative installation.

Table 7.2. Cost estimation

Installation No.	Formulae
Installation No. 2 (production of electricity and heat)	<p>Cost produced by CO<sub>2</sub> = Cost of production with ETS – Initial cost</p> <p>Cost of production with ETS = Total costs with ETS / Physical production of installation</p> <p>Total costs with ETS = Costs with purchased allowances + Total costs + Other costs caused by ETS (Additional costs with emission allowances trading and monitoring)</p> <p>Costs with purchased allowances = Number of allowances to be purchased + Price of certificate</p>

The investigation carried out has clearly shown that the most affected sectors are those which produce electricity and heat. These sectors emit the largest amount of CO<sub>2</sub> per unit of production. It means they will obviously have to buy the largest quantity of emission allowances.

In parallel, one demonstrated that industrial sectors consuming electrical energy for the production processes are affected by the large quantities of emissions generated into the atmosphere and, indirectly, by the amount of electricity purchased. Thus, production costs will increase by 20-70% compared to 2009, depending on the type of industrial activity.

In terms of application of legislative provisions stipulated by Directive 2009/29/EC, starting from 2013, the mitigation of greenhouse gas emissions becomes a priority for each state. All industrial units will be able to keep their competitiveness on the market through: optimization of industrial processes and improvement of energy efficiency.

## 7.2 General conclusions

The European Union Emissions Trading Scheme is the first international trading system for carbon dioxide emissions in the world and is a cornerstone of the EU's efforts to address the issue of climate change and meet its obligation under the Kyoto Protocol.

This scheme covers more than 10000 energy intensive facilities across the EU's Member States, including power plants, refineries, coke ovens, iron and steel plants, along with cement, glass, lime, ceramics, and pulp and paper installations. Covered entities emit about half of the EU's carbon dioxide emissions.

In 2007, in the EU27 approximately 5 Gt CO<sub>2-eq</sub> were emitted into the atmosphere. This figure marked an overall reduction of 9.3% when compared with 1990. The most important source of greenhouse gas emissions across the EU27 was energy use (about 60% of total emissions).

To help reduce the emissions of greenhouse gases the Council of the European Union adopted in April 2009 the climate-energy legislative package, which includes the following three key targets:

- cut greenhouse gases by at least 20% of their 1990 levels by 2020;
- increase the use of renewables to 20% of total energy production by 2020;
- cut energy consumption by 20% in relation to projected 2020 levels by improving energy efficiency.

The EU-ETS uses a market-based mechanism to stimulate the reduction of GHG emissions in a cost-effective and economically-efficient manner. The scheme operates through the allocation and trade of emissions allowances throughout the European Union.

An overall limit is set by each Member State on the total number of allowances to issue to installations in the scheme, based on the Member States emission reduction targets. The allowances are then distributed by Member States to the installations in the scheme.

The EU-ETS requires all annual emissions reports and monitoring to be verified by an independent accredited verifier. A verifier will check for inconsistencies in monitoring with the approved plan and errors in the emissions report. They will produce a verification opinion statement which must then be sent with the now verified annual emissions report to the regulator by 31 March the following year.

In January 2005, the first phase of the EU-ETS began. A second, phase 2, trading period began in 2008, covering the period of the Kyoto Protocol, with a phase 3 proposed for 2013. Several positives resulting from the phase 1 (learning by doing) exercise assisted the ETS in making the phase 2 process run more smoothly, including: (i) greatly improving emissions data; (ii) encouraging development of the Kyoto Protocol's project-based mechanisms (Clean Development Mechanism and Joint Implementation); and, (iii) influencing corporate behavior to begin pricing in the value of allowances in decision-making, particularly in the electric utility sector.

However, several issues that arose during the first phase were not resolved as the ETS moved into phase 2, including allocation schemes, shutdown credits and new entrant reserves, and others. In addition, the expansion of the EU and the implementation of the directives linking the ETS to the Kyoto Protocol project-based mechanisms created new issues to which phase 2 had to respond. A more comprehensive response to these issues is envisioned for phase 3.

In accordance with the Kyoto Protocol, Romania is committed to reducing its greenhouse gas emissions by 8% compared to the base year of 1989, during the period 2008-2012. Based on the trends of greenhouse gas emissions, there is a great probability for Romania to meet these commitments with the existing policies and measures.

In 2004, according to Romania's National Inventory Report for anthropogenic emissions of direct greenhouse gases and indirect greenhouse gases, the total quantity of GHG emissions was about 155 million tonnes CO<sub>2</sub>-eq. This represents more than 50% below the obligation under the Kyoto Protocol. The largest contributor to the overall GHG emissions is CO<sub>2</sub> (75%), followed by CH<sub>4</sub> and N<sub>2</sub>O.

Energy is the most important sector for total GHG emissions of Romania. The energy sector accounts for almost 70% of the total GHG emissions, followed by



the industrial processes sector (with about 11%). The GHG emissions generated in the energy sector decreased with approximately 40% comparing with the base year, while in the industrial sector decreased with more than 55%. The main reason for this important decrease of GHG emissions is the decline of certain productions and the restructuring of main industrial branches.

### 7.3 Study conclusions

This study has been carried out in order to investigate the impact of various industrial activities on the environment. The work was divided into three main parts:

- Overview of industrial activities;
- Analysis of production costs for each industrial activity;
- Identifying the best measures to lower overall costs, including mitigating greenhouse gas emissions, namely: (i) investigation of technological possibilities to reduce GHGs; (ii) analysis of specific measures to reduce the implementation costs of the legislative package; (iii) presentation of the carbon capture and storage technology.

To identify the specific costs by type of industrial activity there were selected a number of about 40 industrial operators for each industrial activity (ETS and non ETS). They were asked to participate in this study by answering to a questionnaire. Unfortunately, there were received only 13 replies, containing technical and economic data.

The questionnaire sent to operators was divided into the following distinct parts:

- General information;
- Data concerning the costs of production;
- Amount of CO<sub>2</sub> emissions emitted in 2007 and 2008;
- Identification of the costs to apply the emissions trading scheme;
- Measures to reduce the emissions of greenhouse gas in 2007 and 2008, estimating the costs of reducing the emissions of GHG for the period 2009-2020, taking into account the provisions of the new legislative package.

The investigation has been performed under the following assumptions:

- Costs of monitoring, reporting and verification of the CO<sub>2</sub> emissions are considered to remain virtually constant with those from the period 2008-2012, having a very low share of production costs;
- Costs of purchasing and trading of the emission allowances, needed to cover the emissions emitted after 2012, are calculated in the following situations: (i) allowance purchasing price between 15 and 40 € per certificate; (ii) allowance trading price of 0.01 € per certificate;
- Six case studies of the production increase have been analyzed: (i) basic case study, according which the growth of average annual production corresponds to the estimations provided by responses to questionnaires or the trends estimated in NAP, into two allowance price options; (ii) case study with growth zero, according which the average annual production for the period 2008-2012 and for 2013 will not increase compared to 2007 or 2008, due to the current economic and social

conditions, also into two allowance price options; (iii) case study with 10% increase or decrease of the average annual production for the period 2008-2012 compared with 2007, also into two allowance price options;

The following conclusions can be drawn:

- Purchasing and trading costs of allowances for 2013 depend mainly on the number of additional allowances purchased, different allowance prices;
- For the period from 2013 onwards, there will be taken into account the provisions of Directive 2009/29/EC, through which the European Commission expressed its firm commitment to reduce its greenhouse gas emissions by 20% compared with 1990, by 2020: (i) the amount of emission allowances to be issued for 2013 is reduced by the linear reduction factor of 1.74% of the average annual total amount of allowances which were allocated in 2008-2012 through Member States' National Allocation Plans; (ii) the producers of electrical energy will have to pay for these allowances from State's authorities, unlike the current situation, when the allocation of emission allowances is free of charge. Therefore, the cost of these allowances will be reflected in a higher cost of electricity to the final consumer; (iii) industrial sectors will be faced with an increase in cost of electricity and production costs, losing in this way a competitive advantage over similar producers, which have locations in countries outside the European Union. This might lead the European producers to move to other countries, thus affecting the economy of EU as well as the standard of living of EU citizens; (iv) free allocation will be give to the installations with the best performance, proportional to the level of reference of the best available technology. Therefore, the installations which do not meet this criterion will have to pay for the greenhouse gas emission allowances, which will be auctioned; (v) taking into consideration that installations from Romania's industrial sectors and subsectors have relatively low performance, the amount of emission allowances to be purchased will be greater and different for each sector. That is why the calculation has been carried out for values ranging between 5 and 40%. These values are very different for each representative installation and depend on the total number of emission allowances to be allocated in 2013 (lower by 1.74% per year in comparison to the mid-point of the 2008-2012 period), the cost of electricity purchased, the profit and the allowance price.

The impact of the climate-energy legislative package on industrial activities covered by emission trading scheme is:

- Concerning the profit: (i) as industrial production increases, for the same allowance price and the same amount of allowances not allocated, the profit decreases; (ii) as the quantity of purchased allowances increases, for the same allowance price, the profit decreases (i.e., purchasing more allowances will lead to the reduction in profit); (iii) as allowance price increases, for the same amount of purchased allowances and the same production case study, the profit decreases;
- Concerning the selling price: (i) as the amount of purchased allowances increases, for the same allowance price, the selling price of a product

increases; (ii) as the allowance price increases, for the same amount of purchased allowances, the selling price of a product increases as well.

Figure 7.1 shows additional specific costs for base scenario with 20% reduction in allowances and price for one certificate of 15 €. It can be clearly seen that, from 2013, the most affected sectors will be those which produce electricity and heat. These sectors emit the largest quantity of CO<sub>2</sub> and thus will need to buy a significant number of allowances.

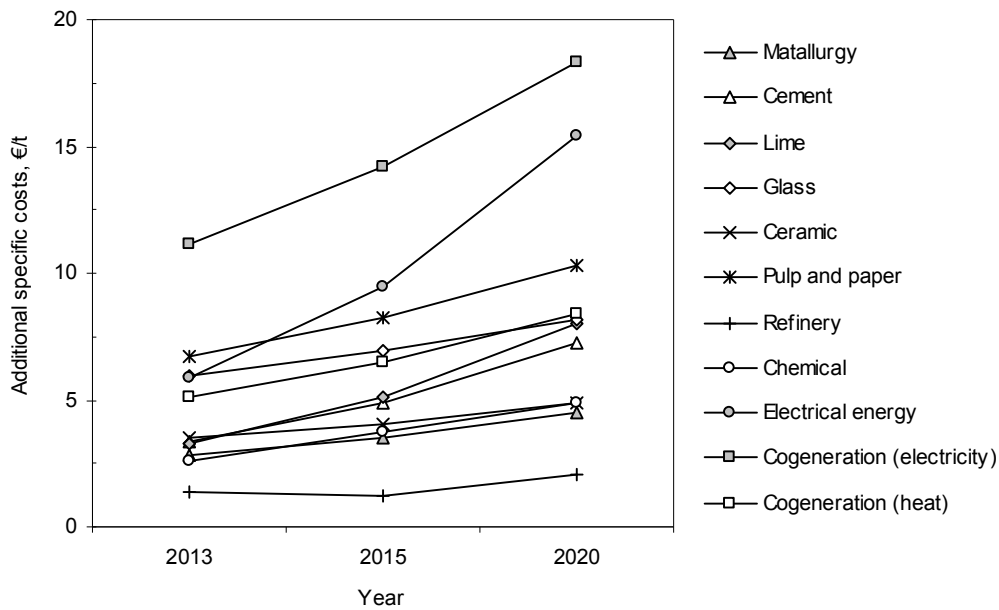

Figure 7.1. Additional specific costs, Base Scenario, 20% reduction, 15 €/certificate

Figure 7.2 shows additional specific costs for base scenario with 20% reduction in allowances and price for one certificate of 40 €. The same behavior as in Figure 7.1 is noted. Energy sector is the most affected one.

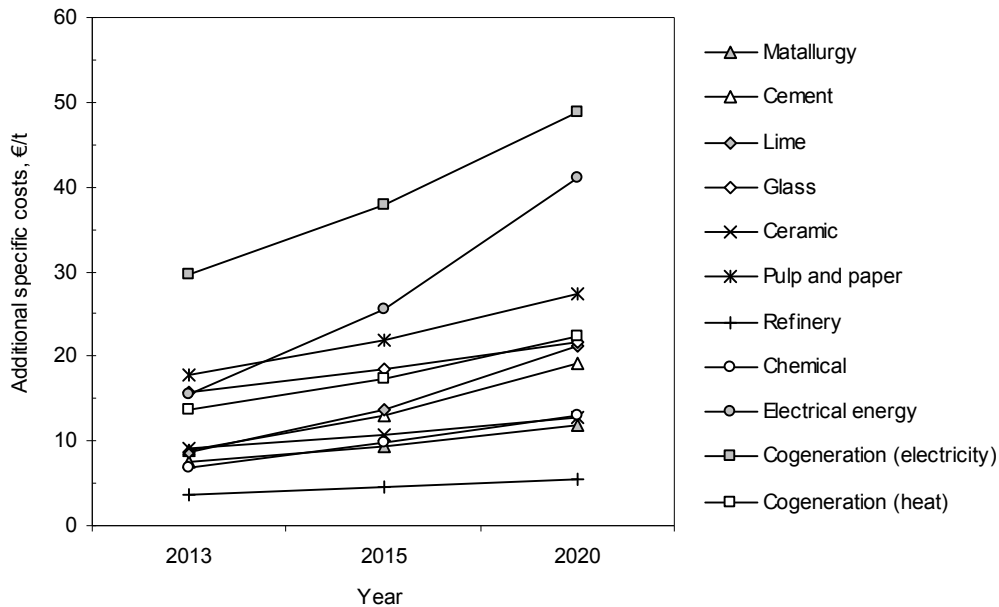

Figure 7.2. Additional specific costs, Base Scenario, 20% reduction, 40 €/certificate

Industrial sectors that consume electrical energy for the production processes are affected by the large quantities of emissions generated into the atmosphere and, indirectly, by the amount of electricity purchased.

All industrial units will be able to keep their competitiveness on the market through: (i) optimization of industrial processes; and (ii) improvement of energy efficiency.

Production costs will increase by 20-70% compared to 2009, depending on the type of industrial activity. Analyses carried out concerning the increase of production costs, due to additional costs caused by the implementation of ETS for different industries, will have to be updated according to the latest achievements and provisions for each industrial sector. Also, it should be taken into account the evolution of the CO<sub>2</sub> price on the carbon market.

In terms of applying the provisions of the legislative package, from 2013 onwards, mitigation of GHG emissions should become a priority for EU operators. They will be able to maintain the competitiveness on the market by:

- Optimization of industrial processes by implementing measures specified in the reference documents on best available techniques (the most important measure is to improve the energy efficiency of production processes);
- Implementation of CCS technologies, which involve the capture, transport and storage of CO<sub>2</sub>, especially should be applied to fossil fuel-fired power plants.

## 7.4 Personal contributions

The contributions are as follows:

- Thorough research of the EU legislative provisions with regard to climate change;
- Identification of highly polluting industries in the Romanian economy, which are affected by the new legislative provisions;
- Development of some models for analyzing the impact of the EU legislation on the economic performance of industrial operators;
- Collection and processing of the economic and technical data;
- Determination of the share of variable elements, as well as their effects, on the profitability and economic competitiveness of the analyzed industries;
- Identification of the most appropriate and immediate corrective measures of economic effects determined by the EU legislative provisions as well as practical modalities for their implementation.

## 7.5 Recommendations

The following recommendations are to be considered:

- The need for realization and implementation of a system that will be designed for evaluation and data collection (operators should report these data);
- The research was developed taking into account the old organizational structure of energy sector with companies based on primary energy sources (thermal, hydro, nuclear);
- The establishment of two national energy companies (namely Electrica and Hidroenergetica), with mixed structures of fuels, will need the development of a new study for optimization of power plants so that the costs of production of electricity to be as low as possible;
- Concerning the management of certificates portfolio, it should be accurately assessed so that the impact of their price to be minimized;
- It imposes that by 2012 the potential of allowances available will not be "wasted" and be used strictly for investment in emission reduction;
- Not application or delay in adopting the recommended measures may have economic consequences, which will be difficult to recover and could lead to the shut down of the industrial unit.

## References

- B1      **Badescu, D.,**  
Tomescu, C.,  
Ionel, I.,  
Padurean, I.,  
Cebrucean, V.      *Implementation of the lime semidry  
desulphurization process in the Romanian  
energy industry – Case study.* Metalurgia  
International, vol. XIV, no. 9, pp. 9-13, 2009
- B2      **Badescu, D.,**  
Dobrin, M.,  
Ionel, I.,  
Padurean, I.,  
Padure, G.      *Contributions regarding the national  
management system for reporting at European  
level of greenhouse gas emissions data  
resulted from the industrial sectors covered by  
EU-ETS Directive.* Metalurgia International, vol.  
XIV, no. 9, pp. 27-32, 2009
- B3      Bailey D.W.,  
Feron P.H.M.      *Post-combustion decarbonisation processes.* Oil  
& Gas Science and Technology – Rev. IFP, vol.  
60, pp. 461-474, 2005
- B4      Barker D.J.,  
Turner S.A.,  
Napier-Moore P.A.,  
Clark M.,  
Davison J.E.      *CO<sub>2</sub> capture in the cement industry.* Energy  
Procedia, vol. 1, pp. 87-94, 2009
- B5      Bohm M.C.,  
Herzog H.J.,  
Parsons J.E.,  
Sekar R.C.      *Capture-ready coal plants – Options,  
technologies and economics.* International  
Journal of Greenhouse Gas Control, vol. 1, pp.  
113-120, 2007
- C1      Calin, L.,  
Jadaneant, M.,  
Lontis, N.      *Gasification of the wood biomass-energy  
source.* Scientific Bulletin of PUT, Transactions  
on Mechanics, tom 52(66), fasc. 7, pp. 231-  
234, 2007
- C2      Capoor K.,  
Ambrosi P.      *State and trends of the carbon market 2009.*  
The World Bank, 2009
- C3      Cardu, M.,  
Ionel, I.,  
Ungureanu, C.      *Ecological aspects concerning the combustion  
of lignite in Romanian thermopower plants.*  
Energy Conversion and Management, vol. 46,  
pp. 1645-1654, 2005

- C4 Cioabla, A.E., Ionel, I., Jadaneant, M., Popescu, F., Savu, A. *State of the art on biogas from biomass residues at the unconventional energies laboratory at Politehnica University of Timisoara*. Scientific Bulletin of PUT, Transactions on Mechanics, tom 52(66), fasc. 7, pp. 235-240, 2007
- C5 Consonni S., Lozza G., Pelliccia G., Rossini S., Saviano F. *Chemical-looping combustion for combined cycles with CO<sub>2</sub> capture*. ASME Journal of Engineering for Gas Turbines and Power, vol. 128, pp. 525-534, 2006
- C6 Constantin, C., Samoila, R., Nihfidov, O., **Badescu, D.**, Necsulescu, A., Enescu, A. *Supporting soft for monitoring and reporting in real time greenhouse gas emissions (GHG)*. Bulletin of ISPE, no. 51, 2008 [in Romanian]
- D1 Dawson, B., Spannagle, M. *The Complete Guide to Climate Change*. Routledge, Taylor & Francis Group, 2009.
- D2 Dones R., Heck T., Hirschberg S. *Greenhouse gas emissions from energy systems, comparison and overview*. Encyclopedia of Energy, vol. 3, pp. 77-95, 2004
- E1 European Commission *Directive 2003/87/EC of the European Parliament and of the Council of 13 October 2003 establishing a scheme for greenhouse gas emission allowance trading within the Community and amending Council Directive 96/61/EC*. Official Journal of the European Union, L 275, pp. 32-46, 2003
- E2 European Commission *Directive 2009/29/EC of the European Parliament and of the Council of 23 April 2009 amending Directive 2003/87/EC so as to improve and extend the greenhouse gas emission allowance trading scheme of the Community*. Official Journal of the European Union, L 140, pp. 63-87, 2009

- E3 European Commission *Directive 2009/31/EC of the European Parliament and of the Council of 23 April 2009 on the geological storage of carbon dioxide and amending Council Directive 85/337/EEC, European Parliament and Council Directives 2000/60/EC, 2001/80/EC, 2004/35/EC, 2006/12/EC, 2008/1/EC and Regulation (EC) No 1013/2006. Official Journal of the European Union, L 140, pp. 114-140, 2009*
- E4 European Commission *Directive 2009/28/EC of the European Parliament and of the Council of 23 April 2009 on the promotion of the use of energy from renewable sources and amending and subsequently repealing Directives 2001/77/EC and 2003/30/EC. Official Journal of the European Union, L 140, pp. 16-62, 2009*
- E5 European Commission *Directive 2004/8/EC of the European Parliament and of the Council of 11 February 2004 on the promotion of cogeneration based on a usual heat demand in the internal energy market and amending Directive 92/42/EEC. Official Journal of the European Union, L 52, pp. 50-60, 2004*
- E6 European Commission *Decision No 406/2009/EC of the European Parliament and of the Council of 23 April 2009 on the effort of Member States to reduce their greenhouse gas emissions to meet the Community's greenhouse gas emission reduction commitments up to 2010. Official Journal of the European Union, L 140, pp. 136-148, 2009*
- E7 European Commission *Commission Decision of 24 December 2009 determining, pursuant to Directive 2003/87/EC of the European Parliament and of the Council, a list of sectors and subsectors which are deemed to be exposed to a significant risk of carbon leakage. Official Journal of the European Union, L 1, pp. 10-18, 2010*
- E8 European Commission *Commission Decision of 9 July 2010 on the Community-wide quantity of allowances to be issued under the EU Emission Trading Scheme for 2013. Official Journal of the European Union, L 175, pp. 36-37, 2010*



- |     |   |   |
|-----|---|---|
| E9  | European Commission   | <i>Reference document on best available techniques for the manufacture of: Large volume inorganic chemicals – ammonia, acids and fertilizers.</i> IPPC/LVIC-AAF, 2007 |
| E10 | European Commission   | <i>Reference document on best available techniques for the manufacture of: Large volume inorganic chemicals – solids and others industry.</i> IPPC/LVIC-S, 2007       |
| E11 | European Commission   | <i>Reference document on best available techniques in the glass manufacturing industry.</i> IPPC/GLS, 2001  |
| E12 | European Commission   | <i>Reference document on best available techniques in the non ferrous metals industries.</i> IPPC/NFM, 2001   |
| E13 | European Commission   | <i>Reference document on best available techniques in the large volume organic chemical industry.</i> IPPC/LVOC, 2003   |
| E14 | European Commission   | <i>Analysis of options to move beyond 20% greenhouse gas emission reductions and assessing the risk of carbon leakage.</i> Communication 265, 2010                    |
| E15 | European Commission   | <i>Green paper – towards a European strategy for the security of energy supply.</i> European Commission, 2001   |
| E16 | European Commission, McKinsey & Company, Ecofys                         | <i>EU ETS Review – Report on International Competitiveness.</i> 2006  |
| E17 | European CCS Demonstration Project Network                              | <a href="http://www.ccsnetwork.eu">www.ccsnetwork.eu</a>  |
| E18 | European Technology Platform for Zero Emission Fossil Fuel Power Plants | <a href="http://www.zeroemissionsplatform.eu">www.zeroemissionsplatform.eu</a>  |
| F1  | Feron P.H.M., Hendriks C.A.   | <i>CO<sub>2</sub> capture process principles and costs.</i> Oil & Gas Science and Technology – Rev. IFP, vol. 60, pp. 451-459, 2005                                   |

- F2      Figueroa J.D.,  
Fout T.,  
Plasynski S.,  
McIlvried H.,  
Srivastava R.D.      *Advances in CO<sub>2</sub> capture technology – The U.S. Department of Energy’s Carbon Sequestration Program*. International Journal of Greenhouse Gas Control, vol. 2, pp. 9-20, 2008
- G1      Gambini M.,  
Vellini M.      *CO<sub>2</sub> emission abatement from fossil fuel power plants by exhaust gas treatment*. ASME Journal of Engineering for Gas Turbines and Power, vol. 125, pp. 365-373, 2003
- G2      Graus W.,  
Worrell E.      *Trend in efficiency and capacity of fossil power generation in the EU*. Energy Policy, vol. 37, pp. 2147-2160, 2009
- G3      Gregoriou, A.,  
Healy, J.V.      *Trading costs for futures in the European Union Emissions Trading Scheme*. University of East Anglia, Working Paper, 2009
- G4      Gronwald, M.,  
Ketterer, J.      *Evaluating emission trading as a policy tool – Evidence from conditional jump models*. CESifo, Working Paper, no. 2682, 2009
- H1      Hektor E.,  
Berntsson T.      *Future CO<sub>2</sub> removal from pulp mills – Process integration consequences*. Energy Conversion and Management, vol. 48, pp. 3025-3033, 2007
- H2      Hektor E.,  
Berntsson T.      *Reduction of greenhouse gases in integrated pulp and paper mills: possibilities for CO<sub>2</sub> capture and storage*. Clean Technologies and Environmental Policy, vol. 11, pp. 59-65, 2009
- H3      Herzog H.,  
Golomb D.      *Carbon capture and storage from fossil fuel use*. Encyclopedia of Energy, vol. 1, pp. 277-287, 2004
- I1      Intergovernmental  
Panel on Climate  
Change      *Carbon Dioxide Capture and Storage*. IPCC Special Report, Metz B., Davidson O., de Coninck H., Loos M. and Meyer L. (eds.), Cambridge University Press, 2005
- I2      Intergovernmental  
Panel on Climate  
Change      *Climate Change 2007: Synthesis Report*. IPCC 4<sup>th</sup> Assessment Report, Pachauri R.K. and Reisinger A. (eds.), IPCC, Geneva, Switzerland
- I3      Intergovernmental  
Panel on Climate  
Change      *2006 IPCC Guidelines for National Greenhouse Gas Inventors*. Eggleston H.S., Buendia L., Miwa K., Ngara T. and Tanabe K. (eds.), Institute for Global Environmental Strategies, Japan, 2006

- 
- |     |   |   |
|-----|---|---|
| I4  | International Energy Agency   | <i>CO<sub>2</sub> emissions from fuel combustion</i> . 2009 Edition. OECD/IEA, 2009   |
| I5  | International Energy Agency   | <i>Key world energy statistics 2009</i> . OECD/IEA, 2009  |
| I6  | International Energy Agency Greenhouse Gas Research and Development Programme | <i>CO<sub>2</sub> capture ready plants</i> . IEA GHG R&D Programme, Technical Study, Report 2007/4, 2007  |
| I7  | International Energy Agency Greenhouse Gas Research and Development Programme | <i>Storing CO<sub>2</sub> underground</i> . IEA GHG R&D Programme, 2007   |
| I8  | International Energy Agency Greenhouse Gas Research and Development Programme | <i>Ocean storage of CO<sub>2</sub></i> . IEA GHG R&D Programme, 2002  |
| I9  | International Energy Agency Greenhouse Gas Research and Development Programme | <i>Geological storage of carbon dioxide. Staying safely underground</i> . IEA GHG R&D Programme, 2008   |
| I10 | Ionel, I.   | <i>Impact on the air quality due to Romanian power plants</i> . VDI Verlag, 2001  |
| I11 | Ionel, I.   | <i>Dispersion of Flue Gases</i> . Politehnica Publishing House, Timisoara, 2000 [in Romanian]   |
| I12 | Ionel, I.   | <i>The role of coal in energy production in Romania</i> . Symposium on New Coal Utilization Technologies, Helsinki, 10-13 May, 1993   |
| I13 | Ionel, I.   | <i>Carbon dioxide reduction by means of suitable pre-drying of moisture fuels</i> . Proceedings of the 1 <sup>st</sup> Mediterranean Combustion Symposium, pp. 498-507, 1999  |
| I14 | Ionel, I., Popescu, F., Lontis, N., Trif-Tordai, G., Russ, W.M.               | <i>Co-combustion of fossil fuel with biofuel in small cogeneration systems, between necessity and achievements</i> . Proceedings of the 11 <sup>th</sup> WSEAS International Conference on Sustainability in Science Engineering, pp. 352-357, 2009 |

- I15 Ionel, I.,  
Ungureanu, C. *Thermoenergetics and Environment*. Tehnica Publishing House, Bucharest, 1996 [in Romanian]
- I16 Ionel, I.,  
Ionel, S. *A new method for measuring the volatile matter content*. ASME COGEN-TURBO, 5<sup>th</sup> International Conference & Exhibition on Gas Turbine in Cogeneration, IGTI vol. 6, pp. 297-303, 1991
- I17 Ionel, I.,  
Hill, J.P. *Retrofitting a Romanian power plant for cogeneration*. ASME COGEN-TURBO, 6<sup>th</sup> International Conference & Exhibition on Gas Turbine in Cogeneration, IGTI vol. 7, pp. 127-134, 1992
- I18 Ionel, I.,  
Stoian, D.,  
Lelea, D.,  
Hill, J.P. *Contribution of a Romanian power plant to the atmospheric transboundary pollution*. ASME COGEN-TURBO, Vienna, 23-25 August, 1995
- I19 Ionel, I.,  
Oprisa-Stanescu, P.D.,  
Muller, H.,  
Leithner, R. *Numerical simulation of the combustion phenomena with application to a Romanian steam boiler*. Advanced Computational Methods in Heat Transfer V, pp. 511-520, 1998
- I20 Ionel, I.,  
Ungureanu, C. *Environmental impact of Romanian power plants*. Proceeding of the International Conference on Efficiency, Costs, Optimization, Simulation and Environmental Aspects of Energy Systems and Processes, vol. 1, pp. 405-413, 1998
- I21 Ionel, I.,  
Popescu, F.,  
**Badescu, D.** *Non-technical barriers versus technical barriers to implement a new renewable technology*. Proceedings of the 3<sup>rd</sup> International Conference on Energy and Development – Environment – Biomedicine, pp. 96-104, 2009
- I22 Ionel, I.,  
Cioabla, A.E.,  
**Badescu, D.** *Experimental study concerning waste agricultural biomass degradation during anaerobic fermentation*. Proceedings of the 4<sup>th</sup> WSEAS International Conference on Energy Planning, Energy Saving, Environmental Education and 4<sup>th</sup> WSEAS International Conference on Renewable Energy Sources, pp. 150-153, 2010

- I23 Islegan, O., Reichelstein, S. *CO<sub>2</sub> regulations and electricity prices: Cost estimates from coal-fired power plants.* Stanford University, Research Paper, no. 2033, 2009
- K1 Kanamura, T. *A classification study of carbon assets into commodities.* J-POWER, Working Paper, 2009
- K2 Kuramochi T., Faaij A., Ramirez A., Turkenburg W. *Prospects for cost-effective post-combustion CO<sub>2</sub> capture from industrial CHPs.* International Journal of Greenhouse Gas Control, vol. 4, pp. 511-524, 2010
- L1 Lozza G., Chiesa P. *Natural gas decarbonisation to reduce CO<sub>2</sub> emission from combined cycles – Part I: Partial oxidation.* ASME Journal of Engineering for Gas Turbines and Power, vol. 124, pp. 82-88, 2002
- L2 Lozza G., Chiesa P. *Natural gas decarbonisation to reduce CO<sub>2</sub> emission from combined cycles – Part II: Steam-methane reforming.* ASME Journal of Engineering for Gas Turbines and Power, vol. 124, pp. 89-95, 2002
- L3 Lucquiaud M., Gibbson J. *Retrofitting CO<sub>2</sub> capture ready fossil plants with post-combustion capture. Part 1: Requirements for supercritical pulverized coal plants using solvent-based flue gas scrubbing.* Proceedings of the Institution of Mechanical Engineers, Part A: Journal of Power and Energy, vol. 223, pp. 213-226, 2009
- L4 Lucquiaud M., Patel P., Chalmers H., Gibbson J. *Retrofitting CO<sub>2</sub> capture ready fossil plants with post-combustion capture. Part 2: Requirements for natural gas combined cycle plants using solvent-based flue gas scrubbing.* Proceedings of the Institution of Mechanical Engineers, Part A: Journal of Power and Energy, vol. 223, pp. 227-238, 2009
- M1 Morgenstern R.D., Aldy J.E., Herrnstadt E.M., Ho M., Pizer W.A. *Competitiveness impacts of carbon dioxide pricing policies on manufacturing.* In: Assessing U.S. Climate Policy Options, Kopp R.J. and Pizer W.A. (eds.), Resources for the Future, Washington, Issue Brief 7, pp. 95-106, 2007
- M2 Mori Y., Masutani S.M., Nihous G.C., Vega L.A., Kinoshita C.M. *Pre-combustion removal of carbon dioxide from natural gas power plants and the transition to hydrogen energy systems.* ASME Journal of Energy Resources Technology, vol. 114, pp. 221-226, 1992

- |    |   |  |
|----|---|--|
| N1 | National Agency for Environmental Protection          | <a href="http://www.anpm.ro">www.anpm.ro</a>   |
| N2 | National Registry of Greenhouse Gas Emissions         | <a href="http://www.rnges.anpm.ro">www.rnges.anpm.ro</a>   |
| O1 | Orth A.,<br>Anastasijevic N.,<br>Eichberger H.        | <i>Low CO<sub>2</sub> emission technologies for iron and steelmaking as well as titania slag production.</i> Minerals Engineering, vol. 20, pp. 854-861, 2007  |
| P1 | Poparad, M.A.,<br>Jadaneant, M.                       | <i>Depolution technologies in the benefit of mankind. Exhaust gas treatment with the help of SCR system.</i> Scientific Bulletin of PUT, Transactions on Mechanics, tom 52(66), fasc. 7, pp. 221-224, 2007 |
| R1 | Reinaud J.  | <i>Industrial competitiveness under the European Union Emissions Trading Scheme.</i> OECD/IEA, Information paper, 2005   |
| R2 | Reinaud J.  | <i>The European refinery industry under the EU Emissions Trading Scheme – Competitiveness, trade flows and investment implications.</i> OECD/IEA, Information paper, 2005                                  |
| R3 | Romanian Government Decision                          | <i>HG no. 780/2006 privind stabilirea schemei de comercializare a certificatelor de emisii de gaze cu efect de sera.</i> Monitorul Oficial, no. 554, 2006  |
| R4 | Romanian Government Decision                          | <i>HG no. 60/2008 privind aprobarea Planului National de Alocare privind certificatele de emisii de gaze cu efect de sera pentru perioadele 2007 si 2008-2012.</i> Monitorul Oficial, no. 126, 2008        |
| R5 | Romanian Ministry of Environment and Forests          | <a href="http://www.mmediu.ro">www.mmediu.ro</a>   |
| R6 | Romanian Ministry of Environment and Water Management | <i>Romanian National Allocation Plan for the periods 2007 and 2008-2012.</i> Romanian Ministry of Environment and Water Management, 2006   |

- R7 Russ, W.M., Schnappinger, M. *Waste related to the food industry: A challenging in material loops.* In: Utilization of By-Products and Treatment of Waste in the Food Industry, V. Oreopoulou and W.M. Russ (eds.), pp. 1-13, 2007
- S1 Schwartz H.G. *Aluminum production and energy.* Encyclopedia of Energy, vol. 1, pp. 81-95, 2004
- S2 Stromberg L., Lindgren G., Jacoby J., Giering R., Anheden M., Burchhardt U., Altmann H., Kluger F., Stamatelopoulos G.N. *Update on Vattenfall's 30 MWth oxyfuel pilot plant in Schwarze Pumpe.* Energy Procedia, vol. 1, pp. 581-589, 2009
- S3 Szabo L., Hidalgo I., Ciscar J.C., Soria A. *CO<sub>2</sub> emission trading within the European Union and Annex B countries: the cement industry case.* Energy Policy, vol. 34, pp. 72-87, 2006
- T1 Tans, P. *Trends in atmospheric carbon dioxide.* NOAA/ESRL, [www.esrl.noaa.gov](http://www.esrl.noaa.gov)
- U1 Ungureanu, C., Panoiu, I., Zubcu, V., Ionel, I. *Fuels, Combustion Facilities and Facilities.* Politehnica Publishing House, Timisoara, 1998 [in Romanian]
- U2 Ungureanu, C., Secreteanu, N., Ionel, I. *Combustible Gases, Properties, Distribution, Combustion.* Politehnica Publishing House, Timisoara, 2003 [in Romanian]
- V1 Vattenfall [www.vattenfall.com](http://www.vattenfall.com)
- W1 Woerdman, E., Couwenberg, O. *Carbon capture and storage in the European Emissions Trading Scheme.* University of Groningen, Working Paper, 2009
- X1 Xu C., Cang D. *A brief overview of low CO<sub>2</sub> emission technologies for iron and steel making.* International Journal of Iron and Steel Research, vol. 17, pp. 1-7, 2010
- Z1 van Zeben, J.A.W. *(De) Centralized law-making in the revised EU ETS.* Amsterdam Center for Law and Economics, Working Paper, no. 2009-09, 2009

## Annex A: Questionnaire sent to operators

The following questionnaire was sent to operators (in Romanian).

Nr. Crt.	Pentru activități de tip ETS
1	<b>Date generale</b> Autorizația privind emisiile de GES ( inclusiv Planul de măsuri privind monitorizarea și raportarea emisiilor de GES și schema de principiu)
2	<b>Date tehnice privind activitatea industrială realizată în anii 2007, 2008:</b> <ul style="list-style-type: none"> <li>- Capacitatea instalată pe tipuri de instalații și per total</li> <li>- Vechimea instalației ( anul PIF, anul ultimei re tehnologizării/ modernizării/ reparații)</li> <li>- Factorul de utilizare a capacității instalate</li> <li>- Volumul producției fizice anuale</li> <li>- Cantitate energie electrică achiziționată din sistem (dacă este cazul)</li> <li>- Structura consumului de combustibil care generează emisii de CO<sub>2</sub> (tipuri, pondere, cantități, costuri)</li> <li>- Structura consumului de materii prime care generează emisii de CO<sub>2</sub> (tip, cantitate, cost)</li> </ul>
3.	<b>Date privind costurile de producție realizate în anii 2007, 2008</b> <ul style="list-style-type: none"> <li>- Costuri de producție, structura costului de producție</li> <li>- Cost energie electrică achiziționată din sistem (% din cost producție), dacă este cazul</li> <li>- Preț de vânzare producție</li> <li>- Profit din exploatare (%)</li> </ul>
4.	<b>Date privind emisiile de CO<sub>2</sub> aferente instalației în anii 2007, 2008</b> <ul style="list-style-type: none"> <li>- Emisii anuale verificate de CO<sub>2</sub> aferente instalației</li> </ul>
5.	<b>Estimări privind producția anuală pentru perioada 2009+2020</b>
6.	<b>Date privind piața de desfacere a produselor, politica companiei/corporației</b> <ul style="list-style-type: none"> <li>- Producția fizică vândută pe piața internă (% din producția anuală)</li> <li>- Producția vândută pe piața externă (% din producția anuală) specificându-se țările și cantitățile(%), dacă este cazul</li> </ul>
7	<b>Costuri de aplicare a cerințelor ETS</b> <ul style="list-style-type: none"> <li>- Solicitarea/ revizuirea autorizației privind emisiile de GES               <ul style="list-style-type: none"> <li>• Tarife obținere/ revizuire autorizație</li> </ul> </li> <li>- Operarea contului la Registrul Național               <ul style="list-style-type: none"> <li>• Tarife operare cont</li> </ul> </li> <li>- Monitorizarea și raportarea emisiilor de gaze cu efect de seră (CO<sub>2</sub>)               <ul style="list-style-type: none"> <li>• Preț analize efectuate cu laborator acreditat ISO 17025:2005, sau laborator acreditat ISO 9001:2000 cu validarea fiecărei metode analitice de către un laborator ISO:17025</li> <li>• Număr analize pe an pentru fiecare tip de combustibil / materie primă</li> </ul> </li> <li>- Servicii de consultanță prestate de terți pentru întocmirea raportului anual</li> <li>- Verificarea Raportului de monitorizare privind emisiile de GES, de către un organism de verificare acreditat</li> </ul> Cheltuieli suplimentare cu personalul – sesiuni de instruire ETS
8.	<b>Măsuri de reducere a emisiilor de GES implementate în 2008, și costurile acestora</b>
9.	<b>Măsuri de reducere a emisiilor de GES și estimarea costurilor acestora în perioada 2013+2020 ținând cont de prevederile noului pachet legislativ</b>



Answer from an operator (it contains technical and economic data).

Nr crt	Pe nru activitati de tip ETS	Anexa 1																								
1	<p>Autorizatia de emisii de gaze cu efect de sera nr. 5/25.01.2007            Autorizatia de emisii de gaze cu efect de sera nr. 16/20.03.2008            Planul de masuri privind monitorizarea si raportarea emisiilor de gaze cu efect de sera nr. 7500/27.11.2006            Planul de masuri privind monitorizarea si raportarea emisiilor de gaze cu efect de sera nr 15977/14.12.2007</p>																									
2	<p>Date tehnice privind activitatea industrială realizată în anii 2007,2008:</p> <ul style="list-style-type: none"> <li>• Capacitate instalată pe tipuri de instalații și per total :</li> </ul> <p>IMA 1            Cazan abur energetic 1035 t/h Nr.3 (878MWt)- pus în funcțiune în anul 1976 – modernizat în 2006 ✓            Putere electrică instalată : 330 MW            Cazan abur energetic 1035 t/h Nr.4 (878MWt)-pus în funcțiune în anul 1977- modernizat în 2001 ✓            Putere electrică instalată : 330 MW</p> <p>IMA 2            Cazan abur energetic 1035 t/h Nr.5 (878MWt)- pus în funcțiune în anul 1977- modernizat în 2000 ✓            Putere electrică instalată : 330 MW            Cazan abur energetic 1035 t/h Nr.6 (878MWt)-pus în funcțiune în anul 1979 – modernizare în curs ✓            Putere electrică instalată : 330 MW</p> <p>TOTAL :Putere electrică instalată : 1320 MW ; ✓            Putere electrică instalată în exploatare: - Anul 2007 - 990MW ✓            - Anul 2008 - 990 MW</p> <ul style="list-style-type: none"> <li>• Factorul de utilizare a capacității instalate : (Putere medie realizată /Putere instalată =%)            Anul 2007 : - 60,12 %            Anul 2008 : - 70,25 %</li> <li>• Volumul producției fizice anuale :            2007 - Energie produsă : 5.897.182,00 MWh            - Energie livrată : 5.486.920,00 MWh             2008 - Energie produsă : 5.937.029,00 MWh            - Energie livrată : 5.544.031,00MWh</li> <li>• Cantitate energie electrică achiziționată din sistem :            Anul 2007: - 84.060,50 MWh            Anul 2008: - 70.779,40 MWh</li> <li>• Structura consumului de combustibil care generează emisii de CO2 :</li> </ul> <table border="1"> <thead> <tr> <th>Anul 2007</th> <th>Carbune ( tone)</th> <th>Gaze naturale (Nm<sup>3</sup>)</th> <th>Pacura ( tone)</th> </tr> </thead> <tbody> <tr> <td>Consum combustibil</td> <td>7.754.415,00</td> <td>35.443.877,00</td> <td>1.953,78</td> </tr> <tr> <td>Pondere în consum (%)</td> <td>97,77</td> <td>2,10</td> <td>0,13</td> </tr> </tbody> </table> <p>Structura consumului de materii prime care generează emisii de CO2: - nu este cazul</p> <table border="1"> <thead> <tr> <th>Anul 2008</th> <th>Carbune ( tone)</th> <th>Gaze naturale (Nm<sup>3</sup>)</th> <th>Pacura ( tone)</th> </tr> </thead> <tbody> <tr> <td>Consum combustibil</td> <td>7.529.358,00</td> <td>24.834.980,00</td> <td>1.004,32</td> </tr> <tr> <td>Pondere în consum (%)</td> <td>98,43</td> <td>1,51</td> <td>0,06</td> </tr> </tbody> </table> <p>Structura consumului de materii prime care generează emisii de CO2: - nu este cazul            - până în momentul actual nu a fost pusă în funcțiune nici o instalație de desulfurare umedă a gazelor de ardere</p>	Anul 2007	Carbune ( tone)	Gaze naturale (Nm <sup>3</sup> )	Pacura ( tone)	Consum combustibil	7.754.415,00	35.443.877,00	1.953,78	Pondere în consum (%)	97,77	2,10	0,13	Anul 2008	Carbune ( tone)	Gaze naturale (Nm <sup>3</sup> )	Pacura ( tone)	Consum combustibil	7.529.358,00	24.834.980,00	1.004,32	Pondere în consum (%)	98,43	1,51	0,06	
Anul 2007	Carbune ( tone)	Gaze naturale (Nm <sup>3</sup> )	Pacura ( tone)																							
Consum combustibil	7.754.415,00	35.443.877,00	1.953,78																							
Pondere în consum (%)	97,77	2,10	0,13																							
Anul 2008	Carbune ( tone)	Gaze naturale (Nm <sup>3</sup> )	Pacura ( tone)																							
Consum combustibil	7.529.358,00	24.834.980,00	1.004,32																							
Pondere în consum (%)	98,43	1,51	0,06																							

3		Date privind costurile de productie realizate in anii 2007,2008		Anul 2007	Anul 2008								
Nr. crt.	Indicator			2007	2008								
I	Costuri totale, din care	mii lei		654.697	793350								
1	Combustibil tehnologic	mii lei		437.225	475908								
2	Energie electrica din sistem	mii lei		10.588	13.715								
3	Apa tehnologica	mii lei		10.604	10.831								
4	Alte cheltuieli materiale	mii lei		2.512	3.525								
5	Amortizare	mii lei		26.368	28.592								
6	Cheltuieli de mentenanta	mii lei		98.923	162.705								
7	Cheltuieli privind personalul din care:			81.250	69.882								
	- salarii	mii lei		34.610	46.725								
	- alte cheltuieli cu personalul	mii lei		5.733	8.954								
	- contributi si obligatii aferente	mii lei		10.907	14.203								
8	Alte cheltuieli exploatare	mii lei		17.227	28.192								
II	Cost energie electrica achizitionata din sistem	mii lei		10.588	13.715								
III	Pondere energie electrica in cost productie	%		1.62	1.73								
IV	Pret mediu de vanzare energie electrica	Lei /MWh		134.48	156.72								
V	Profit brut din exploatare	mii lei		89.307	14.009								
4	Date privind emisiile de CO <sub>2</sub> aferente instalatiei in anul 2007, 2008												
	• Emisii anuale verificate de CO <sub>2</sub> aferente instalatiei:												
	-Anul 2007 - 6.102.822 t CO <sub>2</sub>												
	-Anul 2008 - 5.853.872 t CO <sub>2</sub>												
5	Estimari privind productia anuala pentru perioada 2009- 2020												
	Anul	2009	2010	2011	2012	2013	2014	2015	2016	2017	2018	2019	2020
	Energie produsa	6078688	6073000	6100000	6000000	6000000	6000000	6100000	6000000	6100000	6100000	6000000	6000000
	Energie livrata	5629967	5500000	5642500	5550000	5550000	5550000	5642500	5550000	5642500	5642500	5550000	5550000
6	Date privind piata de desfacere a produselor, politica companiei/corporatiei												
	• Productia fizica vanduta pe piata internă (% din productia anuala):												
	Anul 2007 - 5.486.920,00 MWh - 93,04 %												
	Anul 2008 - 5.544.031,00 MWh - 93,38 %												
	• Productia vanduta pe piata externa (% din productia anuala):												
	- intreaga cantitate de energie electrica este livrata numai pe piata internă.												
7	Costuri de aplicare a cerintelor ETS												
	Solicitarea /revizuirea autorizatiei privind emisiile de GES												
	• Tarife obtinere /revizuire autorizatie:												
	Anul 2007: - 150 lei - Evaluare preliminara emisii anuale totale - parcurgerea procedurilor privind autorizatia GES												
	- 300 lei - Analiza documente emisii anuale totale - solicitare autorizare privind emisiile de GES												

	<p>- 600 lei -- Aprobarea Planului de masuri privind monitorizarea si raportarea emisiilor de gaze cu efect de sera</p> <p>Anul 2008 : - 150 lei – Evaluare preliminara emisii anuale totale – parcurgerea procedurilor privind autorizatia GES</p> <p>- 300 lei – Analiza documente emisii anuale totale – solicitare autorizare privind emisiile de GES</p> <p>- 300 lei – Analiza Plan de masuri privind monitorizarea si raportarea emisiilor de gaze cu efect de sera</p> <p>- 600 lei – Aprobarea Planului de masuri privind monitorizarea si raportarea emisiilor de gaze cu efect de sera</p> <p>Operarea contului la Registrul National</p> <p>• Tarife operare cont :  Anul 2007 :- arif deschidere cont 711,36 lei ✓ → 0,213 mil Euro  - arif administrare cont - 12.118,61 lei ✓ → 3,63 mil Euro  Anul 2008: - tarif administrare cont - 12.815,60 lei ( la un curs de 4,29 lei/ Euro) - 3482 E (3,68 lei)</p> <p>Monitorizarea si raportarea emisiilor de gaze cu efect de sera (CO<sub>2</sub>)</p> <p>• Pref analize efectuate cu laborator acreditat ISO 17025 , sau laborator acreditat ISO 9001:2000 cu valdarea fiecarei metod : analitice de catre un laborator ISO: 17025 :  Anul 2007 – 82.824,00 lei → 19877 Euro  Anul 2008 – 85.351,56 lei → 23.193 Euro → 23,193 mil Euro</p> <p>• Numar analize pe an pentru fiecare pe an pentru fiecare /materie prima  Anul 2007 :  Combustibil fosil -carbune -lunar /pe probe reprezentative /furnizor – 12*4= 48 analize ( PCN, FE, FO)  Combustibil fosil gazos -gaze naturale : - lunar  Combustibil fosil lichid - pacura - trimestrial  Anul 2008  Combustibil fosil solid - carbune : lunar /pe probe reprezentative /furnizor – 12*4= 48 analize ( FE, FO)  PCN – s-au efectuat analize zilnice in laboratorul propriu pe fiecare furnizor  Combustibil fosil gazos – gaze naturale :- lunar  Combustibil fosil lichid- pacura : - trimestrial</p> <p>• Servicii de consultanta prestate de terti pentru intocmirea raportului anual:  - nu este cazul.</p> <p>• Verificarea Raportului de monitorizare privind emisiile de GES , de catre un organism de verificare acreditat:  Anul 2007 :- 39.800,51 lei ✓ → 11,900 ( :1000) → 11,9 mil Euro  Anul 2008:- 29.746,19 lei ✓ → 8,08 ( :1000) → 8,08 mil Euro</p> <p>- Cheltuieli suplimentare cu personalul – sesiuni de instruire ETS - ?</p>
8	Masuri de reducere a emisiilor de GES implementate in 2008 si costurile acestora : - nu au fost posibile
9	Masuri de reducere a emisiilor de GES si estimarea costurilor acestora in perioada 2013-2020 tinand cont de prevederile noului pachet legislativ : - vor fi analizate

## Annex B: CCS Projects

The following Carbon Capture and Storage Projects have been approved [E17, E18].

Country	Project name	Applicant	Maximum Union contribution, million €
Germany	Jänschwalde	Vattenfall Europe Generation	180
United Kingdom	Hatfield	Powerfuel Power Limited	180
Italy	PortoTolle	Enel Ingegneria e prod.	100
The Netherlands	Rotterdam	Maasvlakte CCS Pjt CV	180
Poland	Bełchatów	PGE Elektrownia Bełchatow	180
Spain	Compostilla	ENDESA Generacion sa	180
<b>Total</b>			<b>1000</b>

Description of projects:

- Germany (Jänschwalde) – Oxy-fuel and post-combustion CO<sub>2</sub> capture technology will be demonstrated at the existing lignite power station in Jänschwalde. The CO<sub>2</sub> emissions capture rate for both the oxy-fuel and the post-combustion process is expected to be in excess of 90%. There will be produced approximately 2.7 million tonnes of liquified CO<sub>2</sub> per year;
- United Kingdom (Hatfield) – This project aims to demonstrate the innovative integrated gasification combined cycle technology on a new 900 MW power plant in Hatfield. The CO<sub>2</sub> emissions capture rate will be almost 91%;
- Italy (Porto Tolle) – The concept of post-combustion capture will be demonstrated on a 250 MW coal and biomass co-firing (<5% of thermal input) power unit, being a part of a new 660 MW coal power plant in Porto Tolle. The rate of CO<sub>2</sub> capture is expected to be over 90%. It is estimated that one million tonnes of CO<sub>2</sub> will be stored per year;
- The Netherlands (Rotterdam) – Approximately four tonnes of CO<sub>2</sub> per day will be captured from flue gas generated by a 250 MW coal-fired power plant. About 1.1 million tonnes of CO<sub>2</sub> will be stored per year;
- Poland (Bełchatów) – Full CCS chain will be demonstrated on a new 250 MW supercritical unit that is part of the existing coal-fired power plant located in Bełchatów. The chosen technology is post-combustion capture. The CO<sub>2</sub> emissions capture rate will be in excess of 80%. More than one million tonnes of CO<sub>2</sub> will be stored per year;
- Spain (Compostilla) – Oxy-fuel technology will be tested on a new 30 MW coal-fired pilot plant and then will be scaled to a demonstration plant of about 323 MW. The CO<sub>2</sub> emissions capture rate is expected to be 91%. Five million tonnes of CO<sub>2</sub> will be stored during the first five years of operation.

## **Rezumatul tezei de doctorat**

Cercetări privind impactul pachetului de Directive UE referitor  
la schimbările climatice și energetice asupra sectorului  
industrial din România

ec. Dorel Cicirone BĂDESCU

Conducători științifici:

Prof.dr.ing. habil Ioana IONEL  
Universitatea "Politehnica" din Timișoara

Prof.dr.ing. habil Winfried RUSS  
Universitatea Tehnică din München

## Introducere

Necesitatea respectării de către România a legislației în materie de mediu a Uniunii Europene impune adaptarea din mers atât a legislației naționale cât și a modului de calcul a influenței acestora în rezultatele economice ai operatorilor industriali.

Cercetarea de față a căutat să inițieze o procedura unitară, coerentă în privința urmărilor implementării fiecărei propuneri din pachetul EU "schimbări climatice și energie".

Cercetarea a fost efectuată etapizat urmărind:

- Analiza situației actuale și a evoluției prognozate a sectoarelor industriale din România;
- Identificarea costurilor induse de aplicarea pachetului legislativ EU pe tipuri de activități industriale, crearea unui model matematic original necesar efectuării cercetării;
- Tendințele de evoluție a costurilor induse de pachetul legislativ pentru perioada 2013-2020.

Din analizele efectuate rezultă că cele mai afectate sectoare sunt cele producătoare de energie electrică și termică, sectoare care emit cea mai mare cantitate de CO<sub>2</sub> pe unitatea de produs și care în mod evident vor cumpăra și cea mai mare cantitate de certificate.

Sectoarele industriale care consumă energie electrică în procesele de producție sunt afectate atât de emisiile proprii cât și indirect din energia electrică achiziționată. Rezultă ca imperios necesară îmbunătățirea eficienței energetice în procesele tehnologice, inclusiv prin utilizarea resurselor recuperabile.

Cheltuielile de producție vor crește diferențiat pe ramuri industriale cu 20 până la 70% față de 2009.

În condițiile aplicării începând cu 2013 a prevederilor legislative prevăzute în Directiva 2009/29/CE, reducerea emisiilor de gaze cu efect de seră devine o prioritate.

## Scopul

Identificarea punctuală a efectelor aplicării prevederilor pachetului legislativ al UE "schimbări climatice și energie" asupra activităților industriale din punct de vedere al problematicilor de mediu, costurilor asociate și efectelor economice.

Cercetarea a fost efectuată pe 10 studii de caz relevante pentru sectorul industrial din România.

## Obiectivul

Obiectivul general al cercetării constă în generarea unui model de calcul, respectiv al unui instrument de analiză comparativă, al impactului generat de activitățile industriale asupra mediului și a posibilităților de diminuare ale acestuia, în contextul actual al angajamentului global de reducere a emisiilor de gaze cu efect de seră.

Acest model, posibil a fi extins la nivel național va da posibilitatea stabilirii unei strategii coerente privind evitarea efectelor induse de aplicarea pachetului legislativ.

## **Pachetul legislativ UE "schimbări climatice și energie"**

Acest pachet legislativ cuprinde:

- Directiva 2009/29/CE de modificare a Directivei 2003/87/CE în vederea îmbunătățirii și extinderii schemei de comercializare a certificatelor de emisii de gaze cu efect de seră;
- Decizia 406/2009/CE privind efortul statelor membre de a reduce emisiile de GES, astfel încât să se respecte angajamentele Comunității de reducere a emisiilor de GES până în anul 2020;
- Directiva 2009/28/CE privind promovarea utilizării surselor regenerabile de energie, de modificare și ulterior de abrogare a Directivelor 2001/77/CE și 2003/30/CE;
- Directiva 2009/31/CE privind stocarea geologică a dioxidului de carbon și de modificare a Directivei 85/337/CEE a Consiliului, precum și a Directivelor 2000/60/CE, 2001/80/CE, 2004/35/CE, 2006/12/CE, 2008/1/CE și a Regulamentului no. 1013/2006 ale Parlamentului European și ale Consiliului;
- Comunicarea Comisiei Europene 2008/C 82/01 "orientări comunitare privind ajutorul de stat pentru protecția mediului".

## **Metoda de lucru**

Cercetarea a fost efectuată pe etape, după cum urmează:

- Etapa I: Analiza situației actuale și a evoluției prognozate pentru sectoarele industriale care intră sub incidența pachetului legislativ UE "schimbări climatice și energie";
- Etapa II: Identificarea costurilor pe tipuri de activități industriale, ca urmare a implementării fiecărei propuneri din pachetul "schimbări climatice și energie", precum și identificarea celor mai bune măsuri de reducere a costurilor de implementare generate, inclusiv pentru reducerea de gaze cu efect de seră;
- Etapa III: Identificarea tendințelor de evoluție a costurilor induse de ETS pentru perioada 2013-2020.

### ***Etapa I***

Au fost analizate cerințele cuprinse în fiecare propunere din pachetul legislativ, cu sublinierea acelor care afectează sectoarele industriale din România.

A fost analizată situația actuală a acestora din punct de vedere al producțiilor industriale și al emisiilor de gaze cu efect de seră.

**Etapa II**

A fost realizată o prezentare generală a activităților industriale care intră sub incidența pachetului legislativ după 2013, pe sectoare de activitate.

S-a realizat o analiză a structurii costurilor de producție pentru fiecare activitate industrială, structura care depinde atât de procesul tehnologic cât și de combustibilii, materia primă, cantitatea de energie electrice utilizată pentru realizarea producției specifice instalației.

Crearea modelului matematic original necesar efectuării cercetării, conceput pentru specificul ramurilor industriale din România.

În Tabelul R1 sunt prezentate instalațiile reprezentative.

Tabelul R1. Studii de caz reprezentative

<b>Studiu de caz</b>	<b>Tipul de activitate ETS</b>	<b>Producție</b>
Instalația no. 1	Instalații de ardere cu o putere termică nominală mai mare de 20 MW (cu excepția instalațiilor pentru deșeuri periculoase și municipale)	Energie electrică
Instalația no. 2	Instalații de ardere cu o putere termică nominală mai mare de 20 MW (cu excepția instalațiilor pentru deșeuri periculoase și municipale)	Energie electrică și termică
Instalația no. 3	Instalații pentru rafinarea țițeiului	Produce obținute prin prelucrarea țițeiului
Instalația no. 4	Instalații pentru producerea fontei sau a oțelului (topire primară ori secundară), inclusiv instalații pentru turnarea continuă, cu o capacitate de producție mai mare de 2.5 tone/oră	Producția de metale feroase sub forme primare
Instalația no. 5	Instalații pentru producerea clincherului de ciment cuptoare rotative cu o capacitate de producție mai mare de 500 tone/zi	Fabricare clincher de ciment
Instalația no. 6	Instalații pentru producerea varului în cuptoare rotative cu o capacitate de producție mai mare de 50 tone/zi, sau în alte tipuri de cuptoare ne-rotative cu o capacitate de producție mai mare de 50 tone/zi	Fabricare var bulgări și var măcinat
Instalația no. 7	Instalații pentru fabricarea sticlei, inclusiv a fibrei de sticlă, cu o capacitate de topire mai mare de 20 tone/zi	Fabricare articole din sticlă și fibră de sticlă
Instalația no. 8	Instalații pentru fabricarea produselor ceramice prin ardere, în special a țiglelor, cărămidilor, cărămidilor refractare, dalelor, plăcilor de gresie sau de faianță: (i) cu o capacitate de producție mai mare de 75 tone/zi; și/sau (ii) cu o capacitate a cuptorului mai mare de 4 m <sup>3</sup> și cu o densitate stabilită pentru fiecare cuptor mai mare de 300 kg/m <sup>3</sup>	Fabricare produse ceramice



Tabelul R1 (continuare)

Instalația no. 9	Instalații industriale pentru producerea de: (i) celuloză din lemn sau din alte materiale fibroase; (ii) hârtie și carton, având o capacitate de producție mai mare de 20 tone/zi	Produse din hârtie și carton
Instalația no. 10	Instalații de ardere cu o putere termică nominală mai mare de 20 MW, cu o capacitate de producție mai mare de 50 tone/zi	Chimie

### Etapa III

S-a analizat piața carbonului-evoluția prețului certificatelor (prognoza 2013). De asemenea, s-a analizat evoluția costurilor de implementare a pachetului legislativ și influența acestora asupra cheltuielilor specifice pe tona de produs.

### Modelul matematic

Calculul consumului estimat de combustibil, pe tip de combustibil pentru fiecare an.

$$B_{av\ fuel\ X} = \Sigma B_X$$

unde:

- $B_{av\ fuel\ X}$  – media consumului de combustibil pentru combustibilul X (păcură, gaz natural sau lignit);  
 $B_X$  – consumul anual de combustibil pe tip.

Calculul emisiilor de CO<sub>2</sub> ca medie pentru patru ani luând în considerare perioada 2009-2012:

$$CEco\ (t\ CO_2/an) = \Sigma (consum\ de\ combustibil\ X\ (TJ/an) \times factorul\ de\ emisie\ carbon\ (t\ C/TJ)) \times factorul\ de\ oxidare\ depinzând\ de\ tipul\ de\ combustibil \times 44/12$$

unde:

- $CEco$  – emisia de carbon provenită din operare.

Calculul emisiilor de CO<sub>2</sub> echivalent din emisiile de N<sub>2</sub>O ca medie pentru patru ani luând în considerare perioada 2009-2012:

$$CeN_2OEco\ (t\ CO_{2-eq}/an) = \Sigma (consum\ de\ combustibil\ X\ (TJ/an) \times N_2O\ factor\ de\ emisie\ (t\ N_2O/TJ)) \times GWP$$

unde:

- $CeN_2OEco$  – CO<sub>2</sub> echivalent emisii de N<sub>2</sub>O din operare;  
 $GWP$  – potențialul de încălzire globală.

Calculul emisiilor de CO<sub>2</sub> echivalent din emisiile de CH<sub>4</sub> provenite din operare ca medie pentru patru ani luând în considerare perioada 2009-2012:

$$CeCH_4Eco \text{ (t CO}_2\text{-eq/an)} = \Sigma (\text{consum de combustibil X (TJ/an)} \times CH_4 \text{ factor de emisie (t CH}_4\text{/TJ)}) \times GWP$$

unde:

$CeCH_4Eco$  – CO<sub>2</sub> echivalent emisii de CH<sub>4</sub> din operare.

Procedura de calcul a costurilor este redată în Tabelul R2.

Tabelul R2. Formule de calcul a costurilor

Studiu de caz	Tipul de activitate ETS	Formule de calcul
Instalația no. 2 (producere de energie electrică și termică)	Instalații de ardere cu o putere termică nominală mai mare de 20 MW (cu excepția instalațiilor pentru deșeuri periculoase și municipale)	<p>Costul produs de CO<sub>2</sub> = Cost producere cu ETS – Cost inițial*</p> <p>Cost producere cu ETS = Cheltuieli totale cu ETS / Producția fizică instalație</p> <p>Cheltuieli totale cu ETS = Cheltuieli achiziție certificate + Cheltuieli totale + Alte cheltuieli determinate de ETS (Cheltuieli suplimentare de tranzacționare și monitorizare certificate)</p> <p>Cheltuieli achiziție certificate = Numărul de certificate de cumpărat × Prețul certificatului**</p>

\*la un moment dat

\*\*prețul pe piață al certificatului la un anumit moment

## Scenarii analizate

Analizele pentru perioada 2013-2020 au fost efectuate pentru următoarele scenarii și variante de evoluție:

- Două scenarii de evoluție a ponderii sectoarelor industriale în produsul intern brut:
  - scenariu de bază care ține seama de realizările anului 2009, precum și de posibilitățile de relansare a economiei românești după perioada de criză;
  - scenariu mărit, care implică o relansare economică mai rapidă după perioada de criză estimându-se o creștere cu 10% a ponderii în PIB a ramurilor industriale față de scenariul de bază;
- Din punct de vedere al creșterii producției nete de energie electrice pe total SEN s-au avut în vedere următoarele variante:
  - varianta de referință care ține cont de realizările anului 2009 și de o relansare moderată a economiei după criză în corelare cu noile evoluții economice din țară și pe plan mondial;
  - varianta pesimistă are în vedere o reluare mai lentă a economiei;

- varianta optimistă care indică o reluare economică mai rapidă, respectiv ritmuri mai mari de creștere a producției de energie electrică, față de varianta de bază.

## Concluzii

### **Concluzii privind rezultatele cercetării**

- Cheltuielile de producție vor crește datorită achiziției certificatelor de CO<sub>2</sub> cu valori cuprinse între 20% și 70%;
- Creșterea eficienței proceselor tehnologice va diminua efectele produse de această creștere, dar, pe de altă parte reducerea plafonului alocat va duce la creșterea cheltuielilor pe produs;
- Achiziția de energie electrică duce de asemenea la creșterea cheltuielilor pe produs datorită faptului că producătorii de energie electrică achiziționând integral certificate de CO<sub>2</sub> (în cazul nealocării tranzitorii) au cheltuielile de producție mărite;
- Produsele care înglobează multă energie și au valoarea adăugată mică, vor fi cele care vor avea cele mai mari creșteri ale costurilor de achiziție a certificatelor de CO<sub>2</sub>;
- Pentru limitarea creșterii cheltuielilor pe produs vor trebui luate măsuri din ce în ce mai ample de creștere a eficienței precum și de reducere, captare/stocare a emisiei de CO<sub>2</sub>;
- În condițiile aplicării începând cu 2013 a prevederilor legislative prevăzute de Directiva 2009/29/CE, reducerea emisiilor de GES devine o prioritate, iar prin aplicarea EU ETS unitățile industriale pot să-și mențină competitivitatea pe piață prin: (i) optimizarea funcționării instalațiilor prin implementarea măsurilor specificate de Documentele de Referință asupra Celor Mai Bune Tehnici Disponibile specifice activităților industriale, din care o pondere importantă o are îmbunătățirea eficienței energetice a proceselor de producție; (ii) pe termen lung, implementarea tehnologiilor CCS, care presupun captarea, transportul și stocarea geologică a CO<sub>2</sub> aplicabilă în special în cazul producătorilor de energie electrică și a industriilor mari poluatoare;
- Din analizele efectuate asupra sectoarelor prezentate rezultă că cele mai afectate sectoare sunt cele producătoare de energie electrică și termică, sectoare care emit și cumpără cea mai mare cantitate de CO<sub>2</sub> pe unitatea de produs;
- Sectoarele care consumă energie electrică în procesele de producție sunt afectate atât de emisiile lor proprii rezultate din procesele de producție, cât și indirect din energia electrică achiziționată;
- Cu cât procesele sunt mai energointensive influența emisiilor rezultate din energia electrică achiziționată este mai mare;
- Rezultă importanța îmbunătățirii eficienței energetice în procesele tehnologice inclusiv prin utilizarea resurselor energetice recuperabile rezultate din procesele de producție;
- Analizele efectuate privind creșterea cheltuielilor de producție datorită cheltuielilor suplimentare privind EU ETS pentru diferite ramuri industriale vor trebui să fie reactualizate în funcție de ultimele realizări și

prevederi pentru fiecare sector industrial in parte precum si funcție de evoluția prețului CO<sub>2</sub> pe piața carbonului;

- Prin aplicarea pachetului legislativ, producătorii de energie electrică sunt dezavantajați prin nealocarea de certificate gratuite începând din anul 2013;
- Producători de energie electrica ar putea obține până în 2020 alocări tranzitorii, cu condiția ca România să adopte un Plan de Acțiune în care să includă lucrări de modernizări și/sau re tehnologizări;
- Pe termen lung elementul cheie al UE de atingere a țintelor de reducere a emisiilor de GES în 2020 este promovarea pe scară largă a dezvoltării tehnologiilor CCS, susținută cu fonduri de CE, prin intermediul unui program demonstrativ de construire până în 2015 a 12 proiecte de captare și stocare a dioxidului de carbon.

### ***Contribuții personale***

- Cercetarea aprofundată a prevederilor legislative ale UE cu referire la schimbările climatice;
- Identificarea sectoarelor industriale mari poluatoare din economia românească ce sunt afectate de noile prevederi legislative;
- Crearea unor modele de analiză a impactului legislației UE asupra performanțelor economice ale operatorilor industriali;
- Obținerea și prelucrarea informațiilor tehnice și economice caracteristice ramurilor industriale analizate;
- Determinarea ponderii elementelor variabile și a efectelor produse de acestea asupra rentabilității/competitivității economice a industriilor analizate;
- Identificarea celor mai oportune și imediate măsuri corective ale efectelor economice determinate de prevederile legislative ale UE precum și a modalităților practice de implementare ale acestora.

### ***Recomandări***

- Necesitatea realizării și implementării unui sistem de evaluare și colectare a datelor (raportarea acestor date ar trebui să fie o obligație din partea agenților economici prevăzută prin lege);
- Cercetarea a fost elaborată pe vechea structura de organizare a sectorului energetic cu companii bazate pe resursa energetică primară (nuclear, hidro, termo);
- Înființarea celor două companii energetice (Electrica, Hidroenergetica) cu structuri mixte de combustibili necesită elaborarea unui nou studiu de optimizare a încărcării centralelor electrice astfel încât costurile de producere ale energiei electrice să fie minime;
- În ceea ce privește managementul portofoliului de certificate, acesta trebuie evaluat corect astfel încât, impactul prețului certificatelor să fie minimizat;
- Se impune ca până în anul 2012 eventualul disponibil de certificate să nu fie "risipit" urmând a fi utilizat strict pentru investiții de reducere a emisiilor;

- Se impun propuneri de modificări legislative privind constituirea de provizioane pentru a putea prelua impactul indus de EU ETS după anul 2013;
- Neaplicarea sau întârzierea în adoptarea măsurilor recomandate poate avea consecințe economice greu de recuperat, putând conduce până la închiderea unității industriale în cauza.