

About the History of Water Supply

Cristian Stăniloiu¹

Constantin Florescu²

Abstract: In the present paper the authors intend to highlight issues related to the history of water supply. Following the research of interesting bibliographic sources, historical data have been selected and presented which refer to the efforts made in antiquity to ensure the need for clean water, vital to human communities. Many of the constructions and installations made at that time are impressive by the technical solutions that have been adopted and their practical implementation. The paper refers to water supply systems in ancient Greece, the Roman Empire and the Byzantine Empire, in ancient Dacia. It also highlights the seriousness with which the antiquity builders have dealt with drinking water supply.

Keywords: antiquity, drinking water, fountains, aqueducts, pipes.

1. GENERAL HISTORICAL DATA

Water is the most important aliment, without water there is no life. For this reason, human collectives have always developed near water sources. This may be rivers (the most commonly encountered situation), lakes, springs or oases. The disappearance of the water source meant the disappearance of the respective human community, and people were forced to look for a new place where they could organize themselves, [2], [3], and [4]. Thus the great antiquity cultures developed in the vicinity of the great rivers, such as Euphrates, Tiger, Nil, Indus and Hoang Ho [1].

To establish a settlement were taken into account the position of the water source, access to the water source, its stability, but also the dangers it represented, such as the destruction caused by periodic floods, the attraction of wild animals and others [3].

With the stabilization of the nomadic peoples and the establishment of permanent settlements, there was also the need to provide water for the various uses and, in particular, drinking water for people and animals that inhabited that locality. Care was also taken that the water used and the excess water, especially the rainfall, would be removed from the settlement [2].

Already in antiquity, the issue of providing water for drinking and other needs as well as the discharge of surplus water has been raised for the organized community, or rather for its leaders, [2]. That is, those works that we call today water supply and sewerage.

If in the antiquity sewage works were usually insufficient to provide hygienic living conditions for

the inhabitants, the water supply work was often distinct, both in scale and ingenuity. Such works impress even today [2].

Interestingly, these works, considered monuments of technique, have been ignored and even destroyed in the Middle Ages and the Modern Age, when hygienic conditions have left much to be desired [2]. Very late, along with evidence of hydric diseases, recourse to rethinking and restoration of the water supply and sewerage works as we know them today.

Because in antiquity did not have the necessary pumps to raise the water level artificially, it was transported to the consumption areas by gravity installations. The water was captured directly from rivers, lakes or springs and from wells or other underground catchments set up for this purpose. Noteworthy, are also the rainwater collection tanks [2].

Here an observation has to be made, the historical sources testify, according to [2], a very ingenious invention attributed to the Greek mathematician and technician Archimedes, 3rd century BC, namely the Archimedes' screw [5]. This is a water lifting system known today as the snail pump. According to [2] it is possible that this system already existed in Mesopotamia, according to cuneiform writings from the reign of King Sanherib, 8th or 7th centuries BC. We can talk here about the first mechanized water lifting system.

If the source of water on or near the town was inadequate, quantitative and qualitative, it was necessary to bring the water away from greater distances. Thus, the problem of water transport, that is, the realization of adductions that bring water from the source to the consumer, has been put forward [1]. Adductions were usually open channels, which tracked the natural slope of the land. Due to the wars, however, closed channels, probably made in secret. Subsequently, the galleries necessary for the penetration of rocky areas and the aqueducts necessary for the crossing of the valleys were followed [2].

The first penetration of a mountain by a tunnel is dated 700 years ago B.C.E. and the proper water transport pipes were made of stone, clay (ceramics) or lead [2]. These pipes, of course, were not pressure pipes. At that time, the steel piping and sealing gaskets were not known. Still, there are mentioned stone pipes discovered in Patara, Greece, which can

^{1,2} Politehnica University Timisoara, Department of Hidrotechnical Engineering, George Enescu Street, no.1A, Zip code 300022, Timisoara, Romania, c_staniloiu@yahoo.com

be considered as the first pipelines for the pressure water supply in the world [2]. These pipes were made of perforated cubes inside, figure 1. The stone cubes were then joined, following the desired path [1].

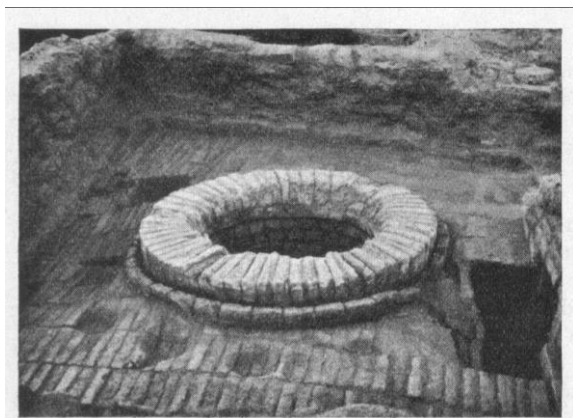

Figure 1. The upper part of a dug well made in wedge shape bricks

All Greeks have also discovered the possibility of crossing the valleys by siphons, thus giving up the aqueducts with gravitational function [2]. The transport system from the Pergamon fortress, through a siphon pipe, operated at a pressure of 20 bar [1], [2].

Later, the Romans also used the siphon effect on water transport, mentioning [2] the Alatri water transport pipeline, which operated at a pressure of 10 bar. Here is the natural question, why did the Romans technicians build expensive aqueducts, if they could instead make bronze pipe siphons? One answer would be that the bronze diameters of large diameters could not be achieved with the technology of that time [2]. Thus water flows through the siphon were much lower than the water flows through the aqueducts [1].

The first water supply systems appeared in parallel with crop irrigation, Egypt, Babylon, Assyria, China and Syria [2]. But people noticed the underground water quality very quickly. It is supposed that the oldest fountains were made by the Sumerians in Mesopotamia with 4000 years B.C.E., [1]. Fountains with this age are also those in Mohenjo-daro from Indus, figure 2 [1].

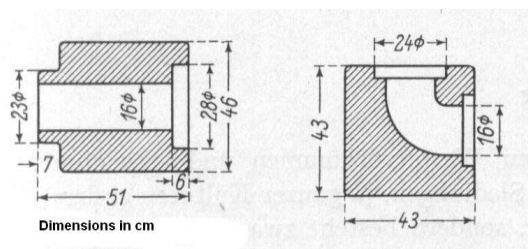

Figure 2. Pipes of stone cubes

Also in Egypt, in addition to water capture and transport operations in the Nile, drinking water supply wells are also representative [2]. General historical data mentions the existence of such wells of great capacity already with 2500 years ago B.C.E. [2]. We can consider that these fountains appeared in antiquity as a necessity to ensure a quality drinking water that is not influenced by the season. Thus, long and vulnerable additions have been eliminated.

Probably the location of the fountains was made taking into account the needs of the populated centre.

In ancient China, these fountains have been a great effort, with very deep wells out of which the water is drawn out by buckets with rope wrapped in a wooden drum [2].

Other deepwater wells were built in Assyria under King Assurnassirpal, 883-859 BC. Under Sennacherib, between 705 and 681 BC, the water network for the city of Nineveh was built. This network consisted of a 45-kilometer-long adduction channel. Part of this channel was made with the chisel in the rock [2].

According to some historical sources, concerning Babylon and Assyria, the hanging gardens of the Babylonian Semiramis queen, 766 BC, were paved with lead plates and irrigation water was taken from the Euphrates River and raised by a buckets system to the height 92m [2]. Thus, through simple, manually operated or animal-operated systems, water was lifted to appreciable heights. This was yet another step in the development of a complex water supply system.

A surprising variety in Syria's water supply is provided by the fountains and springs, Ras-el-Ain, for water supply to Tyrus. It is supposed that the oldest were made by Fenicieni, ca. 700 BC, during the five-year siege of the city of Tyrus [2].

Carthage also had a water supply, which was later restored under Emperor Hadrianus, 123 BC [2].

Punic colony of Motye (Sicily) benefited from the spring water in the mountainous area. The water was channelled through a network that was partly made of zinc pipes [2].

Famous wells are also in Judea. One of the fountains, called Jacob's fountain near the village of Sicheim, would have had a depth of 23 m [2].

The water supply of ancient Jerusalem, carried out between 1015 and 975 BC, was performed from the "Solomon Lakes", between Bethlehem and Hebron [2]. It is assumed that these works were made under the influence of the Phoenicians, [2]. The city was supplied with five water supplies, two of which have been preserved to this day, that of Lake Mamilla and the Siloah Spring. The Siloah adduction is accomplished through a tunnel [2]. This tunnel, with a length of 537m, was made starting from the excavations on both sides, at the junction the differences being minimal [1].

From the springs of Solomon they have been preserved until now three. They are in the form of stepped tanks in which the water from the neighbouring springs was collected [2].

A remarkable achievement is the water supply of Damascus. The water was sampled from the Barada River and directed through a distribution network to the impressive gardens and to the houses of the great city [2]. Another ancient Syrian city that has benefited from a canal water supply is Aleppo. Here are also mentioned the waterwheels for lifting the water [2]. Large capacity open water pools were discovered among the ruins of Palmyra. These pools were located near the temples, and it is assumed that the stored water was used for religious rituals [2]. In

the city of Hamah, water from the river was raised with wheels that were 25m in diameter [2].

2. ELOQUENT EXAMPLES OF ANTIQUITY

2.1. WATER SUPPLY IN ANCIENT GREECE

Already in antiquity the Greeks have understood the importance of water in the development of a culture. Many public fountains have been built as water sources for the population. According to a law passed by Solon, probably 560 BC, they were only allowed to be used by residents living less than 740m. Residents located at a greater distance, other inhabitants had access to these wells only if they could prove to have dug a well, but found no water up to a depth of 17 span arm, about 18m [2].

In addition to these wells, the existing springs were captured. The springs were consolidated and adorned with architectural elements. Subsequently, there were also adductions that channel the spring water to the places of consumption [2]. In the areas where the wells and springs were insufficient, built-up reservoirs were built, which also had the role of storing rainwater [2].

Greece's oldest water pipelines are considered to be those of Mycenae and Argos. From safety, the Greeks have made these underground pipes [2].

Other remarkable works of water supply in ancient Greece are those of Athens, Theben, Magara, Akragas and Samos.

The water supply for the city of Athens consisted of underground canals provided with a lot of maintenance and ventilation manhole. It is supposed that in the glory period, when the city counted about 200,000 inhabitants, there were 18 such adductions. Modern Athens still uses one of them, (rebuilt) [2].

Herodotus described the water supply of the city of Samos in the 6th century BC. The water collected from the Leucothea spring was transported to the city at a distance of 1100 m. For this purpose, an underground gallery was built in which ceramic pipes were installed. Subsequently, through a network of ceramic pipelines, water was distributed in the city, [2]. The work was done by Eupalinos of Megara. Ceramic pipes were 600mm long and 180mm in diameter. Piping joints were made through white-sealed plugs. On portions where no pipelines were used, the water flowed through open channels of 170 / 220 mm [2].

Particularly interesting is the water supply of Patara. A portion of the adduction is made by an aqueduct in the siphon. The pipelines in the stone, on the crown of the aqueduct at 9, 60 m, can be considered as Greece's oldest pressure pipelines [2].

Of the many water supplies made by Greeks, in their own towns and colonies, it is also worth mentioning the water supply of Pergamon. This is also a pressure plant [1], [2]. The water was taken from some springs from the Madras Mountains at a height of 1200m and brought through three ceramic low pressure pipelines at 60km in a stone reservoir that also served as a sand separator [1]. The pipes were ceramic, with a length of 480mm, a diameter of

180mm and a thickness of 60-90mm [2]. According to some historians this work was done by King Eumenes II, 197-159 BC, [2]. The connection between the reservoir and the fortress was made through a pressure pipe that traversed a valley with a depth of 195m [1]. The route of adduction was rebuilt, and so it was found that at the points of the lowest water pressure in the pipe were 17-20 atmospheres [1], [2]. The pipeline was fixed in perforated stone blocks placed on plates, figure 3 [1]. However, no vestiges of the pipelines used were found. Thus, material that has withstood such pressure is not known [2]. They are supposed to be made of bronze, copper or lead [1].

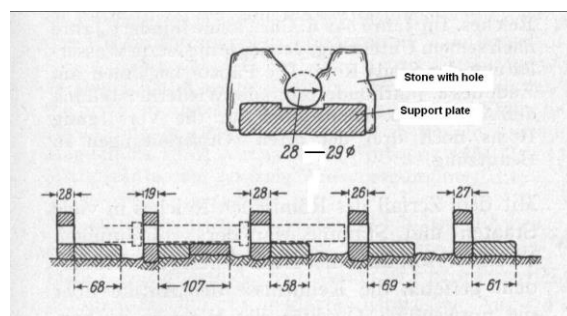

Figure 3. The way of achieving the pipeline

A special case is the Alexandria city water supply. This is due to the water source and the way it is stored. The water was stored in 360 tanks, including some underground, two, three or four levels. The water was taken from the Nile via the Alexandria Canal, from where the water came through the underground galleries in the reservoirs. The supply of the tanks was controlled, with the possibility of closing the galleries [2].

2.2. THE ROMAN EMPIRE

The water supply of the Romans had the most extensive development during the antiquity. Characteristic of this works are water additions. They did not follow the relief of the terrain, but they ensured a steep slope, through the mountains and through deep valleys. Some of these impressive constructions have been preserved to this day [2].

The Roman additions were usually masonry channels, galleries, lead or ceramic pipes, and in some cases perforated tuff stone. As far as possible, open channels have been avoided. In his architectural works, Vitruvius (Marcus Vitruvius Pollio, architect and Roman engineer, 1st century BC) mentions the thickness of the material from which the water transport pipes are made and how to make the watertight joints [2].

Thus Vitruvius recommends a casting length of 3m lead plates. Lead plates were then bent to form a pipe. The bending was done after an oval profile with the tip up. The sealing was done with mastic, by gluing or by incorporating the pipe into the masonry. If soldering was used, this was also done with lead [2]. The pipes between them were also glued or joined through the sockets, Figure 4[1], [2].

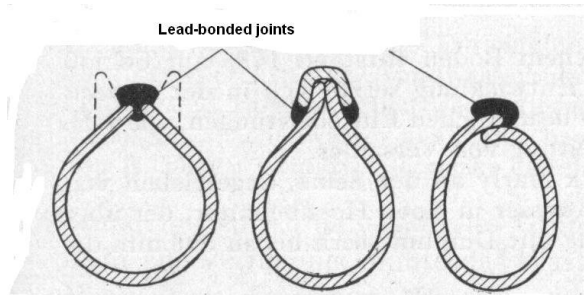

Figure 4. Cross section of Roman lead pipes

The adduction pipes of ceramic had a wall thickness of at least 2 inch (50 mm). The joints of the pipes were made through penetration with conical heads. The sealing was achieved by filling the joint area with a mixture of quicklime and oil [2].

The distribution pipes were made of lead or ceramic, Vitruvius preferring ceramic because he realized the toxicity of lead [2]. In spite of this, in ancient Rome, the most common pipelines were still made of lead [2].

Another personality that was imposed in Ancient Rome is Frontinus, 40 - 103 C.E. From his work results the empirical character of the Hydraulics of that time. For example, it was not known how to determine the flow rate of water. Frontinus refers to the volume of water transported. He made, even empirically, the connection between the volume of water transported, the slope, the diameter and the length of the adduction (the difference between long pipes and short pipes) [2].

The delivery of water to private buildings was done through a system that kept a constant flow, thus quantifying and charging the amount of water delivered. It is assumed that this system was also created by Vitruvius, [2]. The water unit was called "Quinarius". A Quinarius was the amount of water leaked in a given time through a vertical pipe of 300mm in length and 30mm in diameter, in the condition that the water mirror (in the tank) was 330mm above the pipe's upper opening [2].

According to Frontinus, ancient Rome was supplied by nine water additions, Aqua Appia Claudia (311 BC), Anio Vetus (271 BC), Marcia (145 BC), Tepula (126 BC), Julia (34 BC), Virgo (21 BC), Alsietina (19 BC), Claudia (50 CE) and Anio Novus (53 CE) [2]. The total length of the adductions was 436.5 km, out of which 64km of aqueducts and 2.5km of tunnels [1].

Later, in the sixth century, five more adductions were added. According to Procopius (500-562 CE), these were Aqua Traiana (111CE), Severiana (225 CE), Aqua Antoniniana, Aqua Hadriana and Aqua Aureliana [2]. The first six adductions were made during the Roman Republic, (510-27 BC) and the others later, during the Empire [2].

The oldest aqueduct is considered Aqua Appia, built during the republic. It was begun by Gajus Plautius, 358 BC and completed 311BC under Appius Claudius Crassus. The water was transported both underground and aboveground [2]. The built-in

grooves had a rectangular section with the top right, in the form of a roof or arched. The width was between 0.50 - 1.70m and the height between 1.00 - 2.70m. The largest underground gallery dug in the rock had a width of 1m and a height of 2,30m [2].

The amount of water transported through these adductions may seem enormous for that time. However, account should be taken of the fact that much of the water was lost due to leaks and other inherent technical problems. According to some authors, the amount of water delivered during the glory period of ancient Rome corresponds to 230 liters per inhabitant per day [2].

Obviously, these adductions, especially their overhead, i.e. aqueducts, required extensive maintenance. Historical sources mention the repairs made by Emperor Caracalla (188-217 CE) at the Marcia adduction, [2]. There followed a time when these works were not given due attention. Other repairs are mentioned only in the year 400 CE, carried out under the emperors Arcadius (Byzantine Emperor, 395-408 CE) and Honorius (emperor of the Western Roman Empire, 395-423 CE) and later by king ostrogot Theoderich (493-526 CE) [2].

Due to the increased need for water, the highest aqueducts were used to lift the pressure. This explains the vertical development of existing aqueducts by their multi-layering. Two or three storey aqueducts have thus been reached. An example is the Aqua Claudia aqueduct, 32 m high [2].

Water quality was source-dependent. Thus, some water sources served for drinking water, and others, with lower quality water, for other uses [2]. For the clarification of the water, i.e. sedimentation of the impurities, decanting basins called Piscinae were built. They were also used as fish ponds. These buildings executed and with two floors, were impressive. Their volume was calculated to correspond to the volume of water corresponding to the maximum consumption time [2]. Frontinus has established, according to quality, three water categories. Thus, he mentions drinking water, medium-quality water was destined for the term, and inferior quality water was used in gushing wells and in sewage washing [1].

Castles of water, called castella, were also built. They were made up of three rooms. The middle room, endowed with an overflow pipe, took the water from the adjoining rooms. This ensures a constant level of water in the middle chamber and a constant pressure on the gushing fountains in the city. The side rooms fed the bathrooms and the installations of the private houses [2]. It should be noted that the water connection of a private property could only be done with the consent of the emperor [2].

Apart from the water supply of Rome, should also mention those of the cities Fondi, Pisanus, Pollentia, made in 173 BC and then Napoli and Alatri [2].

Remarkable is the water supply of the city of Alatri, 100 BC, where a siphon of lead pipes with a diameter of 100 mm and a material thickness of 10 - 35 mm was built. This siphon had a pressure of 10 atmospheres [2]. Such siphons were also made in the

Roman colonies, Lyon, Pergamum, Arelatum and Apendus [2]. The Lyon siphon was made of ten lead pipes and showed a 123m level difference, which is a 12 atmospheres pressure. In other works, where water pressure was not so high, the siphon pipes were made of ceramics [2].

In the fourth century CE in Rome there were 11 thermal baths, 926 public baths, 1212 glowing fountains and 247 tanks of height [1]. Throughout the territory of the Roman Empire are known 93 adductions, 42 in northern Africa, 6 in Italy (except Rome), 10 in France, 6 in Germany and Austria, 13 in Asia Minor and Syria, and 4 in Spain [1].

Among the aqueducts built in colonies the most imposing is the one from Galia, Ponce du Gard, for water supply to Nemausus. This aqueduct is a bridge-type construction, with three levels, made of 256 arches. The largest have a 24m opening. The construction crosses the Garonne Valley and has a length of 2000m and a maximum height of 45m above the river water [2].

The largest Roman building that has been preserved in Spain today is the Segovia aqueduct, built under Trajan. The construction has a length of 818m, is made of 109 arches, superimposed on two floors [2].

2.3. THE BYZANTINE EMPIRE

Most of the hydro-sanitation works of the Roman Empire cannot be attributed to antiquity but to the Middle Ages. However, some remarkable works are known to us. We remind the Valens aqueduct, located in Istanbul today, the European side. The construction was begun by Constantine the Great, (306-337) and completed by Emperor Valens in 378. The aqueduct is made in two-storey arches, its height being 23m. Original length was 1200m, still preserved 800m.

3. CONCLUSIONS

From the above it shows the importance of water both for drinking and sanitary hygiene, which has been recognized since ancient times. At the location of the large populated centres of antiquity, it has always been taken into account the existence of a stable source of water to provide quality water in the required quantity.

With the formation of city-fortress townships, water sources and access to them became of strategic importance.

Achieving the water supply included all the elements as we know it today, the water source, the water supply, water pumping, water treatment, water storage and distribution. These works were regarded as a whole.

Achieving the necessary constructions and facilities was a priority, investing large volumes of materials and using the most durable materials for that era. Lead, even if widely used, has been recognized as a toxic material. It has been pursuing stable and reliable constructions. Vertical and horizontal digging techniques have been applied even in heavy or rocky terrain.

Even though the hydraulic knowledge of the era was empirical, the optimal solutions to water transport solutions have always been found. Impressive long length and high-capacity transport networks, large storage tanks and water lifting systems or constant-level water castles.

It is worth noting and establishing the water quality categories and introducing priorities in its use according to quality. The water was not used exclusively for drinking, were achieved public baths, gushing wells, channels for sanitation of the village, irrigation of gardens. Mechanical water treatment systems have also been created, recognizing the superior quality of water from underground sources, or, for certain uses, rainwater has been captured and stored.

Last but not least, we can talk about a water economy by laying down laws and rules on water distribution and consumption and imposing fees for the beneficiaries.

REFERENCES

- [1] Brix Joseph, Heyd Hermann, Gerlach Ernst, 1963, „Die Wasserversorgung“, R. Oldenbourg, München, Wien;
- [2] Friedrich Adolf, 1914, „Kulturtechnischer Wasserbau“, zweiter Band, Verlag für Landwirtschaft, Gartenbau und Forstwesen, Berlin;
- [3] M, Giurconiu și colectivul, 2002, „Construcții și instalații hidroedilitare“, Editura de Vest, Timișoara;
- [4] Kainz Harald, Kauch Ernst Peter, Renner Helmut, 2002, „Siedlungswasserbau und Abfallwirtschaft“ Manz Verlag Schulbuch, Wien;
- [5] <https://de.wikipedia.org>
(https://de.wikipedia.org/wiki/Archimedische_Schraube)